



Operating Manual



FOX-2001D FOX-2001T FOX-2001F

1 Safety

※ Pls use this item after installing the duplex safety device in which is applied at dangerous factors such as serious human injury or serious damages of property & important machine because this item is not designed as safety device

WARNING

- As the product is not manufactured as safety equipment, make sure to use this product after mounting double safety device when using it for the purpose of controlling a device having risk of personal injury, equipment damage or huge property loss.
- Do not cut the wire or make check-up or maintenance when the power supply is connected.
- Make sure to check the socket number before connecting the power.
- Never disassemble process, improve or repair this equipment.

CAUTION

- Please carefully read and digest the operation procedure and safety related regulations or WARNING descriptions prior to the use of product, and make sure to operate the product only per the relevant specification or within the corresponding capacity rating.
- Do not make wiring or install the product on motor or solenoid with large inductive loads. When extending the sensor, use the shielded wire not extending the extension wire length unnecessarily long.
- Do not use the components generating arc when opening and closing under same power supply line or near to power supply.
- Keep the power supply line away from high voltage wire, and avoid installation at the locations subject to severe moisture, oily content and dust.
- Do not install the product at places exposed to direct sun light or rain.
- Do not install the product at places subject to strong magnetism or severe noise, vibration and impact.
- Keep the product far away from the places directly producing strong alkali or acidic substances using separate conduit for wiring.
- Do not spray water on the product for cleaning purpose when installed at kitchen area.
- Do not install at those places under the temperature and/or moisture exceeding the rated capacity.
- Use the product paying attention not to have disconnected sensor wiring or defect.
- Allow the sensor wiring stay away from signal, power supply, drive and load wires using separate conduit for wiring.
- Please note that no warranty services shall be provided when the product is disassembled or modified at user's own discretion.
- The mark shown on Terminal Wiring Diagram is a safety notice notifying warning or caution.
- Do not use the product at places near to the devices generating strong high frequency noise (High frequency welding machine, high frequency sawing machine, high frequency radio, large capacity SCR controller).
- Using the product with procedures not specified by the manufacture may incur the personal injury or property damage.
- Not being a toy, do not allow children touch the product.
- Make sure to execute the installation only by the skilled person with related industry or authorized personnel.
- CONOTEC shall assume absolutely no responsibility of whatsoever nature for those damages and/or losses incurred due to the operation not complying with above WARNING or NOTE descriptions or negligence and/or fault of user.

Danger

- Caution, Danger of electric shock
- Electric shock - Do not touch AC board during on power because of electric shock.
- Please intercept input power surely when input power check.

2 Composition

Model	Sensor	Output	Temp.range	Function
FOX-2001D	NTC	relay (2EA)	-55.0℃ ~ +99.9℃	Temp.
FOX-2001T	NTC	relay (3EA)	-55.0℃ ~ +99.9℃	Temp.
FOX-2001F	NTC	relay (4EA)	-55.0℃ ~ +99.9℃	Temp.

3 Part name



- OUT1 output lamp
- OUT2 output lamp
- OUT3 output lamp
- OUT4 output lamp
- Setting up
- A Key for function's change
- Setting down

The function of each key

- : A key to change of the programs & setting temperature
- : A key to change of the temperature or the program's set values.

4 Dimension

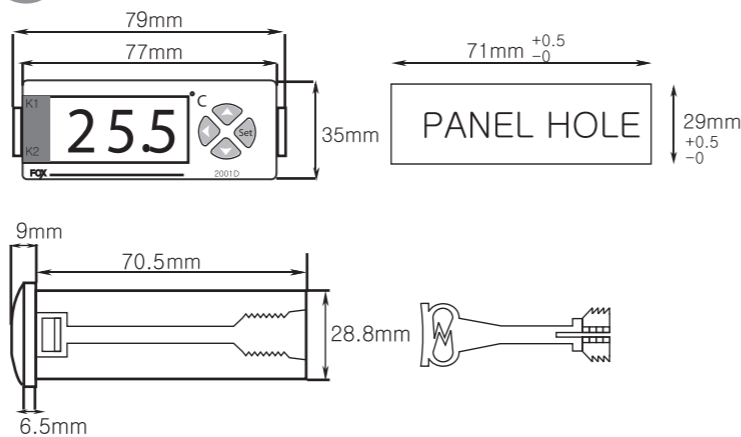

Relay junction

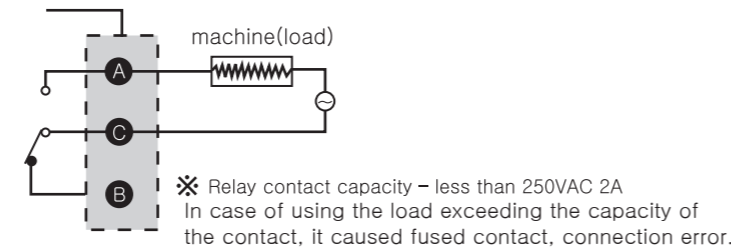

5 Connection

Connection

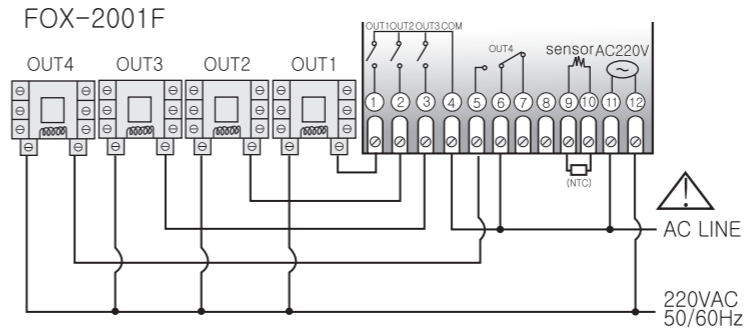
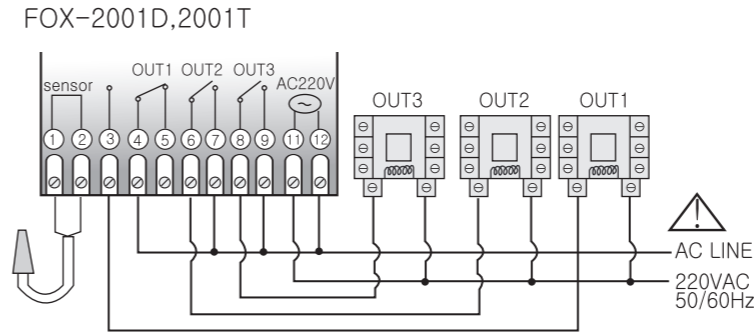

6 Temp range&set value when deliver

	Function	Display	Range	Set value when deliver	Remark
Setting temp.	Setting temp. 1	St 1	-55.0 ~ 99.9	10.0	
	Setting temp. 2	St 2	-55.0 ~ 99.9	10.0	
	Setting temp. 3	St 3	-55.0 ~ 99.9	10.0	
	Setting temp. 4	St 4	-55.0 ~ 99.9	10.0	
Program setting	Setting for the highest limit of use	HSP	LSP ~ 99.9	99.9	It is irrelevant to the relay output
	Setting for the lowest limit of use	LSP	-55.0 ~ HSP	-55.0	It is irrelevant to the relay output
	Correction of temperature	Cor	-5.0 ~ 5.0	0.0	Correct for discrepancy between the display and real temp.
	Lock function	LoC	on / off	off	on: LOCK off: Unlock however, except for the set value.
	Temp. 1 function select	TP 1	C / H	C	C : cooling H : heating
	Delay time set for temp.1 output	dt 1	0.00 ~ 9.99	0.00	
	Temp. deviation for temp. 1	df 1	0.1 ~ 19.9	1.0	Hysteresis +
	Temp. 2 function select	TP 2	C / H	C	Refer to remark on the temp. 1 function select
	Delay time set for temp.2 output	dt 2	0.00 ~ 9.99	0.00	
	Temp. deviation for temp. 2	df 2	0.1 ~ 19.9	1.0	Refer to the remark Temp. 1 deviation temp. setting
Temp. 3 function select	TP 3	C / H	C	Refer to remark on the temp. 1 function select	
Delay time set for temp.3 output	dt 3	0.00 ~ 9.99	0.00		
Temp.3 deviation temp. setting	df 3	0.1 ~ 19.9	1.0	Refer to the remark Temp. 1 deviation temp. setting	
Temp. 4 function select	TP 4	C / H	C	Refer to remark on the temp. 1 function select	
Delay time set for temp.4 output	dt 4	0.00 ~ 9.99	0.00		
Temp.4 deviation temp. setting	df 4	0.1 ~ 19.9	1.0	Refer to the remark Temp. 1 deviation temp. setting	

7 Setting value change sequence

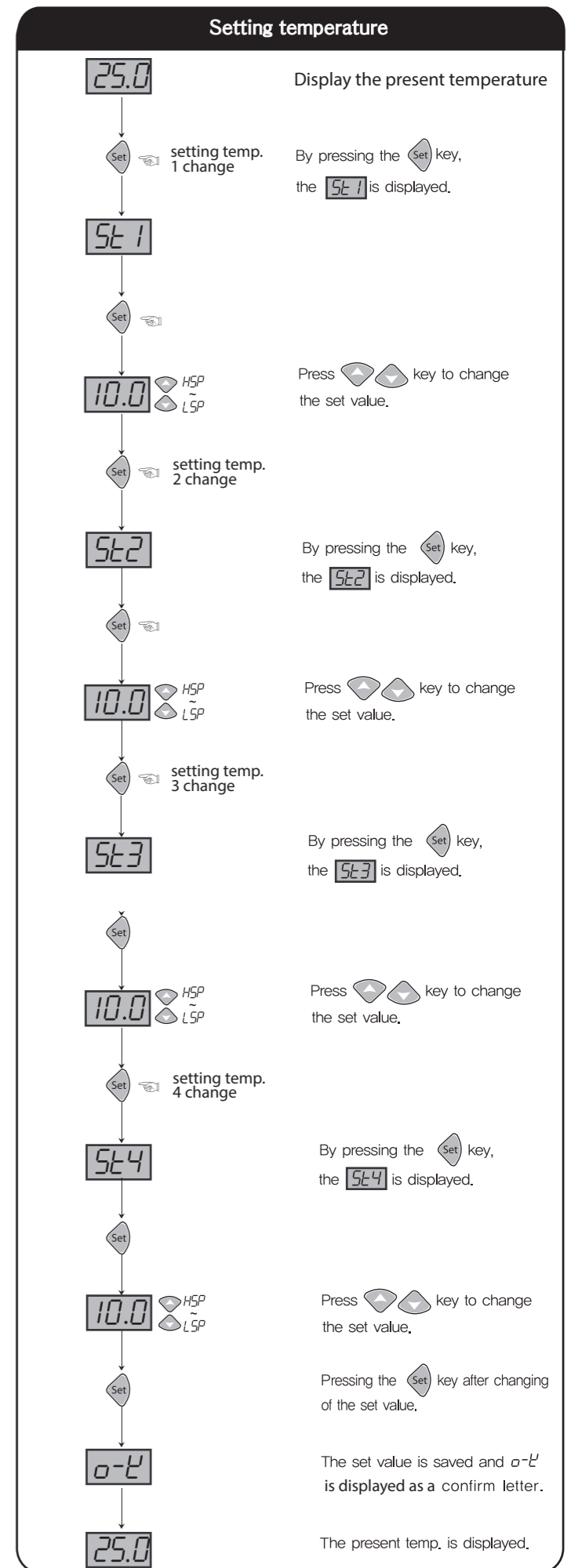

Setting for programs

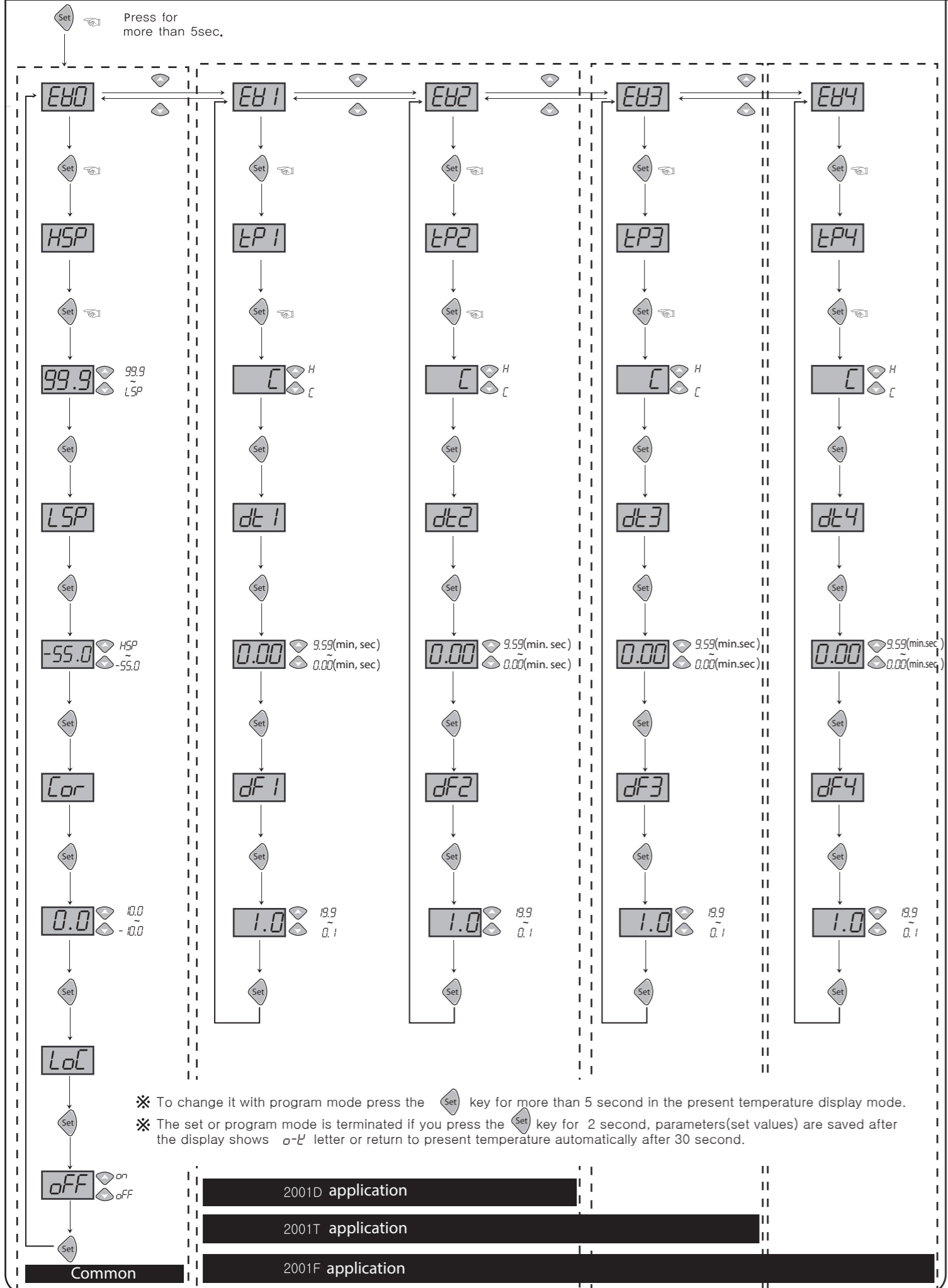

※ To change it with program mode press the **Set** key for more than 5 second in the present temperature display mode.
 ※ The set or program mode is terminated if you press the **Set** key for 2 second, parameters(set values) are saved after the display shows **o-E** letter or return to present temperature automatically after 30 second.

8 Detailed manual

- St1** : setting for the 1-stage temperature(application model : 2001D, 2001T, 2001F)
- St2** : setting for the 2-stage temperature(application model : 2001D, 2001T, 2001F)
- St3** : setting for the 3-stage temperature(application model : 2001T, 2001F)
- St4** : setting for the 4-stage temperature(application model : 2001F)
- HSP** : Setting function of the highest limit of temperature range (maximum set point allowed to the end user)
 - Impossible to set up the set value more than HSP set value
 ex) HSP = 25.0°C setting ⇒ impossible to raise the set value more than 25.0°C
- LSP** : Setting function of the lowest limit of temperature range (Minimum set point allowed to the end user)
 - Impossible to set up the set value less than HSP set value
 ex) HSP = 10.0°C setting ⇒ impossible to lower the set value less than 10.0°C
- Cor** : Correction of the present temperature.
 The product itself has no problem, but the correction function for that if temp. differs between an error occurs in the input the sensor from outside and basic temp. (ex. mercury thermometer or an existed using thermometer, temperature controller)
 ex) real temp. : 25.0°C If discrepancy 3°C between the real temperature and the displayed
 display : 28.0°C
 Cor : 0.0 → if corrected to -3.0 will be displayed 25.0°C
- Lof** : The lock function
 - As a safety device, it is used in order not to change the set values except for the main user.
 ON - All setting values for the lock function except for the set value.
 OFF -All setting values for the unlock function except for the set value.
- LP1** : Selection of the Temp. 1 or or Cooling(C) or Heating(H) (application model : 2001D, 2001T, 2001F)
- dt1** : Temp. 1 output delay time(application models : 2001D, 2001T, 2001F)
 In case of operating ON/OFF control very often, (Cooler, compressor and so on) to protect the operation machi nery when re-input of the power supply or momentary stoppage of power supply.

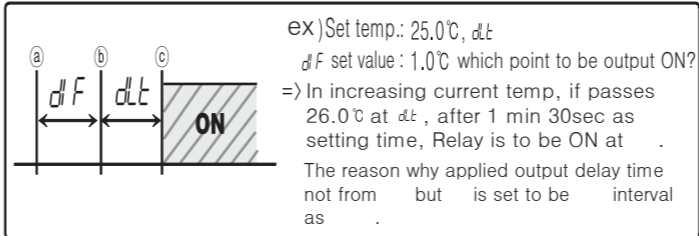

- df1** : Setting deviation for temperature 1 (application models : 2001D,2001T, 2001F)
 - In the ON/OFF control it needs at regular interval between ON and OFF. By operating the ON/OFF control frequently, the relay or its output contact can be damaged quickly and it also occurs the hunting (oscillation, chattering) by virtue of external noise. You can make use of the temperature deviation in order to protect its relay or contact and so on.

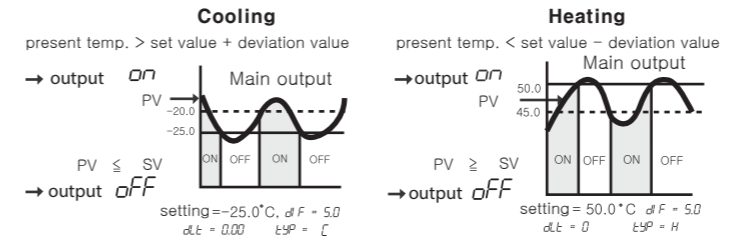

- LP2** : Selection of the Temperature 2 cooling(C) or heating(H)
 See the No. 9(application models : 2001D,2001T, 2001F)
- dt2** : Delay time of the temperature 2 output
 See the No. 10(application models : 2001D, 2001T, 2001F)
- df2** : Setting deviation for temperature 2
 See the No. 11(application models : 2001D, 2001T, 2001F)
- LP3** : Selection of the Temperature 3 cooling(C) or heating(H)
 See the No. 9(application models : 2001T, 2001F)
- dt3** : Delay time of the temperature 3 output
 See the No. 10(application models : 2001T, 2001F)
- df3** : Setting deviation for temperature 3
 See the No. 11(application models : 2001T, 2001F)
- LP4** : Selection of the Temperature 4 cooling(C) or heating(H)
 See the No. 9(application models : 2001F)
- dt4** : Delay time of the temperature 4 output
 See the No. 10(application models : 2001F)
- df4** : Setting deviation for temperature 4
 See the No. 11(application models : 2001F)

Output specifications

Sensor	2001 (1EA)	2001D (1EA)	2001T (1EA)	2001F (1EA)	2000TT (1EA)		
Temp.	1 stage	2 stage	3 stage	4 stage	control by temperature & time (for greenhouse)		
Sensor	2001 1EA	2002 1EA	2002DN wide use	2003 2003S 1EA	2004 2EA	2005 2EA	2006 2EA
Temp.	○	○	○	○	○	○	Temp.1 ○ Temp.2 ○
Alarm	-	○	○	-	-	○	Alarm1 ○ Alarm2 ○
Defrost	-	-	-	○	○	○	-
FAN	-	-	-	○	○	○	-

Application

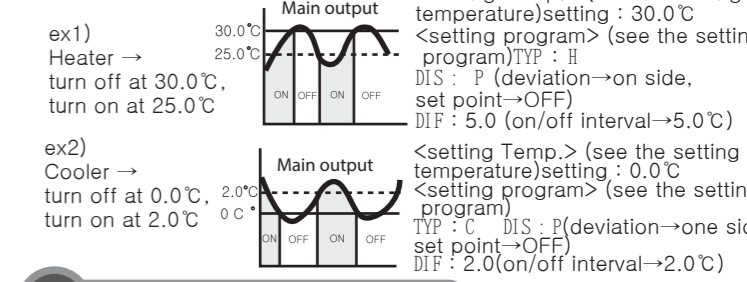

9 How to diagnose a breakdown

- ### Indicating ERROR on using items
- This **Erl** is the damage of memory data for various of inner-DATA due to be got nosied strongly from outside while using this items. Please request us A/S by return.
 - Although our controller is designed as the complementary measures regarding these noise from outside, it is not endurable against these noise with endlessly.
 - If noise(2KV) disordering become an inflow, the inner-part will be damaged.
 - If these letters like **o-E** (open error) and **S-E** (short error) indicates, the sensor's error is the main cause of the displaying. Please check the sensor
- ※ The products specification can be changed without any notification to improve its quality
 When using this product, please observe the information of warning due to give rise to disordering.
- ※ Regarding the English-language manual, please download it at our homepage.

H. Office: CONOTEC B/D 2nd floor, 26, Yunsan-ro, Geumjeong-gu, Busan, 609-821 Rep. of KOREA
Factory : CONOTEC B/D B1, 26, Yunsan-ro, Geumjeong-gu, Busan, 609-821 Rep. of KOREA

A/S TEL : 070-7815-8266
 TEL : 051-819-0425 ~ 7
 URL : www.conotec.co.kr
 e-mail : conotec@conotec.co.kr

Main products & Development

- Digital temperature controller
- Digital humidity controller
- Digital timer