

Graphic Panel

GP-S044/S057

USER MANUAL



Preface

Thank you very much for selecting Autonics products.





Please familiarize yourself with the information contained in the **Safety Considerations** section before using this product.

This user manual contains information about the product and its proper use, and should be kept in a place where it will be easy to access.

User Manual Guide

- Please familiarize yourself with the information in this manual before using the product.
- This manual provides detailed information on the product's features. It does not offer any guarantee concerning matters beyond the scope of this manual.
- This manual may not be edited or reproduced in either part or whole without permission.
- A user manual is not provided as part of the product package. Please visit our home-page (www.autonics.com) to download a copy.
- The manual's content may vary depending on changes to the product's software and other unforeseen developments within Autonics, and is subject to change without prior notice. Upgrade notice is provided through our homepage.
- We contrived to describe this manual more easily and correctly. However, if there are any corrections or questions, please notify us these on our homepage.

User Manual Symbols

Symbol	Description
 Note	Supplementary information for a particular feature.
 Warning	Failure to follow instructions can result in serious injury or death.
 Caution	Failure to follow instructions can lead to a minor injury or product damage.
 Ex.	An example of the concerned feature's use.
※1	Annotation mark.

Safety Considerations

- Following these safety considerations will ensure the safe and proper use of the product and help prevent accidents and minimize hazards.
- Safety considerations are categorized as Warnings and Cautions, as defined below:

 Warning	Warning	Cases that may cause serious injury or fatal accident if instructions are not followed.
--	----------------	---

 Caution	Caution	Cases that may cause minor injury or product damage if instructions are not followed.
--	----------------	---

Warning

- Fail-safe device must be installed when using the unit with machinery that may cause serious injury or substantial economic loss. (e.g. nuclear power control, medical equipment, ships, vehicles, railways, aircraft, combustion apparatus, safety equipment, crime/disaster prevention devices, etc.)
Failure to follow this instruction may result in fire, personal injury, or economic loss.
- Use the unit within the rated specifications.
Failure to follow this instruction may result in shortening the life cycle of the product or fire.
- Do not connect, repair, or inspect the unit while connected to a power source.
Failure to follow this instruction may result in fire.
- Check 'Power Wiring' and 'Serial Interface' before wiring.
Failure to follow this instruction may result in fire.
- In preparation for product damage, communication error, or malfunction, install external limit switch, emergency stop switch, or other protection circuit.
Failure to follow this instruction may result in fire, personal injury, or economic loss.
- Since Lithium battery is embedded in the product, do not disassemble or burn the unit.
Failure to follow this instruction may result in fire.
- Do not disassemble or modify the unit.
Failure to follow this instruction may result in fire.
- Please contact to us for battery replacement.

**Caution**

- Do not use the unit in the place where flammable/explosive/corrosive gas, humidity, direct sunlight, radiant heat, vibration, impact, or salinity may be present.
Failure to follow this instruction may result in fire or explosion.
- Use dry cloth to clean the unit, and do not use water or organic solvent.
Failure to follow this instruction may result in electric shock or fire.
- When connecting the power input, use AWG 23 cable or over and tighten the terminal screw with a tightening torque of 0.5 to 0.8N.m.
Failure to follow this instruction may result in fire or malfunction due to contact failure.
- Keep metal chip, dust, and wire residue from flowing into the unit.
Failure to follow this instruction may result in fire or product damage.
- Do not push over 2 point at the same time.
Failure to follow this instruction may result in malfunction.

The above specifications are subject to change and some models may be discontinued without notice.

Be sure to follow cautions written in the instruction manual, user manual and the technical descriptions (catalog, homepage).

Cautions during Use

- Follow instructions in 'Cautions during Use'. Otherwise, it may cause unexpected accidents.
- 24VDC power supply should be insulated and limited voltage/current or Class 2, SELV power supply device.
- Install a power switch or circuit breaker in the easily accessible place for supplying or disconnecting the power.
- Operate the product after supplying power to the product, input/output equipment, and load. If operate product before supplying power, it may result in output error or malfunction.
- Keep away from high voltage lines or power lines to prevent inductive noise. Do not use near the equipment which generates strong magnetic force or high frequency noise.
- Make a required space around the unit for radiation of heat, and do not block ventilation openings.
- Do not push the touch panel with a hard and sharp object or push the panel with excessive force. It may result in fire or malfunction.
When skin is smeared with liquid crystal from the broken LCD, rinse with running water for over 15 minutes.
If it gets into the eyes, rinse eyes with running water for over 15 minutes and contact a doctor.
- This unit may be used in the following environments.
 - ① Indoors (in the environment condition rated in 'Specifications')
 - ② Altitude max. 2,000m
 - ③ Pollution degree 2
 - ④ Installation category II

Table of Contents

	Preface	iii
	User Manual Guide	iv
	User Manual Symbols	v
	Safety Considerations	vi
	Cautions during Use.....	viii
	Table of Contents	ix
1	Overview	13
	1.1 Graphic Panel	13
	1.2 Feature of GP	14
	1.3 Model	15
	1.4 Specification.....	15
	1.4.1 General specification.....	15
	1.4.2 Performance specification.....	16
	1.4.3 GP-S044, GP-057 system setting.....	17
	1.5 Communication.....	18
	1.5.1 Communication interface	20
	1.6 Unit description	21
	1.6.1 GP-S044.....	21
	1.6.2 GP-S057.....	21
	1.7 Dimensions	22
	1.7.1 GP-S044.....	22
	1.7.2 GP-S057.....	23
2	Installation	25
	2.1 GP installation.....	25
	2.2 Power wiring	26
	2.2.1 Ground wiring.....	27
	2.3 Battery replacement.....	27
3	Device Construction	29
	3.1 Device element	29
	3.2 Device range.....	29
	3.2.1 Bit device range	29
	3.2.2 Word device range	29
4	System Organization	31
	4.1 Connection with controller	31
	4.1.1 1:1 organization.....	31
	4.1.2 1:N organization	32
	4.1.3 Heterogeneous organization.....	33
	4.2 Universal organization	33
	4.3 Connect with barcode, printer.....	34

4.4	Connect with GP Editor	35
4.4.1	GP Editor configuration	38
5	Start up GP.....	39
5.1	Checking list before supplying power.....	39
5.2	Operation order.....	40
6	System Screen	41
6.1	Organization of system screen.....	41
6.2	Operation of system screen.....	42
6.3	Device monitor.....	43
6.4	Set Environment	44
6.4.1	Language	44
6.4.2	PLC setting.....	45
6.4.3	Clock.....	49
6.4.4	Clear USER DATA.....	50
6.4.5	Menu call key	51
6.4.6	Buzzer	52
6.4.7	Opening time	53
6.4.8	Backlight.....	54
6.4.9	Battery	55
6.4.10	Contrast.....	56
6.4.11	Latch device	56
6.5	Data View.....	57
6.5.1	Base screen	57
6.5.2	Window screen.....	58
6.5.3	Comment.....	58
6.5.4	Memory size	59
6.5.5	Model & Version	59
6.6	Set Function.....	60
6.6.1	Data transfer.....	60
6.6.2	Time switch	62
6.6.3	Print out	64
7	User Screen	65
7.1	Screen specification.....	65
7.2	Screen display object	66
7.3	Screen switching.....	67
7.4	Overlap window function	68
7.5	Device connection status display	70
8	System Window	71
8.1	Key pad type.....	71
8.2	Key pad organization	72
9	Troubleshooting	73
9.1	Error and troubleshooting.....	73
10	Firmware update.....	75
11	Repair and Check	77

11.1	Change repair component	77
11.1.1	Battery replacement	77
11.2	Check	78
11.2.1	General check	78
11.2.2	Periodic check	78

1 Overview

1.1 Graphic Panel

Graphic Panel (after referred to as GP) is graphic interface device for monitoring parameters of controller such as PLC. It is one of human-machine interface (HMI) or man-machine interface (MMI).

If controller does not have visual interface, it is difficult to find out current value or status of process. In this case, GP is a practical device.

GP monitors control parameter visually by LCD screen or switches the other screen or designates variable value by touching touch screen. GP and controller are connected by serial communication and inter-change mutual information.

The variable for controller is displayed by various methods as tag which is graphic object. For example, if the physical variable for monitoring is temperature, GP displays temperature as numeral by numeral input tag, or as trend graph with changes by time. GP screen consists of these graphic objects combinations.

GP Editor which is dedicated software for user defined screen data in GP helps draw screen or edit data. After editing screen data such as tag form, arrangement, and attribution, download these to GP and GP starts to monitor by screen data.

1.2 Feature of GP

- **Product upgrade by web site**
We offer GP firmware, GP Editor, protocol, language and font, various manuals at www.autonics.com to download conveniently.
- **Communication between heterogeneous controllers**
You can connect other type controller to serial port separately.
GP monitors two different controllers simultaneously and relays communication between two controllers.
- **Multi monitoring function**
You can connect same type of several controllers.
- **Supports multilingual**
GP supports Korean, English and the other languages are available for the later.
- **Supports several font**
GP supports various bitmap font and vector font. You can select the desired font and use it.
- **Multi communication port**
GP supports several communication port such as RS232C / RS422 serial communication port, USB HOST USB DEVICE, and Ethernet.
Two serial ports of RS232C / RS422 are designated for the device connecting by software (PLC, computer, printer, barcode reader, etc). By supported communication type of connected device, select port to communication.
- **Monitoring function for controller device**
Without designed data, GP menu is available for monitoring connectable controller device.
- **Print and barcode reader connection**
You can print alarm list by connecting printer.
It is able to read barcode by connecting barcode reader.
- **Touch interface**
It is able to input value in controller with touch switch on front screen.
- **Slim size**
It is easy to utilize space with slim size.
- **Various display function**
It is able to display data with various tags.

1.3 Model

Model	Screen size	Display unit	Color	Power supply	Interface
GP-S044-S1D0	4.4inch	STN LCD	MONO (Blue, White)	24VDC	Each one of RS232C, RS422C
GP-S044-S1D1					Two of RS232C
GP-S057-S1D0	5.7inch				Each one of RS232C, RS422C
GP-S057-S1D1					Two of RS232C

1.4 Specification

1.4.1 General specification

Model		GP-S044	GP-S057
Power supply		24VDC==	
Allowable voltage range		90 to 110% of power supply	
Power consumption		Max. 3.6W (Max)	
Serial interface		GP-S0□□-S1D0: Each one of RS232C, RS422C(Asynchronous method) GP-S0□□-S1D1: Two of RS232C(Asynchronous method)	
Noise immunity		The square wave noise (Pulse width 1 μs) by the noise simulator with ±0.5kV	
Withstanding voltage		500VAC(50/60Hz) for a minute	
Insulated resistance		Min. 100MΩ (at 500VDC megger)	
Ground		3rd grounding(Max. 100Ω)	
Vibration	Mechanical	0.75mm amplitude at frequency of 10 to 55Hz (for a minute) in each of X, Y, Z directions for an hour	
	Malfunction	0.5mm amplitude at frequency of 10 to 55Hz (for a minute) in each of X, Y, Z directions for 10 minutes	
Environment	Temperature	0 to 50°C, Storage: -20 to 60°C	
	Humidity	35 to 85% RH, Storage: 35 to 85% RH	
Protection		IP65 (front panel, IEC standard)	
Accessory		Fixing bracket: 4pcs, Rubber waterproof ring, Battery(included)	
Approval		CE 	
Unit weight*1		Approx. 413g (Approx. 284g)	Approx. 555g (Approx. 376g)

*1 : The weight in parenthesis is only unit weight.

*Environment resistance is rated at no freezing or condensation.

1.4.2 Performance specification

Display performance		
Model	GP-S044	GP-S057
LCD type	4.4inch STN Blue Negative	5.5inch STN Blue Negative
Resolution	240 X 80 dot	320 X 240 dot
Display area	112.8 X 37.6mm	119 X 91mm
Color	Mono(Blue, White)	
LCD view angle	Within each 30° of top/bottom/right/left	
Backlight	White LED	
Brightness	Adjustable by software	
Graphic drawing performance		
Language ^{※1}	Korean, English, Japanese, Chinese, Russian, Vietnamese, Portuguese	
Text	<ul style="list-style-type: none"> ▪ High resolution display up to 400 characters (Based on 6 X 8 font) ▪ 6 X 8, 8 X8 ASCII character, High quality view of numbers (width 1 to 8 times, height 0.5 to 5 times) ▪ 8 X 16 ASCII character, 16 X 16 regional characters (width 1 to 8 times, height 0.5 to 5 times) 	<ul style="list-style-type: none"> ▪ High resolution display up to 1590 characters (Based on 6 X 8) ▪ 6 X 8, 8 X8 ASCII character, High quality view of numbers (width 1 to 8 times, height 0.5 to 5 times) ▪ 8 X 16 ASCII character, 16 X 16 regional characters (width 1 to 8 times, 0.5 to 5 times)
Graphic drawing memory	512kB	
Number of user screen	500 pages	
Touch switch	width15 X height4 = total 60	width16 x height 12 = total 192

※1: You can add other supported languages.

1.4.3 GP-S044, GP-057 system setting

Function		Description
MONITORING	DEVICE MONITOR	Monitors connected PLC device and changes the status
SET ENVIRONMENT	LANGUAGE	Designates system language and character set
	PLC SETTING	Configures serial port for connecting between Editor and connected device, printer, barcode reader, or monitor
	CLOCK	Designates current time and date
	CLEAR USER DATA	Deletes user data downloaded in GP
	MENU CALL KEY	Designates the position for calling system setting menu
	BUZZER	Designates using buzzer or not
	OPENING	Set time for open screen when supplying power
	BACKLIGHT	Set off time for backlight as screensaver
	BATTERY	Displays battery remaining with percentage (%) and bar graph
	CONTRAST	Adjusts LCD screen contrast
DATA VIEW	LATCH DEVICE	Designates maintaining UW device value by GP battery during power OFF
	BASE SCREEN	Displays user-defined base screen title and number
	WINDOW SCREEN	Displays user-defined window screen title and number
	COMMENT	Displays downloaded comment list in GP
	MEMORY SIZE	Displays total memory capacity and available memory capacity
SET FUNCTION	MODEL & VERSION	Displays current version of GP series and model name.
	DATA TRANSFER	Displays this menu during communicating (download/upload) between GP and GP Editor
	TIME SWITCH	Designates time switch
	PRINT OUT	Prints out alarm history with printer

1.5 Communication

Depending on PLC model type, connections for PLC are different, therefore refer to 'GP, LP user manual for communication'.

Every device such as PLC is able to connect any RS232C or RS422 port.
CH1, CH2 is designates in GP Editor.

(1) Connection of 1 PLC

Connect PLC to a port and one of PC, printer, barcode reader to the other port.

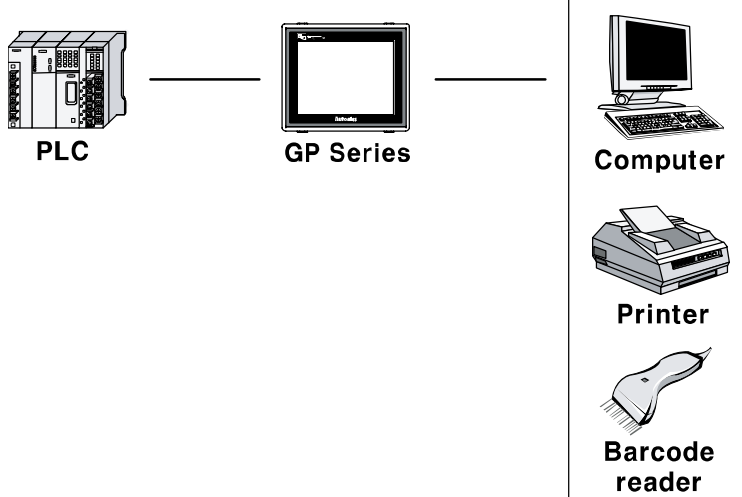

(2) Connection of CH1 and CH2

Connect PLC to GP ports.

It is able to connect even if CH and CH2 are not same type PLC, GP can relay data exchange between CH1 and CH2 according to configuration.

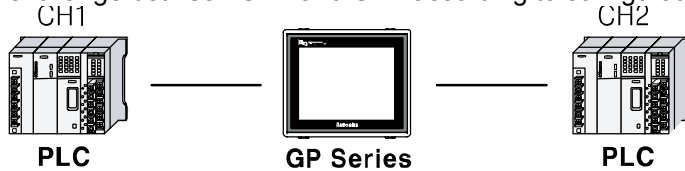

(3) Connection of plural PLCs

It is able to connect same device type to CH1 and CH2 as up to 32 by each.
In this case, GP can link data between CH1-1 to CH1-n and CH2-1 and CH2-n and it is able not to use CH1 or CH2.

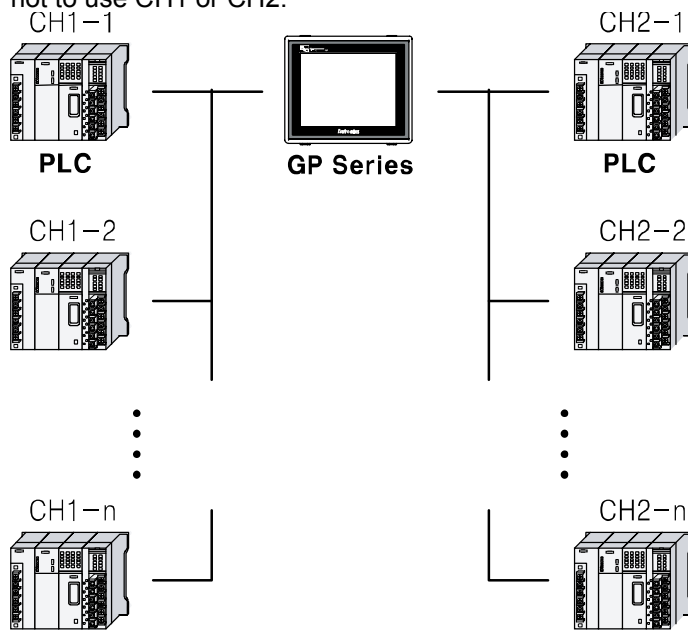

1.5.1 Communication interface

1.5.1.1 Serial interface

(1) Serial port

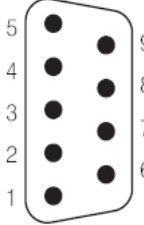
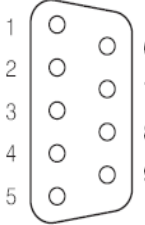
Port	Pin	Port	Pin		
RS232C-A RS232C-B  D-Sub 9Pin Male	1	Non-used	RS422  D-Sub 9Pin Female	1	TXD+
	2	RXD		2	RXD+
	3	TXD		3	Non-used
	4	DTR		4	Non-used
	5	SG		5	SG
	6	DSR		6	TXD-
	7	Non-used		7	RXD-
	8	Non-used		8	Non-used
	9	Non-used		9	Non-used

(2) Serial port setting

Designate the desired settings for below items at [SET ENVIRONMENT] - [PLC SETTING].

Interface	RS232C/RS422
Baudrate	300, 600, 1200, 2400, 4800, 9600, 19200, 38400, 57600, 115200bps
Data length	7, 8 Bit
Stop bit	1, 2 Bit
Parity	ODD, EVEN
Flow control	XON/XOFF, DSR/DTR, NONE

1.6 Unit description

1.6.1 GP-S044

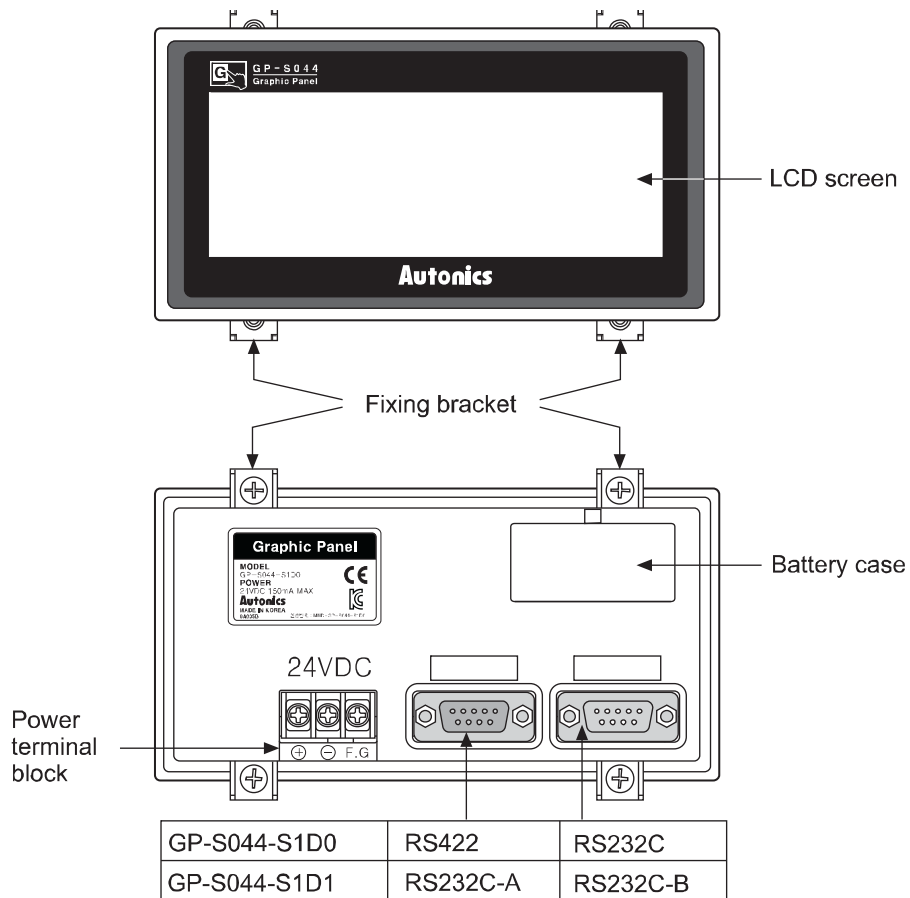

1.6.2 GP-S057

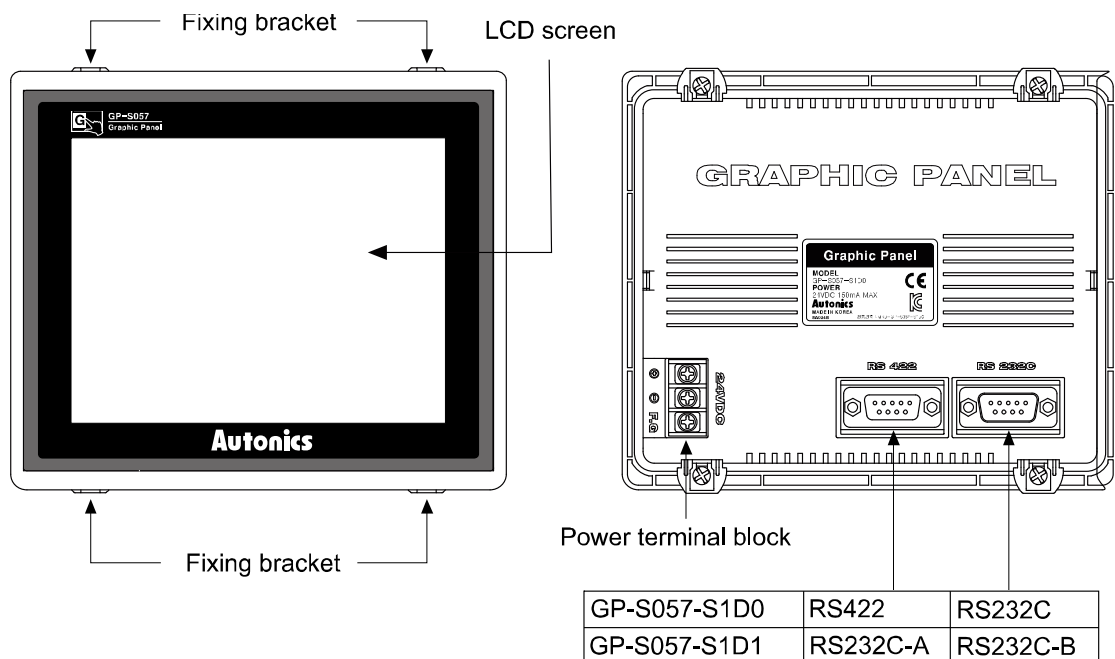

1.7 Dimensions

1.7.1 GP-S044

[Unit:mm]

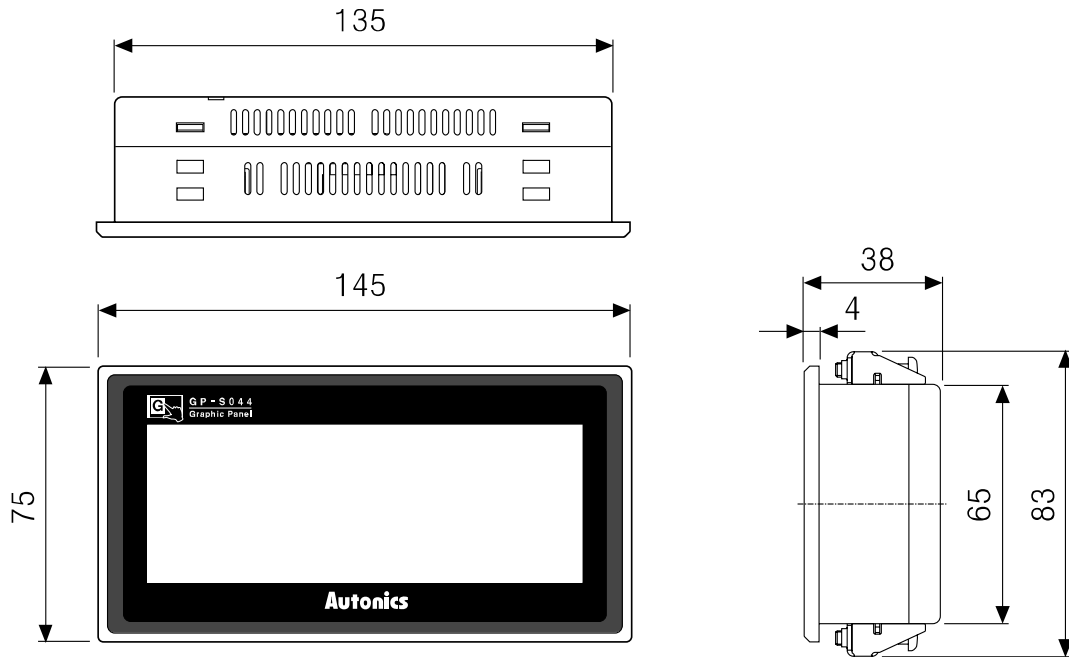

Fixing bracket

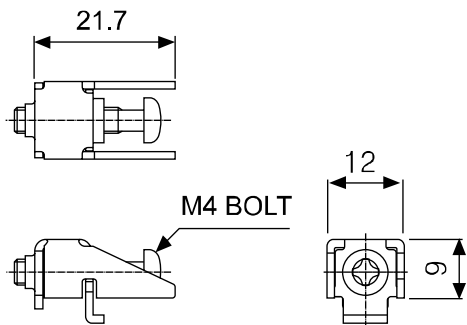

Panel cut-out

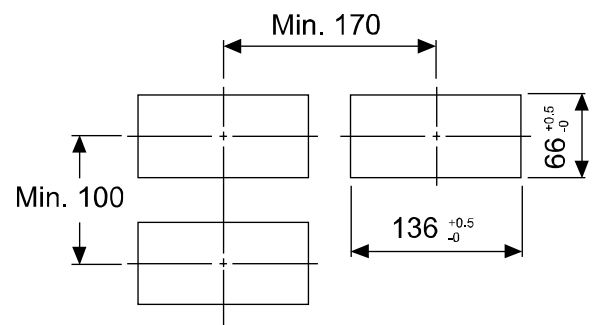

Panel thickness: max 4mm

1.7.2 GP-S057

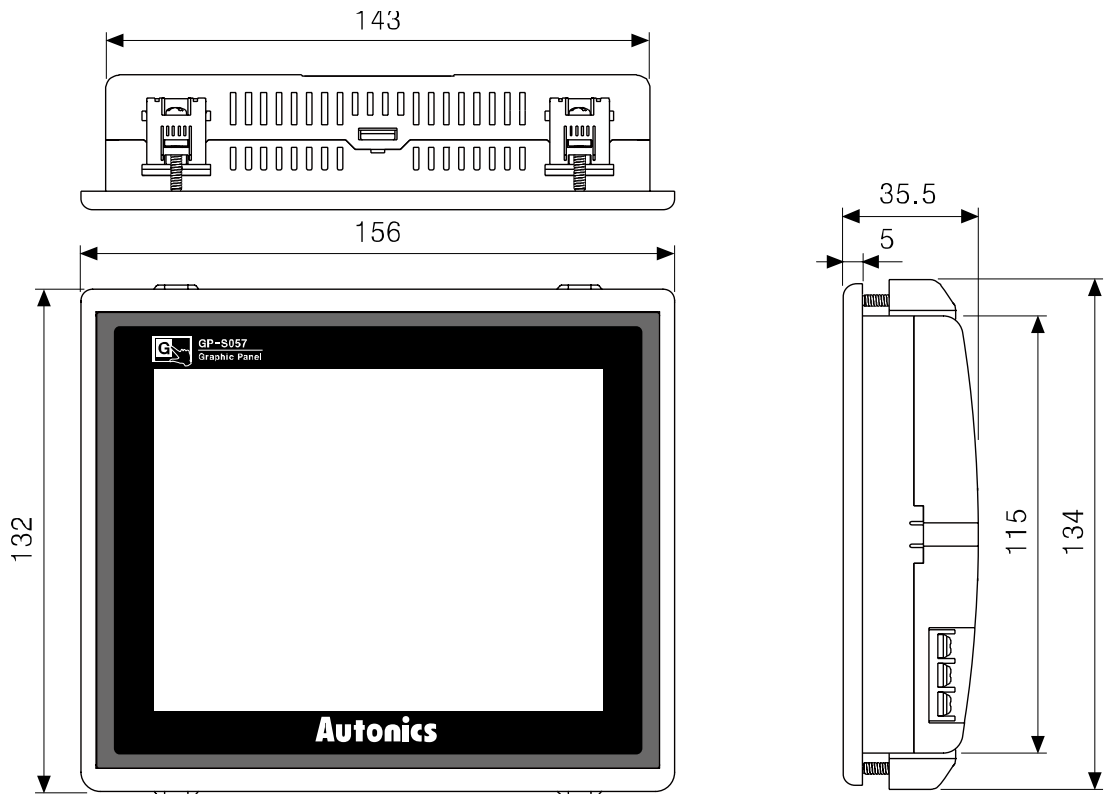

Fixing bracket

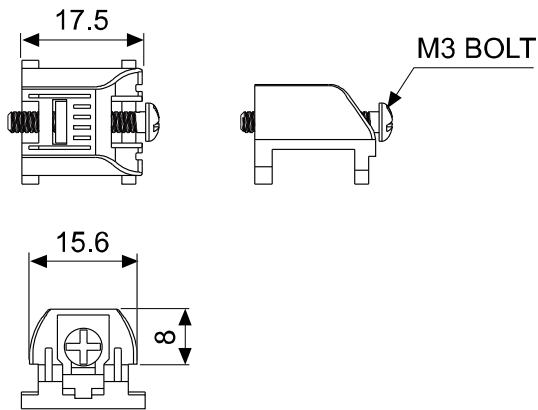

Panel cut-out

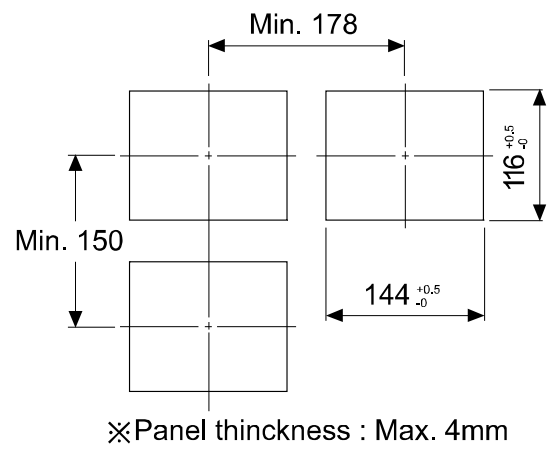

2 Installation

2.1 GP installation

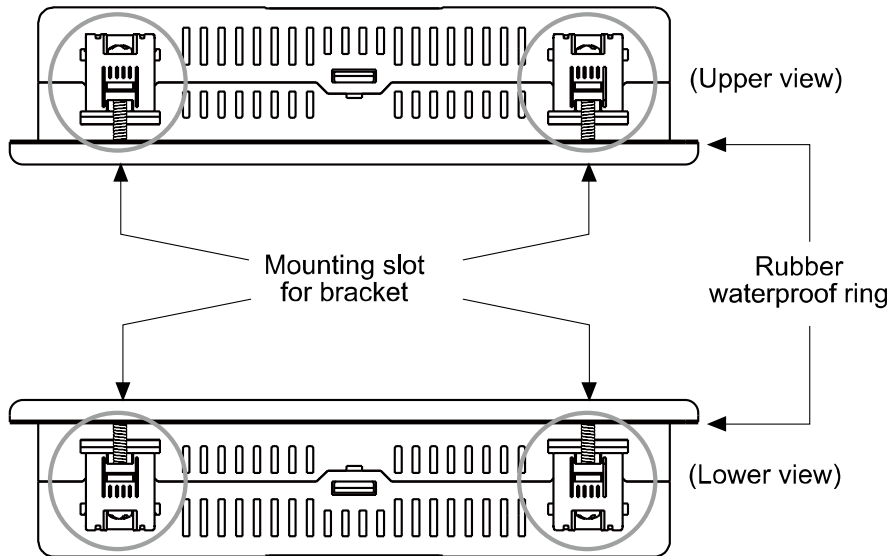

1st Set a rubber waterproof ring after placing the ring's joining part under the GP.

2nd Adhere closely between each edge of the GP and the rings.

3rd Set GP in panel.

4th Set the fix bracket to 4 bracket slots and fix them with screw (GP-S044: M4 Screw, GP-S057: M3 Screw) and tighten them with 0.3N•m torque by screwdriver.

- Mounting bracket with GP-S044

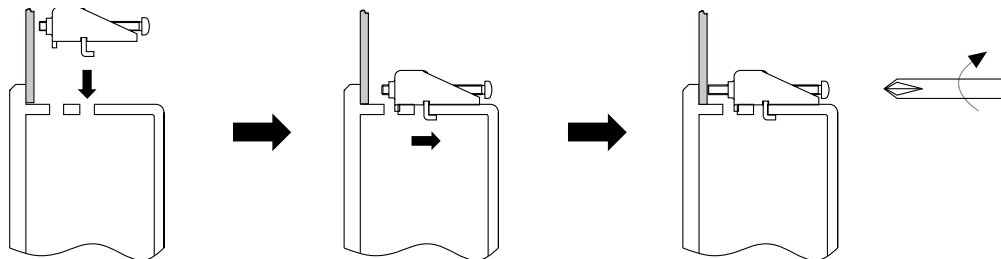

- Mounting bracket with GP-S057

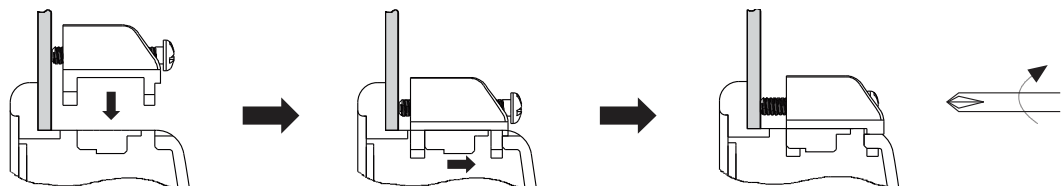

2.2 Power wiring

- For power supply, use the power line of which cross section is at least 0.75mm^2 and use the ground cable of which cross section is at least 1.25mm^2 .
- Use crimp-on type ring terminal with at least 3mm of internal diameter and less than 6mm of external diameter.
- Do not supply power before connecting power line.
- Check power polarity.
- Tighten the terminal screw with 0.5 to 0.8 N•m torque.
- Ground resistance should be less than 100Ω and ground it separately.

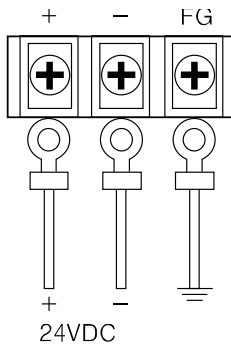

Caution

Caution for power wiring

- Before connecting power line, you must check power polarity.
- Do not connect power when power is supplied.
- Observe following allowable voltage change range of power voltage.

Power voltage	24VDC
Allowable voltage change range	21.6V to 26.4VDC

- When connecting power, supply power by power supply which has inner protection circuit. If the power supply which does not have inner protection circuit is used, you must install protection circuits such as fuse before using this.

2.2.1 Ground wiring

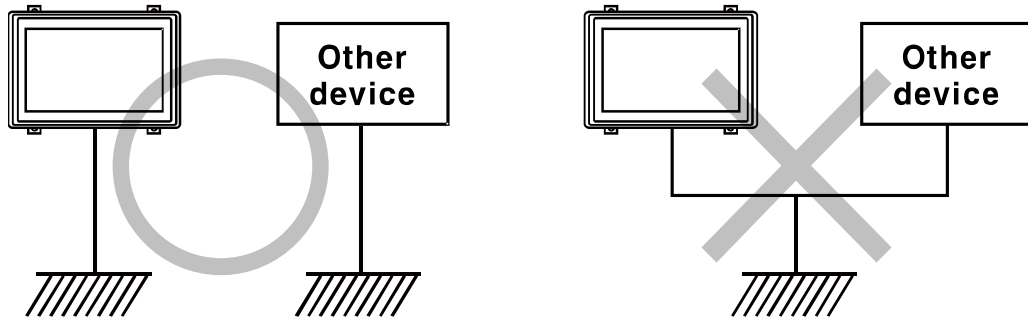

Caution

Caution for ground wiring

- Connect max. 100Ω of ground resistance.
- Diameter of cable for ground wiring connection should be over than 2 mm².
- As above figure, separate from other device's ground wire.

2.3 Battery replacement

Please contact our service center to replace GP battery.

It may cause an explosion or a fire when using improper battery.

3 Device Construction

3.1 Device element

- GP read device [UW, UB]
This area is for controlling graphic panel function.
For further details, refer to 'GP Editor user manual'.
- GP write device [UW, UB]
This area is for displaying graphic panel state.
For further details, refer to 'GP Editor user manual'.
- GP user device [UW, UB]
- This area is for using graphic panel function, general-purpose communication (universal communication) etc.

3.2 Device range

3.2.1 Bit device range

Mark	Name	Range	UB correspond address	Size
UB	READ AREA	UB000000 to UB00014F	UB000000 to UB00014F	00015F bit
UB	WRITE AREA	UB000015 to UB00029F	UB000015 to UB00029F	00015F bit
UB	USER AREA	UB000030 to UB01999F	UB000030 to UB01999F	01969F bit

3.2.2 Word device range

Mark	Name	Range	UB correspond address	Size
UW	READ AREA	UW00000 to UW00014	UW00000 to UW00014	00015 Word
UW	WRITE AREA	UW00015 to UW00029	UW00015 to UW00029	00015 Word
UW	USER AREA	UW00030 to UW01999	UW00030 to UW01999	01969 Word

4 System Organization

4.1 Connection with controller

4.1.1 1:1 organization

1:1 communication is the communication between one GP/LP and one PLC(or controller).

You can organize the system to monitor the action element (device, parameter, etc) status of the connected specified device during executing GP operation.

Both CH1 and CH2 are able to 1:1 communication with tag (Numeral input/display, ASCII input/display).

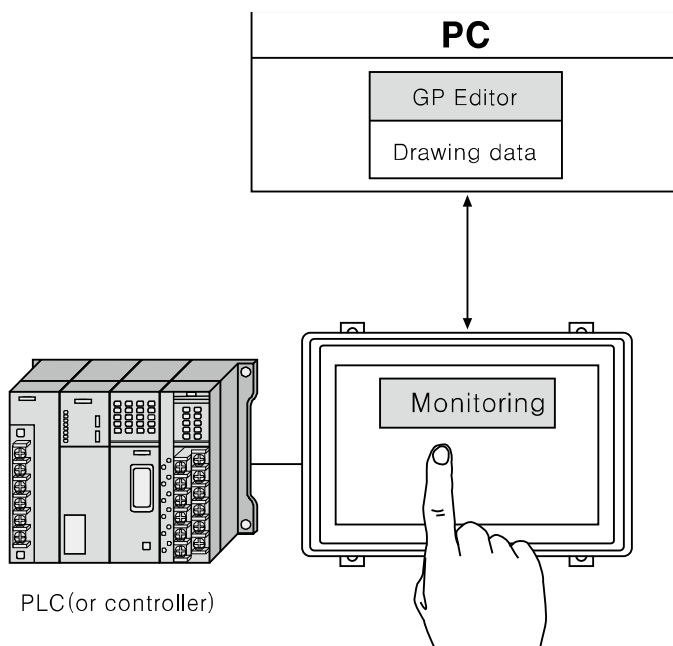

Note

If there are too much draw data, screen processing speed may be reduced. However, control program speed is not affected.

4.1.2 1:N organization

You can construct the system to monitor the action element (device, parameter, etc) status of the connected specified N devices which are same type controllers (PLC etc) during executing GP operation as following figure.

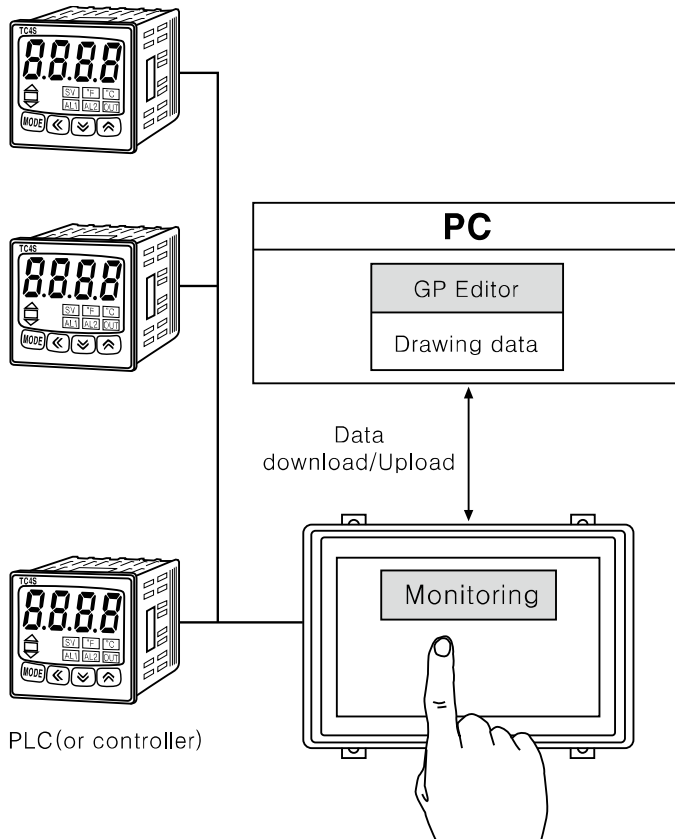

You can connect devices up to 32, it may be different by the product.
 Respond time is different by the connected device during communication, data renewal time may be longer.
 For further details, refer to 'GP, LP user manual for communication'.

4.1.3 Heterogeneous organization

You can organize construct the system to monitor the action element (device, parameter, etc) status of between two devices which are connected at each port as different type controller (PLC, etc) during executing GP operation as following figure.

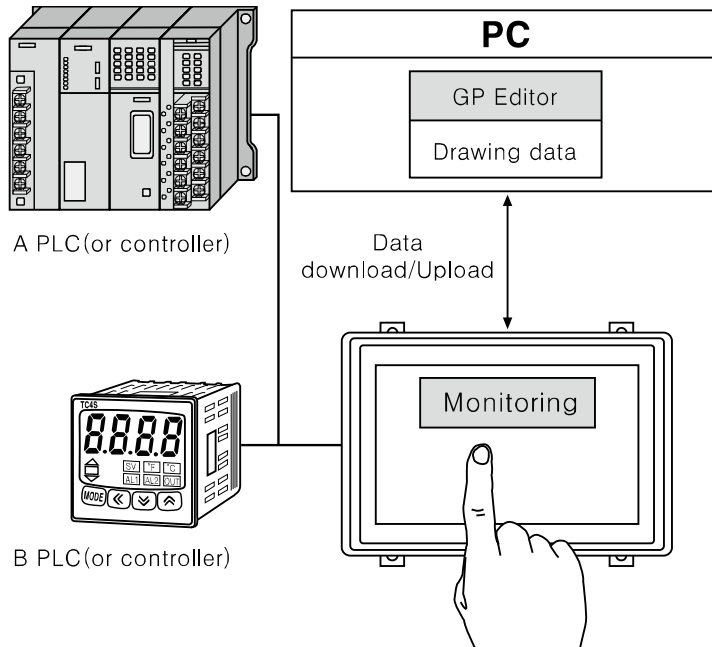

For further details, refer to 'GP, LP user manual for communication'.

4.2 Universal organization

As following figure, you can organize the system to monitor or control host unit data by universal communication during executing GP operation.

For further details, refer to '5.4 Universal protocol' of 'GP,LP user manual for communication'.

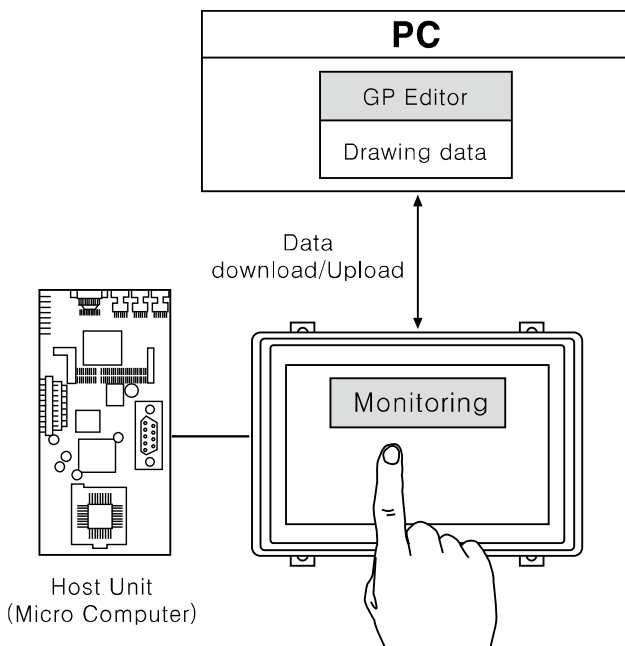

4.3 Connect with barcode, printer

As following figure, you can organize the system to read barcode data by connecting barcode reader, or to print alarm history by connecting serial print during executing GP operation.

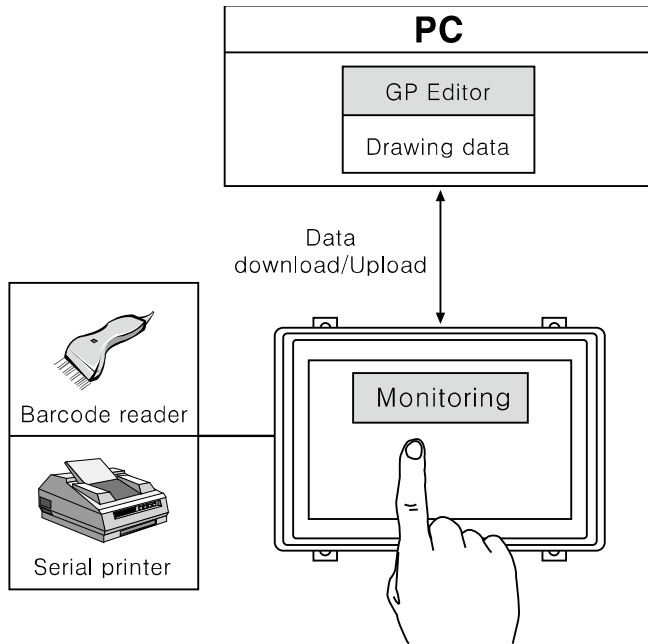

For further details, refer to 'GP, LP user manual for communication'.

4.4 Connect with GP Editor

Communication between PC and GP is available with serial communication.
 Setting method is as below. (Left screens are for GP-S044, right screens are for GP-S057.)

1st Enter system setting menu.

Touch left-upper point as default position of system setting menu.

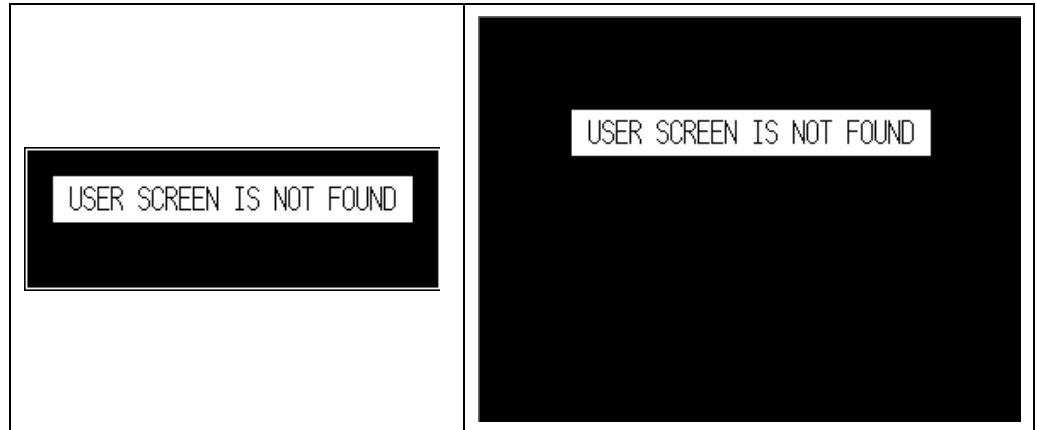

2nd Select [SET ENVIRONMENT].

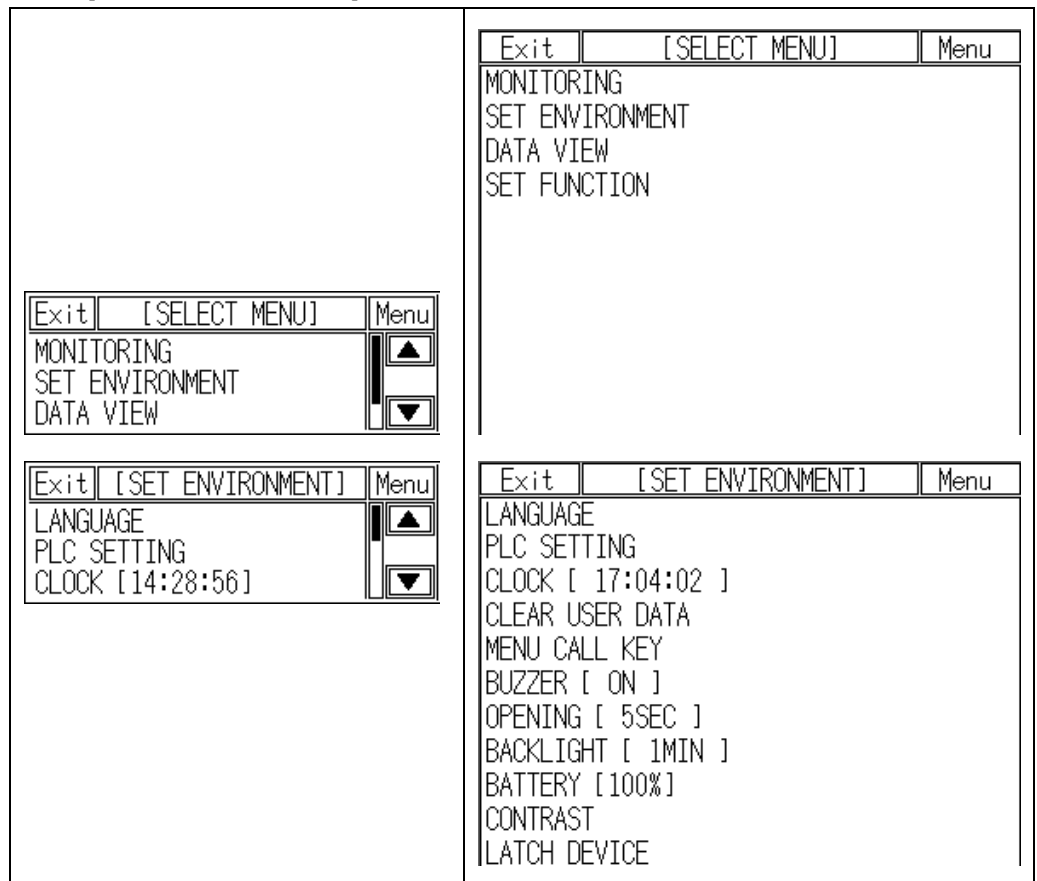

3rd Select [PLC SETTING].

Check that CH2 configuraiton is as 'EDITOR', and connected connection port with GP is as 'RS232C'.

If the configuration is not as 'EDITOR', touch (PROTOCOL) part and cofigure as 'EDITOR'.

Touch this, it rotates in order as EDITOR → PRINTER → BARCODE → MONITOR.

Exit	[PLC SETTING]	Menu
CH1	UNIVERSAL	RS422
CH2	EDITOR	RS232C
GP ST.#	[00]	CH1 ST.# [001]

Exit	[PLC SETTING]	Menu
CH1 INF	UNIVERSAL	v1.4S RS422
B/R	38400bps	FLOW/C XON/XOFF
DATA	[8BIT]	STOP [1BIT] PARITY[NONE]
CH2 INF	EDITOR	RS232C
B/R	115200bps	FLOW/C XON/XOFF
DATA	[8BIT]	STOP [1BIT] PARITY[EVEN]
GP ST.#	[00]	CH1 ST.# [001]

Touch (PORT) area to configure the connection port of GP.

Touch this, it rotates in order as [RS422] and [RS232C]..

Exit	[PLC SETTING]	Menu
CH1	MK-200S(CPU)	RS232C
CH2	EDITOR	RS422
GP ST.#	[00]	CH1 ST.# [001]

Exit	[PLC SETTING]	Menu
CH1 INF	MK-200S(CPU)	v3.6M RS422
B/R	38400bps	FLOW/C XON/XOFF
DATA	[8BIT]	STOP [1BIT] PARITY[NONE]
CH2 INF	EDITOR	RS232C
B/R	115200bps	FLOW/C XON/XOFF
DATA	[8BIT]	STOP [1BIT] PARITY[EVEN]
GP ST.#	[00]	CH1 ST.# [001]

Touch CH2 to set B/R (Baudrate), data, stop, parity, and F/C (Flow control).
 All communication parameters in GP and GP Editor must be set identically.

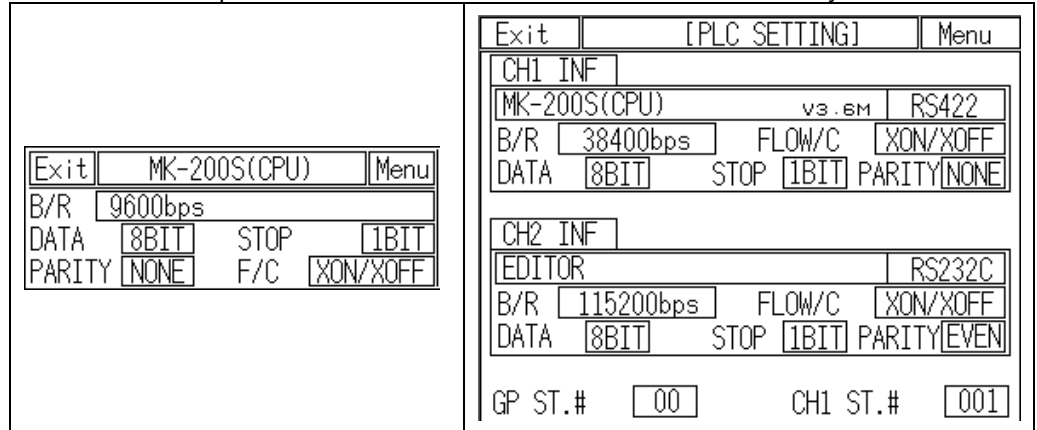

Communication specifications of GP Editor are as followings.

Baudrate	Data bit	Parity bit	Stop bit	Flow control
115200bps	8bit	EVEN	1bit	XON/XOFF

4th After completing communication configuration, you should exit system setting menu and switch user screen to communicate GP Editor.

Touch [Menu], current setting values are saved and it returns to previous menu.

Touch [Exit], current setting values are saved and it returns to user screen after exiting system setting menu.

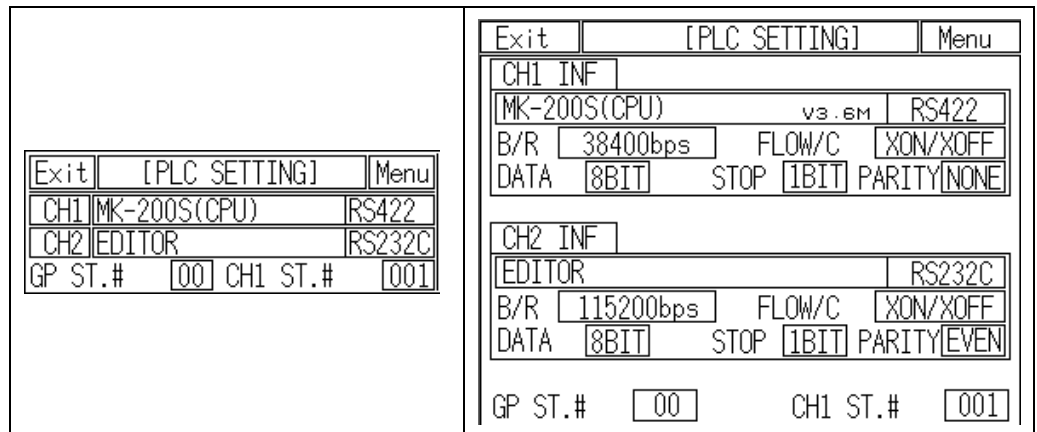

4.4.1 GP Editor configuration

1st Select [Common]-[GP/PLC Type] of GP Editor menu.

Designate GP/LP type as the model name by pull-down menu.

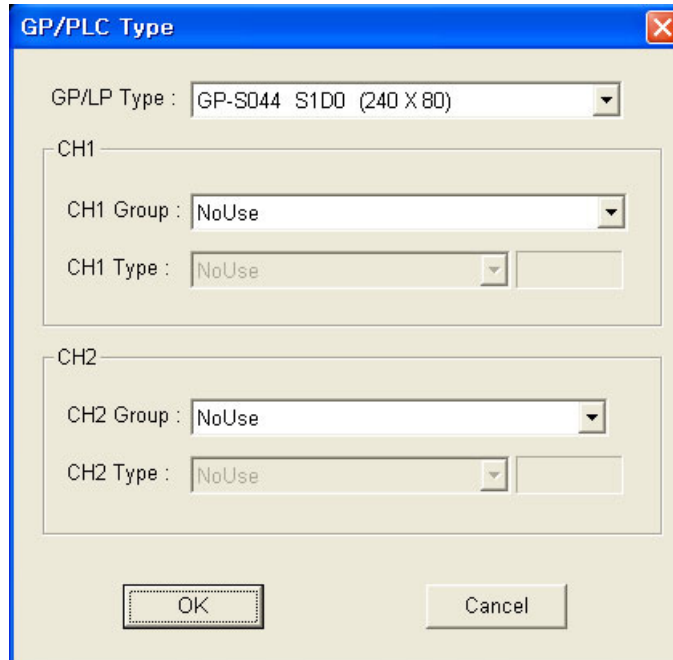

2nd Select [Communication]-[Option] and 'Option' dialog box appears.

Designate communication configuration as same as that of from GP and click [OK].

Only Baudrate is editable, and Data Length, Parity, Stop Bit, and Flow Control are only for checking.

(GP-S044, GP-S057 supports only serial communication, therefore Ethernet and USB communication are not activated.)

For further details of each option, refer to 'GP Editor user manual'.

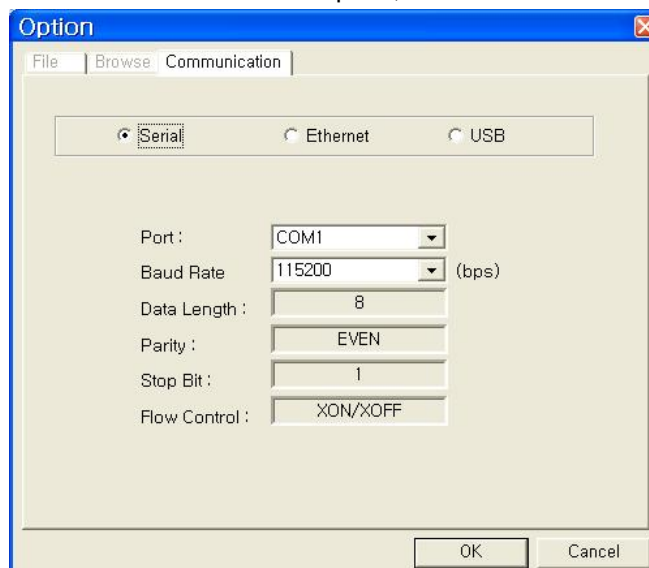

3rd After configuration, connect GP and PC by communication cable to download and upload drawn program from GP Editor.

5 Start up GP

This chapter describes start up procedure from supplying power to GP to switching user screen.

5.1 Checking list before supplying power

Before supplying power to GP, please check the following list.

No	Check	Description
1	Install status	Check waterproof rubber ring is installed.
		Check all 4 fixing brackets are installed.
		Check fixing brackets are fixed with approved tightening torque.
2	Ground	Check ground cable is installed with separated other device ground cable.
		Check there is 3rd grounding.
3	Power cable	Check cable connection by polarity.
		Check the tightening status of screws on terminal.
4	Power	Check power voltage.
		Check this is installed as separated other device power.

5.2 Operation order

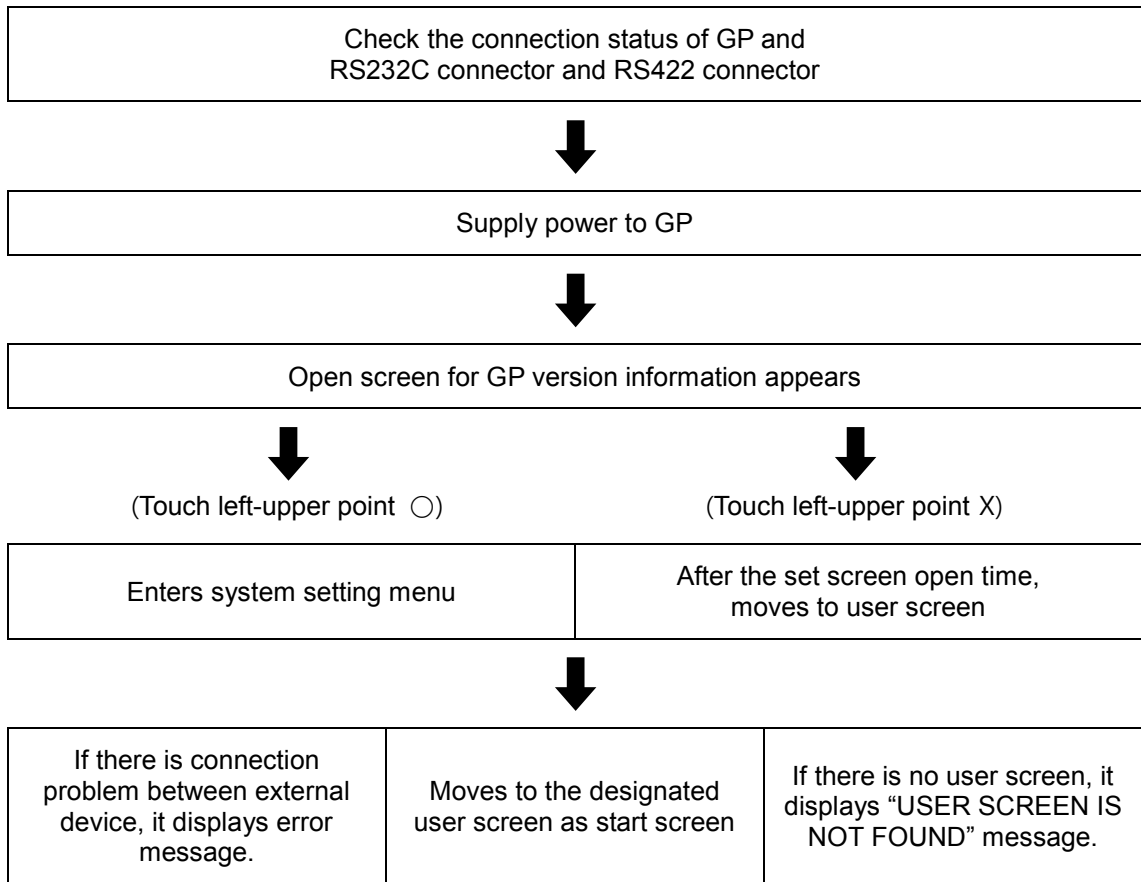

6 System Screen

6.1 Organization of system screen

System setting screen appears for monitoring, set environment, data view and set function by touching system screen calling.

Select each menu and their sub-menu appears.

The system screen organization is as below.

GP-S044 / GP-S057 system setting menu	MONITORING	DEVICE MONITOR
	SET ENVIRONMENT	LANGUAGE
		PLC SETTING
		CLOCK
		CLEAR USER DATA
		MENU CALL KEY
		BUZZER
		OPENING
		BACKLIGHT
		BATTERY
		CONTRAST
	LATCH DEVICE	
	DATA VIEW	BASE SCREEN
		WINDOW SCREEN
		COMMENT
		MEMORY SIZE
		MODEL & VERSION
	SET FUNCTION	DATA TRANSFER
		TIME SWITCH
		PRINT OUT

6.2 Operation of system screen

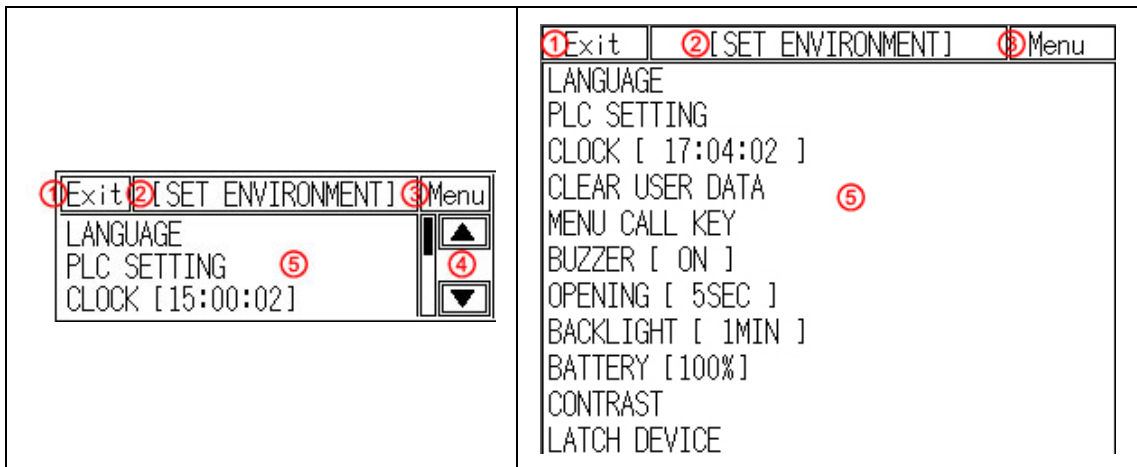

No.	Function and operation
①	Moves from system screen to user screen.
②	Displays current screen's menu.
③	Moves to upper parameter.
④	Moves to up and down items.
⑤	Touch the desired menu and it moves to that menu.



Note

Depending on firmware upgrade, screen organization may be different.

6.3 Device monitor

Device monitor menu is for monitoring inner device of connected device or for designating the value to inner device of GP.

It is able to monitor bit or word device of connected device, special function device, inner bit device of GP, or inner word device area.

Monitorable device is different depending on connected device. Confirm monitorable device by each device from 'GP, LP user manual for communication'.

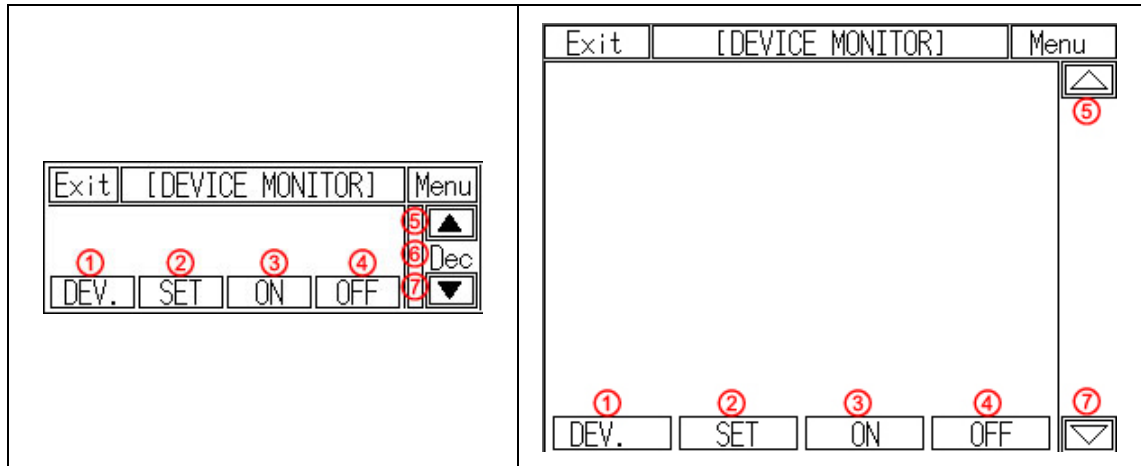

No.	Function and operation
①	Calls input window to select special device set as CH1
②	Calls input window for word device value at cursor.
③	Sets bit device value at cursor.
④	Resets selected bit device.
⑤	Displays close up device list.
⑥	Touch this, Dec or Hex is displayed in order. Dec means decimal, Hex means hexadecimal.
⑦	Displays close down device list.

6.4 Set Environment

SET ENVIRONMENT menu is for checking or re-setting the set status for general operation of GP.

According to each set status, it may affect to GP operation directly/indirectly. As screensaver function, password set and remove is also available depending on user's decision.

6.4.1 Language

User language for GP displays user language for displaying user-defined screen, international character font, English font, vector font. You can designate system language for GP inner system language.

- Supported language: It supports Korean, English, Japanese, Chinese, Russian and the other languages are supported later with upgrade.
- Font type: It supports various fonts by each language.

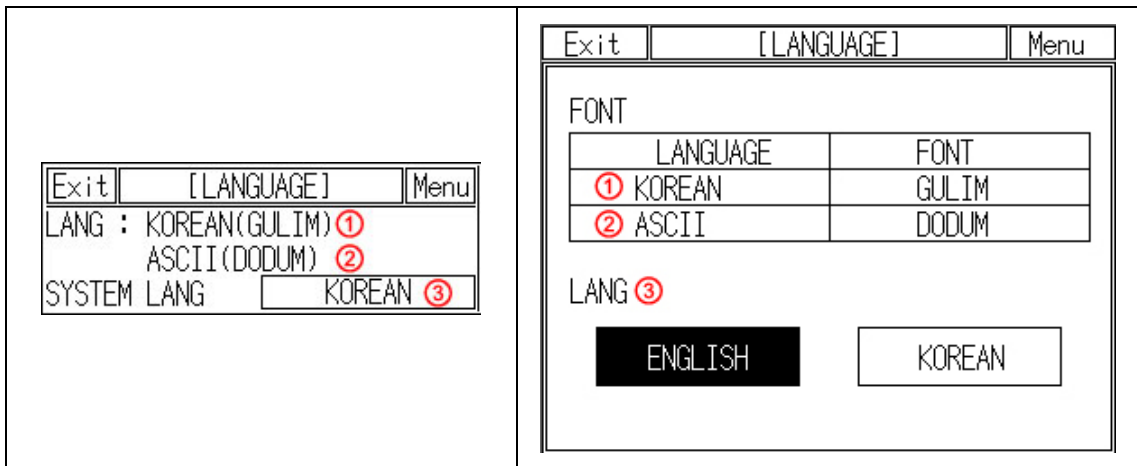

No.	Function and operation
①	Displays designated user language and font.
②	Displays designated ASCII character font.
③	Touch the desired system language as displayed

To change system language, download new fonts from GP Editor.



Note

It prevent error at designing level with using the same font between designing font from GP Editor and used font in GP.

6.4.2 PLC setting

This menu displays connected device to RS232C, RS422 port of GP. You can designate station and connected port by each channel.

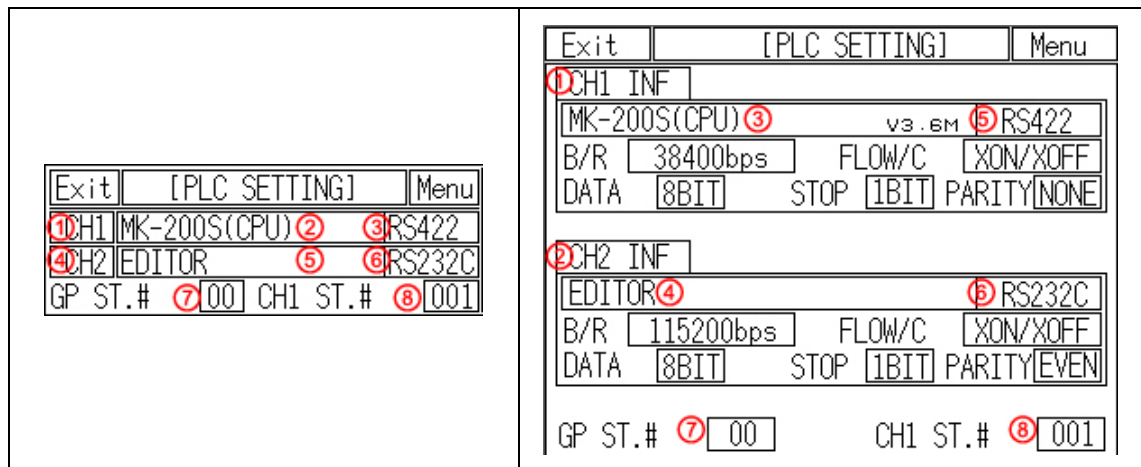

No.	Function and operation
① CH1 configuration line	Displays connected device and connect port for CH1. Touch this to select one from downloaded protocol in EDITOR, PRINTER, BARCODE and designate connect port. (Select RS232C or RS422 or depending on CH2 setting, CH1 may be changed as the other). Depending on the setting, CH1 may be changed as 'No Use'.
② CH1 PLC protocol	Displays PLC protocol of CH1
③ CH1 connect port	Displays connect port of CH1
④ CH2 configuration line	Displays connected device and connect port for CH2. Touch this to select one from downloaded protocol in EDITOR, PRINTER, BARCODE, MONITOR protocol and designate connect port. (Select one of RS232C or RS422 or depending on CH1 setting, CH2 may be changed as the other.) If CH1 is SLAVE, MONITOR does not appear.
⑤ CH2 PLC protocol	Displays PLC protocol of CH2
⑥ CH2 connect port	Displays connect port of CH2
⑦ GP station configuration touch key	Touch this and input key pad for decimal (DEC) appears. It is available the range from 0 to 31.
⑧ Configuration touch key by each channel	Touch this and input key pad for decimal (DEC) appears. It is available the range from 0 to 255.

(1) In case of using only CH1 configured in GP Editor

Exit	[PLC SETTING]	Menu
① CH1	MK-200S(CPU) ③	⑤ RS422
② CH2	EDITOR ④	⑥ RS232C
GP ST.#	[00]	CH1 ST.# [001]

Exit	MK-200S(CPU)	Menu
B/R	[38400bps]	
DATA	[8BIT]	STOP [1BIT]
PARITY	[NONE]	F/C [XON/XOFF]

Exit	[PLC SETTING]	Menu
① CH1 INF		
MK-200S(CPU) ③	v3.6M	⑤ RS422
B/R	[38400bps]	FLOW/C [XON/XOFF]
DATA	[8BIT]	STOP [1BIT] PARITY [NONE]
② CH2 INF		
EDITOR ④		⑤ RS232C
B/R	[115200bps]	FLOW/C [XON/XOFF]
DATA	[8BIT]	STOP [1BIT] PARITY [EVEN]
GP ST.#	[00]	CH1 ST.# [001]

Item	Operation with touching
①, ② Communication configuration by channel	Moves communication configuration setting window for selected connected device. You can designate baudrate, data bit, parity, stop bit, and flow control for each channel.
③ Displays CH1 protocol	Rotates in order as downloaded protocol → EDITOR → PRINTER → BARCODE → UNIVERSAL → DEFAULT protocol
④ Displays CH2 protocol (as EDITOR for default)	Rotates in order as EDITOR → PRINTER → BARCODE → MONITOR (If CH1 is SLAVE, MONITOR does not appear.)
⑤ Displays CH1 connect port (Designates automatically as non-using port in ④)	GP-S0□□-S1D0: RS422 A PORT ↔ RS 232C B PORT GP-S0□□-S1D1: RS232C A PORT ↔ RS232C B PORT
⑥ Displays CH2 connect port (Designates automatically as non-using port in ②)	GP-S0□□-S1D0: RS422 A PORT ↔ RS 232C B PORT GP-S0□□-S1D1: RS232C A PORT ↔ RS232C B PORT

(2) In case of using only CH2 configured in GP Editor

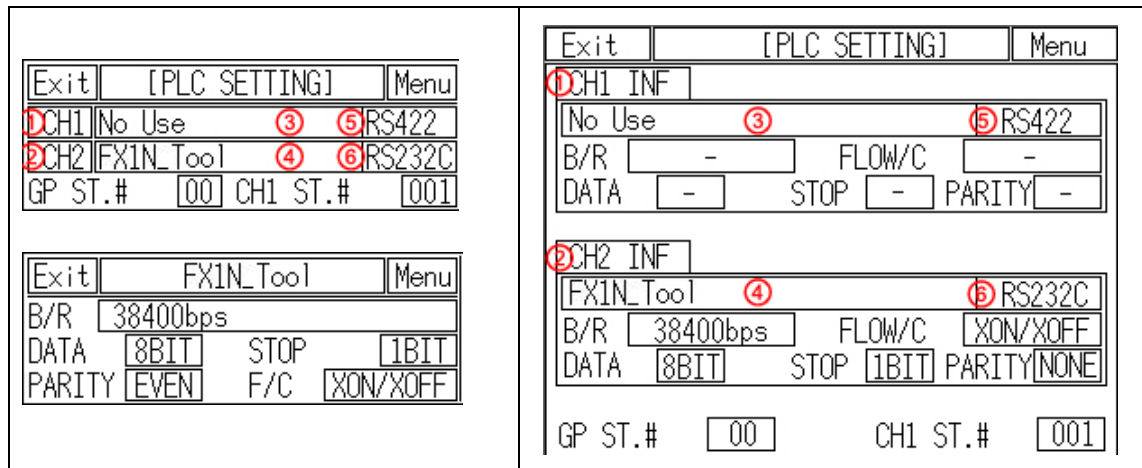

Item	Operation with touching
①, ② Communication configuration by each channel	Moves communication configuration setting window for selected connected device. You can designate baudrate, data bit, parity, stop bit, and flow control for each channel. If CH1 is as NoUse, it is not able to communication configuration.
③ Displays CH1 protocol	Rotates in order NoUse → EDITOR → PRINTER → BARCODE → UNIVERSAL → DEFAULT protocol
④ Displays CH2 protocol. (as downloaded protocol for default)	Rotates in order as downloaded protocol → EDITOR → PRINTER → BARCODE
⑤ Displays CH1 connect port (Designates automatically as non-using port in ④)	GP-S044-T9D6: RS422 PORT ↔ RS232C PORT
	GP-S044-T9D7: RS232C A PORT ↔ RS232C B PORT
⑥ Displays CH2 connect port (Designates automatically as non-using port in ②)	GP- S044-T9D6: RS422 PORT ↔ RS232C PORT
	GP- S044-T9D7: RS232C A PORT ↔ RS232C B PORT

(3) CH1/ CH2 details configuration

Exit	[PLC SETTING]	Menu
①CH1	MK-200S(CPU) ②	RS422
①CH2	FX1N_Tool ②	RS232C
GP ST.#	[00]	CH1 ST.# [001]

Exit	MK-200S(CPU)	Menu
B/R	③ 38400bps	
DATA	④ 8BIT	STOP [1BIT]
PARITY	⑤ NONE	F/C [XON/XOFF]

Exit	FX1N_Tool	Menu
B/R	38400bps	
DATA	8BIT	STOP ⑥ 1BIT
PARITY	EVEN	F/C ⑦ XON/XOFF

Exit	[PLC SETTING]	Menu
①CH1 INF		
⑤MK-200S(CPU)	v3.6M	RS422
B/R	③ 38400bps	FLOW/C ⑦ XON/XOFF
DATA	④ 8BIT	⑥ STOP [1BIT] ⑤ PARITY [NONE]

CH2 INF		
FX1N_Tool		RS232C
B/R	115200bps	FLOW/C [XON/XOFF]
DATA	8BIT	STOP [1BIT] PARITY [EVEN]

GP ST.#	[00]	CH1 ST.# [001]
---------	------	----------------

No.	Function and operation
①	Touch this, detailed configuration screen for designated operation mode appears.
②	<p>Designate operation mode.</p> <ul style="list-style-type: none"> CH1,2 protocol: Communication mode for set PLC by GP and GP Editor by each port. EDITOR: I/O mode for downloading user-designed data from GP Editor PRINTER: Print mode for printing alarm history of GP (For more details, refer to 'GP LP user manual for communication') BARCODE: Input mode for reading data from barcode. (For more details, refer to 'GP LP user manual for communication') MONITOR: Available only in CH2. Monitoring mode for PLC which is connected to GP from PC directly. GP is as transmitter by transmitting data from PC to PLC and data from PLC to PC. In case of MITSUBISHI FX-Series, editor mode is available for monitoring. NoUse: Displayed only not using appropriate CH.
③	<p>Designate baud rate.</p> <p>Supports 300, 600, 1200, 2400, 4800, 9600, 19200, 38400, 57600, 115200 bps</p>
④	<p>Data: Designate data bit</p> <p>Supports 7 bit, 8 bit.</p>
⑤	<p>Parity: Designate parity type.</p> <p>Supports even, odd, or none parity.</p>
⑥	<p>Stop bit: Designate stop bit.</p> <p>Supports 1 bit, or 2 bit.</p>
⑦	<p>Flow control: Designate data flow control.</p> <p>Supports XON/ XOFF, or DSR/DTR.</p>

6.4.3 Clock

This menu is for setting or checking current time.

No.	Function and operation
①	Designate user designate time and data from current time. <ul style="list-style-type: none"> • 0 to 9: Input set time. • CLR: Cancel set value input and cursor disappears. • ENT: After completing configuration, moves cursor to next input. Touch [ENT], cursor moves year, month, day, hour, min, sec in order. When new date type is designated in GP Editor, cursor moves to display order.
②	Displays current set date and time in real time. Touch to reset item; year, month, day, hour, min, sec, and cursor appears to input.

 **Caution**

Designated time is applied for clock, alarm history, alarm list, etc which are related with time.

If external power is cut, current time is maintained by battery. If there is time error with connected external power, battery may be discharged. Please check battery status from [SET ENVIRONMENT]-[BATTERY] of system setting menu.

6.4.4 Clear USER DATA

This menu is for initializing user data and setting values of GP.
Be sure that once deleted data cannot recover.

Be sure that once deleted data cannot recover.

Especially for saving alarm history contents, by GP Editor upload alarm history and alarm frequency with checking 'Alarm History (Alarmhistory.txt)' and 'Alarm Frequency (Alarmfrequency.txt)' in tag box of 'Monitor Data Upload' dialog box from [Communication]–[Upload] menu to save txt files. If GP and serial printer is connected, you can print alarm history in [SET FUNCTION] – [PRINT OUT] of system setting menu.

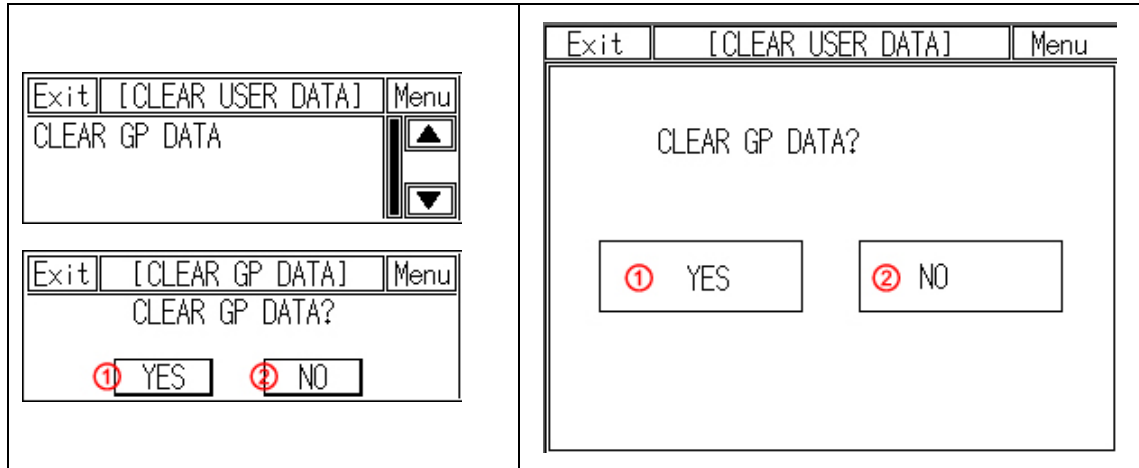

No.	Function and operation
①	Initializes every data of screens of GP, part, comment, and common configuration information. After completing initializing, user screen displays 'USER SCREEN IS NOT FOUND' message.
②	Exits this menu without initializing data.



Caution

During downloading user-designed data and ladder data, if download is stop in the middle of progressing by power and cable statue, initialize the data of GP and download it again.

6.4.5 Menu call key

Check or select the position of system setting menu key to enter from user screen.

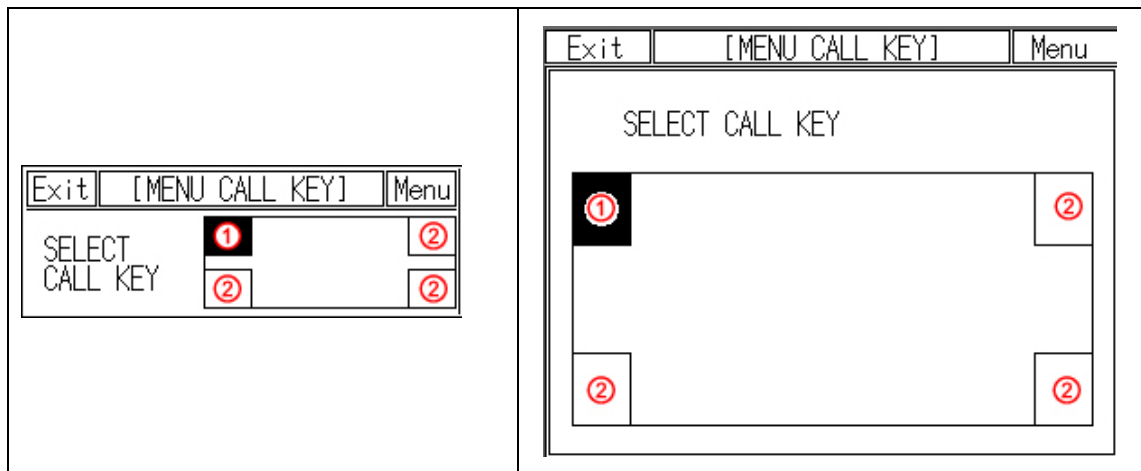

No.	Function and operation
①	Displayed that this position is already designated for system setting menu key.
②	You can designate system setting menu key up to two keys. If two keys for system setting menu is set, you should touch both two keys simultaneously to enter system setting menu.



Note

In case screen direction is vertical (bottom side from front screen is placed at left status), default position of system setting menu key is placed at left-upper point.
 Touch left-upper point as soon as re-supply power and it enters to system setting menu.
 If there is numeral/ASCII input or touch key tag at system setting menu key position, it executes only tag operation and it does not enter system setting menu.

6.4.6 Buzzer

Designate buzzer on or off for touch key operation, numeral or ASCII input touch, system setting menu touch, communication start and complete, or alarm.

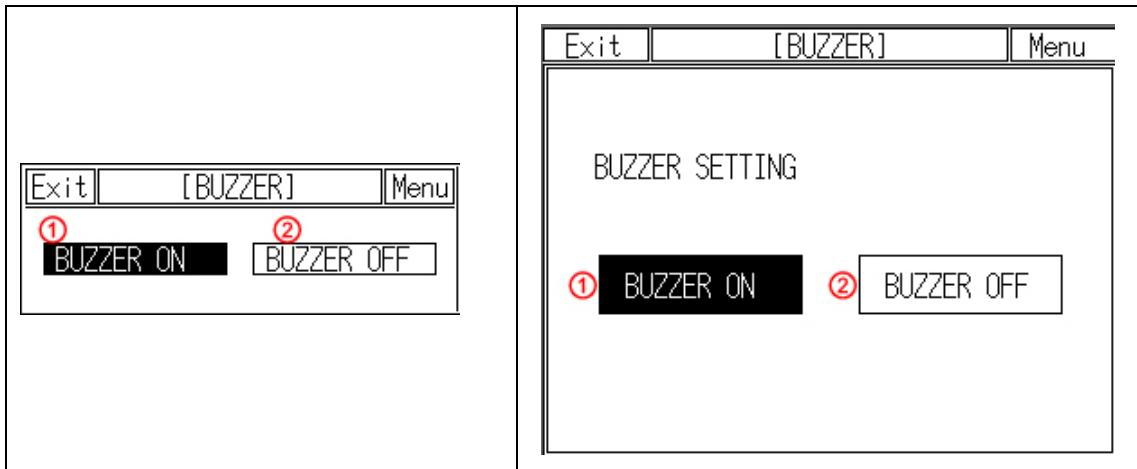

No.	Function and operation
①	Touch this, buzzer turns on. It displays contrast item is not set.
②	Touch this, buzzer turns off.

6.4.7 Opening time

Menu for set time of open screen when supplying power.

No.	Function and operation
①	Set time of open screen. Set range is from 0 sec to 60 sec. <ul style="list-style-type: none"> ▪ 0 to 9: Touch the desired time. ▪ CLR: Cancel the set input, input cursor disappears. ▪ ENT: Set the input value.
②	Displays the set time for switching from open screen to user screen. Touch the time to reset, input cursor appears to set.



Note

Open screen displays to check current basic information(firmware releasing date, and version).

6.4.8 Backlight

Designate back light off time.

If there is no touch on screen of GP until off time of backlight, LCD backlight is OFF. Backlight is ON again when user touches it. In this case touching is only for backlight ON and the other operation is not valid.

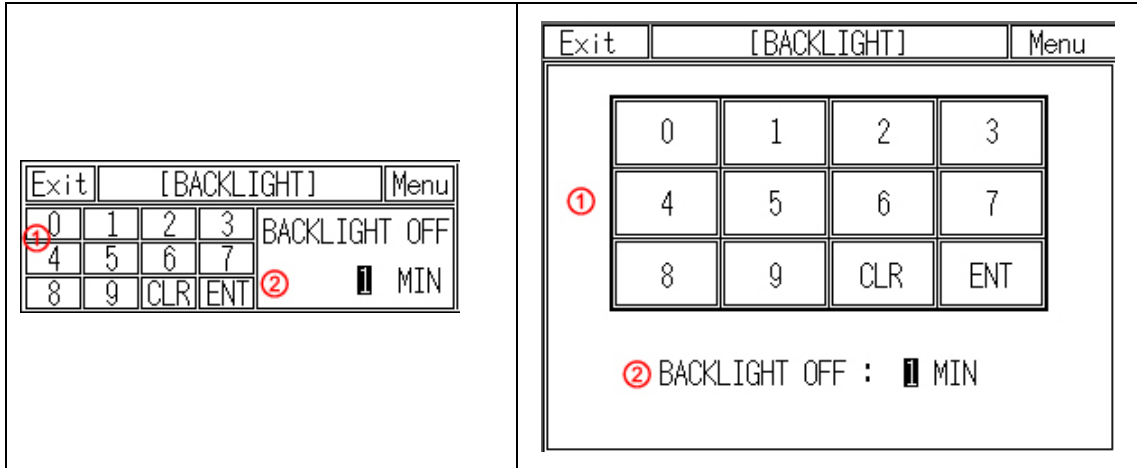

No.	Function and operation
①	<p>Designate back light off time if there is no touch input.</p> <ul style="list-style-type: none"> 0 to 9: Touch the desired time. CLR: Cancel the set input, input cursor disappears. ENT: Set the input value. <p>Set range is 0 min to 99min. If 0 is set, backlight is not OFF Depending on the status from [System information device]–[Backlight control bit of read device] in GP, it controls the designated operation. Backlight setting and operation is available only when backlight control device is SET (ON). If backlight control device is RESET (OFF), it does not operate irrespectively menu setting.</p>
②	<p>Displays the set time for back light off. Touch the time to reset, input cursor appears to set.</p>

6.4.9 Battery

You can check battery remaining as percentage (%).

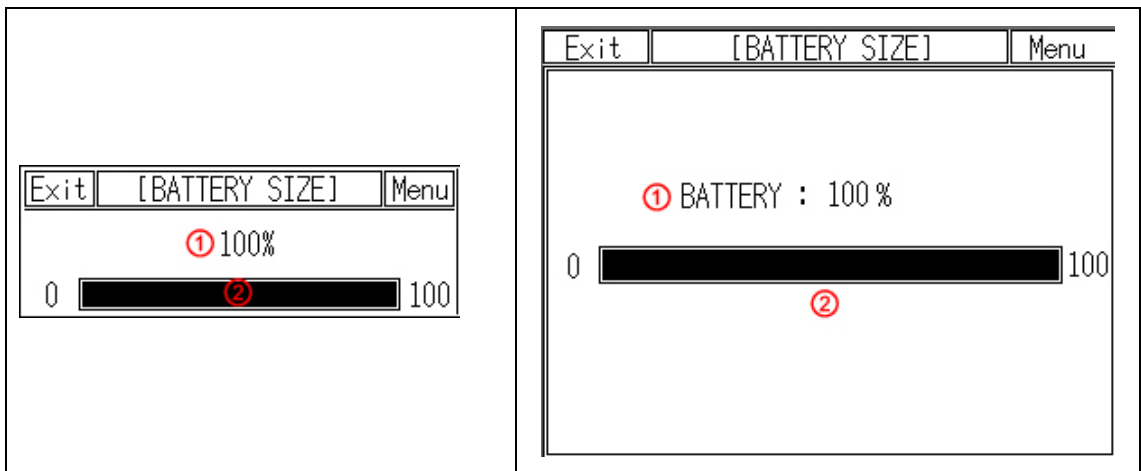

No.	Function and operation
①	Displays battery remaining with bar graph
②	Displays battery remaining with 0 to 100% as numerical percentage.



Note

When battery remaining is 0%, 'Bat Low' message flashes.

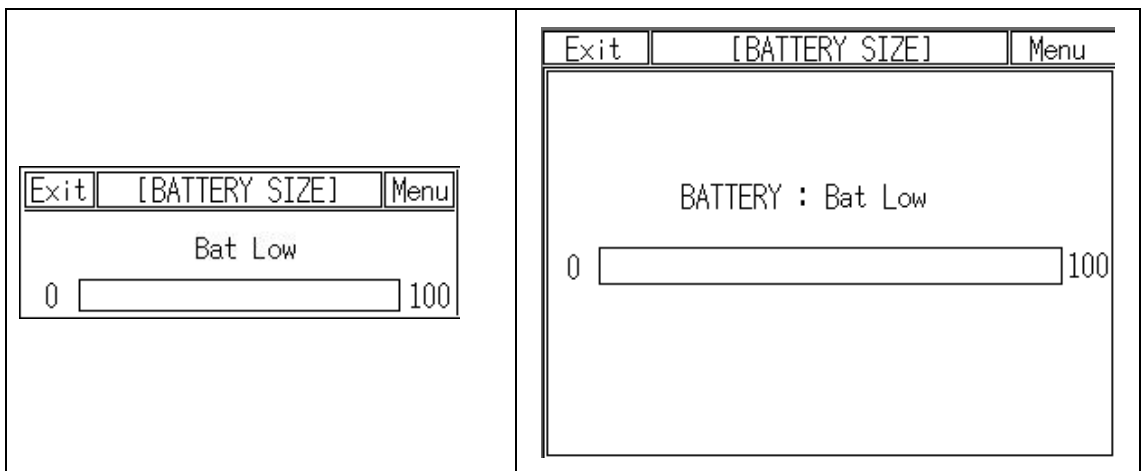

6.4.10 Contrast

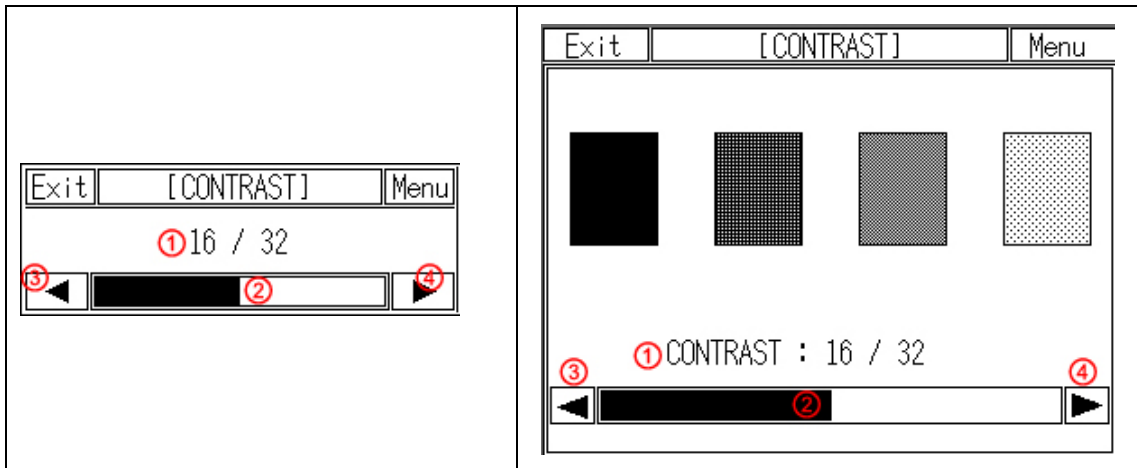

No.	Function and operation
①	Displays current set stauts.
②	Displays set screen contrast ratio as bar graph.
③	Touch this, it decreases contrast ratio.
④	Touch this, it increases contrast ratio.

6.4.11 Latch device

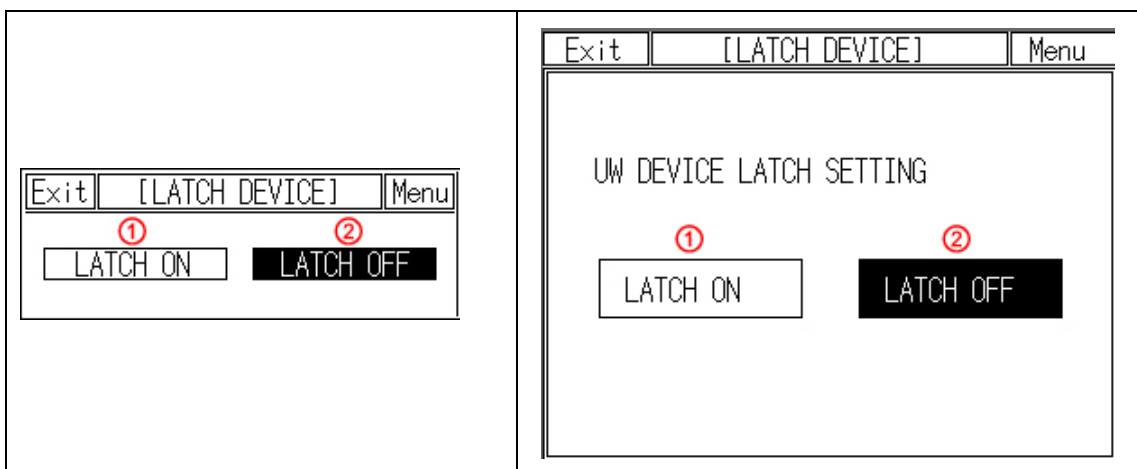

No.	Function and operation
①	Designate LATCH DEVICE as ON. When power OFF, UW device is maintained by GP battery.
②	Designate LATCH DEVICE as OFF.

6.5 Data View

6.5.1 Base screen

This menu displays screen number and screen title list for base screen. Touch the desired screen, you can check designed status of the screen.

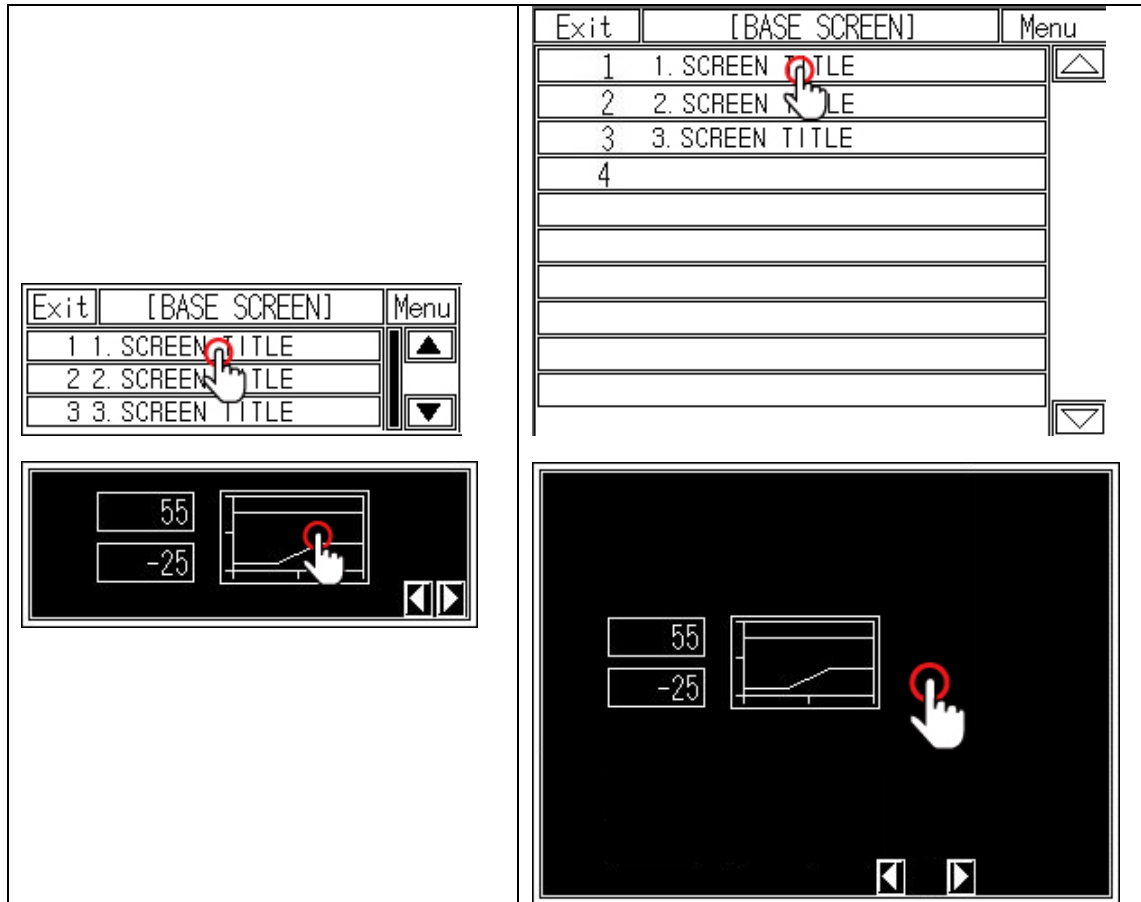

Note

By checking base screen from the list, the display object of the selected base screen operates normally but the input object of the selected screen does not operate.

6.5.4 Memory size

This menu displays total disk capacity (512Kbyte) and available capacity of GP.

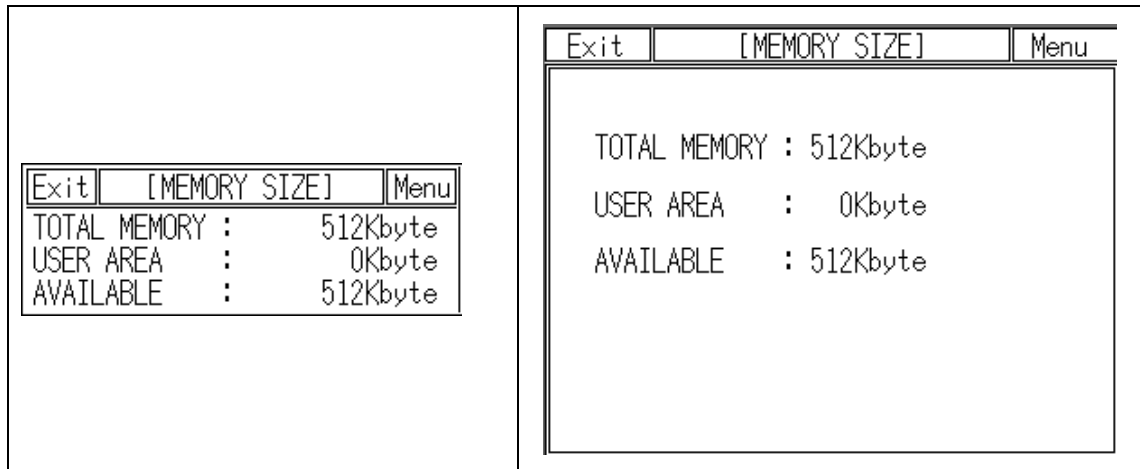

6.5.5 Model & Version

This menu displays GP model name and firmware version.

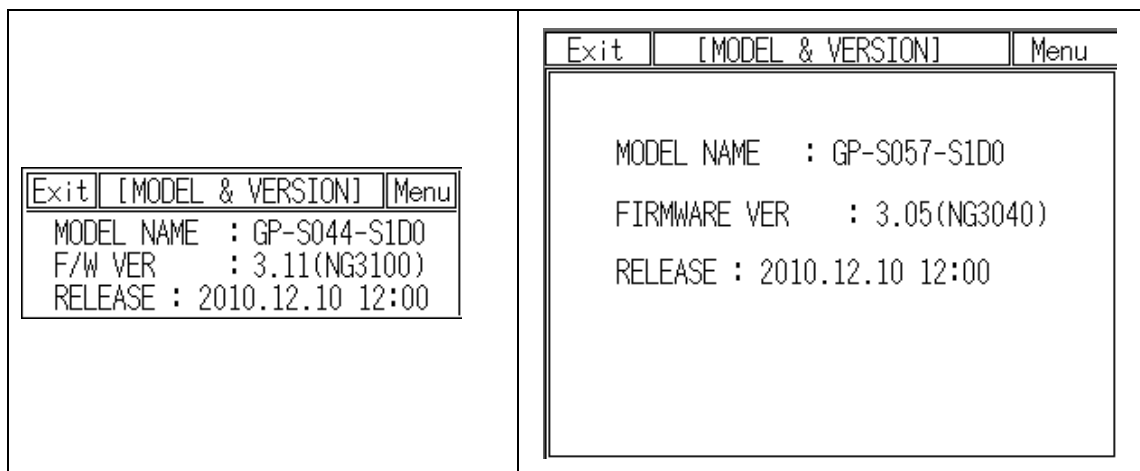

6.6 Set Function

6.6.1 Data transfer

This menu screen is displayed during communicating (download/upload) between GP Editor of PC and GP.

- Waiting

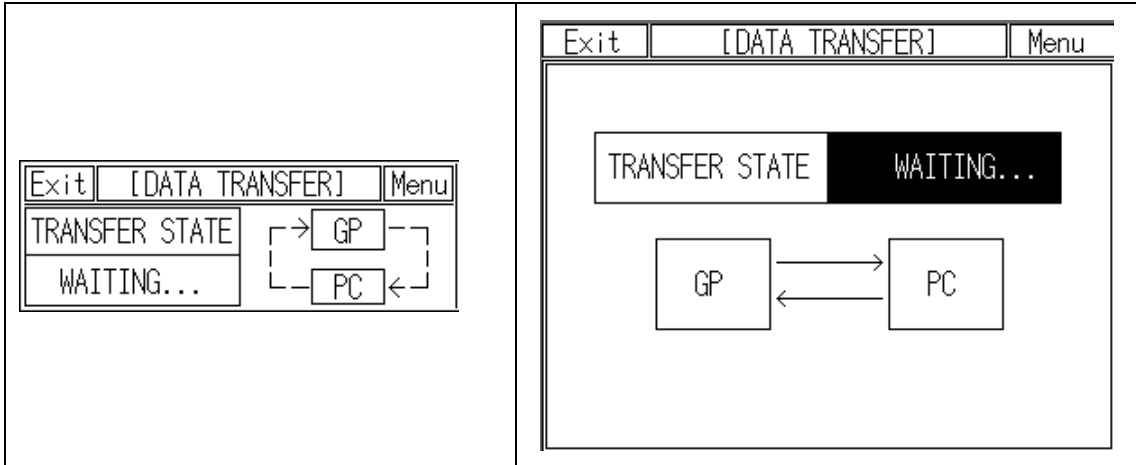

- Download

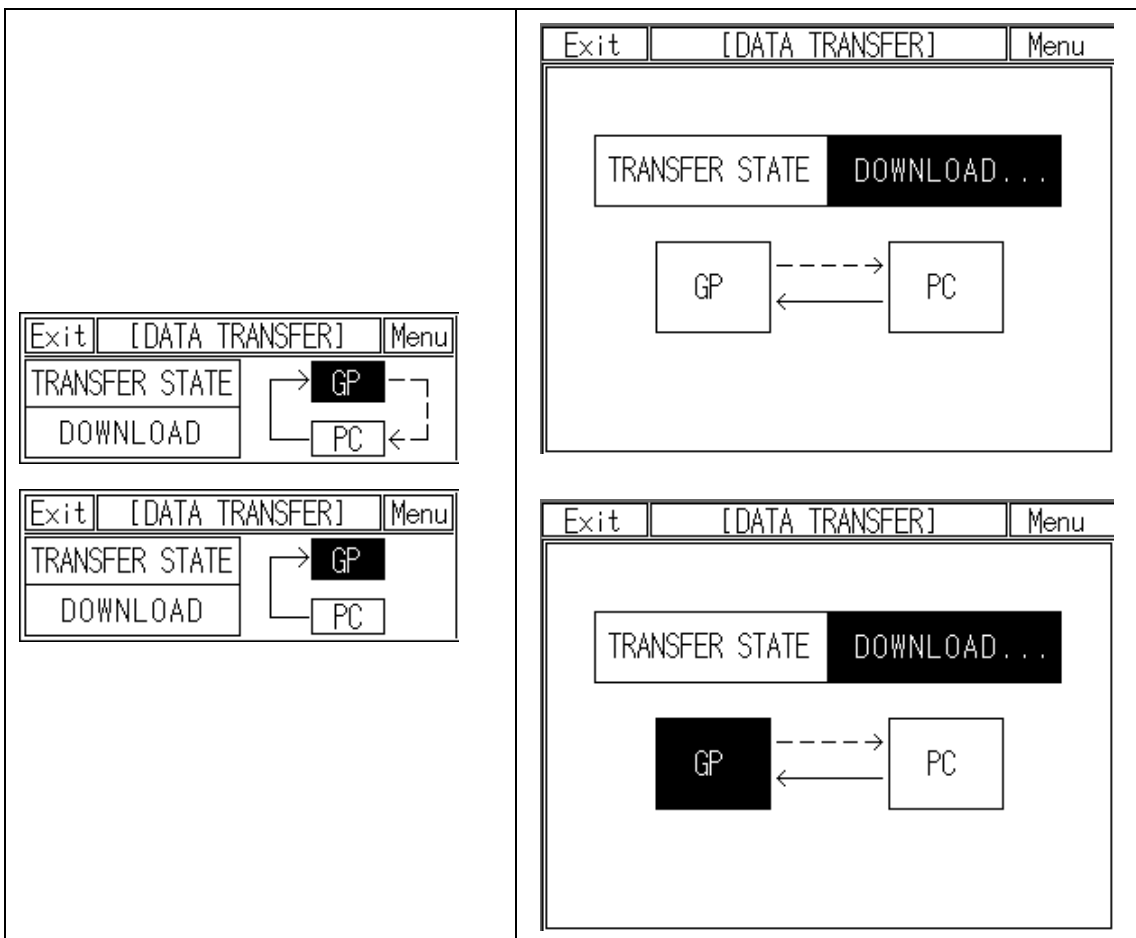

Upload

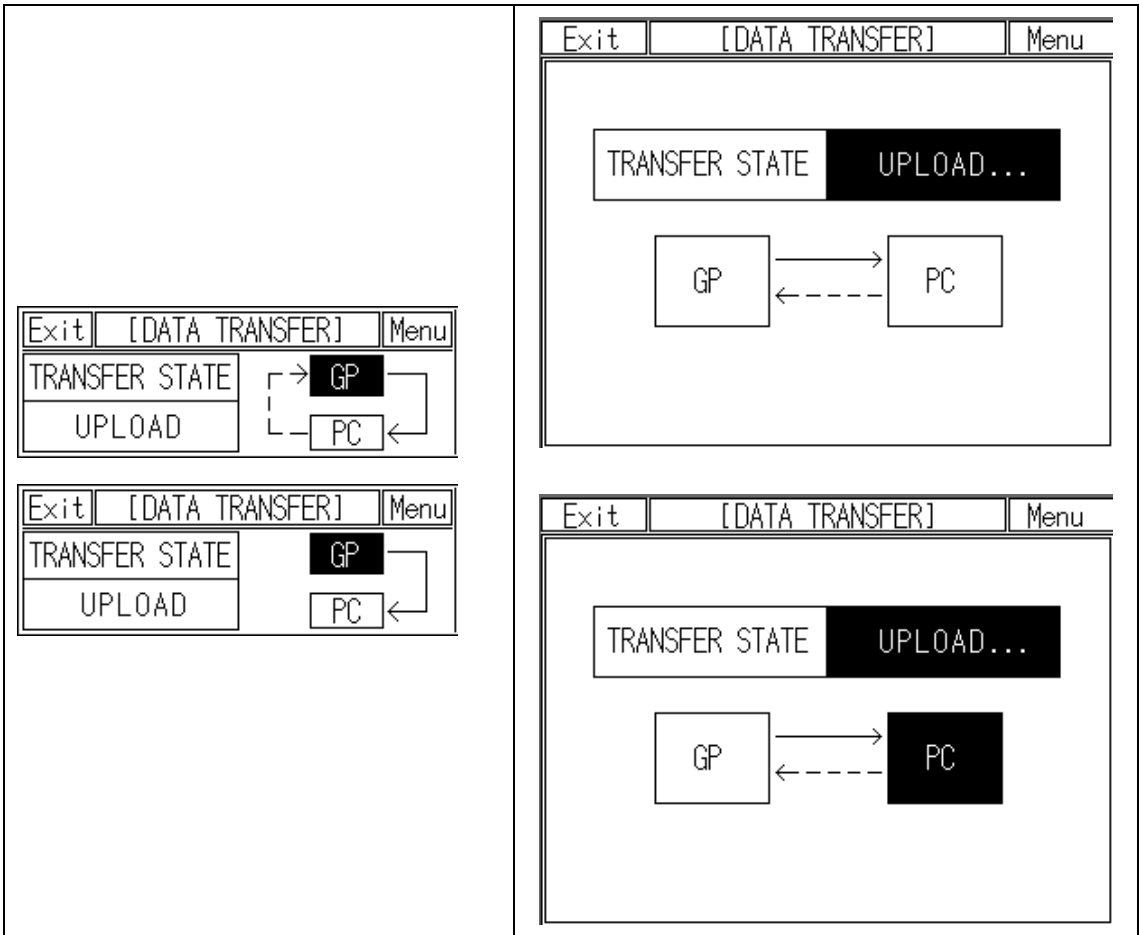

Touch this, numeral input key pad appears to input start time and end time.

The sequence of screens is as follows:

- Screen 1:** A grid with columns 'Exit', '[TIME SWITCH]', and 'Menu'. The first row contains 'ACT1 Device', 'ACT2 Device', 'ACT3 Device', and 'ACT4 Device'. The second row contains 'ACT5 Device', 'ACT6 Device', 'ACT7 Device', and 'ACT8 Device'. A hand icon is shown touching 'ACT1 Device'.
- Screen 2:** A table with columns 'Exit', '[TIME SWITCH]', and 'Menu'. It lists 8 rows, each with 'DEVICE', 'START', and 'END' fields, all containing '??:??:??'. A hand icon is shown touching the first row.
- Screen 3:** A screen titled '[SET ACT 1]'. It has columns 'Exit', '[TIME SWITCH]', and 'Menu'. Below the title are days of the week: SUN, MON, TUE, WED, THU, FRI, SAT. 'MON', 'WED', and 'FRI' are shaded. Below are two rows: 'ACT START TIME' with a circled 2 and '2:15:00', and 'ACT END TIME' with a circled 3 and '4:17:30'.
- Screen 4:** A screen titled '[ACTION]'. It has columns 'Exit', '[TIME SWITCH]', and 'Menu'. It shows a 'WEEK' selection area with 'MON', 'WED', and 'FRI' shaded. Below is an 'ACTION' section with two input fields: 'START TIME' with a circled 2 and '2 : 15 : 00', and 'END TIME' with a circled 3 and '4 : 17 : 30'.

No.	Function and operation
①	Touch desired day of the week. Shaded item (MON, WED, FRI) are selected.
②	Designate action start time. Touch this, input key pad appears.
③	Designate action end time. Touch this, input key pad appears.

7 User Screen

User screen is a base or window screen designed with GP Editor.

7.1 Screen specification

(1) Base screen size

Base screen size is as entire area of the screen.

GP-S044 is 240 X 80dot, GP-S057 is 320 X 240dot.

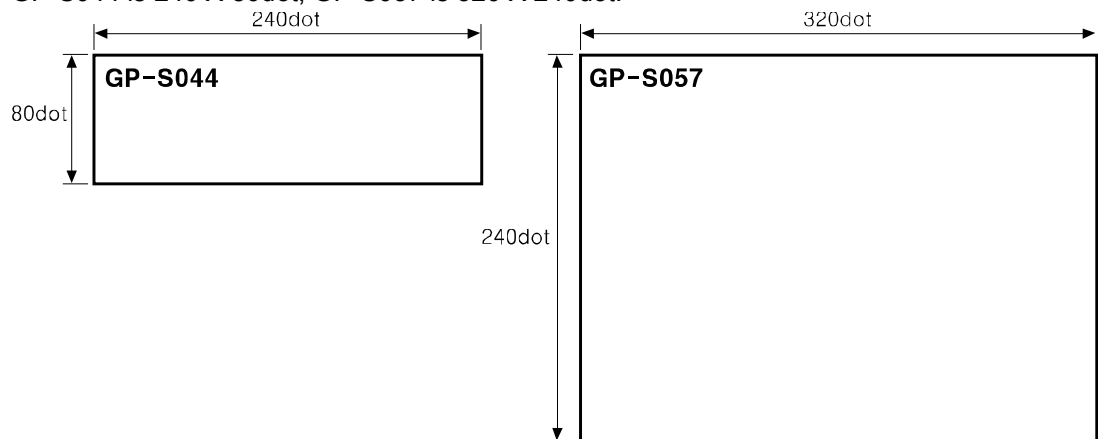

(2) Window screen size

Window screen size is min. 16X20dot to max. 240X80dot for GP-S044 and for GP-S057, min. 20 X 20dot to max. 320 X 240dot.

You can designate window screen size and its position in GP Editor, and also assign individual screen number for window screen as base screen number.

(3) Screen position

Content	Base screen		Window screen	
	GP-S044	GP-S057	GP-S044	GP-S057
Start position of screen (left-upper point)	(0,0)	(0,0)	(0, 0) to (239, 79)	(0, 0) to (319, 239)
End position of screen (right-lower point)	(239, 79)	(319, 239)	(15, 19) to (239, 79)	(19, 19) to (319, 239)
Position by screen type	Base screen size is not changeable and has fixed coordinate value.		If window screen is over maximum size, right- lower point moves automatically to the end point of screen. Therefore, it may be different between user-defined position and window screen position.	

(4) Screen number and the number of screen

Item	Base screen	Window screen
Screen number	Enable to designate from 1 to 500 range	
The number of designable screen	500	
The number of downloadable screen	500 ※1	3 ※2

※1. If designed base screen capacity is over user data area, data transmission does not operates normally. Please check designed data capacity and download it again.

※2. Designed window screen is for user-defined key pad. In this case, maximum number of download screen to GP is 3.

7.2 Screen display object**(1) Available display object by screen type**

	Base screen	Window screen
Available display object	Line, rectangle, circle, text, bitmap, numeral display, ASCII display, numeral input※1, ASCII input※1, clock, comment list, alarm history※1, alarm list※1, part display, lamp display, line graph, trend graph, bar graph, statistic graph, panel meter, touch key	Line, rectangle, circle, text, bitmap, numeral display, ASCII display, clock, comment list, part display, lamp display, line graph, trend graph, bar graph, statistic graph, panel meter, touch key

※1. These are displayed only on base screen .

(2) Limit the number of display objects by screen type

Except below some objects, there is no limit the number of displaying for all tags on screen. However, too many objects on a screen may cause reducing monitor speed remarkably.

- Object which can exist only one on a screen:
Alarm history, alarm list with scroll option, trend graph, and line graph
- Object which cannot exist on a screen:
Alarm history, alarm list with scroll option, trend graph and line graph

(3) Limit the number of display objects by project

It is available to use objects with memory store function (trend graph, alarm list) on a project max.16.

7.3 Screen switching

(1) Screen switching device

The designed user screen in GP Editor has own number and it is downloaded to GP, GP monitors base screen switching device periodically and decides to be displayed base screen. Screen switching device is designated in GP Editor. It recognizes the current value of device assigned to switching device of base screen as screen number, it is displayed the screen. In order to make same as the real screen number and device reference value for screen access, it is designed to display screen no.1 when the current value of device is '0'. [Operation when D0 [Current value] device as base screen number device]

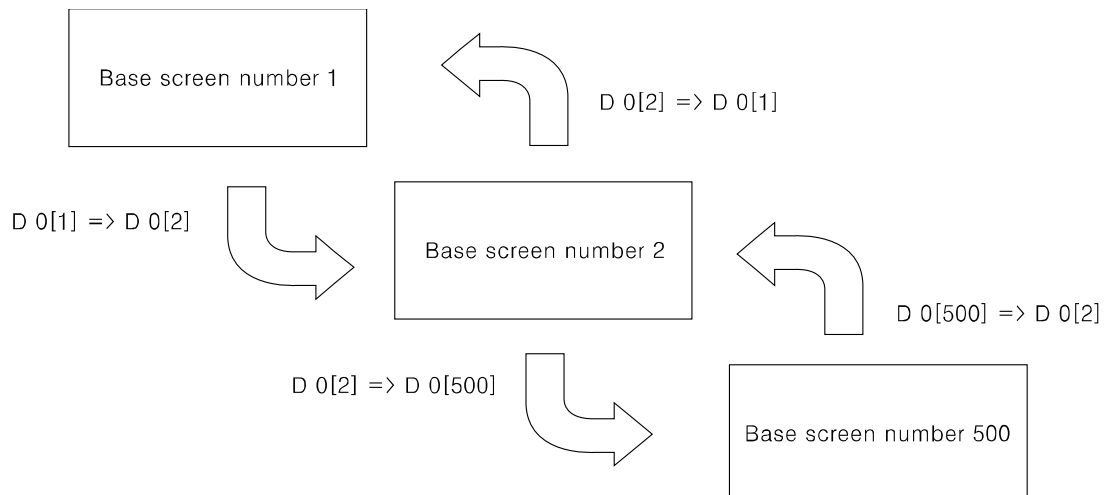

If there is no screen number corresponding the device value of screen data, error message appears.

(2) Screen switching methods

It is switched to the appropriate screen when changing screen switching device value. It is changed as below methods.

- 1) Using touch key for switching screen

There are switching functions of touch key operations as follows.

 - ◆ Switching to the fixed screen
 - ◆ Switching to the previous screen
 - ◆ Switching to the adjacent lower number of screen
 - ◆ Switching to the adjacent upper number of screen
- 2) Numeral input

It is switched to the appropriate screen inputting screen number in screen switching device using numeral input tag.
- 3) Device monitor

It is switched from device on device monitor of system screen to the appropriate screen inputting the value in screen switching.
- 4) Screen switching a screen by PLC program

When changing a screen switching device on PLC program, GP switches it into the appropriate screen.

7.4 Overlap window function

GP monitors user-defined of 2 screen overlap devices and overlaps the screen satisfying current value of the device on a base screen.

In order to use screen overlap function, designate the device for overlap window in GP Editor.

The overlap window is displayed in order of window 1, 2 on current screens as below. In case, the value of overlap window device is exceeded the range (1 to 500) or does not exist, the window is not displayed.

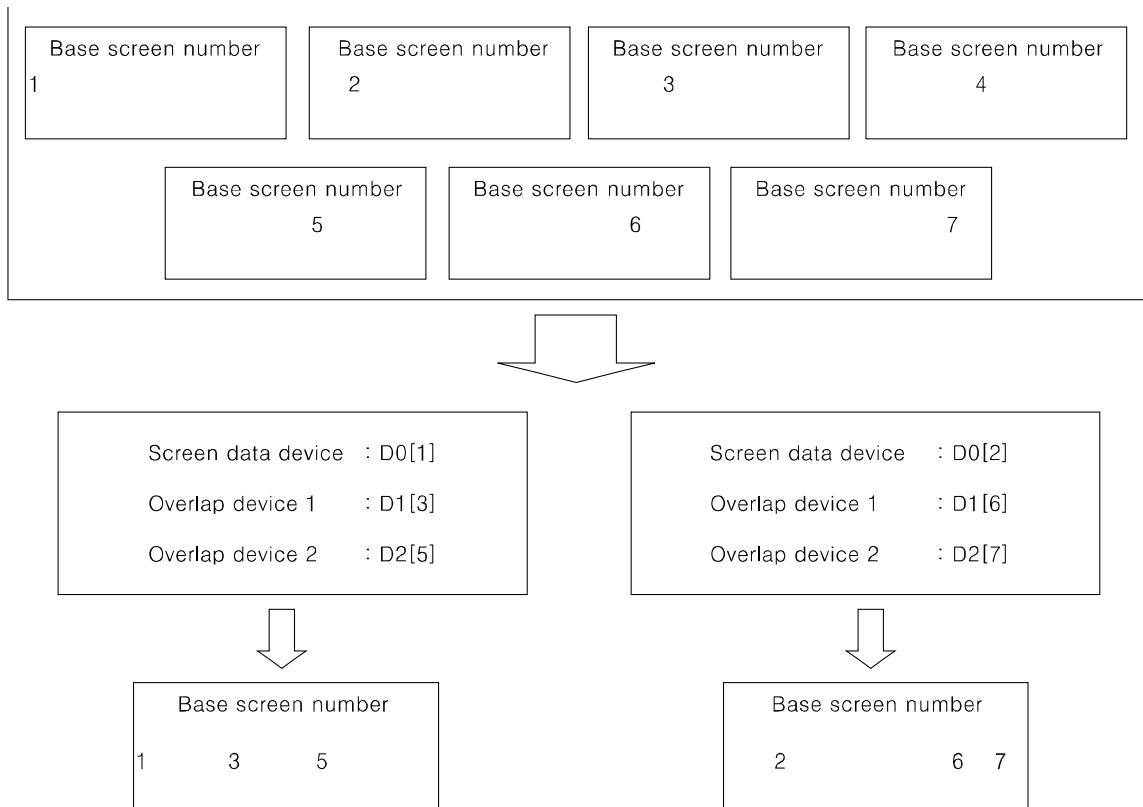



Ex.

It discibes when screen calling device is D 0, overlap window 1 device is D 1, overlap window 2 device is D 2.

All user-defined base screen numbers: 1, 2, 3, 4, 5, 6, 7, 8

- In case of $D0=1, D1=3, D2=11$,

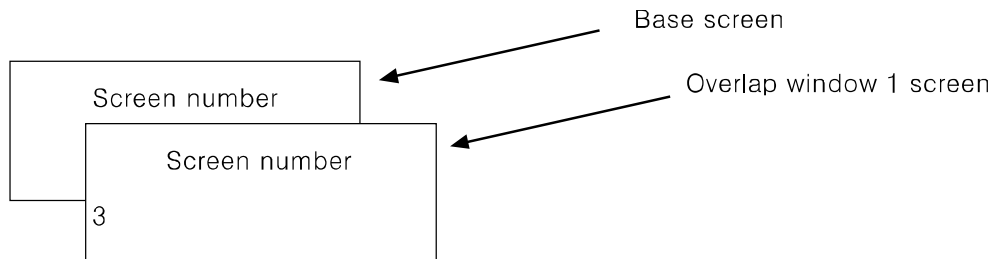

Overlap window 2 is not overlapped because the value of overlap window 2 device is not an existing base screen number.

- In case of $D0=1, D1=3, D2=5$,

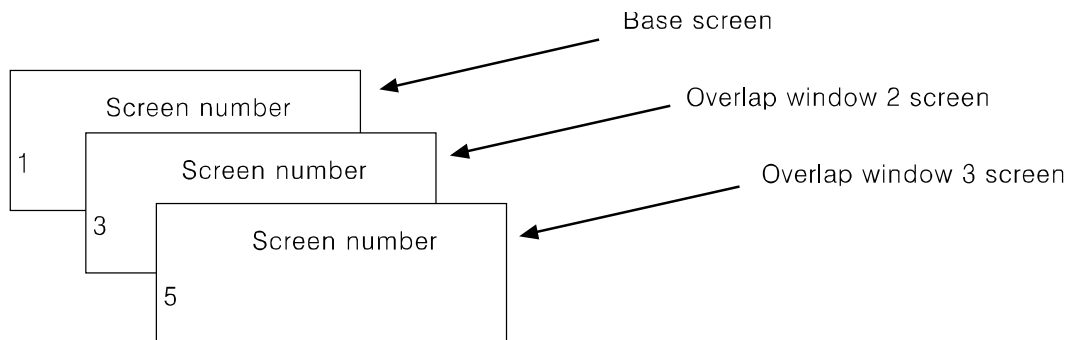
**Caution**

Various tags of overlap screen in the upper part can cover lower part of tags and they are not shown. If touch keys or input tags are overlapped, the upper one is only operated when it touched.

7.5 Device connection status display

If configured connect device is not connected or connection has error, at [SYSTEM SETTING] - [SET ENVIRONMENT] - [PLC SETTING] menu displays error message as following screen.

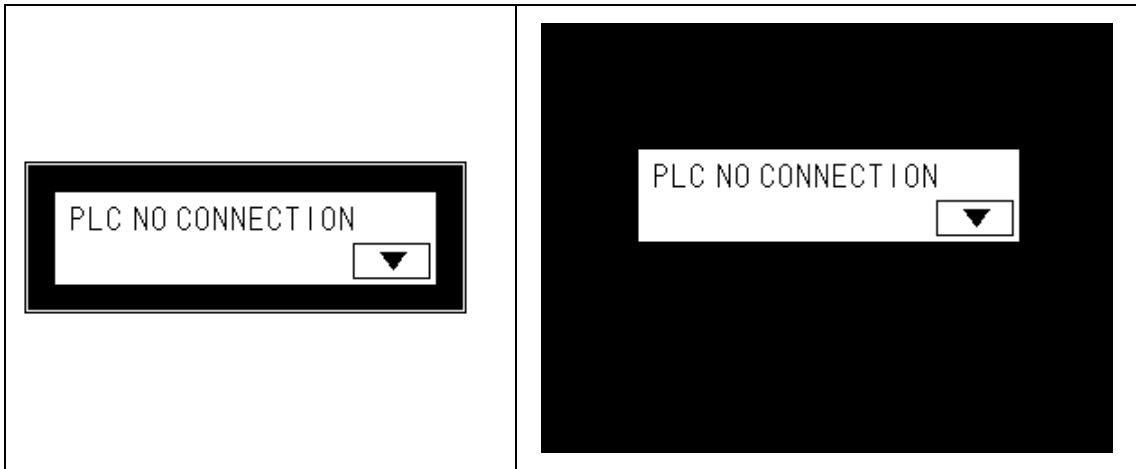

Touch 'CLOSE' and error message dialog box disappears. If connection error is not resolved after 5 seconds, error message appears again on the screen.



Caution

Connection error message appears only on user screen.

When the third (CH1), fourth (CH2) bit of system signal 1 device in system information device are ON status, error message for specified connect device appears on the screen.

For further details, refer to 'GP Editor user manual'.

8 System Window

8.1 Key pad type

No	Type	Key pad screen																																					
1	Binary	<table border="1"> <tr> <td colspan="4"></td> <td>CLR</td> </tr> <tr> <td colspan="4"></td> <td>▲</td> </tr> <tr> <td colspan="4"></td> <td>▼</td> </tr> <tr> <td>0</td> <td>1</td> <td>BS</td> <td>ENT</td> <td></td> </tr> </table>					CLR					▲					▼	0	1	BS	ENT																		
				CLR																																			
				▲																																			
				▼																																			
0	1	BS	ENT																																				
2	Octal	<table border="1"> <tr> <td colspan="4"></td> <td>CLR</td> </tr> <tr> <td>0</td> <td>1</td> <td>2</td> <td colspan="2">▲</td> </tr> <tr> <td>3</td> <td>4</td> <td>5</td> <td colspan="2">▼</td> </tr> <tr> <td>6</td> <td>7</td> <td>BS</td> <td>ENT</td> <td></td> </tr> </table>					CLR	0	1	2	▲		3	4	5	▼		6	7	BS	ENT																		
				CLR																																			
0	1	2	▲																																				
3	4	5	▼																																				
6	7	BS	ENT																																				
3	Decimal	<table border="1"> <tr> <td colspan="4"></td> <td>CLR</td> </tr> <tr> <td>0</td> <td>1</td> <td>2</td> <td>3</td> <td>▲</td> </tr> <tr> <td>4</td> <td>5</td> <td>6</td> <td>7</td> <td>▼</td> </tr> <tr> <td>8</td> <td>9</td> <td>-</td> <td>BS</td> <td>ENT</td> </tr> </table>					CLR	0	1	2	3	▲	4	5	6	7	▼	8	9	-	BS	ENT																	
				CLR																																			
0	1	2	3	▲																																			
4	5	6	7	▼																																			
8	9	-	BS	ENT																																			
4	Hexadecimal	<table border="1"> <tr> <td colspan="4"></td> <td>0</td> <td>1</td> <td>CLR</td> </tr> <tr> <td>2</td> <td>3</td> <td>4</td> <td>5</td> <td>6</td> <td colspan="2">▲</td> </tr> <tr> <td>7</td> <td>8</td> <td>9</td> <td>A</td> <td>B</td> <td colspan="2">▼</td> </tr> <tr> <td>C</td> <td>D</td> <td>E</td> <td>F</td> <td>BS</td> <td>ENT</td> <td></td> </tr> </table>					0	1	CLR	2	3	4	5	6	▲		7	8	9	A	B	▼		C	D	E	F	BS	ENT										
				0	1	CLR																																	
2	3	4	5	6	▲																																		
7	8	9	A	B	▼																																		
C	D	E	F	BS	ENT																																		
5	Real number	<table border="1"> <tr> <td colspan="5"></td> <td>CLR</td> </tr> <tr> <td>0</td> <td>1</td> <td>2</td> <td>3</td> <td>4</td> <td>▲</td> </tr> <tr> <td>5</td> <td>6</td> <td>7</td> <td>8</td> <td>9</td> <td>▼</td> </tr> <tr> <td>.</td> <td>EXP</td> <td>-</td> <td>BS</td> <td>ENT</td> <td></td> </tr> </table>						CLR	0	1	2	3	4	▲	5	6	7	8	9	▼	.	EXP	-	BS	ENT														
					CLR																																		
0	1	2	3	4	▲																																		
5	6	7	8	9	▼																																		
.	EXP	-	BS	ENT																																			
6	ASCII	<table border="1"> <tr> <td colspan="5"></td> <td>CLR</td> </tr> <tr> <td>S</td> <td>!</td> <td>"</td> <td>#</td> <td>\$</td> <td>%</td> <td>&</td> <td>'</td> <td>(</td> <td>)</td> <td>▲</td> </tr> <tr> <td>*</td> <td>+</td> <td>,</td> <td>-</td> <td>.</td> <td>/</td> <td>0</td> <td>1</td> <td>2</td> <td>3</td> <td>▼</td> </tr> <tr> <td>4</td> <td>5</td> <td>6</td> <td>7</td> <td>◀</td> <td>▶</td> <td>BS</td> <td>ENT</td> <td></td> </tr> </table>						CLR	S	!	"	#	\$	%	&	'	()	▲	*	+	,	-	.	/	0	1	2	3	▼	4	5	6	7	◀	▶	BS	ENT	
							CLR																																
		S	!	"	#	\$	%	&	'	()	▲																											
		*	+	,	-	.	/	0	1	2	3	▼																											
4	5	6	7	◀	▶	BS	ENT																																
<table border="1"> <tr> <td colspan="5"></td> <td>CLR</td> </tr> <tr> <td>P</td> <td>Q</td> <td>R</td> <td>S</td> <td>T</td> <td>U</td> <td>V</td> <td>W</td> <td>X</td> <td>Y</td> <td>▲</td> </tr> <tr> <td>Z</td> <td>[</td> <td>₩</td> <td>^</td> <td>_</td> <td>`</td> <td>a</td> <td>b</td> <td>c</td> <td>▼</td> </tr> <tr> <td>d</td> <td>e</td> <td>f</td> <td>g</td> <td>◀</td> <td>▶</td> <td>BS</td> <td>ENT</td> <td></td> </tr> </table>						CLR	P	Q	R	S	T	U	V	W	X	Y	▲	Z	[₩	^	_	`	a	b	c	▼	d	e	f	g	◀	▶	BS	ENT				
					CLR																																		
P	Q	R	S	T	U	V	W	X	Y	▲																													
Z	[₩	^	_	`	a	b	c	▼																														
d	e	f	g	◀	▶	BS	ENT																																
<table border="1"> <tr> <td colspan="5"></td> <td>CLR</td> </tr> <tr> <td>8</td> <td>9</td> <td>:</td> <td>;</td> <td><</td> <td>=</td> <td>></td> <td>?</td> <td>@</td> <td>A</td> <td>▲</td> </tr> <tr> <td>B</td> <td>C</td> <td>D</td> <td>E</td> <td>F</td> <td>G</td> <td>H</td> <td>I</td> <td>J</td> <td>K</td> <td>▼</td> </tr> <tr> <td>L</td> <td>M</td> <td>N</td> <td>O</td> <td>◀</td> <td>▶</td> <td>BS</td> <td>ENT</td> <td></td> </tr> </table>						CLR	8	9	:	;	<	=	>	?	@	A	▲	B	C	D	E	F	G	H	I	J	K	▼	L	M	N	O	◀	▶	BS	ENT			
					CLR																																		
8	9	:	;	<	=	>	?	@	A	▲																													
B	C	D	E	F	G	H	I	J	K	▼																													
L	M	N	O	◀	▶	BS	ENT																																
<table border="1"> <tr> <td colspan="5"></td> <td>CLR</td> </tr> <tr> <td>h</td> <td>i</td> <td>j</td> <td>k</td> <td>l</td> <td>m</td> <td>n</td> <td>o</td> <td>p</td> <td>q</td> <td>▲</td> </tr> <tr> <td>r</td> <td>s</td> <td>t</td> <td>u</td> <td>v</td> <td>w</td> <td>x</td> <td>y</td> <td>z</td> <td>{</td> <td>▼</td> </tr> <tr> <td> </td> <td>}</td> <td>~</td> <td>de</td> <td>◀</td> <td>▶</td> <td>BS</td> <td>ENT</td> <td></td> </tr> </table>						CLR	h	i	j	k	l	m	n	o	p	q	▲	r	s	t	u	v	w	x	y	z	{	▼		}	~	de	◀	▶	BS	ENT			
					CLR																																		
h	i	j	k	l	m	n	o	p	q	▲																													
r	s	t	u	v	w	x	y	z	{	▼																													
	}	~	de	◀	▶	BS	ENT																																

8.2 Key pad organization

										CLR
S	!	"	#	\$	%	&	'	()	▲
*	+	,	-	.	/	0	1	2	3	▼
4	5	6	7	←	→	BS	ENT			

KEY	Operation
ENT	Writes or inputs writing value on device.
CLR	Deletes all input value.
BS	Deletes latest input.
▲	Moves to the previous input field in accordance with configuration.
▼	Moves to the next input field in accordance with configuration.
◀*1	Moves to the previous page.
▶*1	Moves to the next page.

*1 Those keys are displayed only for ASCII input key pad.

ENT, CLR, ▲, ▼ key operation of user screen is according to 'Key Action' settings of 'Screen Auxiliary Configuration' dialog box.

Key operation	CLR	ENT	▲	▼
No movement	Holds keypad	Holds keypad	Not operated	Not operated
In order of user ID	Holds keypad	Holds keypad	Moves to previous input tag	Moves to next input tag
Hide cursor and key window	Closes keypad	Closes keypad	Moves to previous input tag	Moves to next input tag

9 Troubleshooting

This chapter is for possible errors in using GP, for diagnosis method by several errors and for troubleshooting.

9.1 Error and troubleshooting

No	Error description	Troubleshooting (Further details, refer to additional description)
1	There is error for writing, reading, or monitoring program	Troubleshooting in communication connection error

(1) Troubleshooting in communication connection error

Check as following list by number. If error is not solved, please notify this to our service center.

Check item	Error
Do you configure communication configuration (baudrate, data bit, stop bit, and parity) correctly?	
Is the specification and wiring of communication cable rated at our specification? ※1	

For connect GP, external device and PC, you must use the provided cable (sold separately).

10 Firmware update

You can update firmware periodically if necessary.

1st Firmware file is different as GP/LP model. Download a firmware file from www.autonics.com.

You can download only for same firmware GP/LP type with GP/LP type designated at GP Editor. Select [Common]-[GP/PLC Type] of menu, 'GP/PLC Type' dialog box appears. By pull-down menu, designate to be downloaded GP/LP type.

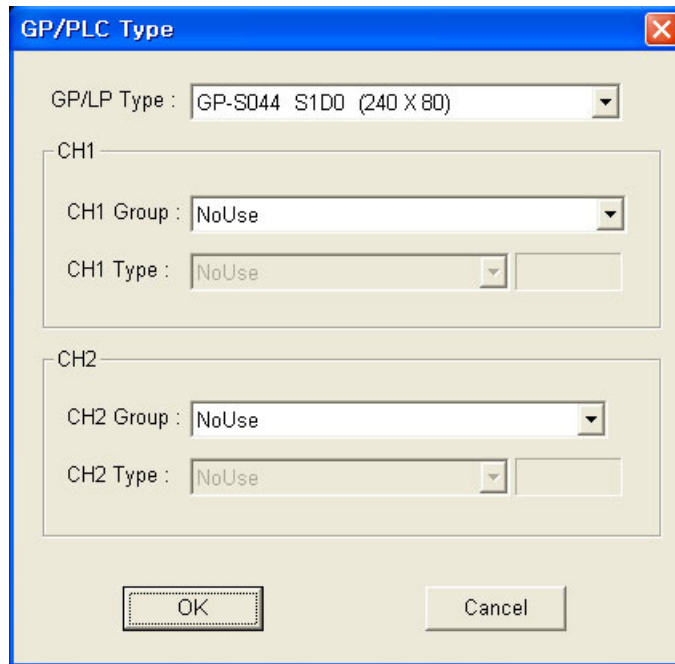

2nd Select [Communication]-[GP Firmware Download] of menu and 'GP Firmware Download' dialog box appears.

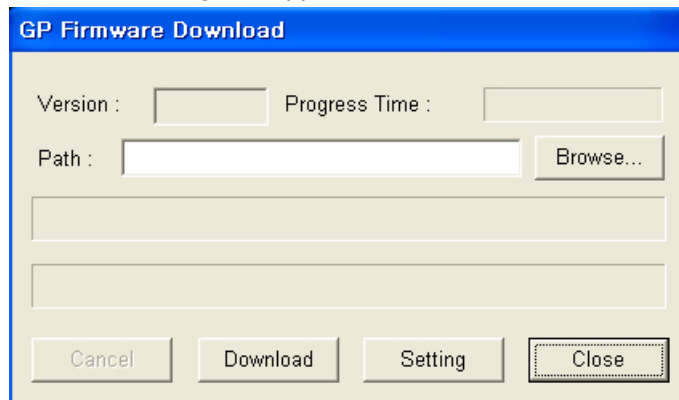

3rd Click 'Browse' and select firmware file to be downloaded.

- 4th Click 'Download' and the firmware information dialog box for current GP/LP firmware appears and asks whether to download or not. If connected GP/LP is not same as the designated GP/LP type from [Common]-[GP/PLC Type] of menu, error message appears.

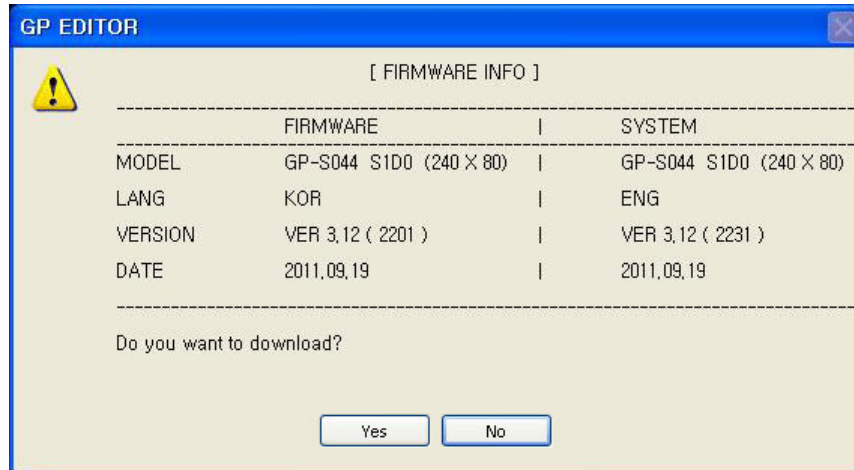

- 5th Click 'Yes' and GP/LP screen displays 'GP FIRMWARE UPGRADE' message. GP Editor displays 'GP Firmware Download' dialog box and download progresses.

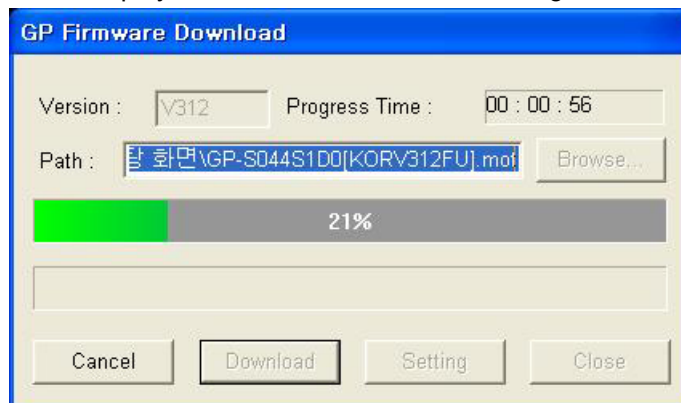

If you want to discontinue download, click 'Cancle' and 'Do you want to interrupt firmware download?' message appears. Click 'Yes' and it discontinues download. For discontinuing downloaod, re-start GP/LP.



- 6th When completing download successively, GP/LP displays 'UPGRADE OK PLEASE POWER OFF' message.
- 7th When failing donwload, GP/LP displays 'UPGRADE NG PLEASE POWER OFF' message. Re-start GP/LP. GP/LP maintains before firmware version and it does not affect to GP/LP operation.

Caution

Do not turn OFF GP power during firmware update.

11 Repair and Check

11.1 Change repair component

11.1.1 Battery replacement

Battery of GP is available for maintain user-defined setting, data backup of latch area, and time if there is unexpected power failure or it is not able to supply power. You need to change battery regularly.

(1) The status with discharged battery

- When time is not correct.
- After power failure, time is reset.
- After power failure, data of latch area is reset.

(2) Battery residual quantity display

You can check battery remaining from [SET ENVIRONMENT]-[BATTERY] of system setting menu in GP. Please replace battery if battery remaining is below 5%.

(3) Special register for battery

Current backup battery error [F0002C]	Turns ON when battery voltage is below than standard value
Maintain backup battery error [F0002D]	If current backup battery error turns ON at once, it maintains ON status before restarting GP.

11.2 Check

11.2.1 General check

The following table is for checking by every day/week.

Item	Description	Standard	Troubleshooting
Environment	Temperature	0 to 50°C	Adjust the ambient temperature
	Humidity	35 to 85%RH	Adjust the ambient humidity
	Vibration	No vibration	Establish vibration protection
Mounting status of GP	Check screw loosening for bracket	It should be mounted without a shaken.	Tight the screw.
Connection status of communication cable	Check screw loosening of connection cable	Cable connection part should be tightened.	Tight the screw. Use the standard cable

11.2.2 Periodic check

The following table is for checking by every month.

Item	Description	Standard	Troubleshooting
Power voltage	Measure power voltage	Within power voltage specification	Change supply power
Battery	Battery remaining status	Battery remaining 95%	Change battery
Waterproof rubber ring	Waterproof rubber ring status	Waterproof rubber ring should not be corroded.	Change waterproof rubber ring
Water leak and dusk proof	Water leak and dusk proof status	There is no water leaking, and no dust.	Establish water leak and dust protection
Inflammability gas	Leak inflammability gas	It should not be exposed at inflammability gas.	Establish leak inflammability gas protection



Caution

Caution for periodic check

- For checking power voltage, use the specified measuring device.
- If there are error elements, please write down the error and notify us with details.
- For changing the product, power must be turned OFF.
- For removing dust, foreign substance, use dry cloth without moist, or detergents.

Autonics

Sensors & Controllers

www.autonics.com

Distributor



Major Products

·Photoelectric Sensors·Fiber Optic Sensors·Door Sensors·Door Side Sensors·Area Sensors
·Proximity Sensors·Pressure Sensors·Connectors/Socket/Rotary Encoders·Panel Meters
·Counters·Timers·Temperature Controllers·SSRs/Power Controllers·Sensor Controllers
·Graphic/Logic Panels·Temperature/Humidity Transducers·Switching Mode Power Supplies
·Stepper Motors/Drivers/Motion Controllers·I/O Terminal Blocks & Cables·Display Units
·Control Switches/Lamps/Buzzers·Field Network Devices·Tachometer/Pulse(Rate) Meters
·Laser Marking System(Fiber, CO₂, Nd:YAG)·Laser Welding/Cutting System

■ Any proposal for a product improvement and development: Product@autonics.com

Corporate Headquarters

18 Bansong-ro, 513 Beon-gil, Haeundae-gu, Busan, South Korea 48002
Tel: 82-51-519-3232

■ Brazil – Autonics do Brasil Comercial Importadora Exportadora Ltda

Tel: 55-11-2307-8480 / Fax: 55-11-2309-7784 / E-mail: comercial@autonics.com.br

■ China – Autonics electronic(Jiaying) Corporation

Tel: 86-21-5422-5969 / Fax: 86-21-5422-5961 / E-mail: china@autonics.com

■ India – Autonics Automation India Private Limited

Tel: 91-22-2781-4305 / Fax: 91-22-2781-4518 / E-mail: india@autonics.com

■ Indonesia – PT. Autonics Indonesia

Tel: 62-21-8088-8814/5 / Fax: 62-21-8088-4442(4440) / E-mail: indonesia@autonics.com

■ Japan – Autonics Japan Corporation

Tel: 81-3-3950-3111 / Fax: 81-3-3950-3191 / E-mail: ja@autonics.com

■ Malaysia – Mal-Autonics Sensor Sdn. Bhd.

Tel: 60-3-7805-7190 / Fax: 60-3-7805-7193 / E-mail: malaysia@autonics.com

■ Mexico – Autonics Mexico S.A. DE C.V

Tel: 52-55-5207-0019 / Fax: 52-55-1663-0712 / E-mail: ventas@autonics.com

■ Russia – Autonics Corp. Russia Representative Office

Tel/Fax: 7-495-660-10-88 / E-mail: russia@autonics.com

■ Turkey – Autonics Otomasyon Ticaret Ltd. Sti.

Tel: 90-216-365-9117/3/4 / Fax: 90-216-365-9112 / E-mail: turkey@autonics.com

■ USA – Autonics USA, Inc.

Tel: 1-847-680-8160 / Fax: 1-847-680-8155 / E-mail: sales@autonicsusa.net

■ Vietnam – Cong Ty TNHH Autonics Vina

Tel: 84-8-3771-2662 / Fax: 84-8-3771-2663 / E-mail: vietnam@autonics.com