

LCD PID Temperature Controllers

TX Series

INSTRUCTION MANUAL

TCD220019AA	Autonics
-------------	-----------------

Thank you for choosing our Autonics product.

Read and understand the instruction manual and manual thoroughly before using the product.

For your safety, read and follow the below safety considerations before using.

For your safety, read and follow the considerations written in the instruction manual, other manuals and Autonics website.

Keep this instruction manual in a place where you can find easily.

The specifications, dimensions, etc are subject to change without notice for product improvement Some models may be discontinued without notice.

Follow Autonics website for the latest information.

Safety Considerations

- Observe all ‘Safety Considerations’ for safe and proper operation to avoid hazards.
- ⚠ symbol indicates caution due to special circumstances in which hazards may occur.

⚠ Warning Failure to follow instructions may result in serious injury or death

- Fail-safe device must be installed when using the unit with machinery that may cause serious injury or substantial economic loss.(e.g. nuclear power control, medical equipment, ships, vehicles, railways, aircraft, combustion apparatus, safety equipment, crime/disaster prevention devices, etc.)**
Failure to follow this instruction may result in personal injury, economic loss or fire.

- Do not use the unit in the place where flammable/explosive/corrosive gas, high humidity, direct sunlight, radiant heat, vibration, impact or salinity may be present.**

Failure to follow this instruction may result in explosion or fire.

- Install on a device panel to use.**

Failure to follow this instruction may result in fire or electric shock.

- Do not connect, repair, or inspect the unit while connected to a power source.**

Failure to follow this instruction may result in fire or electric shock.

- Check ‘Connections’ before wiring.**

Failure to follow this instruction may result in fire.

- Do not disassemble or modify the unit.**

Failure to follow this instruction may result in fire or electric shock.

⚠ Caution Failure to follow instructions may result in injury or product damage

- When connecting the power input and relay output, use AWG 20 (0.50 mm²) cable or over, and tighten the terminal screw with a tightening torque of 0.74 to 0.90 N m.**

When connecting the sensor input and communication cable without dedicated cable, use AWG 28 to 16 cable and tighten the terminal screw with a tightening torque of 0.74 to 0.90 N m.

Failure to follow this instruction may result in fire or malfunction due to contact failure.

- Use the unit within the rated specifications.**

Failure to follow this instruction may result in fire or product damage

- Use a dry cloth to clean the unit, and do not use water or organic solvent.**

Failure to follow this instruction may result in fire or electric shock.

- Keep the product away from metal chip, dust, and wire residue which flow into the unit.**

Failure to follow this instruction may result in fire or product damage.

Cautions during Use

- Follow instructions in ‘Cautions during Use’. Otherwise, it may cause unexpected accidents.
- Check the polarity of the terminals before wiring the temperature sensor. For RTD temperature sensor, wire it as 3-wire type, using cables in same thickness and length. For thermocouple (TC) temperature sensor, use the designated compensation wire for extending wire.
- Keep away from high voltage lines or power lines to prevent inductive noise. In case installing power line and input signal line closely, use line filter or varistor at power line and shielded wire at input signal line. Do not use near the equipment which generates strong magnetic force or high frequency noise.

- Do not apply excessive power when connecting or disconnecting the connectors of the product.

- Install a power switch or circuit breaker in the easily accessible place for supplying or disconnecting the power.

- Do not use the unit for other purpose (e.g. voltmeter, ammeter), but temperature controller.

- When changing the input sensor, turn off the power first before changing. After changing the input sensor, modify the value of the corresponding parameter.

- Do not overlapping communication line and power line. Use twisted pair wire for communication line and connect ferrite bead at each end of line to reduce the effect of external noise.

- Make a required space around the unit for radiation of heat. For accurate temperature measurement, warm up the unit over 20 min after turning on the power.

- Make sure that power supply voltage reaches to the rated voltage within 2 sec after supplying power.

- Do not wire to terminals which are not used.

- This unit may be used in the following environments.
 - Indoors (in the environment condition rated in ‘Specifications’)
 - Altitude Max. 2,000 m
 - Pollution degree 2
 - Installation category II

Ordering Information
This is only for reference, the actual product does not support all combinations. For selecting the specified model, follow the Autonics website .

T	X	4	①	-	②	4	③
----------	----------	----------	----------	----------	----------	----------	----------

- | | |
|-----------------------|---|
| ① Size | ③ Control output |
| S: DIN W 48 × H 48 mm | R: Relay |
| M: DIN W 72 × H 72 mm | S: SSR drive |
| H: DIN W 48 × H 96 mm | C: Selectable current or SSR drive output |
| L: DIN W 96 × H 96 mm | |

- | |
|--|
| ② Option in/output |
| 1: Alarm 1 |
| 2: Alarm 1 + Alarm 2 |
| A: Alarm 1 + Alarm 2 + PV transmission |
| B: Alarm output 1 + Alarm output 2 + RS485 communication |

Product Components

- Product
- Instruction manual
- Bracket

Manual

For proper use of the product, refer to the manuals and be sure to follow the safety considerations in the manuals.

Download the manuals from the Autonics website.

Software

Download the installation file and the manuals from the Autonics website.

■ DAQMaster

DAQMaster is comprehensive device management program. It is available for parameter setting, monitoring.

Sold Separately

- Terminal protection cover: RSA / RMA / RHA / RLA Cover

- Communication converter: SCM Series

Specifications			
Series	TX Series		
Power supply	100 - 240 VAC~ 50/60 Hz ±10%		
Power consumption	≤ 8 VA		
Sampling period	50 ms		
Input specification	Refer to 'Input Type and Using Range'.		
Control output	Relay	250 VAC~ 3 A, 30 VDC≒ 3 A, 1a	
	SSR	TX4S: 12 VDC≒ ±2 V, ≤ 20 mA TX4M/H/L: 13 VDC≒ ±3 V, ≤ 20 mA	
	Current	DC 4-20 mA or DC 0-20 mA (parameter), Load resistance: ≤ 500 Ω	
Alarm output	Relay	AL1/2: 250 VAC~ 3 A 1a	
Option output	PV transmission	DC 4 - 20 mA (Load resistance: ≤ 500 Ω, Output Accuracy: ±0.3% F.S.)	
	RS485 Comm.	Modbus RTU	
Display type	11 Segment (Red, Green, Yellow), LCD type		
Control type	Heating, Cooling	ON/OFF, P, PI, PD, PID Control	
	Heating&Cooling		
Hysteresis	1 to 100 (0.1 to 50.0) °C/°F		
Proportional band (P)	0.1 to 999.9 °C/°F		
Integral time (I)	0 to 9,999 sec		
Derivative time (D)	0 to 9,999 sec		
Control cycle (T)	0.5 to 120.0 sec		
Manual reset	0.0 to 100.0%		
Relay life cycle	Mechanical	≥ 5,000,000 operations	
	Electrical	≥ 200,000 operations (resistance load: 250 VAC~ 3 A)	
Dielectric strength	Between all terminals and case: 3,000 VAC~ 50/60 Hz for 1 min		
Vibration	0.75 mm amplitude at frequency 5 to 55Hz (for 1 min) in each X, Y, Z direction for 2 hours		
Insulation resistance	≥ 100 MΩ (500 VDC≒ megger)		
Noise immunity	±2 kV square shaped noise (pulse width 1 μs) by noise simulator R-phase, S-phase		
Memory retention	≈ 10 years (non-volatile semiconductor memory type)		
Ambient temperature	-10 to 50 °C, storage: -20 to 60 °C (no freezing or condensation)		
Ambient humidity	35 to 85%RH, storage: 35 to 85%RH (no freezing or condensation)		
Protection structure	IP50 (Front panel, IEC standards)		
Insulation type	Double or reinforced insulation (mark:  , dielectric strength between primary circuit and secondary circuit: 3 kV)		
Approval	CE , RoHS , FRL		
Unit weight (packaged)	• TX4S: ≈ 87 g (≈ 146 g)	• TX4M: ≈ 143 g (≈ 233 g)	
	• TX4H: ≈ 133 g (≈ 214 g)	• TX4L: ≈ 206 g (≈ 290 g)	

01) When using the unit at low temperature (below 0°C), display cycle is slow.

Communication Interface

■ RS485	
Comm. protocol	Modbus RTU
Application standard	EIA RS485 compliance with
Maximum connection	31 units (address: 01 to 127)
Synchronous method	Asynchronous
Comm. method	Two-wire half duplex
Comm. effective range	≤ 800 m
Comm. speed	2,400 / 4,800 / 9,600 (default) / 19,200 / 38,400 bps (parameter)
Response time	5 to 99 ms (default: 20 ms)
Start bit	1 bit (fixed)
Data bit	8 bit (fixed)
Parity bit	None (default), Odd, Even
Stop bit	1 bit, 2 bit (default)

Input Type and Using Range					
The setting range of some parameters is limited when using the decimal point display.					
Input type	Decimal point	Display	Using range (°C)	Using range (°F)	
Thermo-couple	K (CA)	1	<i>K E R H</i>	-50 to 1,200	-58 to 2,192
		0.1	<i>K E R L</i>	-50.0 to 999.9	-58.0 to 999.9
	J (IC)	1	<i>J I E H</i>	-30 to 800	-22 to 1,472
		0.1	<i>J I E L</i>	-30.0 to 800.0	-22.0 to 999.9
	L (IC)	1	<i>L I E H</i>	-40 to 800	-40 to 1,472
		0.1	<i>L I E L</i>	-40.0 to 800.0	-40.0 to 999.9
T (CC)	1	<i>E E C H</i>	-50 to 400	-58 to 752	
	0.1	<i>E E C L</i>	-50.0 to 400.0	-58.0 to 752.0	
	1	<i>R P R</i>	0 to 1,700	32 to 3,092	
	1	<i>S P R</i>	0 to 1,700	32 to 3,092	
	1	<i>E U S H</i>	-50 to 200	-58 to 392	
RTD	Cu50 Ω	1	<i>E U S L</i>	-50.0 to 200.0	-58.0 to 392.0
		0.1	<i>d P E H</i>	-100 to 400	-148 to 752
	DPt100 Ω	1	<i>d P E L</i>	-100.0 to 400.0	-148.0 to 752.0
		0.1			

■ Display accuracy		
Input type	Using temperature	Display accuracy
Thermocouple RTD	At room temperature (23°C ±5 °C)	(PV ±0.3% or ±1 °C higher one) ±1-digit <ul style="list-style-type: none">Thermocouple R, S below 200 °C: (PV ±0.5% or ±3 °C higher one) ±1-digit Over 200 °C: (PV ±0.5% or ±2°C higher one) ±1digit Thermocouple L, RTD Cu50 Ω: (PV ±0.5% or ±2 °C higher one) ±1-digit
	Out of room temperature range	(PV ±0.5% or ±2 °C higher one) ±1-digit <ul style="list-style-type: none">Thermocouple R, S: (PV ±1.0% or ±5 °C higher one) ±1digit Thermocouple L, RTD Cu50 Ω: (PV ±0.5% or ±3 °C higher one) ±1digit

Unit Descriptions

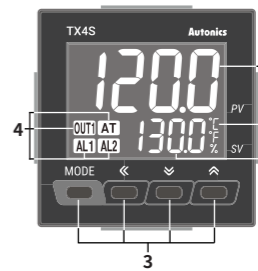

1. PV display part (White)

- Run mode: displays PV (Present value)

- Setting mode: displays parameter name

2. SV display part (Green)

- Run mode: displays SV (Setting value)
- Setting mode: displays parameter setting value

3. Input key	
Display	Name
[MODE]	Mode key
[◀], [▼], [▲]	Setting value control key

4. Indicator		
Display	Name	Description
°C, %, °F	Unit	Displays selected unit (parameter)
AT	Auto tuning	Flashes during auto tuning every 1 sec
OUT1	Control output	Turns ON when control output 1 is ON
AL1/2	Alarm output	Turns ON when each alarm output is ON

- PC loader port:** For connecting communication converter (sold separately).

Errors

Display	Description	Troubleshooting
<i>o P E n</i>	Flashes when input sensor is disconnected or sensor is not connected.	Check input sensor status.
<i>H H H H</i>	Flashes when PV is higher than input range.	When input is within the rated input range, this display disappears.
<i>L L L L</i>	Flashes when PV is lower than input range.	

Dimensions

- Unit: mm, For the detailed drawings, follow the Autonics website.
- Below is based on TX4S Series.

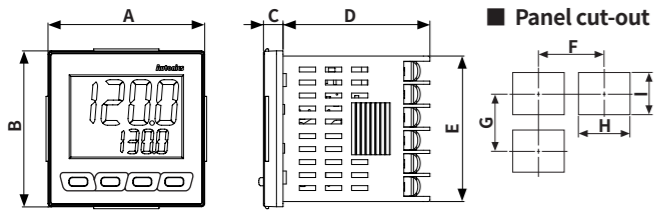

	Body					Panel cut-out			
	A	B	C	D	E	F	G	H	I
TX4S	48	48	6	45	44.8	≥ 65	≥ 65	45 ^{+0.6} ₀	45 ^{+0.6} ₀
TX4M	72	72	6	45	67.5	≥ 90	≥ 90	68 ^{+0.7} ₀	68 ^{+0.7} ₀
TX4H	48	96	6	45	91.5	≥ 65	≥ 115	45 ^{+0.6} ₀	92 ^{+0.8} ₀
TX4L	96	96	6	45	91.5	≥ 115	≥ 115	92 ^{+0.8} ₀	92 ^{+0.8} ₀

Bracket

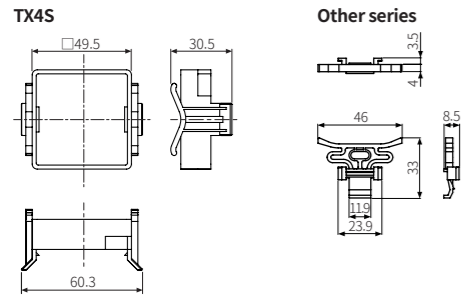

Installation Method

TX4S

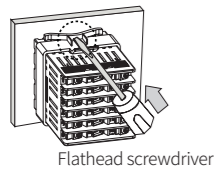

Other series

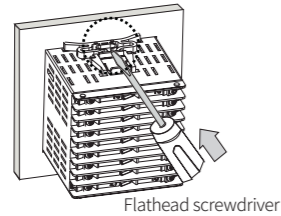

Insert the unit into a panel, fasten the bracket by pushing with tools with a flathead screwdriver.

Connections

- Shaded terminals are standard model.

TX4S

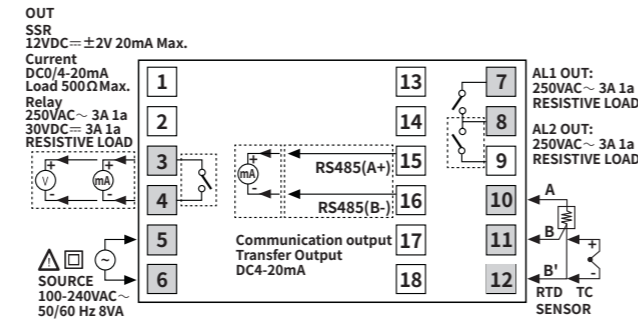

TX4M

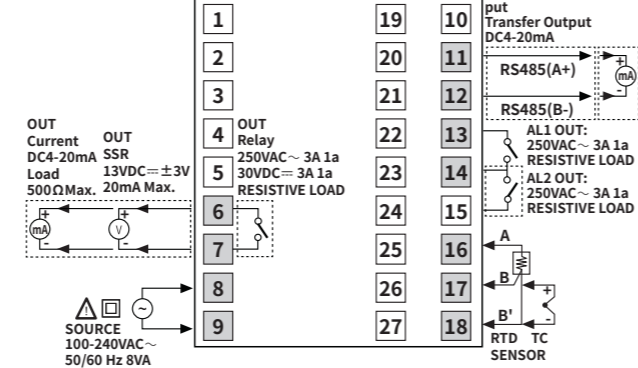

TX4H/L

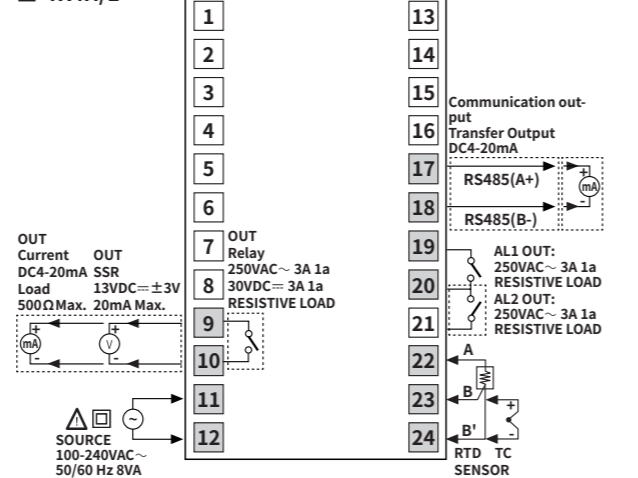

Crimp Terminal Specifications

- Unit: mm, Use the crimp terminal of follow shape.

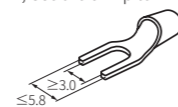

Fork crimp terminal

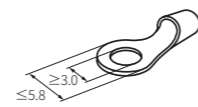

Round crimp terminal

Mode Setting

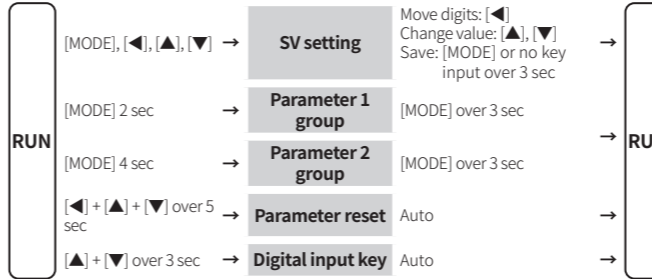

Parameter Setting

- Some parameters are activated/deactivated depending on the model or setting of other parameters. Refer to the descriptions of each item.
- [MODE] key: Move to next item after saving / Return to RUN mode after saving (≥ 3 sec) / Return to previous parameter after saving (within 1 sec returning to RUN mode)
- [◀] key: Select parameter / Move digits / Return to the upper level without saving (≥ 2 sec) / Return to RUN mode without saving (≥ 3 sec)
- [▲], [▼] key: Select parameter / Change setting value
- Return to the upper level without saving when there is no key input for more than 30 seconds.
- The range in parentheses '()' is the setting range when the set value of the 'input specification' parameter is used with one decimal point.
- Recommended parameter setting sequence: Parameter 2 group → Parameter 1 group → SV setting mode

Parameter 1 group

Parameter	Display	Default	Setting range	Condition
1-1 AL1 alarm temperature	RL 1	125.0	Deviation alarm: -F.S. to F.S. °C/°F Absolute value alarm: Within input range	2-16/19 AL1/2 alarm Operation: AM1 to AM6, HBA
1-2 AL2 alarm temperature	RL 2	125.0	[Alarm output2 model] Same as 1-1 AL1 alarm temperature	-
1-3 Auto tuning	RL	OFF	OFF: Stop, ON: Execution	-
1-4 Proportional band	P	10.0	0.1 to 999.9 °C/°F	2-8 Control type: PID
1-5 Integral time	I	24.0	0 (OFF) to 9,999 sec	-
1-6 Derivative time	d	4.9	0 (OFF) to 9,999 sec	-
1-7 Manual reset	RE 5 t	5.00	0.0 to 100.0%	2-8 Control type: PID & 1-5 Integral time: 0
1-8 Hysteresis	HY 5	2	1 to 100 (0.1 to 50.0) °C/°F	2-8 Control type: ONOF

Parameter 2 group

Parameter	Display	Default	Setting range	Condition
2-1 Input specification ⁽¹⁾	I N - t	t C R H	Refer to 'Input Type and Using Range'	-
2-2 Temperature unit ⁽²⁾	UNI t	°C	°C, °F	-
2-3 Input correction	I N - b	0	-999 to 999 (-199.9 to 999.9) °C/°F	-
2-4 Input digital filter	M F V F	0	0.1 to 120.0 sec	-
2-5 SV low limit ⁽²⁾	L - SV	-5.0	Within '2-1 Input specification: using range' L-SV ≤ H-SV - 1-digit °C/°F	-
2-6 SV high limit ⁽²⁾	H - SV	120.0	H-SV ≥ L-SV + 1-digit °C/°F	-
2-7 Control output mode	o - F t	HE R t	HEAT: Heating, COOL: Cooling	-
2-8 Control type ⁽³⁾	C - M d	P i d	PID, ONOF: ON/OFF	-
2-9 Control output	o U t	C U R P	[Selectable current or SSR drive output model] CURR: Current, SSR	-
2-10 SSR drive output type	S S R M	S t N d	[SSR drive output model] STND, CYCL, PHAS	-
2-11 Current output range	o M R	4 - 2 0	4-20: 4-20 mA, 0-20: 0-20 mA	2-9 Control output: CURR
2-12 Control cycle	t	2 0 0	0.5 to 120.0 sec	2-8 Control type: PID or 2-10 SSR drive output type: STND
2-13 AL1 alarm operation	RL - 1	RL 1 R	□□□ AM0: Off AM1: Deviation high limit alarm AM2: Deviation low limit alarm AM3: Deviation high, low limit alarm AM4: Deviation high, low reverse alarm AM5: Absolute value high limit alarm AM6: Absolute value low limit alarm SBA: Sensor break alarm LBA: Loop break alarm (LBA)	-
2-14 AL1 alarm option	RL - 1	RL 1 R	■ A: Standard alarm B: Alarm latch C: Standby D: Alarm latch and sequence 1 E: Standby F: Alarm latch and sequence 2 • Enter to option setting: Press [◀] key in 2-13 AL-1 alarm operation.	-
2-15 AL2 alarm operation	RL - 2	RL 1 R	[Alarm output2 model]	-
2-16 AL2 alarm option	RL - 2	RL 1 R	Same as '2-13/14 AL1 alarm operation/option'	-
2-17 Alarm output hysteresis	RL Y 5	1	1 to 100 (0.1 to 50.0) °C/°F	2-13/14 AL1/2 alarm operation: AM1 to 6
2-18 LBA time	L b RL t	0	0 (OFF) to 9,999 sec or auto ⁽⁴⁾	2-13/14 AL1/2 alarm operation: LBA
2-19 LBA band	L b RL b	2	0 (OFF) to 999 (0.0 to 999.9) °C/°F or auto ⁽⁵⁾	2-13/14 AL1/2 alarm operation: LBA & 2-18 LBA time: > 0
2-20 Transmission output low limit	F 5 - L	-5.0	[PV transmission output model] Refer to 'Input Type and Using Range'	-
2-21 Transmission output high limit	F 5 - H	120.0	-	-
2-22 Comm. address	R d P 5	1	[Communication output model] 1 to 127	-
2-23 Comm. speed	b P 5	96	[Communication output model] 24, 48, 96, 192, 384 (×100) bps	-
2-24 Comm. parity bit	P R t y	N o N E	[Communication output model] NONE, EVEN, ODD	-
2-25 Comm. stop bit	S t P	2	[Communication output model] 1, 2 bit	-
2-26 Response time	R S W t	2 0	[Communication output model] 5 to 99 ms	-
2-27 Comm. write	C o M W	E N R	[Communication output model] EN: Enable, DIS: Disable	-
2-28 Digital input key	d I - :	S t o P	STOP: Stop control output, AL, RE: Alarm reset, AT*: Execute auto tuning, OFF	*2-8 Control type: PID
2-29 Sensor error, MV	E R M V	0 0	0.0: OFF, 100.0: ON 0.0 to 100.0%	2-8 Control type: ONOF 2-8 Control type: PID
2-30 Lock	L o C	o F F	OFF LOC1: Lock parameter 2 group LOC2: Lock parameter 1/2 group LOC3: Lock parameter 1/2 group, SV setting	-

01) Below parameters are initialized when the setting value is changed.

- Parameter 1 group: AL1/2 alarm temperature,
- Parameter 2 group: Input correction, SV high/low limit, LBA band, Alarm output Hysteresis

02) If SV is lower/higher than low/high limit when the value is changed, SV is changed to the low/high limit value.

03) When changing the value from PID to ONOF, each value of following parameter is changed.
2-28 Digital input key: OFF, 2-29 Sensor error, MV: 0.0 (Setting value is lower than 100.0)

04) After auto tuning, the range is set as twice of the integral time automatically. If the previous setting value is outside of the range automatically set, it is set to the nearest Max. or Min. value of the range.

05) After auto tuning, the range is set as 10% of the proportion band automatically. If the previous setting value is outside of the range automatically set, it is set to the nearest Max. or Min value of the range.