



Operating Manual



Thank you very much for selecting our products.

1 Caution for your safety

Please read this instruction carefully before using this controller
 ※ The manual's information & specification can changeable to improve its quality without any notification.

Safety

1. As use this item after installing the duplex safety device in which is applied at dangerous factors such as serious human injury or serious damages of property & important machine because this item is not designed as safety device
2. Do not checking or repairing when it is power on
3. Please check the terminal number before connecting power supply
4. Do not disassembling or opening, remodeling, repairing without any permission

Safety Instruction and Hazard Warnings

- Please read the operating manual through completely before putting the device into operation.
- We will not assume any responsibility for damage to assets or persons caused by improper handling or failure to observe the safety instructions or hazard warnings.
- For safety and licensing reasons, unauthorized conversion and/or modification of the device is not permitted.
- Do not exceed the maximum permissible current - in case of higher loads, use a contactor of adequate power. Make sure that the supplied voltage matches the values specified for the instrument.
- The device must be adequately protected from water and dust as per the application and must be accessible via the use of appropriate tools
- The device must not be exposed to extreme temperature, sunlight, strong vibrations or high levels of humidity.
- Operation or installation is not permitted under unfavorable ambient conditions such as wetness or excessive induction loads or solenoid and dust, combustible gases, vapors or solvents, especially high-frequency noise
- Avoid operation or installation close to high-frequency fields such as welding devices, sewing machines, wireless transmitter, radio systems, SCR controller, etc
- Do not install the sensor cable nearby signal cable, power cable, load cable
- Please use the shield cable when the sensor cable's lengthen, however do not make it too much longer
- Please use the sensor cable without any cutting or flaw, blemish.
- The device is not a toy and should be kept away from children
- Installation work must only be carried out by suitably qualified personnel who are familiar with the hazards involved and with the relevant regulations.
- You shouldn't tinker with anything or the product may not be opened or disassembled unless you know what you're doing. Please ask us about this questioning

Danger

Attention ! Never work on electrical connections when the machine is switched on

2 Composition

model	sensor	temp./humi.range	external size	function
FOX-301A-1	HCPV-220NH	-40.0 ~ 65.0°C 10 ~ 95%	W72 X H72mm	temp. control
FOX-301AR1				humi. control
FOX-301JB-1			W193.5 X H241mm	temp. control
FOX-301JR1				humi. control
FOX-301JSH	SH-104	0.0%~100.0%Rh	W94 X H150mm	temp. control
FOX-8301-1	HCPV-220NH	-40.0 ~ 65.0°C 10 ~ 95%	W94 X H150mm	temp. control
FOX-8301R1				humi. control

*HCPV-220NH can be replaced with FS-200N(-55.0°C~99.9°C) and HCPV-220(10~95%).

3 Part name

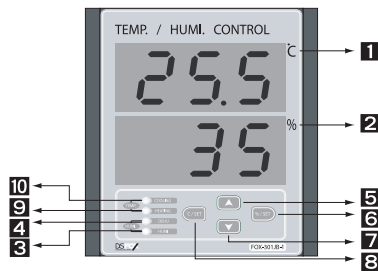
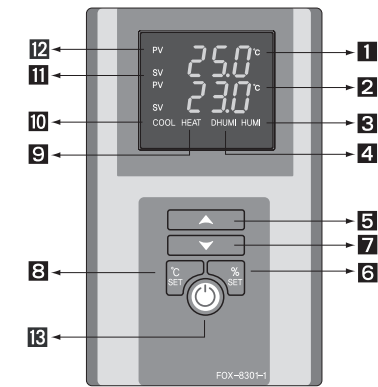
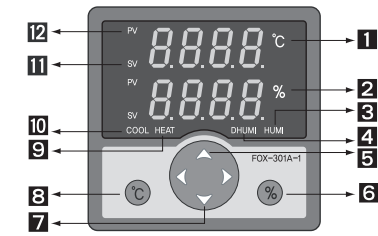

- 1: Display of the present temperature (red color)
- 2: Display of the present humidity (green color)
- 3: Output display of the humidity's working
- 4: Output display of the dehumidity's working
- 5: Up
- 6: Humidity mode
- 7: Down
- 8: Temperature mode
- 9: Display of the heating output
- 10: Display of the cooling output
- 11: Display of the measuring value
- 12: Display of the set value
- 13: Power supply

4 Connection

output : 250VAC 2A
 Please make use of the power relay or a suitable magnet surely.

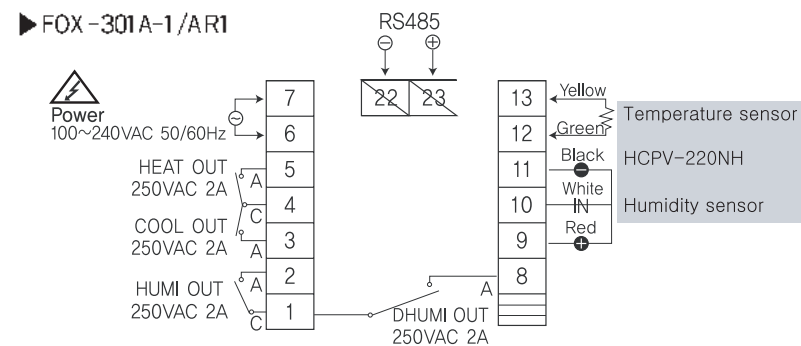

FOX-301JB-1/JR1

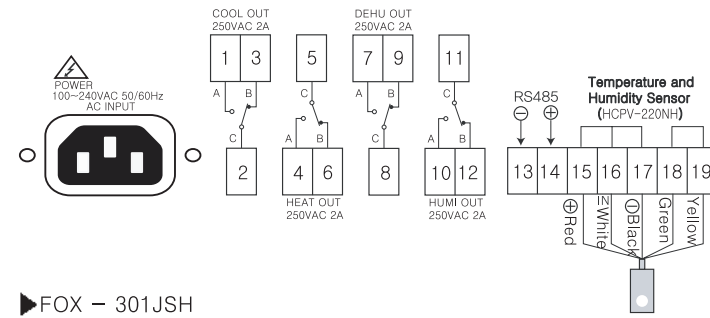

FOX-301JSH

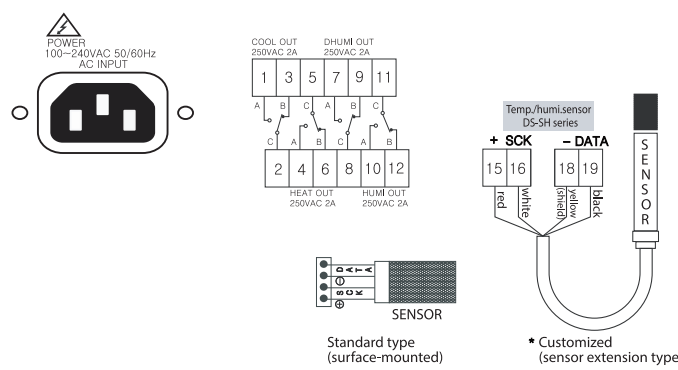

FOX-8301-1/R1

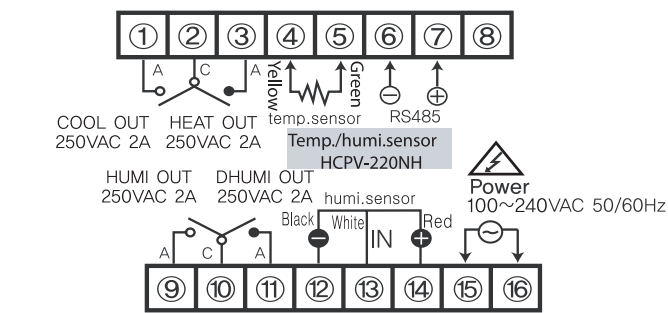

5 Size & Dimension

FOX-301A-1/AR1 (72x72x110mm)

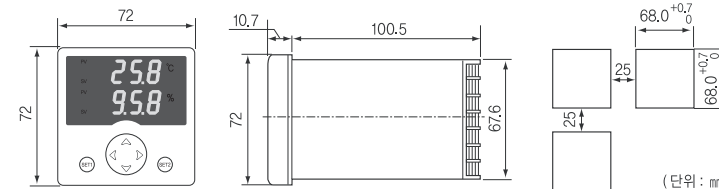

FOX-301JB-1/JSH (193.5x241x57mm)

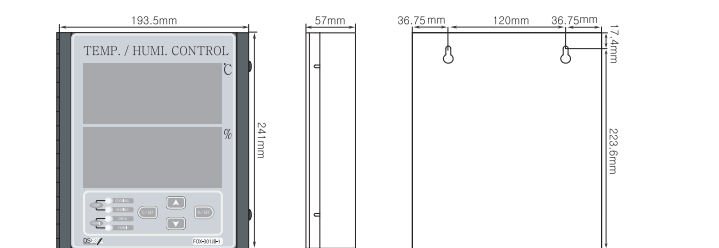

FOX-8301-1/R1 (94x150x39mm)

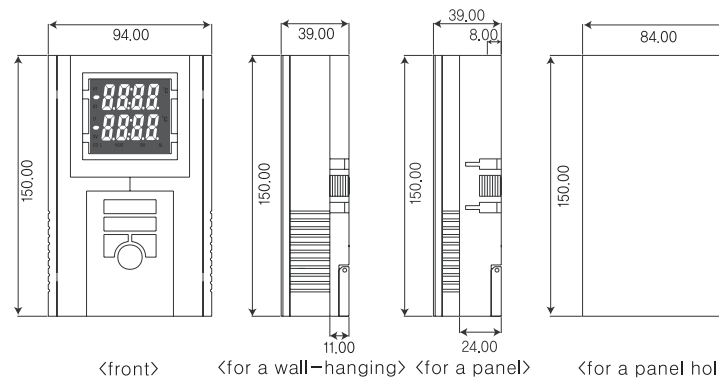

6 Temperature

Setting for the temperature

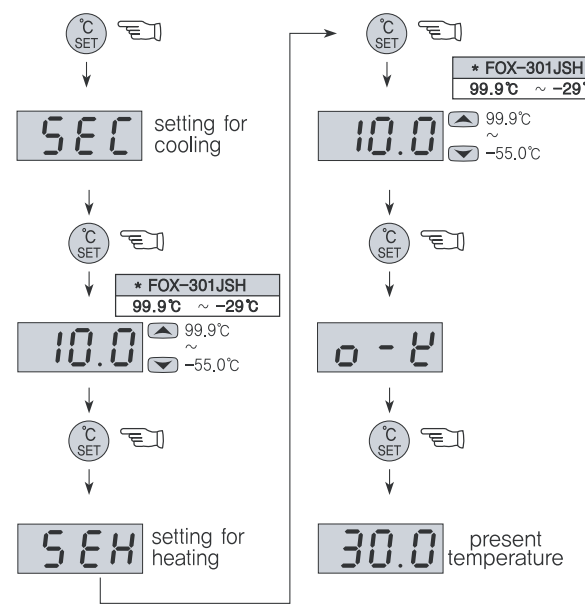

Setting for temperature programs

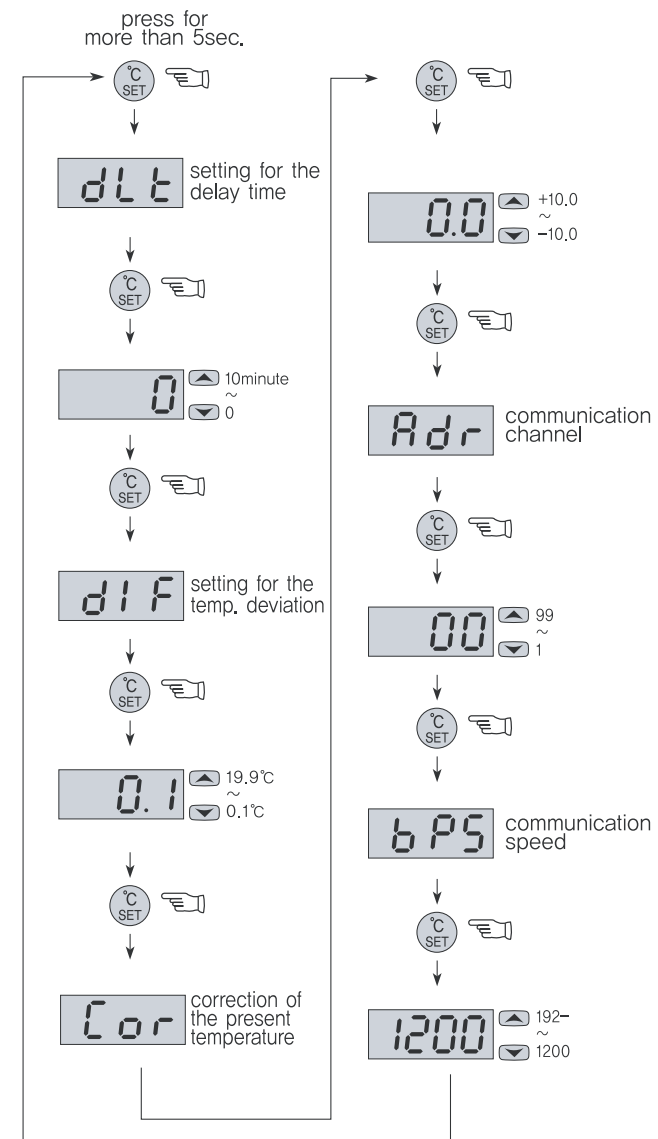

7 Humidity

Setting for the humidity

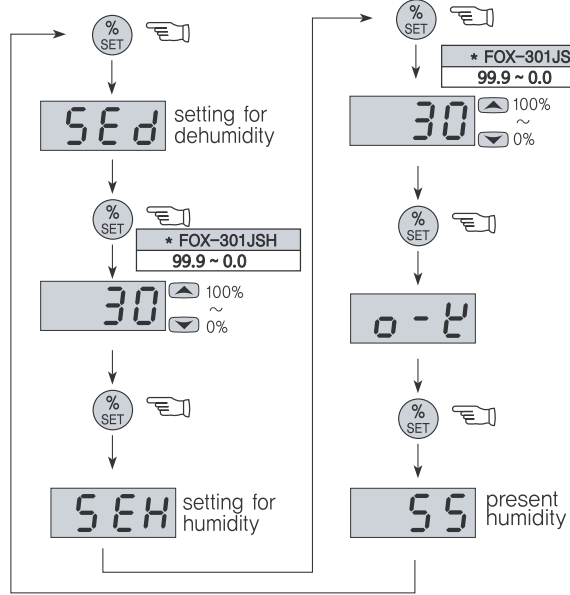

Setting for humidity programs

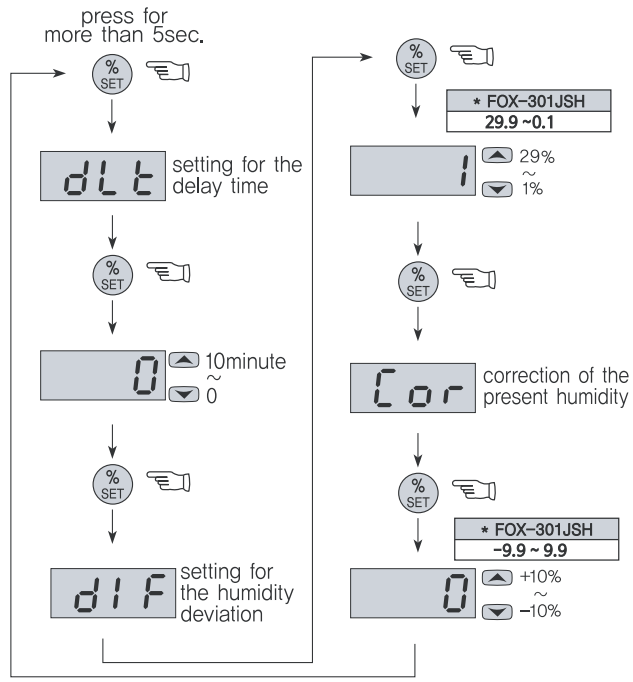

※To change it with program mode, press the --key for more than 5 second in the present temperature display mode.

※The set or programming mode is terminated, if you press the --key, parameters(set values) are saved after the display shows OK letter or return to present temperature automatically after 30 second.

8 Detailed manual

1. dIF : Setting for temperature deviation

- In the ON/OFF control, it needs at regular interval between ON and OFF.
- By operating the ON/OFF control frequently, the relay or its output contact can be damaged quickly and it also occurs the hunting(oscillating, chattering) by virtue of external noise. You can make use of the temperature deviation in order to protect its relay or contact and so on.

「ex=> The method of the temp. deviation when ON/OFF control」

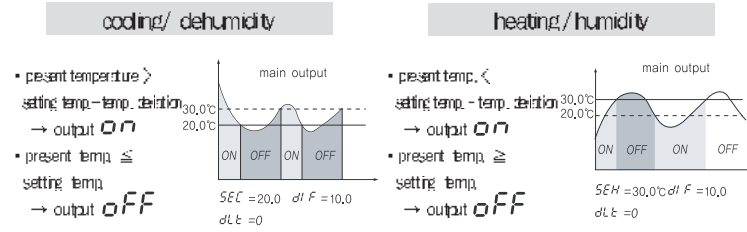

2. dLt : Delay time of the output

It is widely used as the followings

- in case of operating the ON/OFF control very often,
- to protect the operation machinery when re-input of the power supply or momentary stoppage of power supply

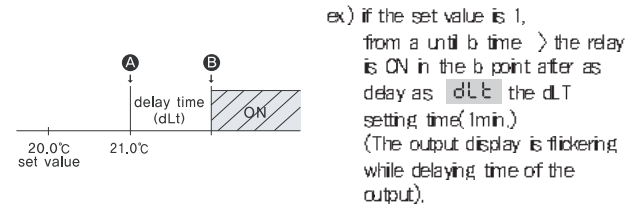

ex) if the set value is 1, from a until b time > the relay is ON in the b point after as delay as dLt the dLT setting time(1min.) (The output display is flickering while delaying time of the output).

3. Cor : Correction of the present temperature.

- It is used for the correction of a discrepancy between the display temperature and real temperature

ex) real temp. : 10.0°C
display : 12.0°C → Cor : 0.0 ⇒ -2.0 correction
→ 10.0°C display (corrected present temperature)

4. Adr : Communication channel

- To designate the channel 1~99 while RS485 communication working

5. bPS : Communication speed(velocity)

- 120, 1200 : 1200bps
- 240, 2400 : 2400bps
- 480, 4800 : 4800bps
- 960, 9600 : 9600bps
- 192, 1920 : 19200bps

(Start bit 1, Stop bit 1, Non parity)

9 Temp.range & set value when deliver

	function	display	range	set value	remarks
setting Temp.	setting for cooling	SEd	-55.0~99.9	10.0	
	setting for heating	SEH	-55.0~99.9	10.0	
setting programs	temperature deviation	dIF	0.1~19.9	1.0	
	delay time	dLt	0~10	0	minute
	correction of the temperature	Cor	-10.0~10.0	0.0	correct for a discrepancy between the display temp. and an actual temperature.
	Communication channel	Adr	01~99	0	RS485communication
	Communication speed	bPS	1200/2400/4800/9600/19200	1200	RS485 communication

10 Humi. range & set value when deliver

	function	display	range	set value	remarks
setting humi.	setting for dehumidify	SEd	0~100%	30%	
	setting for humidity	SEH	0~100%	30%	
setting programs	humidity deviation	dIF	1~29	1	
	delay time	dLt	0~10	0	minute
	correction of the humidity.	Cor	-10~10	0	correct for a discrepancy between the display humi. and an actual humidity.

11 Communication output

Interface

specification	in conformity EIA RS485
maximum connection	32(However, available to set the Address from 01 until 99)
the method of communication	two-wire half-duplex operation
synchronous system	asynchronous system
communication distance	within 1,2km
communication speed	1200/2400/4800/9600/19200bps(assess to section)
Start bit	fixed 1bit
Stop bit	fixed 1bit
Parity bit	none
Data bit	fixed 8bit
Protocol	BCC

System

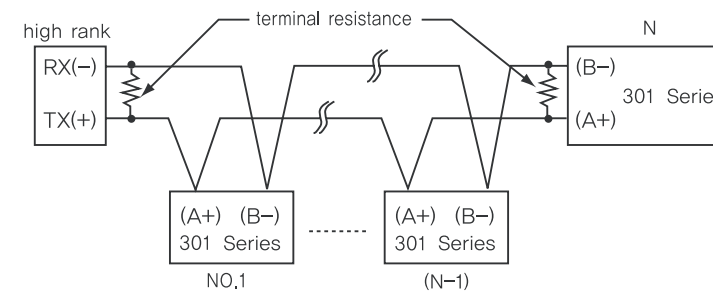

Definition between communication command and Block

Show the Format of the Command

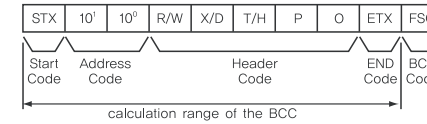

Show the Format of the Response

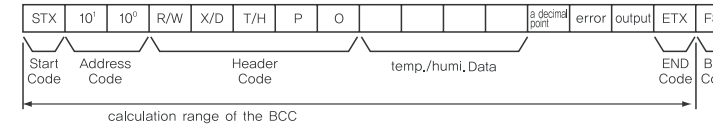

① Start Code

show the lead(head) of the Block
STX->[02H], ACK will be added in case of Response.

② Address Code

A high rank system can discriminate the channel code number among FOX-301series
It is available to set between 01 and 99(BCD ASC II)

③ Header Code

show the command name as an alphabetic letter
RX(reading demand) → R[52H], X[58H]
RD(reading response) → R[52H], D[44H]
WX(writing demand) → W[57H], X[58H]

WD(writing response) → W[57H], D[44H]

TPO(temperature measuring value) → W[54H], P[50], O[30H]
HPO(temperature measuring value) → H[48H], P[50], O[30H]

- Composition of Data
Data is displayed as "Hexadecimal"
- Decimal point → O[30H] there is no "decimal point"
1[31H] there is "decimal point"
- Error → O[30H] there is no "error"
1[31] interrupted of the sensor's cable
2[32] short-circuited error of the sensor

	TEMP		HUMI	
	COOL	HEAT	HUMI	DHUMI
0(30H)	O	O	0(30H)	O
1(31H)	O	X	1(31H)	X
2(32H)	X	O	2(32H)	O
3(33H)	X	X	3(33H)	X

⑧ END Code

show the end(close) of the Block ETX → [03H]

⑨ BCC

show the XOR arithmetic and logic values from the start(STX) to the ETX

• the others : As of no response of the ACK

- in case of not equivalent to the channel after receiving STX
 - in case of generating the Receive Buffer Overflow
 - in case of not equivalent to the communication's set values or baud rate
- treatment- in case of no response of the ACK
- check the cable
 - check the communication's condition (set values)
 - if the main cause of the status is the noise, try to do communication practicing 3times until recovering normally.
 - change the communication speed in case of bring about the communication's error frequently.

12 Error message

- E r I Memory error. Turn the power off and turn it on again
If the error message persists, please request us A/S by return
- O - E Sensor error. The sensor is interrupted. Check the cable.
- S - E Sensor error. The sensor is short-circuited. Check the cable

※ The product's specification can be changed without any notification to improve its quality.

■ H.Office : Ballyonsandan 1-ro, Jangan-eup, Gijang, Busan, Republic of Korea

■ Factory : Ballyonsandan 1-ro, Jangan-eup, Gijang, Busan, Republic of Korea

■ Tel : +82 (051) 819-0425~7

■ FAX : 82-51-819-4562

■ E-mail : conotec@conotec.co.kr

■ Homepage : www.conotec.co.kr

- Main Products & Development
 - Digital Temperature /Humidity Controller
 - Digital Timer, Current/Voltage Meter
 - Other Products Development