

Motor Control Timers

- Single phase Motor Restart Control Timer with Memory Time
- Under Voltage Trip and ON Delay



Ordering Information

Cat. No.	Description
22LDT0	240 VAC, Motor Restart Control Timer, 1 C/O
23LDT0	110 VAC, Motor Restart Control Timer, 1 C/O

UL Approval not applicable for Cat No. 23LDT0

Motor Control Timers



Cat. No.	22LDT0	23LDT0
Parameters		
Timer Description	Motor Restart Control Timer	
Functional Diagram	<p style="text-align: center;">t: Power Fail Time; Td: Delay Time; Tm: Memory Time</p>	
Supply Voltage (ϕ)	240 VAC	110 VAC
Supply Variation	- 20% to +10% (of ϕ)	
Frequency	50/60 Hz	
Power Consumption (Max.)	4 VA	
Timing Ranges	Memory Time (Tm): 0.2 to 6s, Delay Time (Td): 0.2 to 60s	
Trip Voltage	176 VAC, (\pm 6VAC)	80 VAC, (\pm 6VAC)
Hysteresis	4 VAC to 10 VAC	
Reset Time	200 ms (Max.)	
Setting Accuracy	\pm 5% of Full scale	
Repeat Accuracy	\pm 1%	
Output	Relay Output	1 C/O
	Contact Rating	5A @ 240 VAC / 28 VDC (Resistive)
	Electrical Life	1×10^5
	Mechanical Life	1×10^7
Utilization Category	AC - 15	Rated Voltage (Ue): 120/240 V, Rated Current (Ie): 3.0/1.5 A
	DC - 13	Rated Voltage (Ue): 24/125/250 V, Rated Current (Ie): 2.0/0.22/0.1 A
Operating Temperature	-15°C to +60°C	
Storage Temperature	-20°C to +70°C	
Humidity (Non Condensing)	95% (Rh)	
LED Indication	Green LED \rightarrow Power ON, Red LED \rightarrow Relay ON	
Enclosure	Flame Retardant UL94-V0	
Dimension (W x H x D) (in mm)	22.5 X 75 X 100.5	
Weight (unpacked)	130 g	
Mounting	Base / DIN Rail	
Certification		
Degree of Protection	IP 20 for Terminals, IP 40 for Enclosure	

EMI / EMC

Harmonic Current Emissions	IEC 61000-3-2
ESD	IEC 61000-4-2
Radiated Susceptibility	IEC 61000-4-3
Electrical Fast Transients	IEC 61000-4-4
Surges	IEC 61000-4-5
Conducted Susceptibility	IEC 61000-4-6
Voltage Dips & Interruptions (AC)	IEC 61000-4-11
Conducted Emission	CISPR 14-1
Radiated Emission	CISPR 14-1

Environmental

Cold Heat	IEC 60068-2-1
Dry Heat	IEC 60068-2-2
Vibration	IEC 60068-2-6
Repetitive Shock	IEC 60068-2-27
Non-Repetitive Shock	IEC 60068-2-27

WORKING

The timer is used for instantaneous or delayed motor startup after a short-time power failure (max. 6 sec). The start occurs immediately if power supply is disrupted for less than 0.2 sec. If the power failure lasts longer, the relay activates its memory for a time that can be set to 0.2 to 6 sec, after which no automatic restart is possible. If power supply is restored while the memory period is elapsing, the relay commands a motor restart with a delay time from power supply restoration that can be set to 0.2 to 60 sec. A system stop cancels the memory function after 50 ms, and therefore the stop signal should be on for at least this time. The relay is non-sensitive to any control voltage fluctuation or disruption during or after the motor stop.

Motor Control Timers

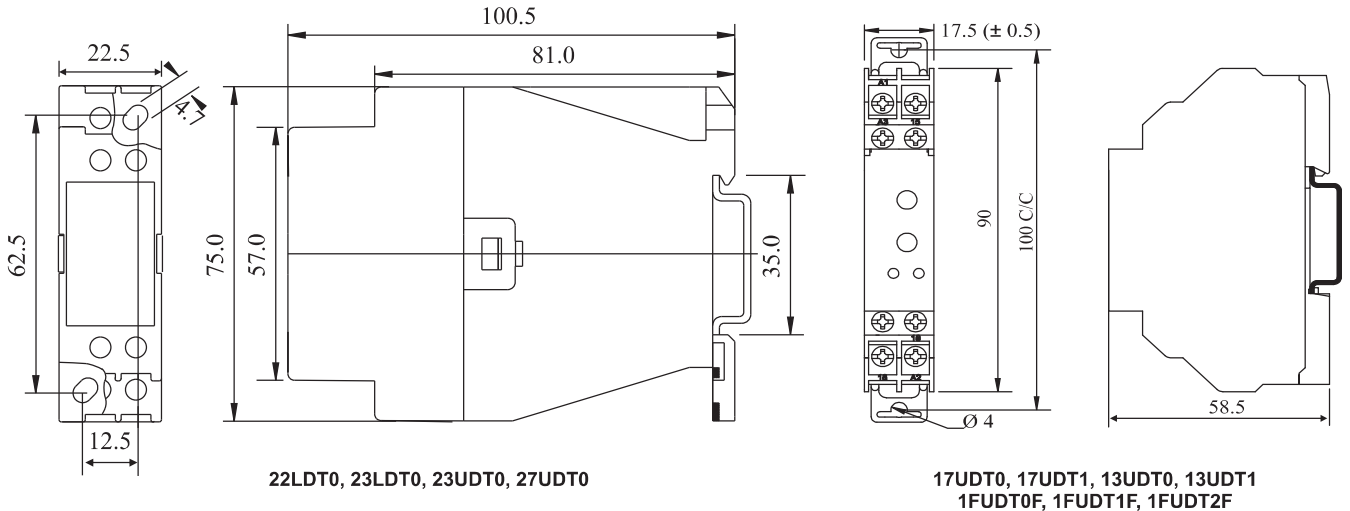

MOUNTING DIMENSION (mm)



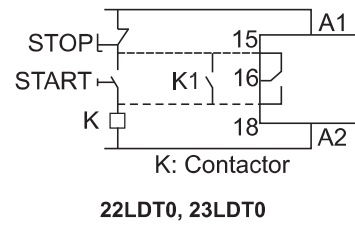
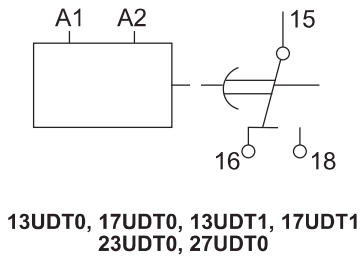

CONNECTION DIAGRAM

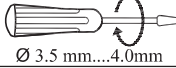

TERMINAL TORQUE & TERMINAL CAPACITY

 Ø 3.5 mm...4.0mm	0.60 N.m (6 Lb.in)
	1 x 4.0 mm ² Solid/Stranded Wire
AWG	1 x 20 to 10

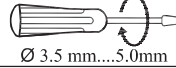
22LDT0, 23LDT0, 23UDT0, 27UDT0

 Ø 3.5 mm...5.0mm	0.80 N.m (7.1 Lb.in)
	2 x 2.5 mm ² Solid/Stranded Wire
AWG	2 x 20 to 14

13UDT0, 17UDT0, 13UDT1, 17UDT1