

TeSys

Motor control and protection components

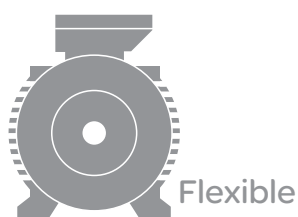

Motor starters **M**



Smart Circuit breakers

Protection Contactors

Thermal overload relays

Fuse switch-disconnectors

Reliable

Motor controllers



Thermal overload relays - For use with TeSys K contactors		
Type of product	Range	Pages
Adjustable thermal overload relays For motors TeSys LRK	From 0.16 to 16 A	B11/2
Adjustable thermal overload relays For unbalanced loads TeSys LRK	From 0.8 to 16 A	B11/3
Thermal overload relays Class 10 - For use with TeSys D contactors		
Adjustable thermal overload relays For motors TeSys LRD	From 0.16 to 140 A	B11/4
Adjustable thermal overload relays For unbalanced loads TeSys LRD	From 0.16 to 140 A	B11/4
Thermal overload relays Class 20 - For use with TeSys D contactors		
Adjustable thermal overload relays For motors TeSys LRD	From 0.63 to 80 A	B11/6
Adjustable thermal overload relays For unbalanced loads TeSys LRD	From 0.63 to 32 A	B11/6
Electronic thermal overload relays - For use with TeSys F contactors		
Compensated and differential overload relays, with or without alarm TeSys LR9F	From 50 to 630 A	B11/10
Single pole magnetic over current relays		
Latching or non latching overload relays TeSys RM1	From 1.15 to 630 A	B11/14
Thermistor-type protection units - For use detection of motor overheating		
Protection units and PTC probes, with or without fault memory protection units TeSys LT3	From 90 to 170 °C	B11/16
Electronic over current relays - For machine protection or machine protection		
Predefined or adjustable starting times, Manual reset	From 1.5 to 34 A	B11/18
Manual reset, manual and electric reset	From 0.5 to 50 A	B11/18

Protection components

TeSys LRK thermal overload relays, adjustable from 0.11 to 16 A

Overload relays

3-pole relays with screw clamp terminals

These overload relays are designed for the protection of motors. They are compensated and phase failure sensitive. Resetting can either be manual or automatic.

Direct mounting: under the contactor for versions with screw clamp terminals only; pre-wired terminals, see pages B11/26 and B11/28.

Separate mounting: using terminal block LA7 K0064 (see below).

On the front face of the overload relay:

- selection of reset mode: Manual (marked H) or Automatic (marked A),
- red pushbutton: Trip Test function,
- blue pushbutton: Stop and manual Reset,
- yellow trip flag indicator: overload relay tripped.

Protection by magnetic circuit breaker GV2 LE, see pages A5/11 and A5/20.

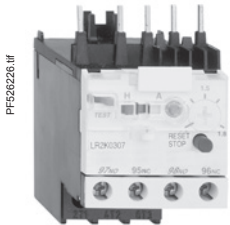

LR2 K0307

Class 10 A (the standard specifies a tripping time of between 2 and 10 seconds at 7.2 In)

Relay setting range	Fuses to be used with selected relay			Reference
	Maximum rating			
	Type			
	aM	gG	BS88	
A	A	A	A	
0.11...0.16	0.25	0.5	–	LR2K0301
0.16...0.23	0.25	0.5	–	LR2K0302
0.23...0.36	0.5	1	–	LR2K0303
0.36...0.54	1	1.6	–	LR2K0304
0.54...0.8	1	2	–	LR2K0305
0.8...1.2	2	4	6	LR2K0306
1.2...1.8	2	6	6	LR2K0307
1.8...2.6	4	8	10	LR2K0308
2.6...3.7	4	10	16	LR2K0310
3.7...5.5	6	16	16	LR2K0312
5.5...8	8	20	20	LR2K0314
8...11.5	10	25	20	LR2K0316
10...14	16	32	25	LR2K0321
12...16	20	40	32	LR2K0322

Protection components

TeSys LRK thermal overload relays, adjustable from 0.11 to 16 A

Overload relays

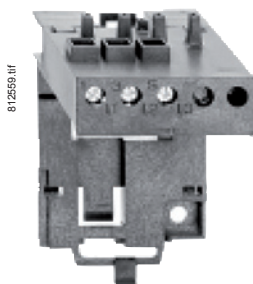

LA7 K0064

Overload relays for unbalanced loads

Class 10 A: to order, replace the prefix **LR2** by **LR7** in the references selected from above (only applicable to overload relays **LR2 K0305** to **LR2 K0322**).
Example: **LR7 K0308**.

Accessory

Description	Type of connection	Reference
Terminal block for separate clip-on mounting of the overload relay on 35 mm rail	Screw clamp	LA7K0064

Protection components

3-pole electronic thermal overload relays, TeSys LR9 F for motor protection

Compensated and differential overload relays

Thermal overload relays:

- compensated and differential,
- with relay trip indicator,
- for a.c.,
- for direct mounting on contactor or independent mounting ⁽¹⁾.



LR9 F53●●



LR9 F73●●

Relay setting range	Fuses to be used with selected relay		For direct mounting beneath contactor LC1	Reference	Weight
	aM	gG			
A	A	A			kg
Class 10 ⁽²⁾					
30...50	50	80	F115...F185	LR9F5357	0.885
48...80	80	125	F115...F185	LR9F5363	0.900
60...100	100	200	F115...F185	LR9F5367	0.900
90...150	160	250	F115...F185	LR9F5369	0.885
132...220	250	315	F185...F400	LR9F5371	0.950
200...330	400	500	F225...F500	LR9F7375	2.320
300...500	500	800	F225...F500	LR9F7379	2.320
380...630	630	800	F400...F630 and F800	LR9F7381	4.160
Class 20 ⁽²⁾					
30...50	50	80	F115...F185	LR9F5557	0.885
48...80	80	125	F115...F185	LR9F5563	0.900
60...100	100	200	F115...F185	LR9F5567	0.900
90...150	160	250	F115...F185	LR9F5569	0.885
132...220	250	315	F185...F400	LR9F5571	0.950
200...330	400	500	F225...F500	LR9F7575	2.320
300...500	500	800	F225...F500	LR9F7579	2.320
380...630	630	800	F400...F630 and F800	LR9F7581	4.160

⁽¹⁾ When mounting overload relays up to size **LR9 F5371** directly beneath the contactor, they may be additionally supported by a mounting plate (see page B11/13). Above this size it is always necessary to use the mounting plate.

Power terminals can be protected against direct finger contact by the addition of shrouds and/or insulated terminal blocks, to be ordered separately (see page B11/13).

⁽²⁾ Standard IEC 60947-4 specifies a tripping time for 7.2 times the setting current I_n :

- class 10: between 4 and 10 seconds,
- class 20: between 6 and 20 seconds.

Protection components

3-pole electronic thermal overload relays, TeSys LR9 F for motor protection

Compensated overload relays, class 10 or 20 with alarm

Thermal overload relays:

- compensated,
- with relay trip indicator,
- for a.c.,
- for direct mounting on contactor or independent mounting ⁽¹⁾,
- class 10 or 20 by selector switch,
- protection of 3-phase or single-phase circuits by selector switch,
- with alarm function that enables tripping to be forestalled.



LR9 F57

Relay setting range	Fuses to be used with selected relay		For direct mounting beneath contactor LC1	Reference	Weight
	aM	gG			
A	A	A			kg
30...50	50	80	F115...F185	LR9F57	0.885
48...80	80	125	F115...F185	LR9F63	0.900
60...100	100	200	F115...F185	LR9F67	0.900
90...150	160	250	F115...F185	LR9F69	0.885
132...220	250	315	F185...F400	LR9F71	0.950
200...330	400	500	F225...F500	LR9F75	2.320
300...500	500	800	F225...F500	LR9F79	2.320
380...630	630	800	F400...F630 and F800	LR9F81	4.160

⁽¹⁾ When mounting overload relays up to size **LR9 F71** directly beneath the contactor, they may be additionally supported by a mounting plate (see page B11/13). Above this size it is always necessary to use the mounting plate.
Power terminals can be protected against direct finger contact by the addition of shrouds and/or insulated terminal blocks, to be ordered separately (see page B11/13).

Protection components

3-pole electronic thermal overload relays, TeSys LR9 F

Accessories (to be ordered separately)

Overload relays

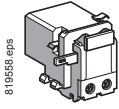

LA7 D03●

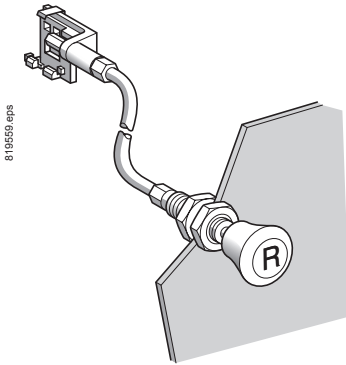

LA7 D305

Control accessories

Description	Sold in lots of	Unit reference	
Remote electrical reset device ⁽¹⁾	1	LA7D03● ⁽²⁾	
Remote Reset function control by flexible cable (length = 0.5 m)	1	LA7D305	
Remote Stop and/or Reset function control	Adapter for door mounted operator	1	LA7D1020
	Rod (snap-off end to obtain required length, between 17 and 120 mm)	10	ZA2BZ13
	Operating head for spring return pushbutton	1	ZA2B●●●● ⁽³⁾

Connection accessories

For mounting an LR9 F5●71 thermal overload relay together with an LC1 F185 contactor

Description	Reference
Set of 3 busbars	LA7F407

For mounting a thermal overload relay beneath a reversing contactor or star-delta contactors

Application	Width of terminal lug	Set of 3 busbars Reference	
For relay	For contactor		
		mm	
LR9 F5●57, F5●63, F5●67, LC1 F115 F5●69, F69, F71		15	LA7F401
LR9 F5●57, F5●63	LC1 F150, F185	20	LA7F402
LR9 F5●71, LR9 F71	LC1 F185	25	LA7F407
LR9 F5●71, LR9 F71	LC1 F225, F265	25	LA7F403
LR9 F7●75, F7●79, LR9 F75, F79	LC1 F225...F400	25	LA7F404
LR9 F7●81, LR9 F81	LC1 F400	25	LA7F404
LR9 F7●75, F7●79, F7●81, LR9 F75, F79, F81	LC1 F500	30	LA7F405
LR9 F7●81, LR9 F81	LC1 F630, F800	40	LA7F406

⁽¹⁾ The time for which the coil of remote electrical reset device **LA7 D03** can remain energised depends on its rest time: 1 s pulse duration with 9 s rest time; 5 s pulse duration with 30 s rest time; 10 s pulse duration with 90 s rest time. Maximum pulse duration of 20 s with rest time of 300 s. Minimum pulse time: 200 ms.

⁽²⁾ Reference to be completed by adding the coil voltage code.
Standard control circuit voltages,
(for other voltages, please consult your Regional Sales Office):

Volts	12	24	48	96	110	220/ 230	380/ 400	415/ 440
~ 50/60 Hz	–	B	E	–	F	M	Q	N
Consumption, inrush and sealed: < 100 VA								
---	J	B	E	DD	F	M	–	–

Consumption, inrush and sealed: < 100 W.

⁽³⁾ Stop: **ZA2 BL432** and Reset: **ZA2 BL639**.

Protection components

3-pole electronic thermal overload relays, TeSys LR9 F

Accessories (to be ordered separately)

Overload relays

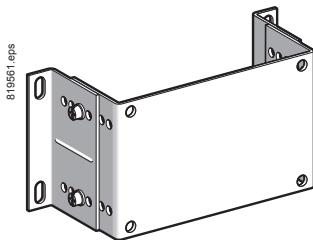

LA7 F90●

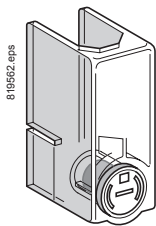

LA9 F70●

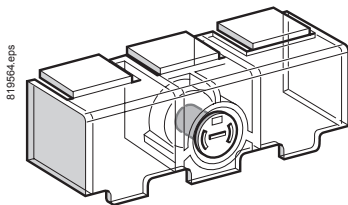

LA7 F70●

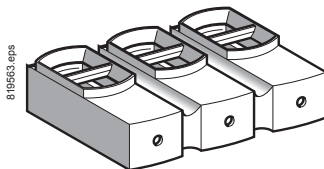

LA9 F103

Mounting plates for overload relay

For use with relays	Reference
---------------------	-----------

LR9 F5●57, F5●63, F5●67, F5●69, F5●71, LR9 F57, F63, F67, F69, F71	LA7F901
---	---------

LR9 F7●75, F7●79, F7●81, LR9 F75, F79, F81	LA7F902
---	---------

Sets of power terminal protection shrouds, single-pole

For use with relays	Number of shrouds per set	Set reference
---------------------	---------------------------	---------------

LR9 F5●57, LR9 F57	6	LA9F701
-----------------------	---	---------

LR9 F5●63, F5●67, F5●69, LR9 F63, F67, F69	6	LA9F702
---	---	---------

LR9 F5●71, LR9 F71	6	LA9F705
-----------------------	---	---------

LR9 F7●75, F7●79, F7●81, LR9 F75, F79, F81	6	LA9F703
---	---	---------

Power terminal protection shrouds, 3-pole

For use with relays	Reference
---------------------	-----------

LR9 F5●57, F5●63, F5●67, F5●69, LR9 F57, F63, F67, F69	LA7F701
---	---------

LR9 F5●71, LR9 F71	LA7F702
-----------------------	---------

LR9 F7●75, F7●79, F7●81, LR9 F75, F79, F81	LA7F703
---	---------

Insulated terminal blocks

For use with relays	Set of 2 blocks Reference
---------------------	---------------------------

LR9 F5●57, F5●63, F5●67, F5●69, LR9 F57, F63, F67, F69	LA9F103
---	---------

Marking accessories

Description	Sold in lots of	Unit reference
-------------	-----------------	----------------

Clip-in marker holder	100	LA7D903
-----------------------	-----	---------

Bag of 400 blank self-adhesive legends 7 x 16 mm	1	LA9D91
---	---	--------

Protection components

3-pole electronic thermal overload relays, TeSys LR9 F

Presentation

TeSys LR9 F electronic protection relays are especially suited to the operating conditions of motors.

They provide protection against:

- thermal overload of 3-phase or single-phase balanced or unbalanced circuits;
- phase failure and large phase unbalance,
- protracted starting times,
- prolonged stalled rotor condition.

LR9 F electronic protection relays are mounted directly below an LC1 F type contactor. They cover a range from 30 to 630 A, in eight ratings.

The settings can be locked by sealing the transparent protective cover.

A reset button is mounted on the front of the relay.

Two versions are available:

- simplified version: class 10: LR9 F●3●●, class 20: LR9 F●5●●,
- complete version: class 10, 10 A or class 20, selectable, conforming to EN 60947-4-1: LR9 F●●.

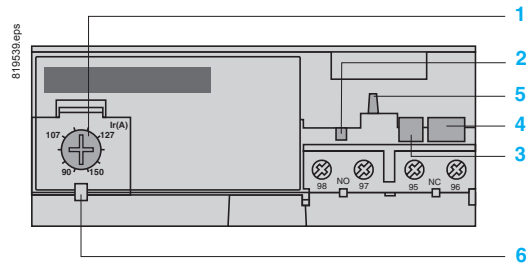

This latter version includes an alarm function which makes it possible to forestall tripping by load shedding.

Simplified version: class 10 or 20

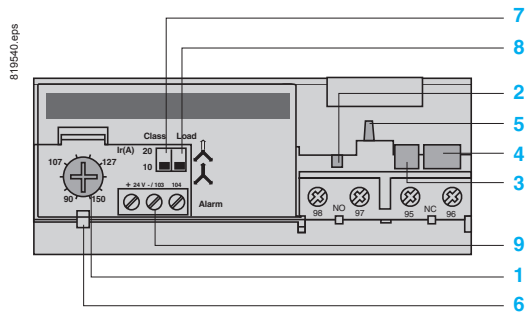

Complete version: class 10, 10 A or class 20, selectable, and alarm circuit



- 1 Ir adjustment dial
- 2 Test button
- 3 Stop button
- 4 Reset button
- 5 Trip indicator
- 6 Setting locked by sealing the cover
- 7 Class 10/class 20 selector switch
- 8 Selector switch for balanced load  /unbalanced load 
- 9 Alarm circuit

Protection components

3-pole electronic thermal overload relays, TeSys LR9 F

Overload relays

Environment			
Conforming to standards			IEC 60947-4-1, IEC 60255-8, IEC 60255-17, EN 60947-4-1 and VDE 0660
Product certifications			UL 508, CSA 22-2
Degree of protection	Conforming to VDE 0106		IP 20
	Conforming to IEC 60529		IP 20 on front of relay with accessories LA9 F103 or LA7 F70 , see page B11/13
Protective treatment	Standard version		"TH"
Ambient air temperature around the device (conforming to IEC 60255-8)	Storage	°C	-40...+85
	Normal operation	°C	-20...+55 ⁽¹⁾
Maximum operating altitude	Without derating	m	2000
Operating positions without derating	In relation to normal vertical mounting plane		Any position
Shock resistance	Permissible acceleration conforming to IEC 60068-2-7		13 gn - 11 ms
Vibration resistance	Permissible acceleration conforming to IEC 60068-2-6		2 gn - 5 to 300 Hz
Dielectric strength at 50 Hz	Conforming to IEC 255-5	kV	6
Surge withstand	Conforming to IEC 61000-4-5	kV	4
Resistance to electrostatic discharge	Conforming to IEC 61000-4-2	kV	8 (in air) 6 (in indirect mode)
Resistance to radiated radio-frequency disturbance	Conforming to IEC 61000-4-3	V/m	10
Resistance to fast transient currents	Conforming to IEC 61000-4-4	kV	2
Electromagnetic compatibility	EN 50081-1 and 2, EN 50082-2		Conforming

⁽¹⁾ For operating temperatures up to 70 °C, please consult your Regional Sales Office.

Protection components

3-pole electronic thermal overload relays, TeSys LR9 F

Overload relays

Electrical characteristics of power circuit								
Relay type		LR9	F5●57, F57	F5●63, F63 F5●67, F67 F5●69, F69	F5●71, F71	F7●75, F75 F7●79, F79	F7●81, F81	
Rated insulation voltage (Ui)	Conforming to IEC 60947-4	V	1000					
Rated operational voltage (Ue)	Conforming to VDE 0110 gr C	V	1000					
Rated impulse withstand voltage (Uimp)	Conforming to IEC 60947-1	kV	8					
Rated operational current (Ie)		A	30 to 630					
Short-circuit protection and coordination			See pages: A5/11, A5/12, A5/15 and A5/16					
Frequency limits	Of the operating current	Hz	50...60. For other frequencies, please consult your Regional Sales Office ⁽¹⁾					
Power circuit connections	Width of terminal lug	mm	20	25	25	30 LR9 F7●75 and LR9 F75 40 LR9 F7●79 and LR9 F79	40	
	Clamping screw		M6	M8	M10	M10	M12	
	Tightening torque	N.m	10	18	35	35	58	
Auxiliary contact electrical characteristics								
Conventional thermal current		A	5					
Short-circuit protection	By gG or BS fuses or by circuit-breaker GB2 CD10	A	5					
Control circuit connections	Flexible cable with cable end	1 conductor	mm ²	Min. 1 x 0.75			Max. 1 x 2.5	
		2 conductors	mm ²	2 x 1			2 x 1.5	
	Flexible cable without cable end	1 conductor	mm ²	1 x 0.75			1 x 4	
		2 conductors	mm ²	2 x 1			2 x 2.5	
	Solid cable	1 conductor	mm ²	1 x 0.75			1 x 2.5	
		2 conductors	mm ²	2 x 1			–	
	Tightening torque		N.m	1.2				
Maximum sealed current consumption of the coils of associated contactors (occasional operating cycles of contact 95-96)	a.c. supply	V	24	48	110	220	380	600
		VA	100	200	400	600	600	600
	d.c. supply	V	24	48	110	220	440	–
		W	100	100	50	45	25	–

⁽¹⁾ For applications involving the use of these overload relays with soft starters or variable speed drives, please consult your Regional Sales Office.

Protection components

3-pole electronic thermal overload relays, TeSys LR9 F

Overload relays

Operating characteristics				
Tripping class	Conforming to IEC 60947-4-1		10, 10 A and 20	
Temperature compensation		°C	-20...+70	
Reset	Manual on front of relay			
Fault indication	On front of relay			
Test function	On front of relay			
Stop function	Actuation of N/C contact, without affecting N/O contact			
Tripping thresholds	Conforming to IEC 60947-4-1	Alarm	A	1.05 ± 0.06 I _n
		Tripping	A	1.12 ± 0.06 I _n
Sensitivity to phase failure	Conforming to IEC 60947-4-1		Tripping in 4 s ± 20 % in the event of phase failure	
Adjustment (nominal motor current)	Setting dial on front of relay			
Security sealing	Yes			

Alarm circuit characteristics			
Rated supply voltage	d.c. supply	V	24
Supply voltage limits		V	17...32
Current consumption	No-load	mA	≤ 5
Switching current		mA	0...150
Protection	Short-circuit and overload		Auto-protected
Voltage drop	Closed state	V	≤ 2.5
Connection	Flexible cable without cable end	mm ²	0.5...1.5
Tightening torque		N.m	0.45

LR9 F tripping curve

Average operating times depending on multiples of the setting current

Class 10

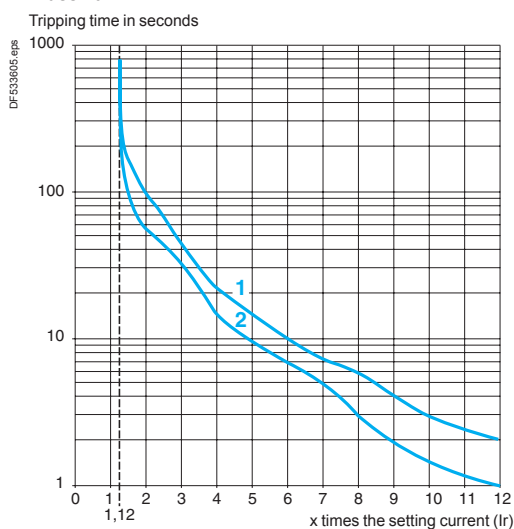

Class 20

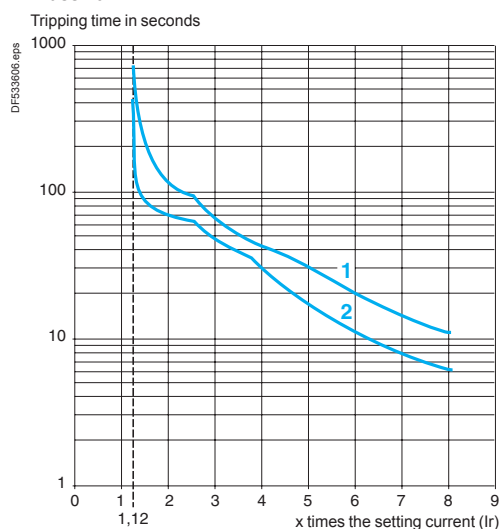

- 1 Cold state curve
- 2 Hot state curve

Protection components

3-pole electronic thermal overload relays, TeSys LR9 F

Overload relays

Common side view

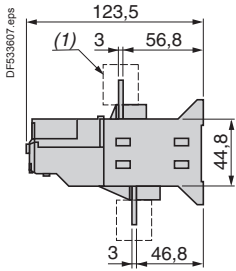

LR9 F57, F71

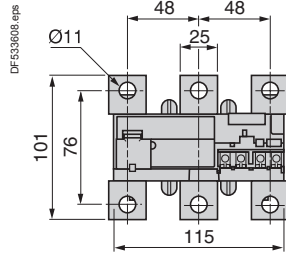

LR9 F57, F563, F567, LR9 F569, F57, F63, F67, F69

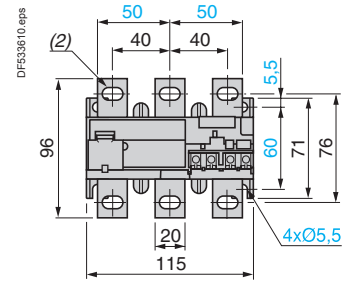
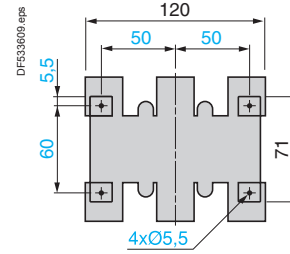

(1) Terminal shroud LA9 F70

Common side view

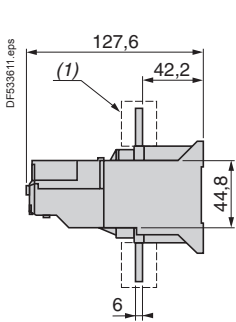

(2) 6.5 x 13.5 for LR9 F57 and F57. 8.5 x 13.5 for LR9 F563, F567, F569, F63, F67, F69

LR9 F75, F79, F81, LR9 F75, F79, F81

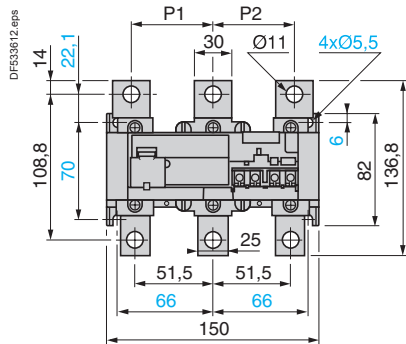

LR9 F781 (for mounting beneath LC1 F630 and F800), LR9 F81

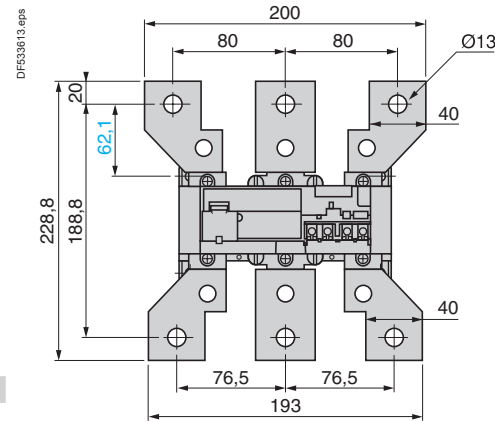

(1) Terminal shroud LA9 F70

	P1	P2
LR9 F75, F75	48	48
LR9 F79, F79, F81, F79, F81	55	55

Direct mounting beneath contactor LC1 F

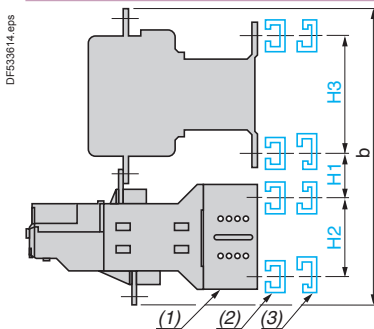

Mounting beneath contactors: reversing LC2 F or star-delta LC3 F

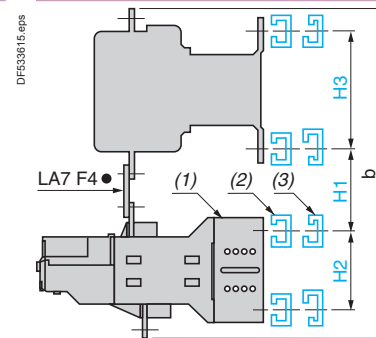

Mounting plate for LR9 F

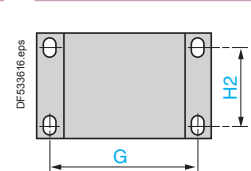

LA7	G
F901	145
F902	190

Contactors LC1	With LR9 relays	b	H1	H2	H3
F115	F57, F563, F567, F569, F57, F63, F67, F69	240	30	50	120
F150	F57, F563, F567, F569, F57, F63, F67, F69	246	30	50	120
F185	F57, F563, F567, F569, F57, F63, F67, F69	250	30	50	120
F225	F57, F71, F75, F79, F75, F79	273	40	50	120
F265	F57, F71	279	40	50	120
	F75, F79, F75, F79	314	60	58	120
F330	F75, F79, F75, F79	317	60	58	120
F400	F75, F79, F781, F75, F79, F81	317	60	58	180
F500	F75, F79, F781, F75, F79, F81	346	70	58	180
F630, F800	F781, F81	510	110	58	180

Contactors LC1	With LR9 relays	b	H1	H2	H3
F115	F57, F563, F567, F569, F57, F63, F67, F69	279	60	50	120
F150	F57, F563, F567, F569, F57, F63, F67, F69	283	60	50	120
F185	F57, F563, F567, F569, F57, F63, F67, F69	285	60	50	120
F225	F57, F71, F75, F79, F75, F79	360	100	58	120
F265	F57, F71	332	90	50	120
	F75, F79, F75, F79	363	100	58	120
F330	F75, F79, F75, F79	364	100	58	120
F400	F75, F79, F781, F75, F79, F81	364	100	58	180
F500	F75, F79, F781, F75, F79, F81	390	110	58	180
F630, F800	F781, F81	509	120	58	180

(1) Relay mounting plate LA7 F90, see page B11/13

(2) AM1 EC or AM1 DF for LC1 F115 to F630 and LC1 F800

(3) DZ5 MB for LC1 F115 to F400

Schemes

LR9 F57...F7...F81

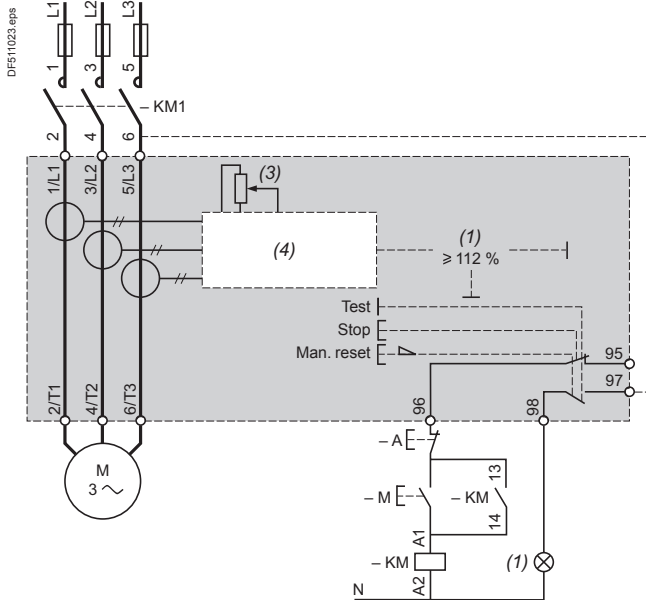

LR9 F57...F81 (with alarm)

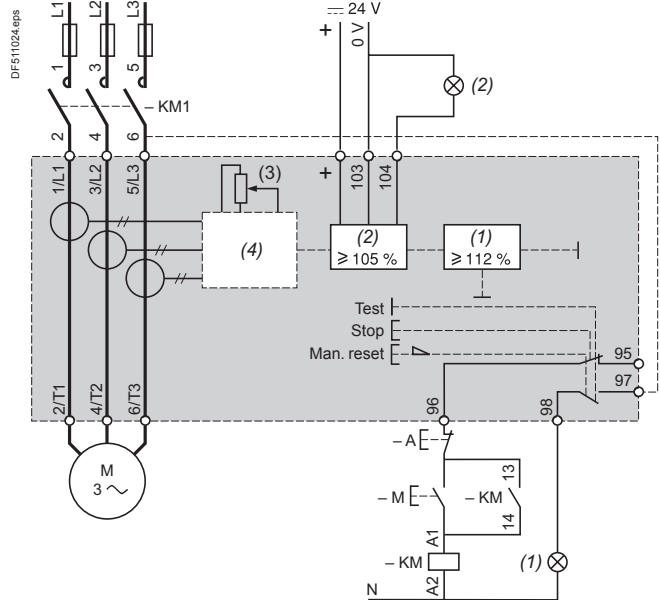

- (1) Tripped on thermal overload.
- (2) Overheating alarm.
- (3) Setting current.
- (4) Specialised circuit.

Setting-up the special functions of TeSys LR9 F thermal overload relays

Setting the relay

- Lift the transparent cover 7 to gain access to the various settings.
- Adjustment is achieved by turning dial 1 which is graduated directly in Amperes.
- The setting can be locked by sealing the cover 7.

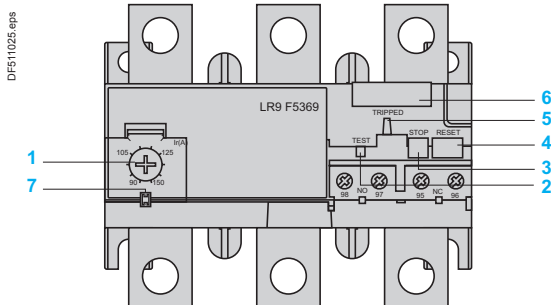

"Stop" function 3

Stop

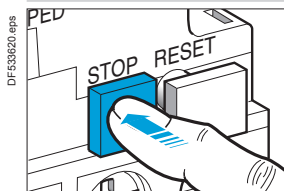

- The "Stop" function is obtained by pressing the red "STOP" button 3.
- Pressing the Test button:
 - actuates the N/C contact,
 - has no effect on the N/O contact.
- The "STOP" button can be locked by fitting a "U" clip (reference: LA7 D901).

"Test" function 2

Test

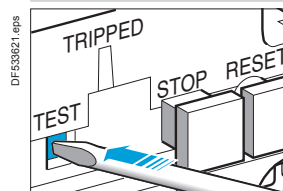

- The "Test" function is obtained by pressing the red "TEST" button 2 with a screwdriver.
- Operation of the "TEST" button simulates tripping of the relay and:
 - actuates both the N/O and N/C contacts,
 - actuates the trip indicator 5.

Trip indicator

