

Star-Delta Timer with Free power, compact size W38×H42mm

■ Features

- Wide power supply range
: 100-240VAC 50/60Hz /24-240VDC (universal)
- Wide time setting range and switching time
- T1(setting time): selectable 0.5 to 100 sec.
- T2(switching time): selectable 0.05, 0.1, 0.2, 0.3, 0.4, 0.5 sec.
- Close and DIN rail mounting
with a dedicated socket (PS-M8) width 41mm
- Easy mounting and installation/maintenance
with dedicated bracket for DIN 48×48mm
- Application: Starting large capacity motors



⚠ Please read "Caution for your safety" in operation manual before using.



■ Ordering information

ATS	8	SD	-	4		
				Power supply	4	100-240VAC / 24-240VDC universal
				Time operation	SD	Star-Delta type
				Number of plug pins	8	8-pin plug type
				Item	ATS	Small Analog Timer

※Sockets (PG-08, PS-08, PS-M8) are sold separately.

■ Specifications

Model		ATS8SD-4
Function		Star-Delta Timer
Control time setting range		0.5sec to 100sec (max. time)
Power supply		100-240VAC 50/60Hz /24-240VDC universal
Allowable voltage range		90 to 110% of rated voltage
Power consumption		100-240VAC : 3VA, 24-240VDC : 1.5W
Return time		Max. 100ms
Time operation		Power ON Start type
Control output	Contact type	λ contact: SPST(1a), Δ contact: SPST(1a)
	Contact capacity	250VAC 3A resistive load
Relay life cycle	Mechanical	Min. 10,000,000 operations
	Electrical	Min. 100,000 operations (250VAC 3A resistive load)
Repeat error		Max. ±0.2% ±10ms
λ setting error		Max. ±5% ±50ms
Voltage error		Max. ±0.5%
Temperature error		Max. ±2%
λ -Δ switching time error		Max. ±25%
Insulation resistance		100MΩ (at 500VDC megger)
Dielectric strength		2000VAC 50/60Hz for 1 min.
Noise resistance		±2kV the square wave noise (pulse width 1μs) by noise simulator
Vibration	Mechanical	0.75mm amplitude at frequency of 10 to 55Hz(for 1 min.) in each of X, Y, Z directions for 1 hour
	Malfunction	0.5mm mplitude at frequency of 10 to 55Hz(for 1 min.) in each of X, Y, Z directions for 10 min.
Shock	Mechanical	300m/s ² (approx. 30G) in each of X, Y, Z directions 3 times
	Malfunction	100m/s ² (approx. 10G) in each of X, Y, Z directions 3 times
Environment	Ambient temperature	-10 to 55°C, storage: -25 to 65°C
	Ambient humidity	35 to 85%RH, storage: 35 to 85%RH
Approval		CE c UL US
Accessory		Bracket
Unit weight		Approx. 72g

※Environment resistance is rated at no freezing or condensation.

(A) Photo electric sensor

(B) Fiber optic sensor

(C) Door/Area sensor

(D) Proximity sensor

(E) Pressure sensor

(F) Rotary encoder

(G) Connector/Socket

(H) Temp. controller

(I) SSR/Power controller

(J) Counter

(K) Timer

(L) Panel meter

(M) Tacho/Speed/ Pulse meter

(N) Display unit

(O) Sensor controller

(P) Switching mode power supply

(Q) Stepper motor& Driver&Controller

(R) Graphic/ Logic panel

(S) Field network device

(T) Software

(U) Other

ATS8SD-4

■ Connections

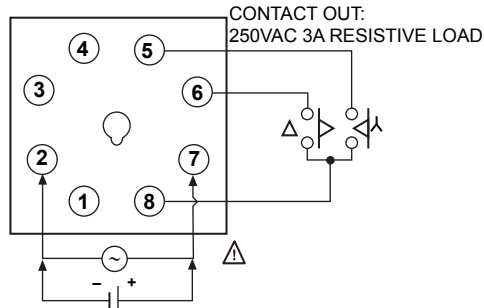

SOURCE : 100-240VAC 50/60Hz, 24-240VDC universal

■ Dimensions

(unit: mm)

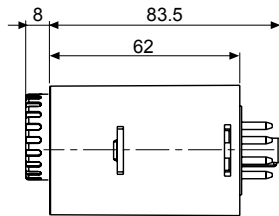
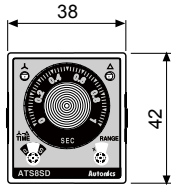

● Panel cut-out

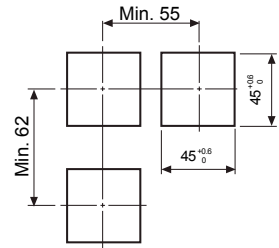

● Bracket

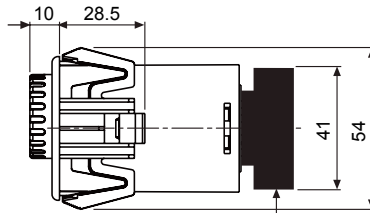
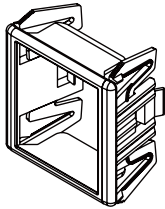

8-pin socket (sold separately)
※Refer to G-15 page.

■ Parts description

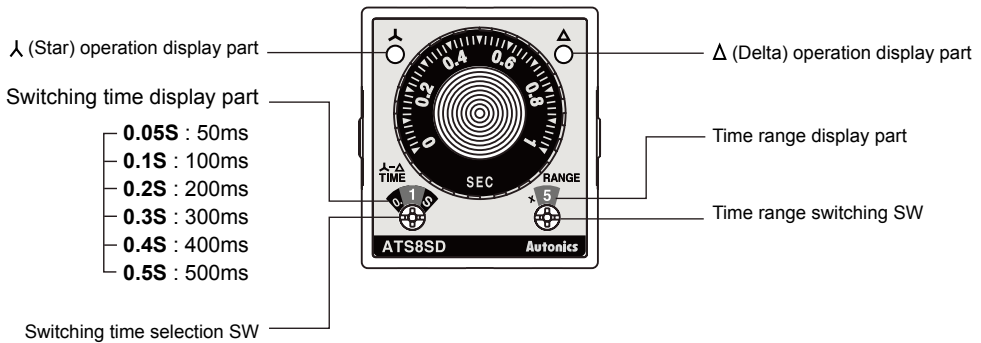

Small Star-Delta Timer

Time range

1. T1(setting time) time

Time range	Time unit	Setting time range
5	sec	0.5 to 5sec
10		1 to 10sec
50		5 to 50sec
100		10 to 100sec

2. T2(λ - Δ switching time) time (unit: sec)

Switching time display part	0.05S	0.1S	0.2S	0.3S	0.4S	0.5S
T2 (λ - Δ switching time)	0.05	0.1	0.2	0.3	0.4	0.5

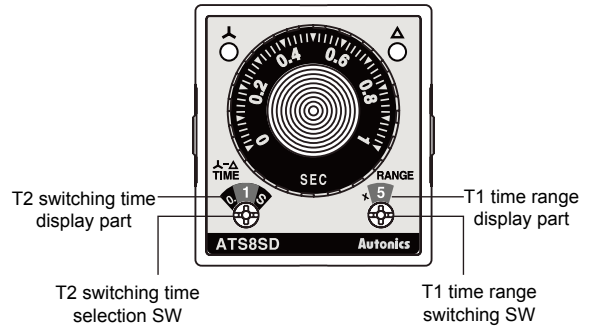

Operation

When power is applied, λ contact will be ON. When reaching to T1 setting time, λ contact will be OFF and Δ contact will be ON after switching time of T2 is passed. If the power is OFF, λ contact will be OFF.

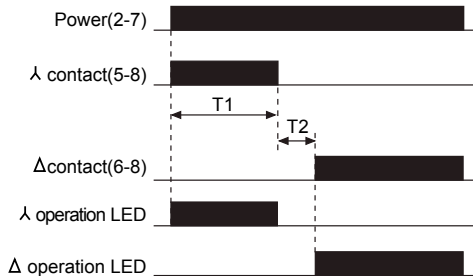

※T1: setting time (λ contact operation time)

※T2: λ - Δ switching time (λ contact and Δ contact are OFF simultaneously at power ON)

Proper usage

- Please supply power quickly at once with using switch or relay contact. Otherwise it may cause time error or power reset failure.
- When supplying power for a long time, timer life cycle may be shorten due to overheat of inner components of timer.
- When supplied power of timer is DC, be sure that the polarity.
- When supplying the power to the timer, connection shown in (Fig. 1) might cause malfunction due to leakage current through R and C. Please connect R and C as shown in (Fig. 2) to prevent malfunction.

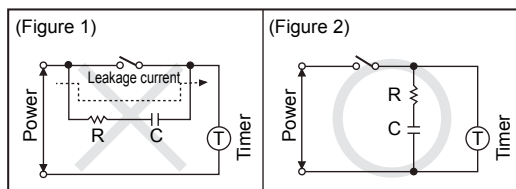

- Change the setting time (T1), time range or switching time(T2). Otherwise, it might cause malfunction if changing the setting time (T1), time range or switching time(T2) during operation.
- Do not use this unit at below places.
 - Place where temperature or humidity is out of the rated specifications.
 - Place where there is condensation by temperature changes.
 - Place where flammable gas or corrosive gas.
 - Place where there are dust, oil or severe vibration or impact.
 - Place where strong alkalis or acids are used.
 - Place where there are direct ray of the sun.
 - Place where strong magnetic field or electric noise are generated.

(A) Photo electric sensor

(B) Fiber optic sensor

(C) Door/Area sensor

(D) Proximity sensor

(E) Pressure sensor

(F) Rotary encoder

(G) Connector/Socket

(H) Temp. controller

(I) SSR/ Power controller

(J) Counter

(K) Timer

(L) Panel meter

(M) Tacho/ Speed/ Pulse meter

(N) Display unit

(O) Sensor controller

(P) Switching mode power supply

(Q) Stepper motor& Driver&Controller

(R) Graphic/ Logic panel

(S) Field network device

(T) Software

(U) Other