



CONOTEC CO., LTD. www.conotec.co.kr
FOX-300SERIES

Operating Manual



Thank you very much for selecting our products.

1 Caution for your safety

Please read this instruction carefully before using this controller

※ The manual's information & specification can changeable to improve its quality without any notification.

⚠ Safety

1. Pls use this item after installing the duplex safety device in which is applied at dangerous factors such as serious human injury or serious damages of property & important machine because this item is not designed as a safety device.
2. Do not checking or repairing when it is power on.
3. Please check the terminal number before connecting power supply.
4. Do not disassemble or open, remodel, repair without any permission.

⚠ Safety Instruction and Hazard Warnings

- Please read the operating manual through completely before putting the device into operation.
- We will not assume any responsibility for damage to assets or persons caused by improper handling or failure to observe the safety instructions or hazard warnings.
- For safety and licensing reasons, unauthorized conversion and/or modification of the device is not permitted.
- Do not exceed the maximum permissible current - in case of higher loads, use a contactor of adequate power. Make sure that the supplied voltage matches the values specified for the instrument.
- The device must be adequately protected from water and dust as per the application and must be accessible via the use of appropriate tools
- The device must not be exposed to extreme temperature, sunlight, strong vibrations or high levels of humidity.
- Operation or installation is not permitted under unfavorable ambient conditions such as wetness or excessive induction loads or solenoid and dust, combustible gases, vapors or solvents, especially high-frequency noise
- Avoid operation or installation close to high-frequency fields such as welding devices, sewing machines, wireless transmitter, radio systems, SCR controller, etc
- Do not install the sensor cable nearby signal cable, power cable, load cable
- Please use the shield cable when the sensor cable's lengthen, however do not make it too much longer.
- Please use the sensor cable without any cutting or flaw, blemish.
- The device is not a toy and should be kept away from children.
- Installation work must only be carried out by suitably qualified personnel who are familiar with the hazards involved and with the relevant regulations.
- You shouldn't tinker with anything or the product may not be opened or disassembled unless you know what you're doing. Please ask us about this questioning.

⚠ Danger

- Caution, Danger of Electric Shock
- 1. Electric shock - Do not contact AC terminal during the current carrying. Electric shock can occur.
- 2. In case of checking the input power, it should be disconnected without fail.

2 Composition

Model	Sensor	Range	Size	Function
FOX-300-2S	SH-104	-29.0 ~ 99.9°C 0.0 ~ 99.9%	W72 X H72mm	temp.,humi.control
FOX-300A-1	HCPV-220NH	-40.0 ~ 65.0°C 10 ~ 95%	W72 X H72mm	temp.control
FOX-300AR1				temp.,humi.control RS485communication
FOX-300JB-1			temp.control humi.control	
FOX-300JR1	temp.,humi.control RS485communication	W194X H241mm		
FOX-8300R1	temp.,humi.control RS485 communication	W94 X H150mm		

※ 300 series

Temp./humi. range can be changed to -55.0°C ~ 99.9°C / 10~95% if using

Temp. sensor : FS-200N(NTC 10K)
Humi. sensor : HCPV-220

instead of HCPV-220NH(Temp.&humi.)

▶ FOX-300JB-1/JR1

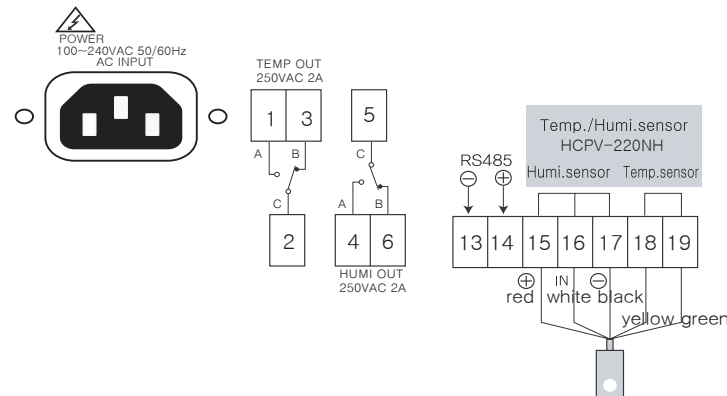

▶ FOX-8300-1/R1

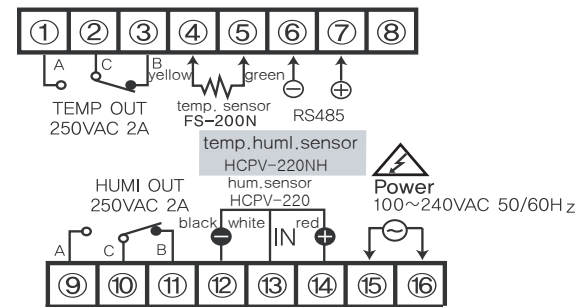

5 Size & Dimension

▶ FOX-300A-1/AR1,300-2S (72x72x110mm)

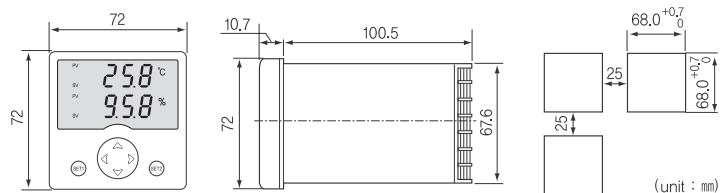

▶ FOX-300JB-1/JR1 (194x241x60mm)

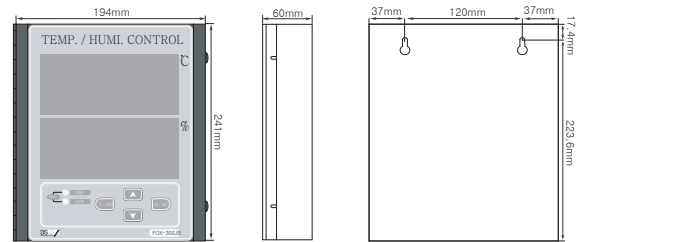

▶ FOX-8300-1/R1 (94x150x39mm)

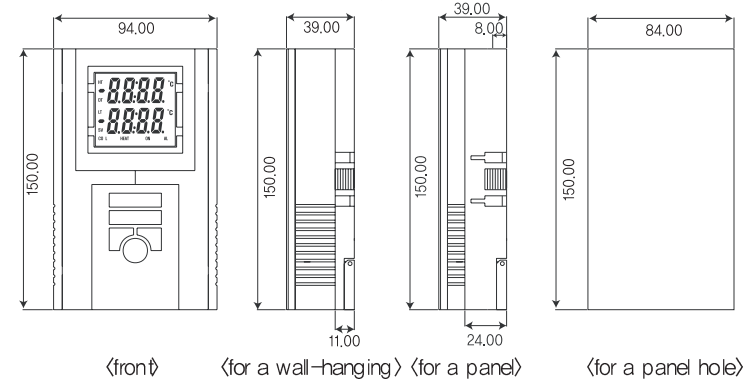

3 Part name

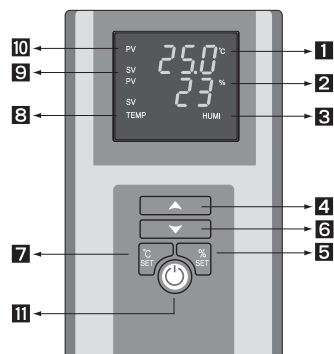

- 1: Display of the present temperature (red color)
- 2: Display of the present humidity (green color)
- 3: output display of the humidity's working
- 4: Up
- 5: Humidity mode
- 6: Down
- 7: Temperature mode
- 8: output display of the temperature' working
- 9: Display of the set value
- 10: Display of the measuring value
- 11: Power supply

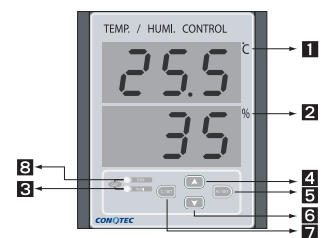

- 1: Display of the present temperature (red color)
- 2: Display of the present humidity (green color)
- 3: output display of the humidity's working
- 4: Up
- 5: Humidity mode
- 6: Down
- 7: Temperature mode
- 8: output display of the temperature' working
- 9: Display of the set value
- 10: Display of the measuring value
- 11: Power supply

4 Connection

output : 250VAC 2A
Please make use of the power relay or a suitable magnet surely.

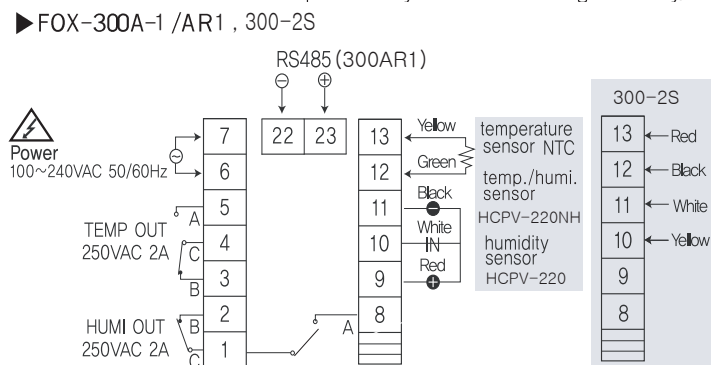

6 Temperature

Setting for temperature

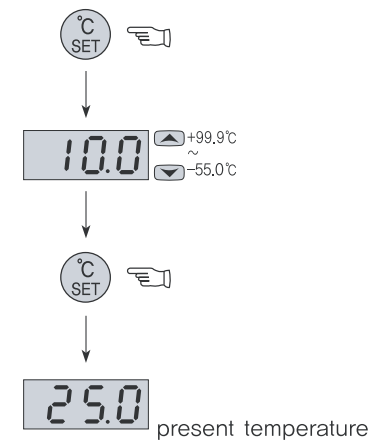

Setting for temperature programs

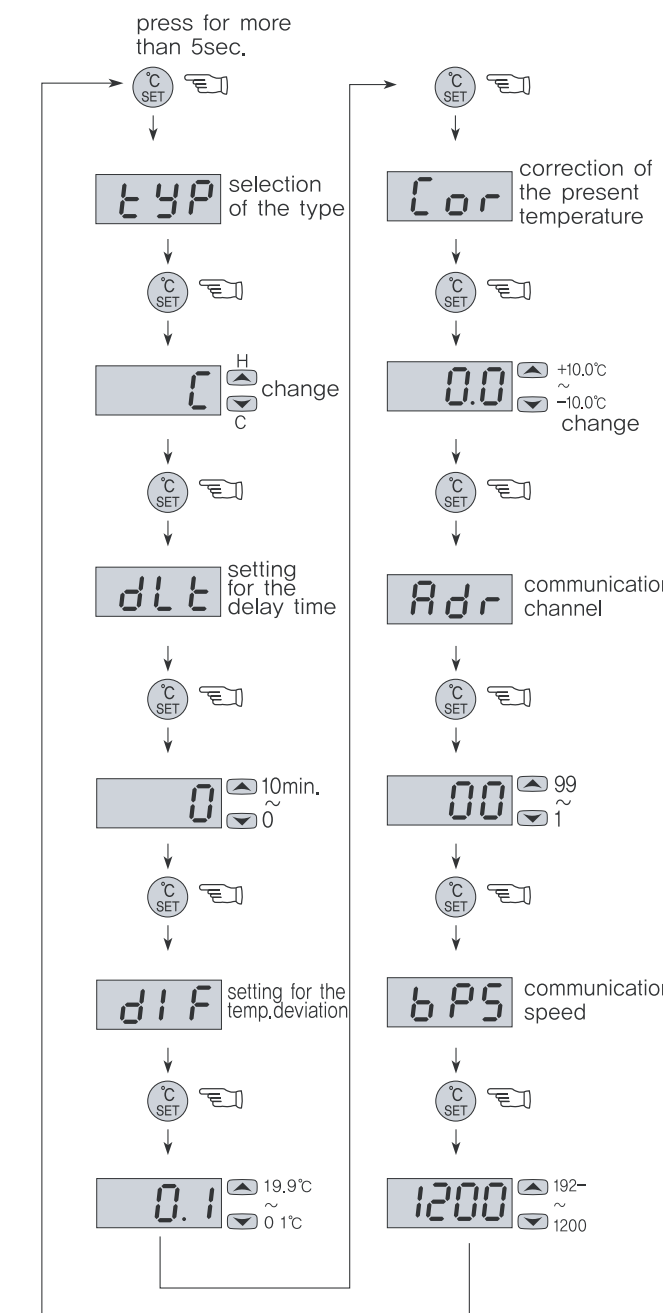

7 Humidity

Setting for the humidity

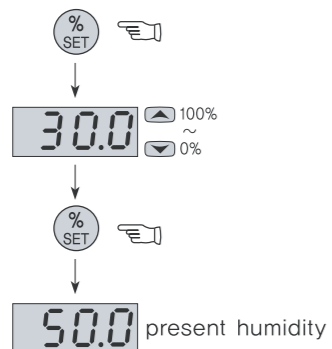

Setting for humidity programs

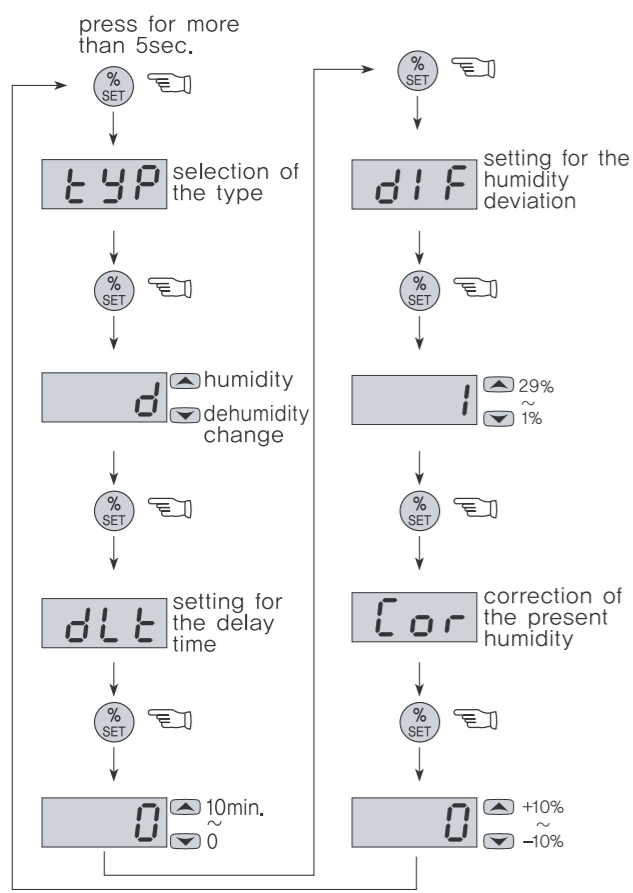

※To change it with program mode, press the --key for more than 5 second in the present temperature display mode.

※The set or programming mode is terminated, if you press the **o-k** key, parameters(set values) are saved after the display shows OK letter or return to present temperature automatically after 30 second.

8 Detailed manual

- typ** : temperature : possible to select the coding or heating, humidity : possible to select the humidity or dehumidity.
- dif** : Setting for temperature deviation
 - In the ON/OFF control, it needs at regular interval between ON and OFF.
 - By operating the ON/OFF control frequently, the relay or its output contact can be damaged quickly and it also occurs the hunting(oscillating, chattering) by virtue of external noise. You can make use of the temperature deviation in order to protect its relay or contact and so on.

ex=> The method of the temp. deviation when ON/OFF control

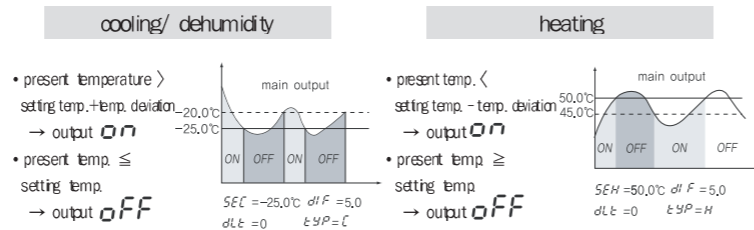

- dlt** : Delay time of the output
It is widely used as followings :
 - in case of operating the ON/OFF control very often,
 - to protect the operation machinery when re-input of the power supply or momentary stoppage of power supply

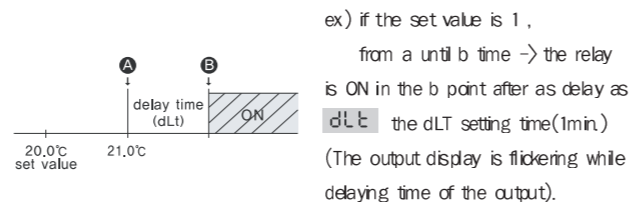

- cor** : Correction of the present temperature.
- It is used for the correction of a discrepancy between the display temperature and an actual temperature
ex) real temp. : 10.0°C
display : 12.0°C → **cor** : 0.0 ⇒ -2.0 correction
→ 10.0°C display

- Adr** : Communication channel
- To designate the channel while RS485 communication working
- bps** : Communication speed(velocity)
 - 120, 1200 : 1200bps
 - 240, 2400 : 2400bps
 - 480, 4800 : 4800bps
 - 960, 9600 : 9600bps
 - 192, 1920 : 19200bps
 (Start bit 1, Stop bit 1, Non parity)

9 Temp.range & set value when deliver

	function	display	range	set values when deliver	remarks
setting temp.	setting temp. (HCPV-220NH)		-40.0~65.0	10.0	FOX-300-2S
	setting temp. (SH-104)		-29~99.9		Other 300 series
setting programs	selection of the type	typ	C/H	C	H : heating C : cooling
	temp.deviation	dif	0.1~19.9	1.0	
	delay time	dlt	0~10	0	minute
	correction of the temp. (HCPV-220NH)	cor	-10.0~10.0	0.0	correct for a discrepancy between the display temp. and an actual temperature.
	correction of the temp. (SH-104)	cor	-9.9~9.9		
	communication channel	Adr	1~99	0	RS485 communication
	communication speed	bps	1200/2400/4800/9600/19200	9600	RS485 communication

10 Humi. range & set value when deliver

	function	display	range	set values when deliver	remarks
setting humi.	setting humidity (HCPV-220NH)		0~100%	30	HCPV-220NH
	setting humidity (SH-104)		0.0~99.9%	30.0	SH-104
setting programs	selection of the type	typ	d/H	d	H : humidity d : dehumidity
	humidity deviation (HCPV-220NH)	dif	1~29	1	
	humidity deviation (SH-104)	dif	0.1~29.9	0.1	
	delay time (HCPV-220NH)	dlt	0~10	0	minute
	correction of the humidity. (HCPV-220NH)	cor	-10~10	0	correct for a discrepancy between the display humi. and an actual humidity.
	correction of the humidity. (SH-104)	cor	-9.9~9.9		

11 Communication output

Interface

specification	in conformity EIA RS485
maximum connection	32(However, available to set the Address from 01 until 99)
the method of communication	two-wire half-duplex operation
synchronous system	asynchronous system
communication distance	within 1.2km
communication speed	1200/2400/4800/9600/19200bps(possible to select)
Start bit	fixed 1bit
Stop bit	fixed 1bit
Parity bit	none
Data bit	fixed 8bit
Protocol	BCC

System

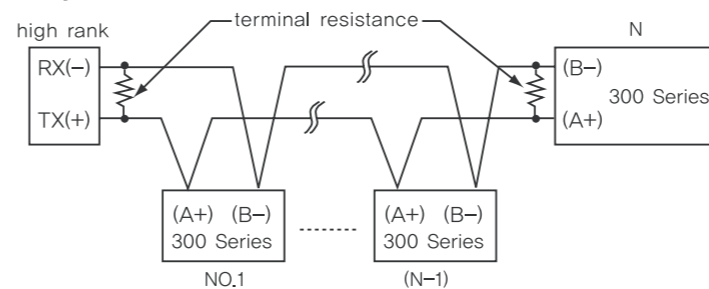

Definition between communication command and Block

Show the Format of the Command

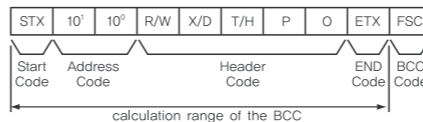

Show the Format of the Response

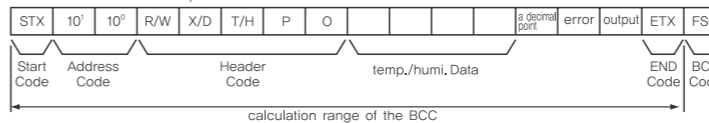

- Start Code**
show the lead(head) of the Block
ACK will be added in case of STX->[02H], Response
- Address Code**
A high rank system can discriminate the channel code number among FOX-300series
It is available to set between 01 and 99(BCD ASC II)
- Header Code**
show the command name as a alphabetic letter
RX(reading demand) → R[52H], X[58H]

- RD(reading response) → R[52H], D[44H]
WX(writing demand) → W[57H], X[58H]
WD(writing response) → W[57H], D[44H]
TPO(temperature measuring value) → W[54H], P[50], O[30H]
HPO(temperature measuring value) → H[48H], P[50], O[30H]
- Composition of Data
Data is displayed as "Hexadecimal"
 - Decimal point → O[30H] there is no "decimal point"
1[31H] there is "decimal point"
 - Error → O[30H] there is no "error"
1[31] interrupted of the sensor's cable
2[32] short-circuited error of the sensor
 - Output → O[30H] T/H OUT ON
3[33H] T/H OUT OFF
 - END Code
show the end(close) of the Block ETX → [03H]
 - BCC(Block Check Character)
show the XOR arithmetic and logic values from the start(STX) to the ETX
 - the others : As of no response of the ACK
 - in case of not equivalent to the channel after receiving STX
 - in case of generating the Receive Buffer Overflow
 - in case of not equivalent to the communication's set values or baud rate
 - treatment- in case of no response of the ACK
 - check the cable
 - check the communication's condition (set values)
 - if the main cause of the status is the noise, try to do communication practicing 3times until recovering normally.
 - change the communication speed in case of bring about the communication's error frequently.

12 Error message

- Indicating ERROR on using items
 - This **Err!** is the damage of memory data for various of inner-DATA due to be got nosied strongly from outside while using this items. Please request us A/S by return.
- Although our controller is designed as the complementary measures regarding the noise from outside, it is not enduring against the noise with endlessly.
- If noise(2KV) disordering become an inflow, the inner-part will be damaged.
- When shows these letters **o-E** (open error), **s-E** (short error) it is the case of the error of the sensor.

■ H.Office : CONOTEC B/D 2nd floor, 26, Yunsan-ro, Geumjeong-gu, Busan, 46269 Rep. of KOREA
 ■ Lab : CONOTEC B/D 3rd floor, 26, Yunsan-ro, Geumjeong-gu, Busan, 46269 Rep. of KOREA
 ■ Factory : CONOTEC B/D B1, 26, Yunsan-ro, Geumjeong-gu, Busan, 46269 Rep. of KOREA
 ■ A/S TEL : +82-51-819-0426
 ■ FAX : +82-51-819-4562
 ■ Homepage : <http://www.conotec.co.kr> ■ E-mail : conotec@conotec.co.kr

※This device works proper operation with:
 Surrounding Temp. : 0°C~60°C
 Surrounding Humi. : below 80%RH
 Regular power : 100~240VAC 50/60Hz 9VA

■ Main products & Development
 - Digital temperature controller
 - Digital humidity controller
 - Digital timer