

Electronic Softstarter

Getting Started Manual

Edition: April 2010

SS7IM01EI Rev. E

SAFETY SYMBOLS

Always follow safety instructions to prevent accidents and potential hazards from occurring.

**WARNING**

This symbol means improper operation may result in serious personal injury or death.

**CAUTION**

Identifies shock hazards under certain conditions. Particular attention should be given because dangerous voltage may be present. Maintenance operation should be done by qualified personnel



Identifies potential hazards under certain conditions. Read the message and follow the instructions carefully.



Identifies shock hazards under certain conditions. Particular attention should be given because dangerous voltage may be present.

Edition of September 2009

This publication could present technical imprecision or misprints. The information here included will be periodically modified and updated, and all those modifications will be incorporated in later editions. To consult the most updated information of this product you might access through our website www.lsis.biz where the latest version of this manual can be downloaded.

Revisions

Date	Revision	Description
April 2010	E	Original version.

INDEX

SAFETY INSTRUCTIONS	7
1. INTRODUCTION	9
1.1. Code Description.....	9
1.2. Description of the Equipment	10
2. INSTALLATION AND CONNECTION	11
2.1. Environmental Conditions	11
2.2. Degree of Protection	11
2.3. Installation of the Softstarter	11
2.4. Power Loss Dissipation.....	12
2.5. Power Connections and Control Wiring	12
2.6. Considerations before Commissioning the SS7 Softstarter	17
3. POWER RANGE	19
3.1. SS7 Standard Softstarter	19
3.2. SS7 Softstarter with Internal Bypass.....	20
4. TECHNICAL CHARACTERISTICS	22
5. DIMENSIONS	23
5.1. Dimensions for Frames 1 and 2	23
5.2. Dimensions for Frames 3 and 4	24
5.3. Dimensions for Frame 5.....	25
6. CE CONFORMITY DECLARATION	26
7. CONNECTION TERMINALS	27
7.1. Control Connection Drawing	27
7.2. Terminal Description	28
8. DISPLAY UNIT AND KEYPAD OPERATION	29
8.1. LCD Display	29
8.2. Control Keys	29
8.3. Start and Stop-Reset / Slow Speed Buttons	30
9. STATUS MESSAGES	31
10. GENERAL INFORMATION SCREENS	33
11. PARAMETERS DESCRIPTION	34
11.1. Group 1 – G1: MENU OPTIONS.....	34
11.2. Group 2 – G2: NAMEPLATE.....	35
11.3. Group 3 – G3: PROTECTIONS	35
11.4. Group 4 – G4: ACCELERATION	37
11.5. Group 5 – G5: DECELERATION	39
11.6. Group 6 – G6: INPUTS	40
11.7. Group 7 – G7: OUTPUTS	42
11.8. Group 8 – G8: DUAL SETTING	44
11.9. Group 9 – G9: COMPARATORS	47
11.10. Group 10 – G10: FAULT HISTORY	48
11.11. Group 11 – G11: STATISTICS.....	49
11.12. Group 12 – G12: SLOW SPEED.....	50
11.13. Group 13 – G13: DC BRAKE	51
11.14. Group 14 – G14: SERIAL COMMUNICATION.....	51
11.15. Group 15 – G15: AUTO RESET	52
11.16. Group 16 – G16: PUMP CONTROL 1.....	52

12. FAULT MESSAGES. DESCRIPTION AND ACTIONS	54
13. COMMONLY USED CONFIGURATIONS	58
13.1. Settings	58
13.2. Recommended Power Installation.....	58
13.3. Operation Mode	58
14. CONFIGURATION REGISTER	61

SAFETY INSTRUCTIONS

IMPORTANT!

- Read this manual carefully to maximise the performance of this product and to ensure its safe use.
- In this manual, safety messages are classified as follows:



WARNING

Do not remove the cover while the power is applied or the softstarter is in operation. Otherwise electric shock could occur.

Do not run the softstarter with the front cover removed. Otherwise you may get an electric shock due to the high voltage terminals or exposure of charged capacitors.

Do not remove the cover except for periodic inspections or wiring, even if the input power is not applied. Otherwise you may access the charged circuits and get an electric shock.

Operate the switches with dry hands. Otherwise you may get an electric shock.

Do not use cables with damaged insulation. Otherwise you may get an electric shock.

Do not subject the cables to abrasions, excessive stress, heavy loads or pinching. Otherwise, you may get an electric shock.



CAUTION

Install the softstarter on a non-flammable surface. Do not place flammable material nearby. Otherwise fire could occur.

Disconnect the input power if the softstarter gets damaged. Otherwise it could result in a secondary accident or fire.

After the input power is applied or removed, the softstarter will remain hot for a couple of minutes. Touching hot parts may result in skin burns.

Do not apply power to a damaged softstarter or to a softstarter with parts missing even if the installation is complete. Otherwise you may get an electric shock.

Do not allow lint, paper, wood chips, dust, metallic chips or other foreign matter into the softstarter. Otherwise fire or accident could occur.



WARNINGS

RECEPTION

- The SS7 Softstarters are carefully tested and perfectly packed before leaving the factory.
 - In the even of transport damage, please ensure that you notify the transport agency and LS Industrial Systems: +82 2 2034 4870 or your nearest agent, within 24hrs from receipt of the goods.
-

UNPACKING

- Make sure model and serial number of the softstarter are the same on the box, delivery note and unit.
 - Each softstarter is supplied with a SS7 technical manual.
-

RECYCLING

- Packing of the equipments should be recycled. For this, it is necessary to separate different materials included (plastic, paper, cardboard, wood, ...) and deposit them on proper banks.
 - Waste products of electric and electronic devices should be selectively collected for their correct environmental management.
-

SAFETY

- Before operating the softstarter, read this manual thoroughly to gain an understanding of the unit. If any doubt exists then please contact LS Industrial Systems: +82 2 2034 4870 or your nearest agent.
 - Wear safety glasses when operating the softstarter with power applied and the front cover is removed.
 - Handle the softstarter with care according to its weight.
 - Install the softstarter according to the instructions within this manual.
 - Do not place heavy objects on the softstarter.
 - Ensure that the mounting orientation is correct.
 - Do not drop the softstarter or subject it to impact.
 - The SS7 softstarters contain static sensitive printed circuits boards. Use static safety procedures when handling these boards.
 - Avoid installing the softstarter in conditions that differ from those described in the *Technical Characteristics* section.
-

CONNECTION PRECAUTIONS

- To ensure correct operation of the softstarter it is recommended to use a SCREENED CABLE for the control wiring.
 - Do not disconnect motor cables if input power supply remains connected. The internal circuits of the SS7 Series will be damaged if the incoming power is connected and applied to output terminals (U, V, W).
 - During acceleration and deceleration mode, it is recommended to unplug a capacitor battery.
 - The SCR's used at the power circuit are electronic switches therefore it is recommended to use the configurations as shown on Fig. 2.2 or Fig. 2.3 of this manual.
-

TRIAL RUN

- Verify all parameters before operating the softstarter. Alteration of parameters may be required depending on application and load.
 - Always apply voltage and current signals to each terminal that are within levels indicated within this manual. Otherwise, damage to the softstarter may result.
-

1. INTRODUCTION

1.1. Code Description

EXAMPLE

CODE: SS70275.6B

SS7	0275		.6		B	
SS7 Series	Output Current		Input Voltage		Internal Bypass	
0275	275A	-	230-500V	-	NO Internal Bypass	
0330	330A	.6	690V	B	WITH Internal Bypass	
...	...					

1.2. Description of the Equipment

SS7 Series is the 1st LS Softstarter generation. It is a new electronic softstarter that integrates most advanced control systems to assure a perfect motor operation at any industrial application. Outstanding features:

➤ **Mounting simplicity and versatility.**

Its cabinet format provides a fast installation and easy access to power and control terminals.

All SS7 Series incorporate a unique and common control board for all power ratings.

➤ **Control flexibility.**

Commissioning is possible via local display unit or PC (PowerCOMS program).

It includes 2 analogue inputs and 5 digital inputs, 3 output relays and 1 analogue output, to provide user with plenty of control possibilities.

RS232/RS485 serial communications are built-in: compatible with communication protocols Modbus, Profibus-DP, DeviceNet, N2-Metasys, etc.

➤ **INTERNAL BYPASS.**

The new SS7 models offer the Bypass contactors already built in, the need for additional external hardware will be significantly reduced with the result of consequent space savings (an additional electrical cabinet is not needed). Additionally it reduces installation time and the wiring verification, thus avoiding possible errors in external wiring.

Also, heat dissipation during operation is much less, which effects the corresponding saving in ventilation components in the implemented electrical cabinets. The current measurement of the softstarter will not suffer any change and the internal protections will be completely active, thus ensuring the motor protection all the time.

The internal bypass is automatically switched on after the acceleration has been finished, bridging the internal SCRs but without interrupting the normal operation of the softstarter and the motor.

At the end, the connection of the equipment is easy, safe and effective.



2. INSTALLATION AND CONNECTION

2.1. Environmental Conditions

The maximum ambient/working temperature for the SS7 is 45°C. The SS7 can be operated in a higher ambient temperature of up to 50°C by de-rating the soft starter by 2% for every degree over 45°C.

2.2. Degree of Protection

The SS7 soft starter ingress protection is IP20. This means that the soft starter is protected against finger contact with hazardous or moving parts inside the enclosure, and protection of against ingress of foreign objects with a diameter greater than 12mm.

2.3. Installation of the Softstarter

The SS7 soft starter is designed for vertical mounting.

Input bus bars are located in the top and motor bus bars must be connected at the bottom, except for models SS70009 to SS70090 where both, input and output must be connected at the bottom.

To improve heat dissipation, it is recommended to mount the soft starter on a metal gear plate.

In case of units are installed inside a cabinet, it is required to calculate the corresponding ventilation.

When installed within a cabinet, proper ventilation is to be provided. A minimum of 40mm side clearance and 150mm top and bottom distance is to be kept between soft starters and or side of the enclosure.

Do not install SS7 above any heat source, unless heat airflow is forced out of the cabinet.

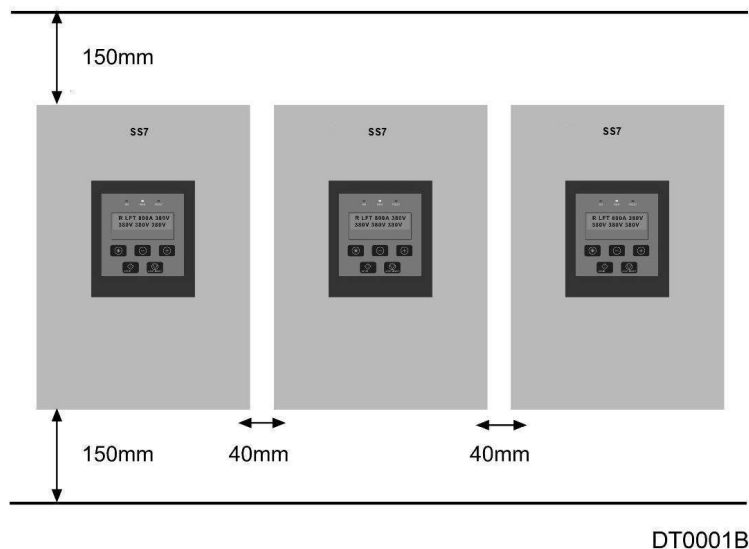

Figure 2.1 Installation and minimum distance between SS7 units

2.4. Power Loss Dissipation

The SS7 has a power loss of 3 watts per amp. For example this means that a SS70210 has a power loss of 630 watts at full load.

2.5. Power Connections and Control Wiring

2.5.1. Power Connections

Most electrical wiring regulations require a mains isolator on solid state equipment. The SS7 falls in to this category. This is to ensure there is an air break in the circuit as semiconductors cannot be relied upon to be safe isolation. There are many choices, the most common are thermal magnetic protection with a trip coil in conjunction with a contactor.

Magnetic protection is required to protect the SS7 from damage due in the event of a short circuit within the SS7 or on the output cabling or motor. When faster protection is desired, semiconductor fuses are recommended. The fuses should be mounted as close to the SS7 as possible. Power factor correction capacitors must not be connected after the fuses or on the output of the SS7.

The SS7 protects the motor with electronic overload sensing, so an external overload relay is not necessary. If multiple motors are connected, separate overloads are required for each motor.

An isolator can be fitted after the SS7 but is recommended for off load use only. Whilst a motor isolator is not necessary for the operation of the SS7, site standards or electrical wiring regulations may require this to be installed.

If a contactor is to be fitted, one of the SS7 output relays can be used to energise this on receiving an external start signal. (G7.1 Relay 1 = 11 Instantaneous).

Note: It is absolutely necessary that the installer guarantees the correct observance of the law and the regulations that are in force in those countries or areas where this device is going to be installed.

▪ Recommended Configuration

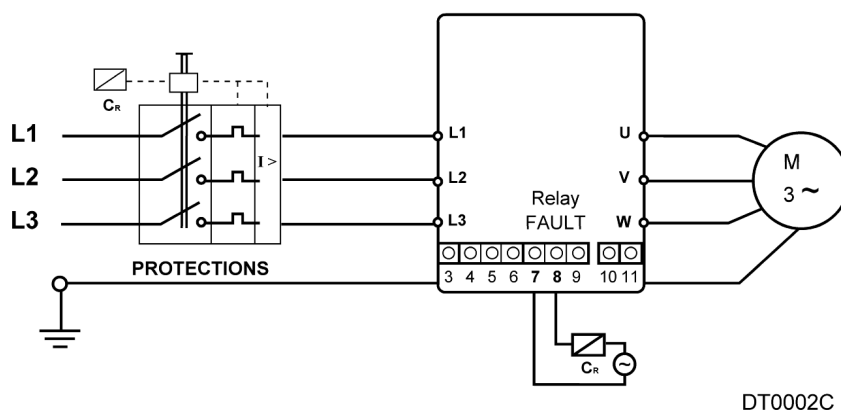

Figure 2.2 Recommended power wiring

Note: RELAY 3 (Terminals 7 and 8) configured as GENERAL FAULT >> G7.3= 09

▪ Configuration with Supply Contactor

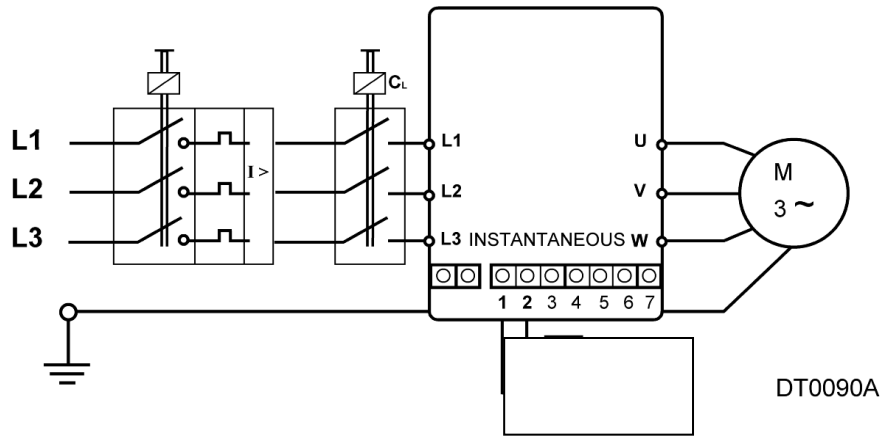

Figure 2.3 Line Contactor (CL) configuration

Note: RELAY 1 (Terminals 1 and 2) configured as INSTANTANEOUS >> G7.1= 14

▪ External Bypass Configuration

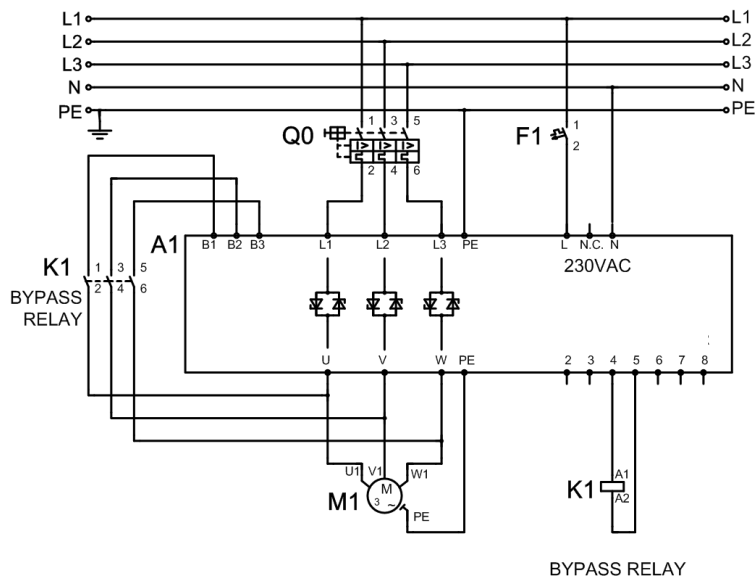

Figure 2.4 Power wiring configuration with External Bypass

Note: RELAY 2 (Terminals 4 and 5) must be configured as BYPASS / REACT >> G7.2= 15
Bypass contactor can be AC1 category.

▪ Internal Bypass Configuration

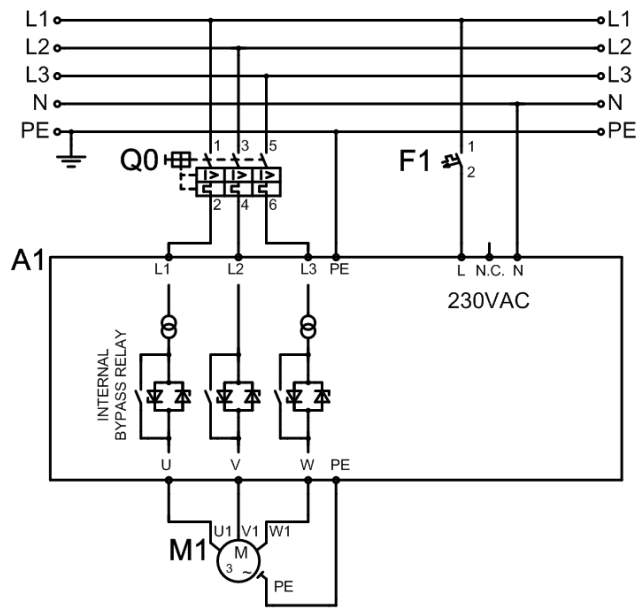

Figure 2.5 Power wiring configuration with Internal Bypass

Note: RELAY 2 (Terminals 4 and 5) is reserved for the activation of the Internal Bypass. It is configured as BYPASS / REACT >> G7.2= 15
Bypass contactor can be AC1 category.

▪ Configuration for compensation capacitors.

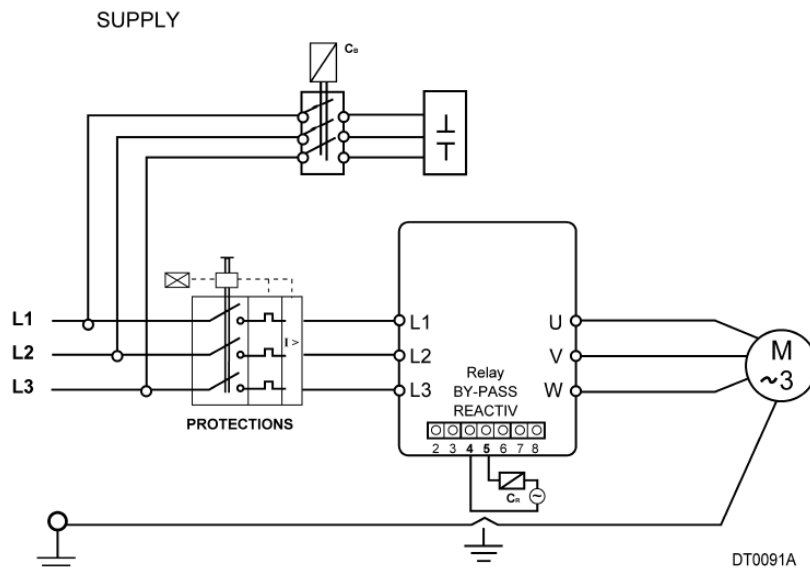

Figure 2.6 Configuration for compensation capacitors

Note: RELAY 2 (Terminals 4 and 5) must be configured as BYPASS / REACT >> G7.2= 15
To avoid damages do not connect capacitors at the output of the SS7.
This circuitry is only valid if compensation capacitors are operating for the motor connected to the SS7.

2.5.2. Control Wiring

For further information about control terminals, see section '7 CONNECTION TERMINALS'.

▪ STANDARD CONTROL WIRING Configuration

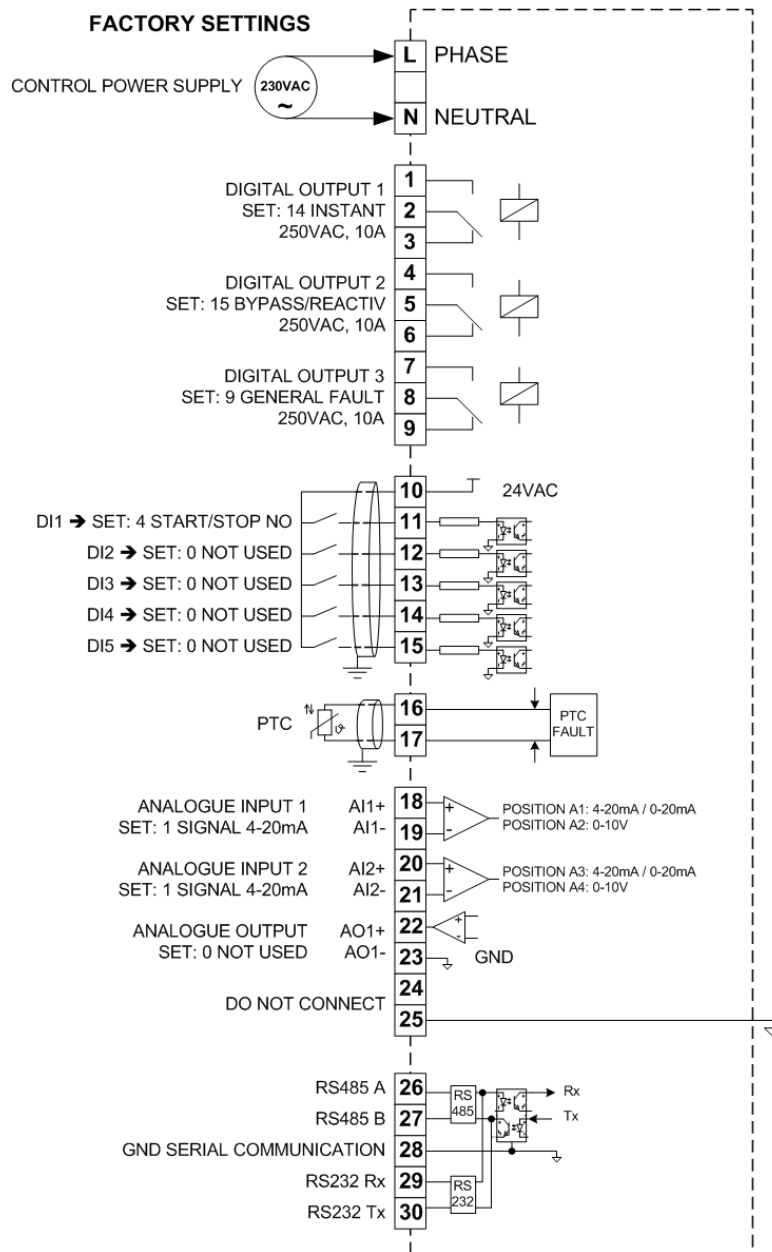

Figure 2.7 Control wiring for standard equipment

Note:

- Wiring distance
Control wiring should not be run in parallel with power input or output cables to the motor. There should be a minimum distance of 300mm between power and control cables, and should be crossed at right angles.
- Input and Outputs
All signals do need to be screened when running in parallel with power cables.

▪ Configuration of CONTROL WIRING WITH INTERNAL BYPASS

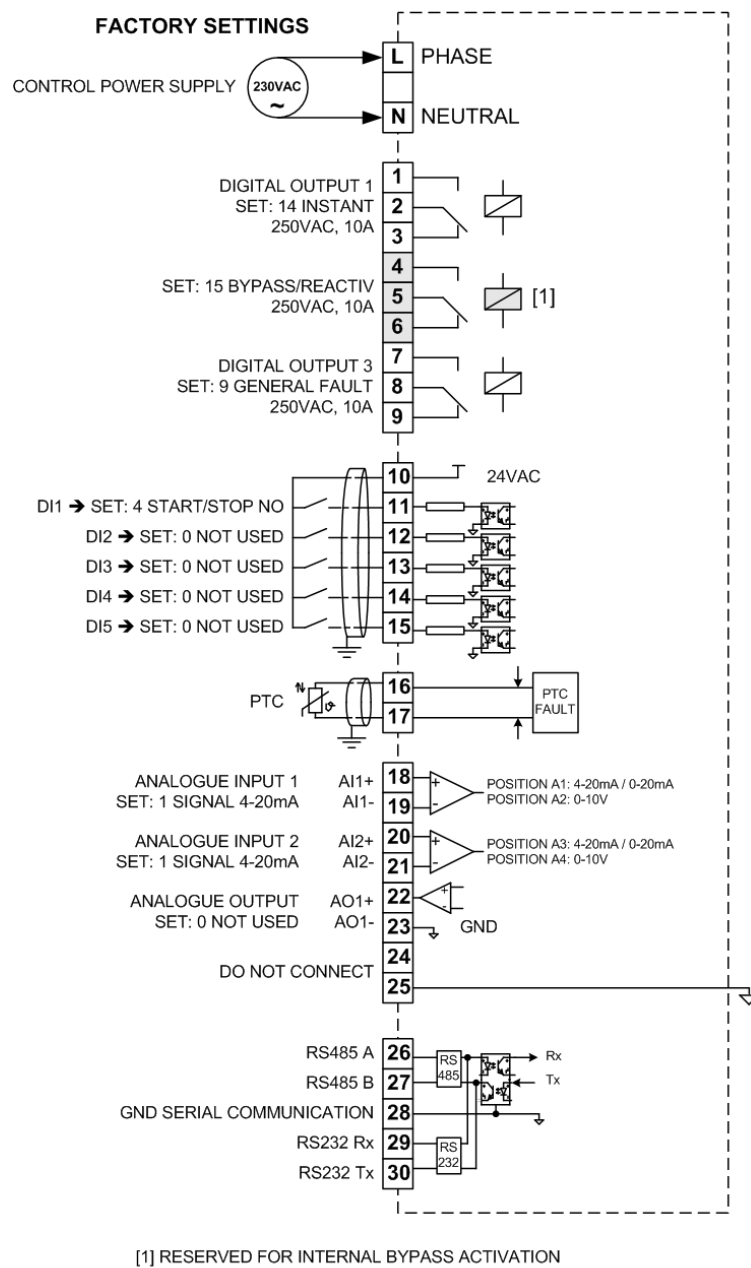

Figure 2.8 Control wiring for equipment with Internal Bypass

Note:

- Wiring distance
Control wiring should not be run in parallel with power input or output cables to the motor. There should be a minimum distance of 300mm between power and control cables, and should be crossed at right angles.
- Input and Outputs
All signals do need to be screened when running in parallel with power cables.

2.6. Considerations before commissioning the SS7 Softstarter

1. Check for foreign objects in the SS7 cabinet – particularly which left there from installation.
2. Check that the control board supply (L - N, 230VAC \pm 10%) is connected.
3. Check that the power supply is connected to the terminals L1, L2, L3 and the motor is connected to the terminals U, V, W. Confirm that the supply is according to the SS7 specifications. The motor current should not exceed the SS7 rating.
4. Check all control wiring, close SS7 cabinet and ensure the installation is electrically safe and that it is safe to run the motor.
5. It is recommended that all digital inputs are disconnected before applying voltage to the SS7 for the first time to prevent accidentally starting the motor. It is also recommended not to apply main voltage (3ph~) before commissioning the softstarter.

Note: SS7 Softstarter are configured with START, STOP, RESET from keypad by default.

6. Digital input status can be checked through screen **G0: DIG INPUT= X 0 0 0 0 F**.

X indicates this digital input is on, **0** indicates the digital input is off.

K indicates PTC input is not active. **F** indicates PTC input is active.

As default, the digital inputs are disabled G6.1 OPER MODE=1 (LOCAL). This means that the SS7 start and stop can only be controlled via the display unit pushbuttons.

7. The default configuration for the digital outputs is as follows:

Relay 1: Instantaneous (**Switch ON** = SS7 accelerates and **Switch OFF**= Deceleration of the SS7 is finished).

Relay 2: Bypass (**Switch ON** at end of ramp up and **Switch OFF** at start of ramp down).

Relay 3: Fault (**Energized** on fault conditions).

8. Ensure the stop circuit is open before configuring the SS7 to work in 3-wire mode.
9. Set the motor (rated) nameplate and start/stop parameters, protection and user parameters.
10. Set jumpers as follows:

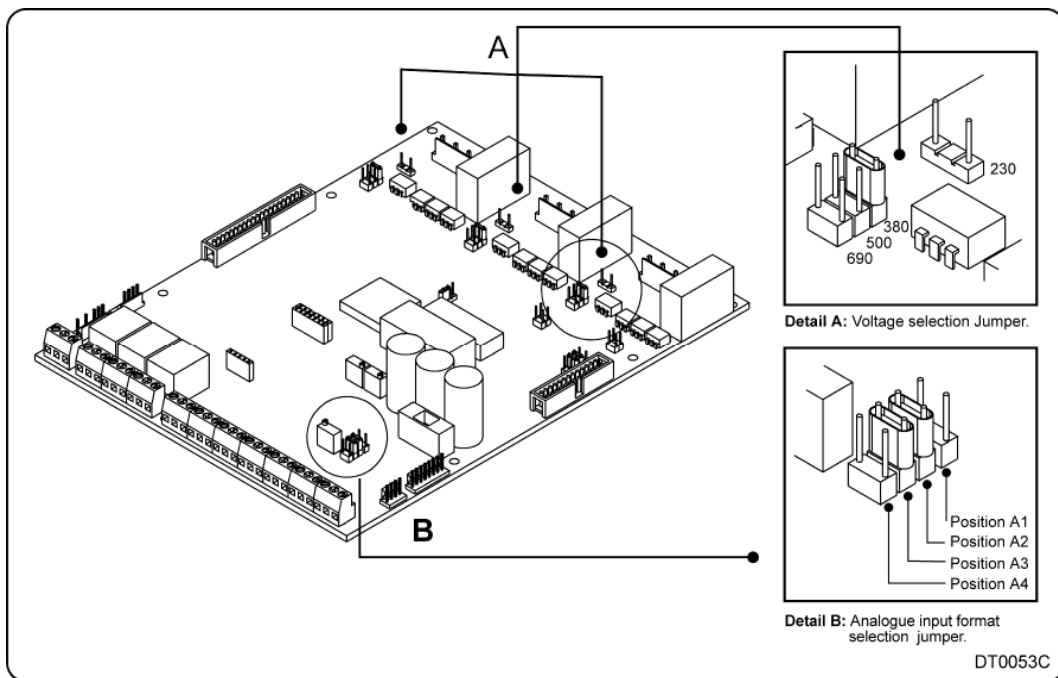

Figure 2.7 Jumpers setting

DETAIL A: VOLTAGE SELECTION JUMPER

Description	Select motor voltage.
Function	Set input supply voltage.
Adjustment	Position 1: 230V Position 2: 400V Position 3: 500V Position 4: 690V

Note: 230V/400V/500V soft starter use control board with reference E001.
690V soft starter use control board with reference E002.

DETAIL B ANALOGUE INPUT FORMAT SELECTION JUMPER

Description	Select Analogue input formats.
Default value	A1= (0-10V) A12= (0-20mA)
Function	Set Analogue input operating formats.
Adjustment	Position A1: 0-20mA/ 4-20mA (Analogue input 1). Position A2: 0-10V (Analogue input 1). Position A3: 0-20mA/ 4-20mA (Analogue input 2). Position A4: 0-10V (Analogue input 2).

Note: In order to select the analogue input, you must only configure the jumper in the corresponding position.

3. POWER RANGE

3.1. SS7 Standard Softstarter

FRAME	CODE	Rated I(A)	Motor Power (kW)			
			230V	400V	440V	500V
1	SS70009	9	2	4	5	5,5
	SS70017	17	5	7	9	11
	SS70030	30	9	15	18,5	18,5
	SS70045	45	14	22	25	30
	SS70060	60	18	30	35	40
	SS70075	75	22	37	45	50
	SS70090	90	25	45	55	65
2	SS70110	110	35	55	65	80
	SS70145	145	45	75	90	100
	SS70170	170	50	90	110	115
	SS70210	210	65	110	120	150
3	SS70250	250	75	132	160	180
	SS70275	275	85	150	170	200
	SS70330	330	100	185	200	220
	SS70370	370	115	200	220	257
	SS70460	460	145	250	270	315
4	SS70580	580	185	315	375	415
	SS70650	650	200	355	425	460
	SS70800	800	250	450	500	560
	SS70900	900	280	500	560	630
	SS71000	1000	322	560	616	700
5	SS71200	1250	400	710	850	900
	SS71500	1500	500	800	900	1100

Table 3.1 SS7 Standard Softstarter. Power and current value table for 230-500VAC

FRAME	CODE	Rated I(A)	Motor Power (kW) at 690V
1	SS70009.6	9	7,5
	SS70017.6	17	15
	SS70030.6	30	30
	SS70045.6	45	45
	SS70060.6	60	60
	SS70075.6	75	75
	SS70090.6	90	90
2	SS70110.6	110	110
	SS70145.6	145	140
	SS70170.6	170	160
	SS70210.6	210	200
3	SS70250.6	250	230
	SS70275.6	275	250
	SS70330.6	330	315
	SS70370.6	370	355
	SS70460.6	460	450
4	SS70580.6	580	560
	SS70650.6	650	630
	SS70800.6	800	800
	SS70900.6	900	900
	SS71000.6	1000	960
5	SS71200.6	1250	1250
	SS71500.6	1500	1500

Table 3.2 SS7 Standard Softstarter. Power and current value table for 690VAC

Power Ratings for 230-500VAC (-20% to +10%)

NOTES:

- The values of the tables are valid for 4-pole AC motors.
- For current values which are not in accordance with the values in this tables, please contact with LS.
- For higher power ratings, contact with LS customer support.

Power Ratings for 690VAC (-20% to +10%)

NOTES:

- The values of the tables are valid for 4-pole AC motors.
- For current values which are not in accordance with the values in this tables, please contact with LS.
- For higher power ratings, contact with LS customer support.

3.2. SS7 Softstarter with Internal Bypass

The norm IEC60947-4-2 describes classification for Electronic Softstarters.

According to this information, there are two utilisation categories for the Electronics Softstarters, described as follow:

- AC53a: Softstarters which support the nominal current through the SCRs during continuous operation.
- AC53b: Softstarters which support the starting current through the SCRs during the starting while the SCRs will be bypassed during steady status.

Basically, the capacity limitation of Softstarters is mainly thermal limitation. It is important to consider that there are five different factors which will affect to the internal temperature of thyristors:

- a) Starting Time
- b) Starting Current.
- c) Ambient Temperature
- d) Time at OFF status
- e) Number of Startings per Hour.

EXAMPLE

110	:	AC53b	4.5	-	30	:	330
①		②	③		④		⑤

- ① Rated Current of the Softstarter under the described conditions: In, (110 Amps)
- ② The thyristors will be bypassed.
- ③ Starting Current, as multiple of the nominal current (In), that means: 4.5xIn
- ④ Starting Time, in seconds, (30s)
- ⑤ Seconds between the end of starting and the beginning of next starting (10 startings per hour)

FRAME	CODE	AC53b 3.0-30:330		AC53b 4.0-30:330		AC53b 4.5-30:330	
		Rated I(A)	Motor Pow. (kW) at 400VAC	Rated I(A)	Motor Pow. (kW) at 400VAC	Rated I(A)	Motor Pow. (kW) at 400VAC
1	SS70009B	14	7,5	10	5,5	9	4
	SS70017B	26	15	19	11	17	7,5
	SS70030B	45	22	34	18,5	30	15
	SS70045B	68	37	51	30	45	22
	SS70060B	90	45	68	37	60	30
	SS70075B	113	55	85	45	75	37
	SS70090B	135	75	101	55	90	45
2	SS70110B	165	90	140	75	110	55
	SS70145B	218	110	164	90	145	75
	SS70170B	255	150	192	110	170	90
	SS70210B	315	185	237	132	210	110
	SS70250B	375	200	281	150	250	132
3	SS70275B	412	220	310	185	275	150
	SS70330B	495	280	370	200	330	185
	SS70370B	555	315	416	220	370	200
4	SS70460B	690	400	518	280	460	250
	SS70580B	870	450	650	355	580	315
	SS70650B	975	500	731	400	650	355
	SS70800B	1200	630	900	500	800	450

Table 3.3 SS7 Softstarter with Internal Bypass. Power and current value table for 400VAC

Power Ratings for 400VAC (-20% to +10%)

NOTE:

- Rated powers and currents at 400VAC (-20% to +10%) for motors of 1500rpm.

FRAME	CODE	AC53b 3.0-30:330		AC53b 4.0-30:330		AC53b 4.5-30:330	
		Rated I(A)	Motor Pow. (kW) at 500VAC	Rated I(A)	Motor Pow. (kW) at 500VAC	Rated I(A)	Motor Pow. (kW) at 500VAC
1	SS70009B	14	11	10	7,5	9	5,5
	SS70017B	26	18,5	19	15	17	11
	SS70030B	45	30	34	22	30	18,5
	SS70045B	68	45	51	37	45	30
	SS70060B	90	55	68	45	60	37
	SS70075B	113	75	85	55	75	45
	SS70090B	135	90	101	75	90	55
2	SS70110B	165	110	140	90	110	75
	SS70145B	218	150	164	110	145	90
	SS70170B	255	185	192	132	170	110
	SS70210B	315	220	237	185	210	150
	SS70250B	375	250	281	200	250	185
3	SS70275B	412	280	310	220	275	200
	SS70330B	495	355	370	250	330	220
	SS70370B	555	400	416	280	370	250
	SS70460B	690	500	518	355	460	315
4	SS70580B	870	560	650	450	580	400
	SS70650B	975	630	731	500	650	450
	SS70800B	1200	710	900	630	800	560

Table 3.4 SS7 Softstarter with Internal Bypass. Rated power and current value table for 500VAC

Power Ratings for 500VAC (-20% to +10%)

NOTE:

- Rated power and currents at 500VAC (-20% to +10%) for motors of 1500rpm.

FRAME	CODE	AC53b 3.0-30:330		AC53b 4.0-30:330		AC53b 4.5-30:330	
		Rated I(A)	Motor Pow. (kW) at 690VAC	Rated I(A)	Motor Pow. (kW) at 690VAC	Rated I(A)	Motor Pow. (kW) at 690VAC
1	SS70009.6B	14	15	10	11	9	7,5
	SS70017.6B	26	22	19	18,5	17	15
	SS70030.6B	45	45	34	37	30	30
	SS70045.6B	68	75	51	55	45	45
	SS70060.6B	90	90	68	75	60	55
	SS70075.6B	113	110	85	90	75	75
	SS70090.6B	135	132	101	110	90	90
2	SS70110.6B	165	150	124	132	110	110
	SS70145.6B	218	200	164	150	145	132
	SS70170.6B	255	250	192	200	170	150
	SS70210.6B	315	315	237	220	210	200
	SS70250.6B	375	355	281	250	250	220
3	SS70275.6B	412	400	310	315	275	250
	SS70330.6B	495	450	370	355	330	315
	SS70370.6B	555	500	416	400	370	355
	SS70460.6B	690	630	518	500	460	450
4	SS70580.6B	870	800	650	630	580	560
	SS70650.6B	975	900	731	710	650	630
	SS70800.6B	1200	1000	900	900	800	800

Table 3.5 SS7 Softstarter with Internal Bypass. Rated power and current value table for 690VAC

Power Ratings for 690VAC (-20% to +10%)

NOTE:

- Rated power and currents at 690VAC (-20% to +10%) for motors of 1500rpm.

4. TECHNICAL CHARACTERISTICS

INPUT	Input voltage	(3-Phase) 230-500V (-20% to +10%) (3-Phase) 690V (-20% to +10%)
	Supply frequency	47 to 62 Hz
	Control voltage	230VAC \pm 10%, others under demand
OUTPUT	Output voltage	0 to 100% Input voltage
	Output frequency	Same as the input
	Efficiency at full load	>99%
ENVIRONMENTAL PROTECTION	Ambient temperature	Minimum: -10°C / Maximum: +50°C
	Storage temperature	0°C to +70°C
	Ambient humidity	<95%, non-condensing
	Altitude de-rating	>1000m, 1% per 100m; 3000m max.
	Protection degree	IP20
Degree of Pollution	Degree of Pollution 3	
MOTOR PROTECTIONS	Input phase missing	
	High voltage	
	Low input voltage	
	Starting current limit	
	Rotor locked	
	Motor overload (thermal model)	
	Underload	
	Phase unbalance	
	Motor overtemperature (PTC, normal status 150R-2K7)	
	Shearpin current	
Max. number of startings/hour		
SOFTSTARTER PROTECTIONS	Thyristor fault	
	Softstarter overtemperature	
ADJUSTMENTS	Torque surge	
	Initial torque	
	Initial torque par	
	Acceleration time	
	Current limit: 1 to 5·In	
	Overload: 0.8 to 1.2·In, Overload slope: 0 to 10	
	Deceleration time / Freewheel stop	
	DC Braking	
	Slow speed (1/7 fundamental frequency)	
	Dual setting	
	Number of allowed startings/hour	
	Torque control	
Water hammer surge control stop		
INPUT SIGNALS	2 Analogue Inputs programmable in voltage or current (0-10V, 0-20mA or 4-20mA)	
	5 programmable Digital Inputs	
	1 PTC input	
OUTPUT SIGNALS	1 Analogue Output 0-20mA or 4-20mA	
	3 changeover Output Relays (10A, 250VAC non inductive)	
SERIAL COMMUNICATIONS	Physical level RS232 / RS485	
	Modbus communication industrial protocol	
	Profibus, DeviceNet and Johnson Control (Metasys) as option	
DISPLAYED INFORMATION	Phase current	
	Supply voltage	
	Relays status	
	Digital inputs / PTC status	
	Analogue inputs value	
	Analogue output value	
	Overload status	
	Motor supply frequency	
	Motor power factor	
	Developed power. Motor shaft torque	
Fault history (5 most recent faults)		
CONTROL SOURCES	Local via keypad	
	Remote via digital inputs	
	Serial Communications (Modbus, RS232/RS485)	
LED'S INDICATIONS	LED1 Green, voltage present on control board	
	LED2 Orange. Blinking, motor accelerating/decelerating. On, motor running	
	LED3 Red, Fault present	
CERTIFICATION	CE, UL, cUL, cTick	

5. DIMENSIONS

5.1. Dimensions for Frames 1 and 2

FRAME	REFERENCE	DIMENSIONS (mm)							WEIGHT (kg)
		H1	H2	H3	W1	W2	D	Y1	
1	SS70009 – SS70090	414	396	347	226	120	230	-	11,6
	SS70009.6 – SS70090.6								11,6
	SS70009B – SS70090B								12,1
	SS70009.6B – SS70090.6B								12,1
2	SS70110 – SS70250	523	506	457	314	160	260	-	19
	SS70110.6 – SS70250.6								19
	SS70110B – SS70250B								21
	SS70110.6B – SS70250.6B								21

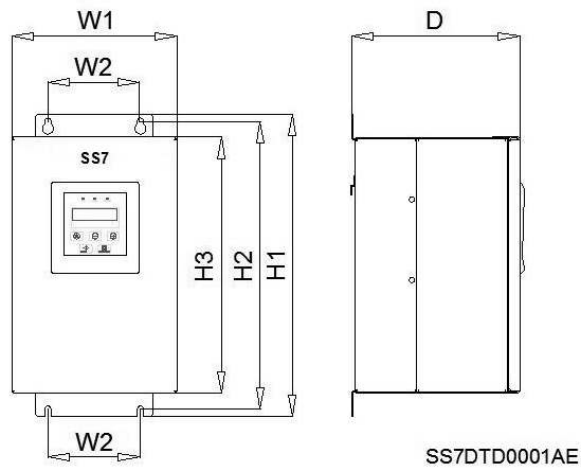

Figure 5.1 Dimensions for Frame 1

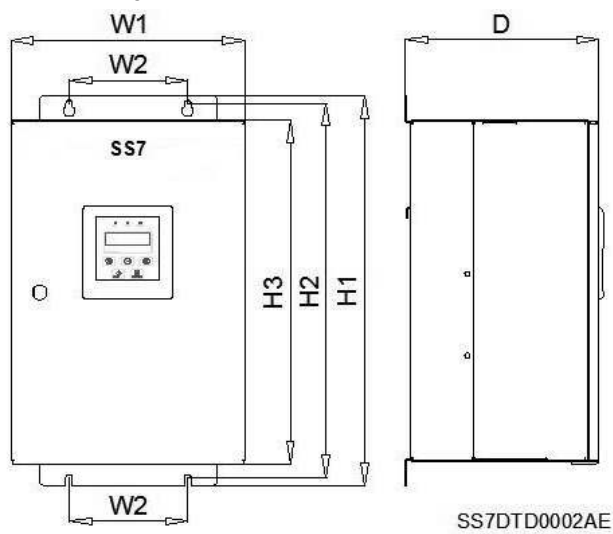

Figure 5.2 Dimensions for Frame 2

5.2. Dimensions for Frames 3 and 4

FRAME	REFERENCE	DIMENSIONS (mm)							WEIGHT (kg)
		H1	H2	H3	W1	W2	D	Y1	
3	SS70275 – SS70460	791	771,5	705	580	349	309	-	53,6
	SS70275.6 – SS70460.6								53,6
	SS70275B – SS70460B								60,6
	SS70275.6B – SS70460.6B								60,6
4	SS70580 – SS71000	926	906,5	840	640	480	324	-	77,6
	SS70580.6 – SS71000.6								77,6
	SS70580B – SS71000B								86,6
	SS70580.6B – SS71000.6B								86,6

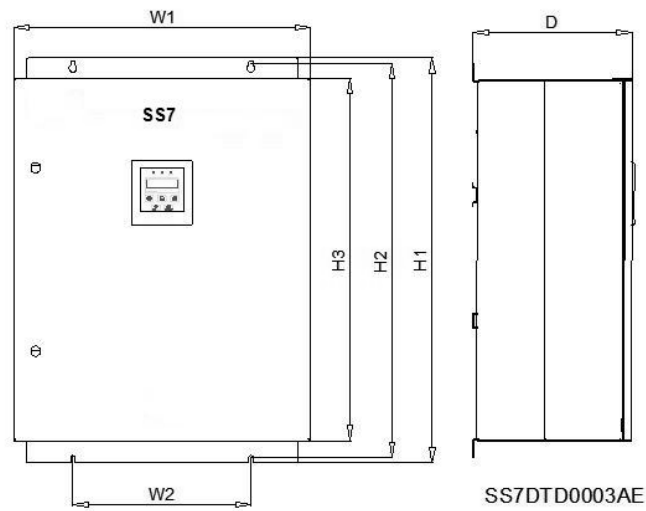

Figure 5.3 Dimensions for Frame 3

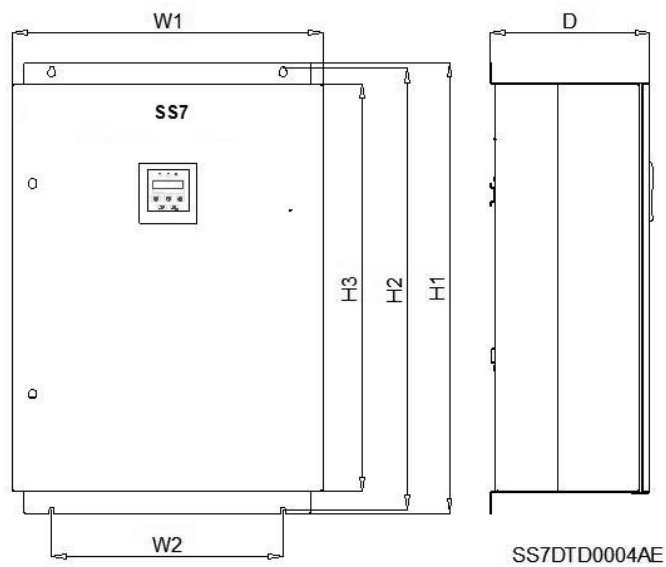

Figure 5.4 Dimensions for Frame 4

5.3. Dimensions for Frame 5

FRAME	REFERENCE	DIMENSIONS (mm)							WEIGHT (kg)
		H1	H2	H3	W1	W2	D	Y1	
5	SS71200 – SS71500	1552	1533	1400	1084	928	475	135	300,0
	300,0								

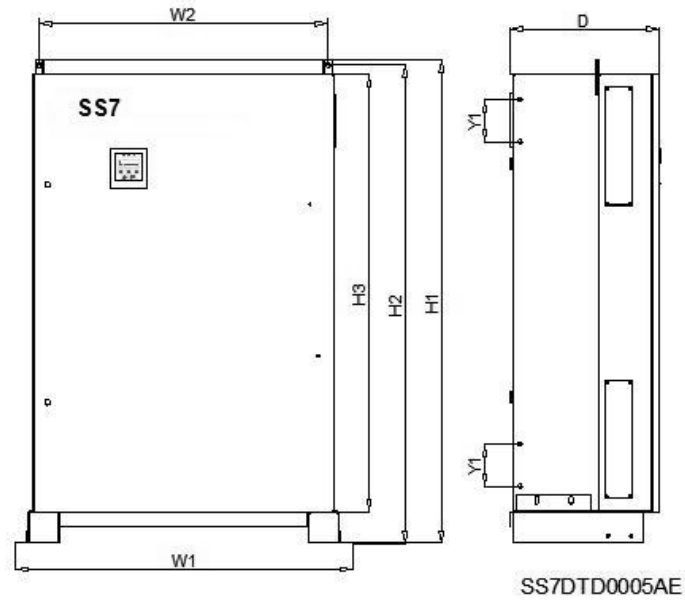

Figure 5.5 Dimensions for Frame 5

6. CE CONFORMITY DECLARATION

The Company:

Name: **LS Industrial System Co., Ltd.**
 Address: LS Tower, Hogye-dong, Dongan-gu,
 Anyang-si, Gyeonggi-do 1026-6, Korea

Declares under its own responsibility, that the product:

Electronic Softstarters for A.C. motors

Brand: LS Industrial System Co., Ltd.
Model name: SS7 Series

Manufacturer: **LS Industrial Systems Europe B.V. Amsterdam, Netherland**
 Address: 1st. Floor, Tupolevlaan 48, 1119NZ Schiphol-Rijk, The Netherlands
 Telephone: 31-20-654-1420
 Fax: 31-20-654-1429

Is in conformity with the following European Directives:

References	Title
2006/95/CE	Electrical Material intended to be used with certain limits of voltage
2004/108/CE	Electromagnetic Compatibility

References of the harmonized technical norms applied under the Low Voltage Directive:

References	Title
EN 60947-4-1:2001 A1:2002/A2:2005	Low-voltage switchgear and controlgear -- Part 4-1: Contactors and motor-starters - Electromechanical contactors and motor-starters.
EN 60947-4-2:2000 A1:2002/A2:2006	Low-voltage switchgear and controlgear -- Part 4-2: Contactors and motor-starters -- A.C. semiconductor motor controllers and starters.

References of the harmonized technical norms applied under the Electromagnetic Compatibility Directive:

References	Title
EN 60947-4-2:2000 A1:2002/A2:2006	Low-voltage switchgear and controlgear -- Part 4-2: Contactors and motor-starters -- A.C. semiconductor motor controllers and starters.

Choan, Chungnam, Korea

Mr. In Sik Choi / General Manager

7. CONNECTION TERMINALS

The next figure provides the electrical specification of all SS7 control inputs and outputs. Each input and output is individually described below:

- Analogue and digital inputs / outputs.
- Serial Communication (RS232/RS485).

7.1. Control Connection Drawing

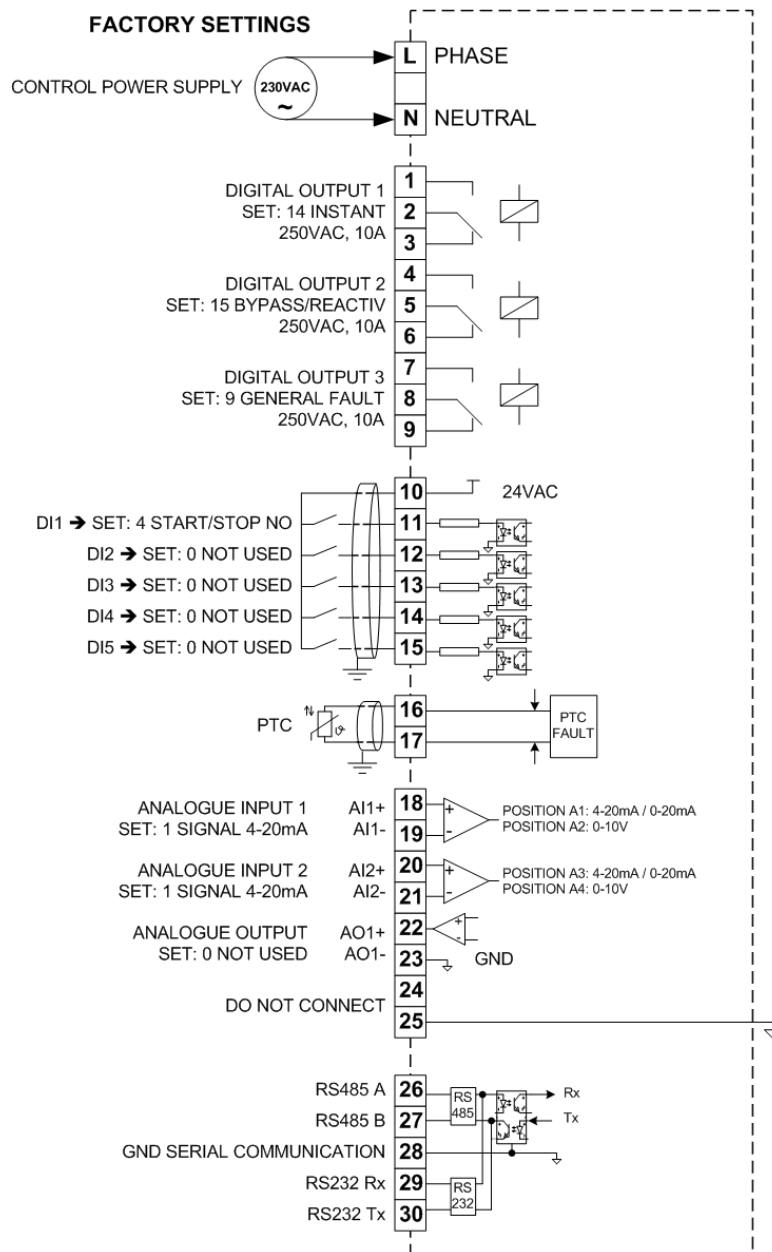

Figure 7.1 Connection terminals description (SS7 Standard Softstarter)

7.2. Terminal Description

Control board supply voltage

Input terminals for control board supply voltage (230V +/-10%). Other voltage ratings are available on demand.

Note that the unused terminal between L and N is purely to ensure electrical clearances.

Terminals T1 to T9 / Programmable Output Relays

Selection of their function is made through Group 7 OUTPUTS. Avoid settings that cause relays to switch excessively as this will reduce their life expectancy.

The maximum allowable ratings for the relay outputs are 250V/AC / 10A or 30V/DC 10A.

Terminal T10 / 24VAC for Digital Inputs

This terminal provides the 24V supply for the 5 digital inputs at terminals T11 to T15. This terminal is fuse (E0141) protected (250V,1A) for overload/short-circuit protection. The fuse is located at the bottom right of the control board.

Terminals T11 to T15 / Digital Inputs

The function of the digital inputs can be programmed from the keyboard, at the group G6 INPUT.

Terminals T16 and T17 / Motor PTC Input

If the PTC value is $\geq 1K7$, a fault is generated and will be not reset until the resistance value is below 260 ohms. On the other hand, if this value is below 100ohm, a fault is also generated and will be not reset until the resistance value is ≥ 160 ohms.

Terminals T18 to T21 / Analogue Inputs

The function of the Analogue inputs can be programmed from the keyboard at the group G6 Inputs. To select 4-20mA or 0-10V you have to switch the jumpers as described below. See section '2.6 Considerations before Commissioning the SS7 Softstarters' for further information:

Analogue Input 1 (T18-T19)

Position A1: 0-20mA / 4-20mA.

Position A2: 0-10V

Analogue Input 2 (T20-T21)

Position A3: 0-20mA / 4-20mA.

Position A4: 0-10V

Terminals T22 and T23 / Analogue Output

This Analogue output can have its format and source configured. Formats can be 0-10V, 0-20mA or 4-20mA. Configuration is done from group G7 OUTPUTS.

Terminal T25 / Analogue 0V connection

This terminal is 0V connection for analogue signals.

Terminals T26 to T30 / RS485/RS232

These terminals are provided for serial communications connection.

Serial communications are optically isolated from SS7 control electronics in order to increase the immunity from noise in hostile installation sites.

8. DISPLAY UNIT AND KEYPAD OPERATION

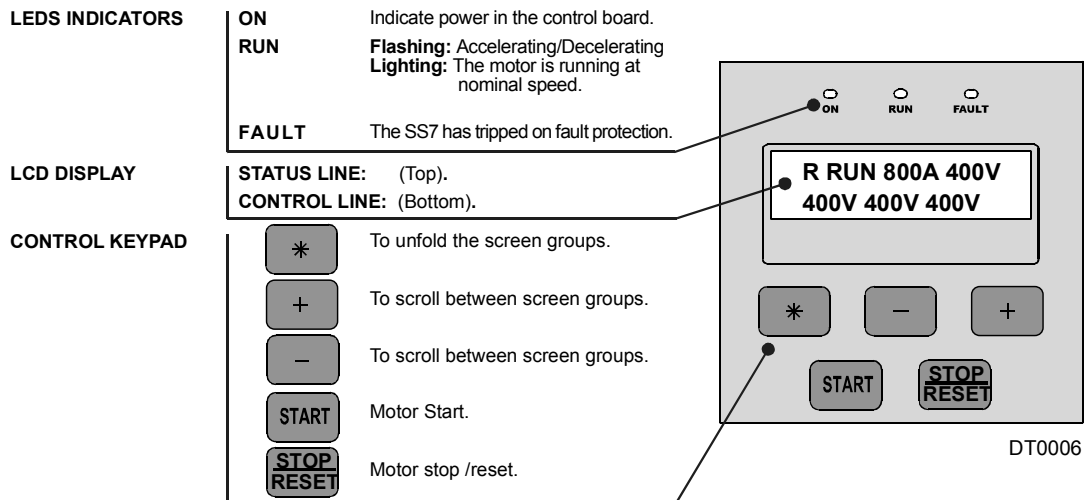

Figure 8.1 Display Unit

8.1. LCD Display

The SS7 has a sixteen character by two line (16x2) LCD display. Each line has a different function:

- **STATUS LINE (Upper line):**
It is always present and shows SS7 status, phase current and supply voltage.
- **CONTROL LINE (Lower line):**
It is used to view and/or adjust the SS7 commissioning parameters.

8.2. Control Keys

- **+** and **-** These keys are used to scroll between groups.
- ***** This can be used to unfold a screen group.
- **+** and **-** Used to scroll between screens within the selected screen group.
- ***** and **+** or **-** Press at the same time to adjust the selected parameter.
- **-** Press to scroll back and return to screen group.

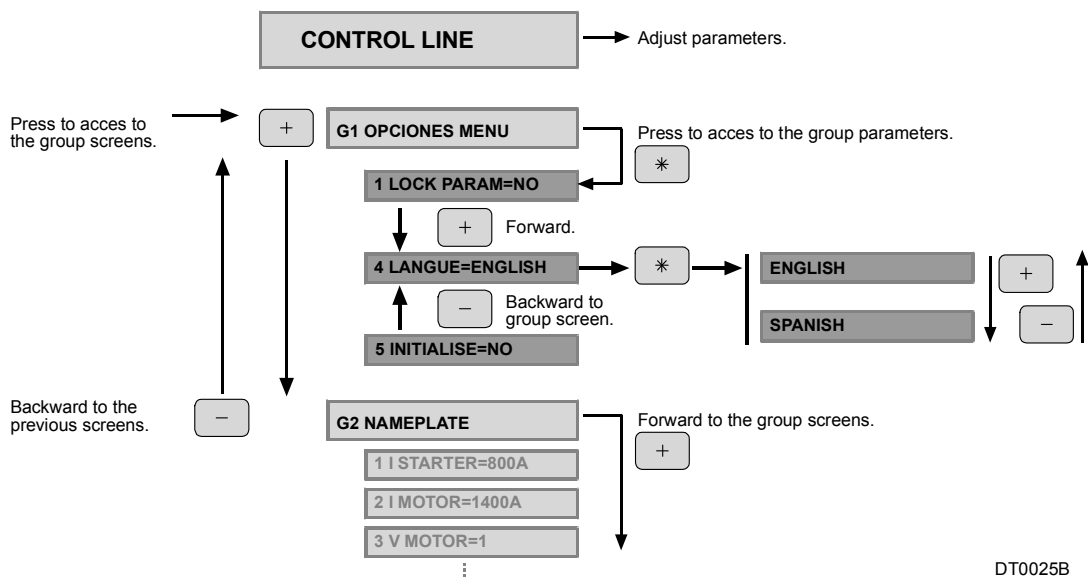

DT0025B

Figure 8.2 Programming example

8.3. Start and Stop-Reset / Slow Speed Buttons

These pushbuttons enable starting and stopping of the motor from the display unit and also running at slow speed:

- **START** Start and Slow Speed +.
- **STOP
RESET** Stop and Reset and Slow Speed -.

9. STATUS MESSAGES

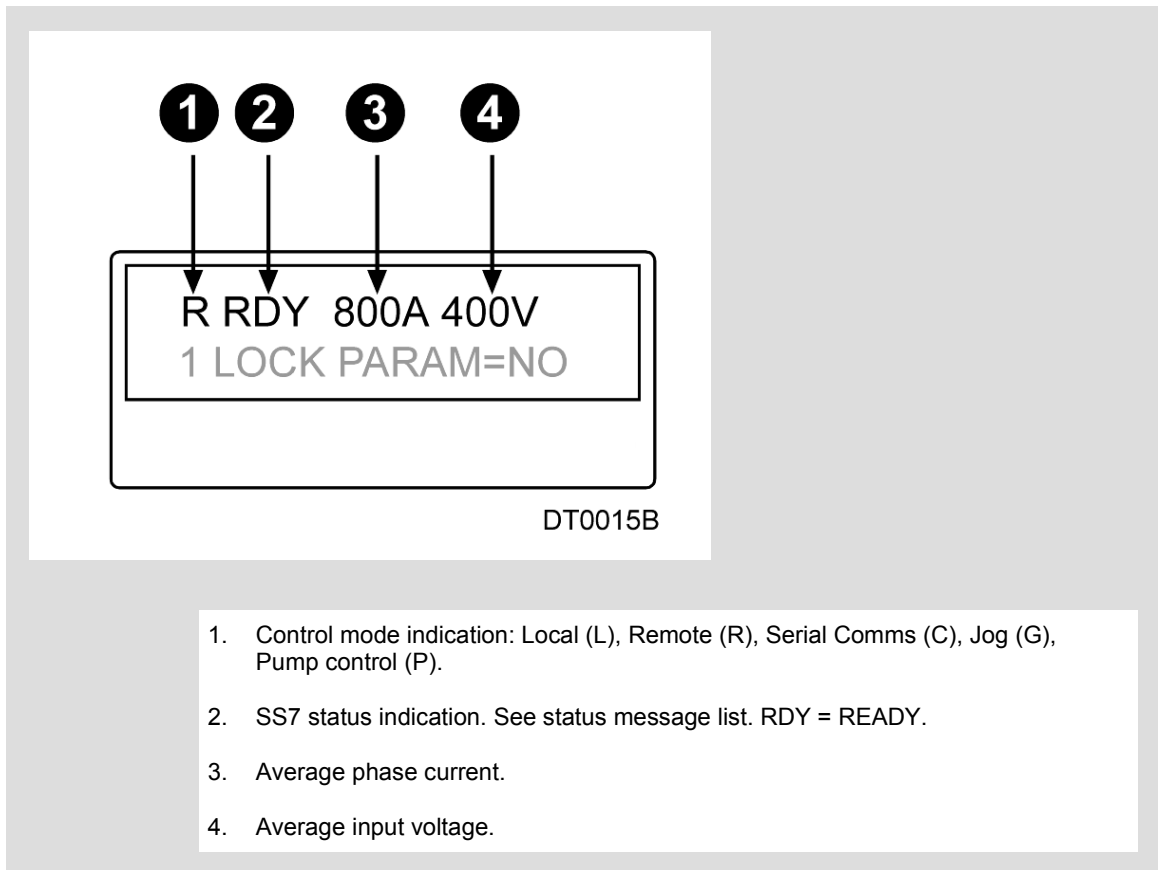

Figure 9.1 Display. Status messages

Display	Name	Description
RDY	READY	The SS7 is ready to run.
ITQ	INITIAL TORQUE	The SS7 is applying the Initial Torque specified at G4.4 Initial Torque for the time specified at G4.5 Initial Torque Time.
ACL	ACCELERATING	Motor is accelerating.
RUN	RUNNING	The motor runs at nominal Speed, after the acceleration ramp is finished (Output voltage = Input voltage).
DEC	DECELERATING	The Motor is decelerating.
HAM	HAMMER	Water Hammer algorithm is operating.
LS+	SLOW SPEED +	SS7 is applying Slow Speed + (CLOCKWISE).
LS-	SLOW SPEED -	SS7 is applying Slow Speed - (COUNTER-CLOCKWISE).
DCB	DC BRAKE	DC Brake current applied at the end of the ramp down.
UNV	UNDERVOLTAGE	Low mains supply.
OVV	OVERVOLTAGE	High mains supply.
OVL	OVERLOAD	Overload condition.
UDL	UNDERLOAD	Underload condition.
PTC	MOTOR PTC	Motor PTC fault.
OVT	SOFTSTARTER OVERTEMPERATURE	The temperature inside the softstarter is too high.

Display	Name	Description
SHP	SHEARPIN CURRENT	The shearpin function has switched off the softstarter.
ASY	ASYMMETRIC CURRENT	Asymmetric current at the motor.
FLT	FAULT	A fault has switched off the Softstarter.
STD	START DELAY	The SS7 delays the start signal set in screen G4.1 Start delay.
EXT	EXTERNAL FAULT	Fault status is active due to an external fault command through one of the digital inputs.
P/T	TORQUE PULSE	The SS7 is applying torque pulse set in screen G4.2 moment during the time set in screen G4.3.
ILT	CURRENT LIMIT	The SS7 has reached a maximum current level allowed in screen G4.7. Current limit.
HIP	HIGH PRESSURE	It warns during the time entered in screen G16.4.
LOP	LOW PRESSURE	It warns during the time entered in screen G16.5. and G16.6.
NOF	NO FLOW	It warns during the time entered in screen G16.7 and G16.8.
LWA	LOW WATER	It warns during the time entered in screen G16.9.

10. GENERAL INFORMATION SCREENS

The bottom line displays the General Information and parameter screens (G1 to G16).
The general information screens show information related to the motor and SS7 status:

Screen	Name / Description	Range	Units	Attribute	Function																	
800A 800A 800A	L1, L2, L3 phase current	0 to 9999	A	Read only	Phase current. Shows the instantaneous current of the three incoming phases.																	
380V 380V 380V	L1-L2, L2-L3, L1-L3 Line voltage	0 to 999	V	Read only	Supply voltage. Shows the line-to-line input voltage.																	
50Hz Cos=0.85	Supply frequency	0 to 99Hz	-	Read only	Shows the supply frequency and cos phi of the motor. Note: This screen is only visible while the motor is running.																	
	Motor phi cosine	0 to 1																				
450kW Pr=99%	Active power	1 to 900kW	-	Read only	The instantaneous kilowatts and percentage of nominal motor torque. Note: This screen is only visible while the motor is running.																	
	Motor torque	0 to 999%																				
RELAYS 1 2 3 0 0 0	Status of relay 1, 2, 3.	0 – Open X – Closed	-	Read only	Shows the relay status if the relays are energised (X) or de-energised (0).																	
DIG INPUT= 0 0 0 0 0 F	Digital inputs 1, 2, 3, 4, 5 & PTC status.	0 =open X =closed K = PTC ok F = fault in PTC wiring.	-	Read only	The first five digits refer to the digital inputs and the sixth is for the PTC temperature sensor. <table border="1" style="margin-left: auto; margin-right: auto;"> <thead> <tr> <th>Inputs</th> <th>Terminal</th> <th>Range</th> </tr> </thead> <tbody> <tr> <td>Digital Input 1</td> <td>T11</td> <td rowspan="5">0: open X: closed</td> </tr> <tr> <td>Digital Input 2</td> <td>T12</td> </tr> <tr> <td>Digital Input 3</td> <td>T13</td> </tr> <tr> <td>Digital Input 4</td> <td>T14</td> </tr> <tr> <td>Digital Input 5</td> <td>T15</td> </tr> <tr> <td>PTC Input</td> <td>T16-T17</td> <td>K: OK F: fault</td> </tr> </tbody> </table>	Inputs	Terminal	Range	Digital Input 1	T11	0: open X: closed	Digital Input 2	T12	Digital Input 3	T13	Digital Input 4	T14	Digital Input 5	T15	PTC Input	T16-T17	K: OK F: fault
Inputs	Terminal	Range																				
Digital Input 1	T11	0: open X: closed																				
Digital Input 2	T12																					
Digital Input 3	T13																					
Digital Input 4	T14																					
Digital Input 5	T15																					
PTC Input	T16-T17	K: OK F: fault																				
O/L STATUS=0%	Motor Overload status	0 to 100%	-	Read only	When the motor current is lower than the overload current set at G3.2, the overload status is 1%. As soon as the current increases above the overload current, the overload factor begins to increase, the more the difference is, the faster the overload factor grows, until this reaches 100%, when the soft starter will trip and show overload fault.																	
AI1=0.00mA = 0%	Analogue input 1 value, value in user units.	0 to 10V 4 to 20mA 0 to 20mA	V or mA User selectable units	Read only	Shows the value of analogue Input 1 (volts, mA) according to the option selected at G6.8, and the value in user units according to the option selected at G6.10 and with the scale selected at G6.9.																	
AI2=0.00mA = 0%	Analogue input 2 status, value in user units.	0 to 10V 4 to 20mA 0 to 20mA	V or mA User selectable units	Read only	Shows the value at the Analogue Input 2 (volts, mA) according to the option selected at G6.11, and the value in user units according to the option selected at G6.13 and with the scale selected at G6.12.																	
AO1=0.00mA =0%	Status of the Analogue Output 1	0 to 20mA 4 to 20mA	mA or %	Read only	Displays the absolute value of the Analogue output 1, in real units and percentage over the range of the Analogue output 1. The Analogue output should be related to the source selected at G7.4																	
S/W 2.1 H/W 2.0	Software and Hardware revision.	-	-	-	Displays the actual software (S/W) and hardware (H/W) revision.																	

11.PARAMETERS DESCRIPTION

All those parameters displayed in the SS7 are organised in various groups (G1 to G16). By pressing the “+” key it is possible to open each individual screen group.

11.1. Group 1 – G1: MENU OPTIONS

Screen	Name / Description	Range	Default Value	Function						
1 LOCK PARAM=NO	G1.1 / Lock parameters	YES NO	NO	If this function is active a password is required to be written in screen G1.2.						
2 PASSWORD= 0	G1.2 / Password	OFF, 0000 to 9999	0	Allows the commissioning user to set a password to protect against un-authorized modification of the parameters. Setting up: Once set to normal mode as described above, a password may be set up. Unfold screen Group 1 and scroll to screen 1; select: 1 LOCK PARAM=YES. PASSWORD=XXXX To unlock the soft starter parameters the following steps are necessary: Go to G1.1 1 LOCK PARAM= Yes and press (+).The screen 2 Password=xxxx appears, where the valid password must be entered.						
3 WRONG P/W=XXXX	G1.3 / Password recovery	000 to 9999	0000	This provides the required recovery information to unlock the soft starter, according to the expression: PASSWORD = (WRONG PW/2)-3						
4 LANGUE=ENGLISH	G1.4 / Selection of operating	ENGLISH ESPAÑOL DEUTSCH	ENGLISH	Determines the languages displayed by the SS7.						
5 INITIALISE=NO	G1.5 / Initialization	YES NO	NO	Initialise the SS7 parameters to default values.						
6 COMMISSION=YES	G1.6 / Commissioning	YES NO	YES	Activation or deactivation of the screen groups. <table border="1" data-bbox="821 1137 1356 1265"> <thead> <tr> <th>OPTION</th> <th>FUNCTION</th> </tr> </thead> <tbody> <tr> <td>COMMISSIONING=Yes</td> <td>It allows all parameter setting.</td> </tr> <tr> <td>COMMISSIONING=No</td> <td>It does not permit parameter setting. It permits parameter to be displayed.</td> </tr> </tbody> </table>	OPTION	FUNCTION	COMMISSIONING=Yes	It allows all parameter setting.	COMMISSIONING=No	It does not permit parameter setting. It permits parameter to be displayed.
OPTION	FUNCTION									
COMMISSIONING=Yes	It allows all parameter setting.									
COMMISSIONING=No	It does not permit parameter setting. It permits parameter to be displayed.									

11.2. Group 2 – G2: NAMEPLATE

Screen	Name / Description	Range	Default Value	Function										
1 I STARTER = 900A	G2.1 / Rated current of the softstarter	7A 17A 30A 45A ... 1600A	In of SS7	Calibrates the soft starter according to nominal current. This is necessary for correct soft starter protection. <u>Adjust:</u> Leave as default setting. To modify nominal current push (*) key for 5 seconds. By that time the letter "I" will change to "I" and the current value can be modified.										
2 I MOTOR=900A	G2.2 / Rated motor current	1 to 1600	*	Set the nominal current of the motor. This is necessary for correct motor protection. <u>Adjust:</u> Set this value according to rated (nameplate) motor current.										
3 V MOTOR=2	G2.3 / Rated motor voltage	1 to 4	2	Adjust nominal motor voltage. <table border="1"> <thead> <tr> <th>OPT.</th> <th>DESCRIPTION</th> </tr> </thead> <tbody> <tr> <td>1</td> <td>220-240V</td> </tr> <tr> <td>2</td> <td>380-440V</td> </tr> <tr> <td>3</td> <td>460-525V</td> </tr> <tr> <td>4</td> <td>660-690V</td> </tr> </tbody> </table> <u>Adjust:</u> Set this parameter according to input voltage at the soft starter input. Make sure this value is also relevant for the rated (Nameplate) motor voltage.	OPT.	DESCRIPTION	1	220-240V	2	380-440V	3	460-525V	4	660-690V
OPT.	DESCRIPTION													
1	220-240V													
2	380-440V													
3	460-525V													
4	660-690V													
4 P MOTOR =450kW	G2.4 / Rated motor power	4 to 999kW	*	Set the nominal motor power rating.										
5 COS PHI M =85%	G2.5 / Motor power factor	40 to 99%	85%	Set the rated (nameplate) motor cos phi to for calculating the instantaneous torque developed by the motor										
6 FREQ= 50Hz	G2.6 / Supply frequency	50Hz 50/60Hz	50Hz	Set the mains frequency. <u>Adjust:</u> Where the mains frequency is 50Hz, leave as default. Where the mains frequency is unknown or different than 50Hz (60Hz) set 50/60Hz. Note: When you 50/60Hz the SS7 starts an algorithm to detect the mains frequency. This algorithm is off when setting 50Hz.										

* This value depends on the rated current of the softstarter.

11.3. Group 3 – G3: PROTECTIONS

Screen	Name / Description	Range	Default Value	Function								
1 PHASE SEQUEN=2	G3.1 / Phase sequence at the input of the softstarter	1 to 3	2	This parameter sets the correct phase sequence at the input, when power on the SS7. It can happen that the soft starter tries to start with a phase sequence at the input different than the one which has been set. In this case the soft starter trips on F2 WRONG PH/SQ.. <table border="1"> <thead> <tr> <th>OPT.</th> <th>DESCRIPTION</th> </tr> </thead> <tbody> <tr> <td>1</td> <td>NO SEQ PROTECT</td> </tr> <tr> <td>2</td> <td>L1 L2 L3 SEQ</td> </tr> <tr> <td>3</td> <td>3 INVERSED SEQ</td> </tr> </tbody> </table> <u>Adjust:</u> Determine input phase sequence; adjust this parameter according to this sequence Note: When operating at SLOW SPEED or DC BRAKE a phase sequence must be selected (L1 L2 L3 or Inverse Sequence). The option 1 NO SEQ PROTECT is not allowed for these modes.	OPT.	DESCRIPTION	1	NO SEQ PROTECT	2	L1 L2 L3 SEQ	3	3 INVERSED SEQ
OPT.	DESCRIPTION											
1	NO SEQ PROTECT											
2	L1 L2 L3 SEQ											
3	3 INVERSED SEQ											
2 OV LOAD=800A	G3.2 / Overload motor current.	(0.6 to 1.5)· In of SS7	In of SS7	This parameter sets the overload motor current protection at nominal conditions. The time for this protection to trip depends on the actual current drawn by the motor and the parameter G3.3 <u>Adjust:</u> Enter the rated (nameplate) motor current value. Note: See figure 11.1.								

Screen	Name / Description	Range	Default Value	Function
3 OV/LOAD T=5	G3.3 / Overload curve	1 to 10	5	<p>The overload curve determines the response time under overload conditions. There is a non-linear relation between the overload parameter (G3.2 OV LOAD) and this parameter, in order to set the time required for tripping on F4 OVERLOAD. If 3 OV/LOAD T =1 is selected then the response time for an overload condition is almost immediate, but if OV/LOAD T=10 then takes the soft starter trips on F4 OVERLOAD after a time delay.</p> <p><u>Adjust:</u> If you need a fast response under overload conditions, please select OV/LOAD T =1. If you need a slow response, then select OV/LOAD T =10. For normal operation leave this value as default (OV/LOAD T =5). The response time for the overload protection can be calculated from the following curve:</p> <p style="text-align: right;">DT0026B</p> <p style="text-align: center;"><i>Figure 11.1 Overload curve.</i></p>
4 OVL FAC=100%	G3.4 Starting Overload Factor	100 to 500%	100%	<p>This parameter adjusts the OVERLOAD CURVE DURING ACCELERATION. This parameter can be used to accelerate high inertia load. In case of pumps, fans (Torque = K x Speed²) leave as default (100%). This parameter is only active during acceleration and not at normal running conditions, where only G3.2 & G3.3 are active.</p> <p><u>Adjust:</u> For low inertia applications like pumps, fans (Torque = K x Speed²) the default value (100%) active. Mills, crushers and centrifuges (high inertia moment) will normally require a start with low starting overload factor (150%) and increase this value until the load accelerates without tripping on F4 OVERLOAD.</p>
5 MOTOR PTC=NO	G3.5 / Enable/Disable PTC motor option	YES NO	NO	<p>The soft starter allows the connection of a standard motor PTC (Terminals T16-T17) to detect overheating of the motor. Every input resistance between 100ohm and 1.7kohms is taken as a correct value (OK) and every value found out of this range is taken as a fault (FAULT). If the MOTOR PTC is set to "Yes" and the input resistance at terminals T16-T17 is out of the valid range, then the soft starter should trip on F8 MOTOR PTC. To protect the motor after tripping due to PTC failure against further thermal overload, the PTC resistance must be less than 260 Ohms to reset the softstarter again. In case of a resistance below 100 Ohms the SS7 can be reset after the PTC has reached again a value of more than 160 Ohms.</p> <p><u>Adjust:</u> Depending on the availability of a valid Motor PTC, select Yes or No.</p>
6 UNLOAD=0.0A	G3.6 Under load current	(0 to 0.9) In of SS7	0.0A	<p>Under load current determines the current level the motor must not operate below.</p> <p><u>Adjust:</u> Usually leave as 50% of the nominal current of the motor.</p> <p><u>Applications:</u> This protection helps to detect mechanical problems such as broken shafts, belts, ... when this occurs, the motor will run under no load conditions.</p> <p>When working with pumps, this protection helps to detect no load pump operation, due to a lack of water or pump input pipe water position.</p>
7 UNLOAD T=OFF	G3.7 / Under load delay	0 to 99s, OFF	OFF	<p>This parameter sets the maximum allowable operation time under load conditions before tripping.</p> <p><u>Adjust:</u> Depends on the application, but should be set to trip as soon as a condition occurs.</p> <p><u>Applications:</u> Pumps, fans.</p>

Screen	Name / Description	Range	Default Value	Function						
8 SHRPIN=OFF	G3.8 / Shearpin current	(0.6 to 1.2)·In of SS7, OFF	OFF	The soft starter will stop immediately when the current drawn by the motor reaches this value during normal operation. This parameter is off during acceleration or deceleration. The stop should be done in a controlled way. <u>Adjust:</u> Set current value for the SS7 to stop. <u>Application:</u> Oversized electrical motors used for starting, but working under nominal conditions at running, may only reach the Shearpin current because of mechanical problems locked rotors, etc.						
9 ASYM I ENB=Y	G3.9 / Asymmetrical current	Y N	Y	Enable/Disable the asymmetric current protection at the soft starter <table border="1"> <thead> <tr> <th>OPTION</th> <th>FUNCTION</th> </tr> </thead> <tbody> <tr> <td>Y=YES</td> <td>When enabled, the soft starter will trip on F3 ASYM CURR if there is a current imbalance greater than 40%.</td> </tr> <tr> <td>N=NO</td> <td>Protection disabled.</td> </tr> </tbody> </table>	OPTION	FUNCTION	Y=YES	When enabled, the soft starter will trip on F3 ASYM CURR if there is a current imbalance greater than 40%.	N=NO	Protection disabled.
OPTION	FUNCTION									
Y=YES	When enabled, the soft starter will trip on F3 ASYM CURR if there is a current imbalance greater than 40%.									
N=NO	Protection disabled.									
10 UNDER V=320V	G3.10 / Under voltage	162 to 208V @220V 280 to 360V @400V 350 to 450V @500V 508 to 653V @690V	320V	To protect the motor or other equipment from low mains voltage. Low voltage will usually increase the motor current. <u>Adjust:</u> Set the minimum tolerable level in conjunction with 11 Under voltage Delay.						
UNDERVOLTAGE DELAY	G3.11 Under voltage delay	0 to 10s, OFF	5s	This parameter sets the maximum operation time for under voltage conditions before tripping. <u>Adjust:</u> Set to maximum under voltage operation time allowed						
12 OVERVOLT=440V	G3.12 / Over voltage	231 to 266V @230V 400 to 460V @400V 500 to 575V @500V 726 to 835V @690V	440V	To protect the motor from high input voltage. <u>Adjust:</u> Set the maximum level tolerable in conjunction with the 13 Over voltage timeout.						
13 O/V DELAY=5s	G3.13 / Over voltage timeout	0 to 10s, OFF	5s	This parameter sets the maximum operation time during over voltage conditions before tripping. <u>Adjust:</u> Set to maximum over voltage operation time allowed.						
14 START LIMIT=3	G3.14 / Maximum number of starts	1 to 10	3	Establish the maximum number of starts allowed before tripping on F12 EXCESIV STR. <u>Adjust:</u> Set maximum number of starts allowed for the specified time at 15: START INTERVAL.						
15 STR/INT=15Min	G3.15 / Start interval	0 to 60Min, OFF	15Min	Establish the time allowed between the first and the last start in G3.14: START LIMIT before tripping on F12 EXCESIV STR. <u>Adjust:</u> Set the time limit for the maximum number of starts to occur. <u>Applications:</u> Mills, crushers, and applications where an excessive number of starts could damage the motor due to very high current during acceleration.						

11.4. Group 4 – G4: ACCELERATION

Screen	Name / Description	Range	Default Value	Function
1 STR DELAY=0s	G4.1 / Delay of the start	0 to 600s	0s	Sets the time the SS7 will wait after a start command has been provided and acceleration will start. <u>Adjust:</u> This value needs to be set in accordance with the application.
2 PULS TORQ =50%	G4.2 Torque Pulse	50 to 100%	50%	Choose the torque pulse level applied to the motor for the time specified at G4.3. <u>Adjust:</u> This value needs to be set in conjunction with G4.3 to initiate a first move of the motor.
3 PULS TQ T=OFF	G4.3 / Torque Pulse Time	OFF, 0.1 to 0.9s	OFF	Sets the time for the G4.2 PULS TORQ to be applied.

Screen	Name / Description	Range	Default Value	Function
4 INIT TORQ=35%	G4.4 / Initial Torque	30 to 99%	35%	Establish the initial torque to be applied to the motor at the beginning of the ramp up. <u>Adjust:</u> It is recommended to begin with a low initial torque value, normally default. Observe motor rotation immediately after start command. If the motor doesn't spin, machine torque requirement may be higher, and it may be necessary to increase this until the motor starts to turn normal after a start command has been applied. If a very high current is noticed at the very beginning of starting process, this could be due to an initial torque setting that is too high - this must be decreased until a proper value is achieved. <u>Applications:</u> For submerged pumps, generally a torque between 40% and 45% is required. For applications such as mills or crushers, the required torque is normally between 40% and 50%. Note: These values are typical adjustments. Each application requires individual settings to achieve the best performance.
5 INIT TQ T=1s	G4.5 / Initial torque time	0 to 10s	1s	Set the time for 3 INITIAL TORQUE to be applied to the motor. <u>Adjust:</u> When working with high inertia loads, increase this value in conjunction with parameter G4.4 INITIAL TORQUE, until the motor begins to turn. All other applications should leave this value as default. <u>Applications:</u> In pumps a usual value is 0, and in heavy load machines it can vary between 1 and 3 seconds.
<p style="text-align: right;">G4.1 Delay of the start G4.2 Torque pulse G4.3 Torque pulse time G4.4 Initial torque G4.5 Initial torque time G4.6 Acceleration time G5.2 Deceleration time</p> <p style="text-align: right;">DT0018D</p>				
<p>Figure 11.2 Pulse torque</p>				
6 ACEL TIME=6s	G4.6 / Acceleration Time	0 to 180s	6s	Adjusts the motor acceleration time from standstill to nominal speed, provided that no current limit occurs as that will cause a longer acceleration time. <u>Adjust:</u> Depending on the application, the time set will vary in order to make sure no current limit takes place during acceleration. If this occurs, the acceleration time or acceleration current limit settings will need to be increased <u>Applications:</u> In submerged pumps, the usual acceleration time is between 4 and 8 seconds. With very high inertial loads, that can vary between 20 and 60 seconds. Note: These values are typical adjustments. Each application requires individual settings to achieve the best performance.
7 I LIMIT=1400A	G4.7 / Current limit	(1.5 to 5)·In of SS7	(3.5)·In	Maximum current a motor can draw during the acceleration/deceleration. <u>Adjust:</u> Set the maximum current a motor can draw during the acceleration/deceleration of the motor. Typically set to 2.5 to 3x nominal current of the motor. Values below 2 times of the motor rated current should be avoided. Under these conditions the resulting motor torque is normally insufficient to generate a successful start at full load; also the soft starter could trip on F4 Overload.

11.5. Group 5 – G5: DECELERATION

Screen	Name / Description	Range	Default Value	Function						
1 FREWEL STP=Y	G5.1 / Freewheel stop	Y N	Y	<p>Set the required stop mode. The stop could be controlled through a ramp down voltage or uncontrolled where the time to stop depends on the inertia of the load</p> <table border="1"> <thead> <tr> <th>OPTION</th> <th>FUNCTION</th> </tr> </thead> <tbody> <tr> <td>Y=YES</td> <td>Freewheel stop enabled.</td> </tr> <tr> <td>N=NO</td> <td>Freewheel stop disabled.</td> </tr> </tbody> </table> <p>Adjust: If a controlled stop is required select 1 FREWELSTOP=No, and 1 FREWELSTOP=Yes for a spinning stop.</p>	OPTION	FUNCTION	Y=YES	Freewheel stop enabled.	N=NO	Freewheel stop disabled.
OPTION	FUNCTION									
Y=YES	Freewheel stop enabled.									
N=NO	Freewheel stop disabled.									
2 DECL TIME=12s	G5.2 / Deceleration Time	1 to 180s	12s	<p>Establish the required time for a controlled stop.</p> <p>Adjust: Begin with a short time (10 or 15 seconds) and increase it until desired stop is achieved. If no satisfactory results are obtained set hammer algorithm in G5.3.</p>						
<div style="text-align: center;"> <p>Figure 11.3 Deceleration curve</p> <p>DT0019D</p> </div>										
3 DEC MD SEL=1	G5.3 / Motor Deceleration Algorithm	1 to 2	1	<p>In applications where it is necessary to avoid water hammer effect, select this algorithm. In other applications, the normal deceleration ramp is sufficient.</p> <table border="1"> <thead> <tr> <th>OPT.</th> <th>DESCRIPTION</th> </tr> </thead> <tbody> <tr> <td>1</td> <td>NORMAL CURVE.</td> </tr> <tr> <td>2</td> <td>HAMMER PREVENT.</td> </tr> </tbody> </table> <p>Adjust: In applications with water hammer problems during deceleration, select the hammer algorithm. In other applications set normal deceleration algorithm.</p> <p>When selecting the hammer algorithm for the deceleration, 2 parameters must be set to properly adjust the stop.</p> <p>For correct adjustment of the deceleration time in applications with hammer problems it may be necessary to perform an interactive process by trial and error until the application is correctly commissioned.</p>	OPT.	DESCRIPTION	1	NORMAL CURVE.	2	HAMMER PREVENT.
OPT.	DESCRIPTION									
1	NORMAL CURVE.									
2	HAMMER PREVENT.									
4 HAMR FACT=75%	G5.4 / Hammer factor	1 to 99%	75%	<p>Set the percentage of time for the hammer algorithm is to be active during deceleration</p>						
5 MINI TORQ=1%	G5.5 / Minimum torque	1 to 99%	1%	<p>The minimum torque to be applied during deceleration (for Hammer Algorithm).</p>						

11.6. Group 6 – G6: INPUTS

Screen	Name / Description	Range	Default Value	Function																																				
1 OPER MODE=1	G6.1 / Control mode source	0 to 5	1	Set the control mode of the soft starter <table border="1"> <thead> <tr> <th>OPT.</th> <th>DESCRIPTION</th> <th>FUNCTION</th> </tr> </thead> <tbody> <tr> <td>0</td> <td>Disable</td> <td>No control source enabled. There is no way to Start/Stop-Reset the SS7.</td> </tr> <tr> <td>1</td> <td>Local</td> <td>Start/Stop-Reset enabled by keypad.</td> </tr> <tr> <td>2</td> <td>Remote</td> <td>Start/Stop-Reset enabled by digital inputs.</td> </tr> <tr> <td>3</td> <td>Serial Comms</td> <td>Start/Stop-Reset enabled by serial comms.</td> </tr> <tr> <td>4</td> <td>Local Jog V/S</td> <td>Jog Slow Speed controlled by keypad.</td> </tr> <tr> <td>5</td> <td>Pump ctrl-1</td> <td>Pump control 1 enable.</td> </tr> </tbody> </table>	OPT.	DESCRIPTION	FUNCTION	0	Disable	No control source enabled. There is no way to Start/Stop-Reset the SS7.	1	Local	Start/Stop-Reset enabled by keypad.	2	Remote	Start/Stop-Reset enabled by digital inputs.	3	Serial Comms	Start/Stop-Reset enabled by serial comms.	4	Local Jog V/S	Jog Slow Speed controlled by keypad.	5	Pump ctrl-1	Pump control 1 enable.															
OPT.	DESCRIPTION	FUNCTION																																						
0	Disable	No control source enabled. There is no way to Start/Stop-Reset the SS7.																																						
1	Local	Start/Stop-Reset enabled by keypad.																																						
2	Remote	Start/Stop-Reset enabled by digital inputs.																																						
3	Serial Comms	Start/Stop-Reset enabled by serial comms.																																						
4	Local Jog V/S	Jog Slow Speed controlled by keypad.																																						
5	Pump ctrl-1	Pump control 1 enable.																																						
2 LOCAL RESET=Y	G6.2 / Local reset control	Y N	Y	Enable local reset via keypad.																																				
3 DINPUT1 SEL=4	G6.3 / Multifunction 1 input	0 to 10	4	Select the task of the digital input once it is active (X). <table border="1"> <thead> <tr> <th>OPT.</th> <th>MODE</th> <th>FUNCTION</th> </tr> </thead> <tbody> <tr> <td>0</td> <td>Not active</td> <td>The input left without effect.</td> </tr> <tr> <td>1</td> <td>Start</td> <td>Start command given through pushbutton.</td> </tr> <tr> <td>2</td> <td>Stop</td> <td>Stop command given through pushbutton.</td> </tr> <tr> <td>3</td> <td>Stop-Reset</td> <td>Stop/Reset command given through pushbutton.</td> </tr> <tr> <td>4</td> <td>Start-Stop</td> <td>Start command when contact is closed and stop command when contact is opened.</td> </tr> <tr> <td>5</td> <td>Reset</td> <td>The reset is done when the contact is closed.</td> </tr> <tr> <td>6</td> <td>Slow Speed +</td> <td>Slow speed in + direction.</td> </tr> <tr> <td>7</td> <td>Slow Speed -</td> <td>Slow speed in – direction.</td> </tr> <tr> <td>8</td> <td>DC Brake</td> <td>Contact will be closed to apply CC braking after deceleration.</td> </tr> <tr> <td>9</td> <td>Dual setting</td> <td>Selection of the Second Setting at G8.</td> </tr> <tr> <td>10</td> <td>External trip</td> <td>Fault will be generated when the contact is opened.</td> </tr> </tbody> </table>	OPT.	MODE	FUNCTION	0	Not active	The input left without effect.	1	Start	Start command given through pushbutton.	2	Stop	Stop command given through pushbutton.	3	Stop-Reset	Stop/Reset command given through pushbutton.	4	Start-Stop	Start command when contact is closed and stop command when contact is opened.	5	Reset	The reset is done when the contact is closed.	6	Slow Speed +	Slow speed in + direction.	7	Slow Speed -	Slow speed in – direction.	8	DC Brake	Contact will be closed to apply CC braking after deceleration.	9	Dual setting	Selection of the Second Setting at G8.	10	External trip	Fault will be generated when the contact is opened.
OPT.	MODE	FUNCTION																																						
0	Not active	The input left without effect.																																						
1	Start	Start command given through pushbutton.																																						
2	Stop	Stop command given through pushbutton.																																						
3	Stop-Reset	Stop/Reset command given through pushbutton.																																						
4	Start-Stop	Start command when contact is closed and stop command when contact is opened.																																						
5	Reset	The reset is done when the contact is closed.																																						
6	Slow Speed +	Slow speed in + direction.																																						
7	Slow Speed -	Slow speed in – direction.																																						
8	DC Brake	Contact will be closed to apply CC braking after deceleration.																																						
9	Dual setting	Selection of the Second Setting at G8.																																						
10	External trip	Fault will be generated when the contact is opened.																																						
4 DINPUT2 SEL=0	G6.4 / Multifunction 2 input	0 to 10	0																																					
5 DINPUT3 SEL=0	G6.5 / Multifunction 3 input	0 to 10	0																																					
6 DINPUT4 SEL=0	G6.6 / Multifunction 4 input	0 to 10	0																																					
7 DINPUT5 SEL=0	G6.7 / Multifunction 5 input	0 to 10	0																																					

Screen	Name / Description	Range	Default Value	Function								
8 ANI1 FORMAT =1	G6.8 / Analogue Input 1 Format	0 to 2	1	It configures the AI1 as voltage or current signal. <table border="1"> <thead> <tr> <th>OPT.</th> <th>DESCRIPTION</th> </tr> </thead> <tbody> <tr> <td>0</td> <td>0-20mA</td> </tr> <tr> <td>1</td> <td>4-20mA</td> </tr> <tr> <td>2</td> <td>0-10V</td> </tr> </tbody> </table>	OPT.	DESCRIPTION	0	0-20mA	1	4-20mA	2	0-10V
OPT.	DESCRIPTION											
0	0-20mA											
1	4-20mA											
2	0-10V											
<div style="display: flex; justify-content: space-around;"> <div style="text-align: center;"> <p>Format 0-20mA Range 0-10bar Sensor Output 0-20mA</p> </div> <div style="text-align: center;"> <p>Format 4-20mA Range 0-10bar Sensor Output 4-20mA</p> </div> </div> <p style="text-align: right;">DT0028C</p> <p style="text-align: center;"><i>Figure 11.4 Analogue input 1 scaled as 0-20mA / 4-20mA</i></p>												
9 AI1 RANGE 0_10	G6.9 / Range of the Analogue Input 1 in absolute units	0_0 to 0_999	0_10	<u>Adjust</u> : Set according to the range of the connected transducer.								
10 AI1 UNITS=OFF	G6.10 / Analogue Input 1 units	OFF, Bar °C Mtr	OFF	When OFF, is displayed in %.								
11 ANI2 FORMAT =1	G6.11 Analogue Input 2 Format	0 to 2	1	It configures the AI2 as voltage or current signal. <table border="1"> <thead> <tr> <th>OPT.</th> <th>DESCRIPTION</th> </tr> </thead> <tbody> <tr> <td>0</td> <td>0-20mA</td> </tr> <tr> <td>1</td> <td>4-20mA</td> </tr> <tr> <td>2</td> <td>0-10V</td> </tr> </tbody> </table>	OPT.	DESCRIPTION	0	0-20mA	1	4-20mA	2	0-10V
OPT.	DESCRIPTION											
0	0-20mA											
1	4-20mA											
2	0-10V											
12 AI2 RANGE 0_10	G6.12 / Range of the Analogue Input 2 in absolute units	0_0 to 0_999	0_10	<u>Adjust</u> : Set according to the range of the connected transducer.								
13 AI2 UNITS=OFF	G6.13 / Analogue Input 2 units	OFF, Bar °C Mtr	OFF	When OFF, is displayed in %.								

11.7. Group 7 – G7: OUTPUTS

Screen	Name / Description	Range	Default Value	Function		
1 REL1 SEL ON=14	G7.1 / Relay 1 control source selection	0 to 21	14	Provides the ability to link each relay to one of the outputs shown below.		
				OPT.	DESCRIPTION	FUNCTION
				0	Not active	Relay is disabled, not used.
				1	Active	Relay is enabled.
				2	Warning overload	The motor current exceeds the value adjusted in parameter G3.2 (OVERLOAD CURRENT).
				3	Warning under load	The motor current is below the value adjusted in parameter G3.6 (UNDERLOAD CURRENT).
				4	Warning over voltage	The mains voltage is equal or higher than G3.12 (OVERVOLTAGE).
				5	Warning low voltage	The mains voltage is less or equal than G3.10 (UNDERVOLTAGE).
				6	Comparator 1	Relay enables when the value of the parameter set in screen G9.1 is above screen G9.2 value after time set in screen G9.4. Relay disables when the value of the parameter set in screen G9.1 is below screen G9.3 value after time set in screen G9.5.
				7	Comparator 2	Relay enables when the value of the parameter set in screen G9.6 is above screen G9.7 value after time set in screen G9.9. Relay disables when the value of the parameter set in screen G9.6 is below screen G9.8 value after time set in screen G9.10.
8	Comparator 3	Relay enables when the value of the parameter set in screen G9.11 is above screen G9.12 value after time set in screen G9.14. Relay disables when the value of the parameter set in screen G9.11 is below screen G9.13 value after time set in screen G9.15.				
				Note: See following page.		

Screen	Name / Description	Range	Default Value	Function																																																				
2 REL2 SEL ON=15	G7.2 / Relay 2 control source selection	0 to 21	15	<p>Note: Coming from previous page.</p> <table border="1"> <thead> <tr> <th>OPT.</th> <th>DESCRIPTION</th> <th>FUNCTION</th> </tr> </thead> <tbody> <tr> <td>9</td> <td>General Fault</td> <td>Relay will be active a fault occurs.</td> </tr> <tr> <td>10</td> <td>No fault</td> <td>Will be active if no faults are present (failsafe).</td> </tr> <tr> <td>11</td> <td>Thyristor fault</td> <td>One or more thyristors are fault.</td> </tr> <tr> <td>12</td> <td>Autoreset Fault</td> <td>Relay enables when screen G15.2 Attempt number setting is passed over.</td> </tr> <tr> <td>13</td> <td>Ready</td> <td>The soft starter is ready to run the motor.</td> </tr> <tr> <td>14</td> <td>Run</td> <td>ON at the beginning of the ramp up / OFF at the end of the ramp down.</td> </tr> <tr> <td>15</td> <td>Bypass/React</td> <td>ON at the end of the ramp up / OFF at the beginning of the ramp down.</td> </tr> <tr> <td>16</td> <td>Delay</td> <td>ON at the end of the ramp up / OFF at the end of the ramp down.</td> </tr> <tr> <td rowspan="6">3 REL3 SEL ON=9</td> <td rowspan="6">G7.3 / Relay 3 control source selection</td> <td rowspan="6">0 to 21</td> <td rowspan="6">9</td> <td>17</td> <td>High pressure</td> <td>The SS7 is running and the pressure switch opens for longer than the time entered in screen G16.4</td> </tr> <tr> <td>18</td> <td>Low pressure</td> <td>The SS7 is running and the pressure switch opens for longer than the time entered in screen G16.5.</td> </tr> <tr> <td>19</td> <td>No flow</td> <td>The flow switch is ignored for the time set in screen G16.6 on receipt of a valid start signal. After this time the SS7 will trip if no flow is indicated for longer than the time set in screen G16.7.</td> </tr> <tr> <td>20</td> <td>Low water</td> <td>The well probe controller (or other level controller) detects a lack of water.</td> </tr> <tr> <td>21</td> <td>Pump fault</td> <td>A fault from F24 to F27 and F5 has occurred. Pump related faults.</td> </tr> <tr> <td colspan="4"></td> <td colspan="2"> <p>Note: Relay 3 can be configured the same as relay 1 and 2, with the 21 possible adjustments except if the EXTERNAL BRAKE option has been selected in screen G13.4. In that case, relay 3 will remain internally adjusted, for control of the EXTERNAL DC BRAKE and cannot be configured.</p> </td> </tr> </tbody> </table>	OPT.	DESCRIPTION	FUNCTION	9	General Fault	Relay will be active a fault occurs.	10	No fault	Will be active if no faults are present (failsafe).	11	Thyristor fault	One or more thyristors are fault.	12	Autoreset Fault	Relay enables when screen G15.2 Attempt number setting is passed over.	13	Ready	The soft starter is ready to run the motor.	14	Run	ON at the beginning of the ramp up / OFF at the end of the ramp down.	15	Bypass/React	ON at the end of the ramp up / OFF at the beginning of the ramp down.	16	Delay	ON at the end of the ramp up / OFF at the end of the ramp down.	3 REL3 SEL ON=9	G7.3 / Relay 3 control source selection	0 to 21	9	17	High pressure	The SS7 is running and the pressure switch opens for longer than the time entered in screen G16.4	18	Low pressure	The SS7 is running and the pressure switch opens for longer than the time entered in screen G16.5.	19	No flow	The flow switch is ignored for the time set in screen G16.6 on receipt of a valid start signal. After this time the SS7 will trip if no flow is indicated for longer than the time set in screen G16.7.	20	Low water	The well probe controller (or other level controller) detects a lack of water.	21	Pump fault	A fault from F24 to F27 and F5 has occurred. Pump related faults.					<p>Note: Relay 3 can be configured the same as relay 1 and 2, with the 21 possible adjustments except if the EXTERNAL BRAKE option has been selected in screen G13.4. In that case, relay 3 will remain internally adjusted, for control of the EXTERNAL DC BRAKE and cannot be configured.</p>	
					OPT.	DESCRIPTION	FUNCTION																																																	
9	General Fault	Relay will be active a fault occurs.																																																						
10	No fault	Will be active if no faults are present (failsafe).																																																						
11	Thyristor fault	One or more thyristors are fault.																																																						
12	Autoreset Fault	Relay enables when screen G15.2 Attempt number setting is passed over.																																																						
13	Ready	The soft starter is ready to run the motor.																																																						
14	Run	ON at the beginning of the ramp up / OFF at the end of the ramp down.																																																						
15	Bypass/React	ON at the end of the ramp up / OFF at the beginning of the ramp down.																																																						
16	Delay	ON at the end of the ramp up / OFF at the end of the ramp down.																																																						
3 REL3 SEL ON=9	G7.3 / Relay 3 control source selection	0 to 21	9	17	High pressure	The SS7 is running and the pressure switch opens for longer than the time entered in screen G16.4																																																		
				18	Low pressure	The SS7 is running and the pressure switch opens for longer than the time entered in screen G16.5.																																																		
				19	No flow	The flow switch is ignored for the time set in screen G16.6 on receipt of a valid start signal. After this time the SS7 will trip if no flow is indicated for longer than the time set in screen G16.7.																																																		
				20	Low water	The well probe controller (or other level controller) detects a lack of water.																																																		
				21	Pump fault	A fault from F24 to F27 and F5 has occurred. Pump related faults.																																																		
								<p>Note: Relay 3 can be configured the same as relay 1 and 2, with the 21 possible adjustments except if the EXTERNAL BRAKE option has been selected in screen G13.4. In that case, relay 3 will remain internally adjusted, for control of the EXTERNAL DC BRAKE and cannot be configured.</p>																																																
				<p style="text-align: right;">DT0033B</p>																																																				

Figure 11.5 Relay's switch on / off mode 14, 15 and 16.

Screen	Name / Description	Range	Default Value	Function																		
4 ANALOG1 SEL=0	G7.4 / Analogue output source selection	0 to 7	0	Provides the ability to select the driving source of the Analogue output, from the following list. <table border="1" style="margin-left: 20px;"> <thead> <tr> <th>OPT.</th> <th>DESCRIPTION</th> </tr> </thead> <tbody> <tr><td>0</td><td>UNUSED</td></tr> <tr><td>1</td><td>MOTOR CURRENT</td></tr> <tr><td>2</td><td>MOTOR POWER</td></tr> <tr><td>3</td><td>MOTOR TORQUE</td></tr> <tr><td>4</td><td>COSINUS PHI</td></tr> <tr><td>5</td><td>INPUT VOLTAGE</td></tr> <tr><td>6</td><td>ANALOG I 1 ECHO</td></tr> <tr><td>7</td><td>ANALOG I 2 ECHO</td></tr> </tbody> </table>	OPT.	DESCRIPTION	0	UNUSED	1	MOTOR CURRENT	2	MOTOR POWER	3	MOTOR TORQUE	4	COSINUS PHI	5	INPUT VOLTAGE	6	ANALOG I 1 ECHO	7	ANALOG I 2 ECHO
OPT.	DESCRIPTION																					
0	UNUSED																					
1	MOTOR CURRENT																					
2	MOTOR POWER																					
3	MOTOR TORQUE																					
4	COSINUS PHI																					
5	INPUT VOLTAGE																					
6	ANALOG I 1 ECHO																					
7	ANALOG I 2 ECHO																					
5 AO1 FORMAT=0	G7.5 / Analogue output format	0 to 1	0	Select the electrical format of the Analogue output. <table border="1" style="margin-left: 20px;"> <thead> <tr> <th>OPT.</th> <th>DESCRIPTION</th> </tr> </thead> <tbody> <tr><td>0</td><td>0-20mA</td></tr> <tr><td>1</td><td>4-20mA</td></tr> </tbody> </table> <p>Note: To obtain an analogue output of 0-10V, you should configure the analogue output format as 0-20mA and connect a resistor of 500 Ω, ¼ W and 1% between terminals 22 and 23.</p>	OPT.	DESCRIPTION	0	0-20mA	1	4-20mA												
OPT.	DESCRIPTION																					
0	0-20mA																					
1	4-20mA																					
<div style="display: flex; justify-content: space-around;"> <div style="text-align: center;"> <p>Format 0-20mA Lower limit 0% Higher limit 100%/ 200%</p> </div> <div style="text-align: center;"> <p>Format 4-20mA Lower limit 0% Higher limit 100%/ 200%</p> </div> </div> <p style="text-align: right;">DT0034B</p> <p style="text-align: center;"><i>Figure 11.6 Analogue output 0-20mA and 4-20mA.</i></p>																						
6 AO1 LOW=0%	G7.6 Analogue Output low set point	0 to 500%	0%	It scales de Analogue Output in order to get a better reading.																		
7 AO1 HIGH=100%	G7.7 / Analogue Output high set point	0 to 500%	100%																			

11.8. Group 8 – G8: DUAL SETTING

Screen	Name / Description	Range	Default Value	Function						
1 DUALSETTING=N	G8.1 / Dual Setting.	Y N	N	Enable/Disable a second adjustment for G4 Acceleration, G5 Deceleration and for the overload curve (G3.3 Overload Curve). <table border="1" style="margin-left: 20px;"> <thead> <tr> <th>OPTION</th> <th>FUNCTION</th> </tr> </thead> <tbody> <tr><td>Y=YES</td><td>Dual setting enabled.</td></tr> <tr><td>N=NO</td><td>Dual setting disabled.</td></tr> </tbody> </table> <p><u>Adjust:</u> When a second parameter is required set select Dual Setting to Yes. This second adjustment is activated by one of digital inputs. <u>Applications:</u> Mills, crushers and any application that at a certain operation stage requires a harder/softer parameter set.</p>	OPTION	FUNCTION	Y=YES	Dual setting enabled.	N=NO	Dual setting disabled.
OPTION	FUNCTION									
Y=YES	Dual setting enabled.									
N=NO	Dual setting disabled.									
2 PLS TORQ2=50%	G8.2 Dual setting Torque Pulse	50 to 100%	50%	Choose the torque pulse level applied to the motor for the time specified at G8.3 <u>Adjust:</u> Set this value in conjunction with G8.3 to initiate a first acceleration of the motor.						
3 PLS TQ T2=OFF	G8.3 / Dual setting Pulse Time.	OFF, 0.1 to 0.9s	OFF	Sets the time for the torque pulse (G8.2) to be applied.						

Screen	Name / Description	Range	Default Value	Function								
4 INIT TRQ2 =30%	G8.4 / Dual setting Initial Torque	30 to 99%	30%	Establish the initial torque to be applied to the motor at the beginning of the ramp up. <u>Adjust:</u> Refer to parameter G4.4 for further information.								
5 T PAR INI2=1s	G8.5 / Dual setting Initial Torque Time	0 to 10s	1s	Set the time for the initial torque (G8.4) to be applied to the motor. <u>Adjust:</u> Refer to parameter G4.5 for further information.								
6 ACC TIME2=12s	G8.6 / Dual setting Acceleration time	0 to 180s	12s	Adjust the motor acceleration time from standstill to nominal speed, provided that no current limit occurs as that will cause a longer acceleration time. <u>Adjust:</u> The time setting depends on the application. Refer to parameter G4.6 for further information.								
7 I LIMIT2 =2800A	G8.7 / Dual Setting current limit	(1.5 to 5)·In of SS7	3·In	Maximum current a motor can draw during the acceleration/deceleration. <u>Adjust:</u> Set to determine the maximum allowed current consumption during the acceleration/deceleration. Refer to parameter G4.7 for further information.								
8 FREWEL STP2=N	G8.8 / Dual setting spin stop	Y N	N	Set the required stop mode. The stop could be controlled through a ramp down voltage or uncontrolled where the time to stop depends on the inertia of the load (freewheel stop). <u>Adjust:</u> If a controlled stop is required, set "N" for a spinning stop, set Y. Refer to parameter G5.1 for further information.								
9 DEC TIME2=12s	G8.9 / Dual setting deceleration time	0 to 180s	12s	Establish the required time for a controlled stop. <u>Adjust:</u> Begin with a short time and increase it until desired stop is achieved. Refer to parameter G5.2 for further information.								
10 DEC MD SEL2= 11	G8.10 / Dual setting deceleration mode select	1 to 2	1	In applications where it's desired to avoid water hammer effect, select this algorithm. In other applications, the normal deceleration ramp is sufficient. <table border="1"> <thead> <tr> <th>OPT.</th> <th>DESCRIPTION</th> </tr> </thead> <tbody> <tr> <td>1</td> <td>NORMAL</td> </tr> <tr> <td>2</td> <td>HAMMER PREVENT</td> </tr> </tbody> </table> <u>Adjust:</u> In applications with water hammer problems during deceleration, select the hammer algorithm. In other applications set normal deceleration algorithm. When selecting the hammer algorithm for the deceleration, 2 parameters must be set to properly adjust the stop. Percentage of time the hammer algorithm is active during the deceleration time. Minimum torque the motor must deliver during the stop. To correctly adjust the deceleration of such an application with hammer problems you may need to perform an interactive process by trial and error until the application is correctly commissioned.	OPT.	DESCRIPTION	1	NORMAL	2	HAMMER PREVENT		
OPT.	DESCRIPTION											
1	NORMAL											
2	HAMMER PREVENT											
11 HAMR FAC2=75%	G8.11 / Dual setting hammer factor	1 to 99%	75%	Set the percentage of time for the hammer algorithm is to be active during deceleration. <u>Adjust:</u> It is set in % of the deceleration time of the motor (G8.9).								
12 MINI TRQ2=1%	G8.12 / Dual setting minimum torque 2	1 to 99% of G8.11	1%	Set the minimum torque to be applied during deceleration (for Hammer Algorithm).								
13 PHASE SEQ2=2	G8.13 / Dual setting in phase sequence at the input of the soft starter	1 to 3	2	This parameter sets the correct phase sequence at the input, when starting the motor. It can happen that the soft starter tries to start with a phase sequence at the input different than the one we have set. In this case the soft starter trips on F2 WRONG PH/SQ. <table border="1"> <thead> <tr> <th>OPT.</th> <th>DESCRIPTION</th> </tr> </thead> <tbody> <tr> <td>1</td> <td>NO SEQ PROTECT</td> </tr> <tr> <td>2</td> <td>L1 L2 L3 SEQ</td> </tr> <tr> <td>3</td> <td>2 L1 L2 L3 seq</td> </tr> </tbody> </table> <u>Adjust:</u> Determine your input phase sequence; adjust this parameter according to this sequence. Note: When operating at SLOW SPEED or DC BRAKE you must always select a phase sequence (L1 L2 L3 or Inverse Sequence). The option 1 NO SEQ PROTECT is not allowed for these modes.	OPT.	DESCRIPTION	1	NO SEQ PROTECT	2	L1 L2 L3 SEQ	3	2 L1 L2 L3 seq
OPT.	DESCRIPTION											
1	NO SEQ PROTECT											
2	L1 L2 L3 SEQ											
3	2 L1 L2 L3 seq											
14 OV LOAD2=1200A	G8.14 / Dual setting of overload motor current	(0.6 to 1.5)·In of SS7	In of SS7	This parameter sets the overload motor current protection at nominal conditions. The time for this protection to trip depends on the actual current drawn by the motor and the parameter G3.3. <u>Adjust:</u> Enter the rated (nameplate) motor current value.								
15 OV/LOAD T2=5	G8.15 / Dual setting of overload curve	1 to 10	5	This parameter sets the overload motor current protection at nominal conditions. The time for this protection to trip depends on the actual current drawn by the motor and the parameter G3.3. <u>Adjust:</u> If you need a fast response under overload conditions, please select O OV/LOAD T =1. If you need a slow response, then select OV/LOAD T =10. For normal operation leave this value as default (OV/LOAD T =5).								

Screen	Name / Description	Range	Default Value	Function										
16 OVL FAC2=100%	G8.16 Dual setting starting Overload Factor	100 to 500%	100%	This parameter adjusts the OVERLOAD CURVE DURING ACCELERATION. Use this parameter when trying to accelerate high inertia load. In case of pumps, fans (Torque = K x Speed ²) leave as default (100%). This parameter is only active during acceleration and not in normal running conditions, where only G3.2 & G3.3 are active. For low inertia pumps, fans (Torque = K x Speed ²) leave as default value (100%). For mills, crushes and centrifuges (high inertia moment) start with low starting overload factor (150%) and increase this value till we can accelerate this load without tripping on F4 OVERLOAD.										
17 MTR PTC2=N	G8.17 / Dual setting Enable/Disable PTC motor option	Y N	NO	The soft starter allows for the connection of a standard motor PTC (Terminals T16-T17) to detect overheating of the motor. Every input resistance between 150ohm and 2.7kohms is taken as a correct value (ok) and every value found out of this range is taken as a fault (fault). If you select MOTOR PTC =Yes and the input resistance at terminals T16-T17 is out of the valid range, then the soft starter should trip on F8 MOTOR PTC. To protect the motor after tripping due to PTC alarm against further thermal overload, the PTC resistance. <u>Adjust:</u> Depending on availability of a valid Motor PTC, select Yes or No.										
18 UNLOAD2=0.0A	G8.18 / Dual setting of under load current	(0 to 0.9)·In of SS7	0.0A	Under load current determines the current level the motor must not operate below. <u>Adjust:</u> Usually leave as 50% of the nominal current of the motor. <u>Applications:</u> This protection helps to detect mechanical problems such as broken shafts, belts, ... when this occurs, the motor will running under no load conditions. When working with pumps, this protection help to detect no load pump operation, due to a lack of water or pump input pipe water position.										
19 UNLOAD T2=OFF	G8.19 / Dual setting of under load delay	0 to 99s, OFF	OFF	This parameter sets the maximum allowable operation time under load conditions before tripping. <u>Adjust:</u> Depends on the application, but should be set to trip as soon as a condition occurs. <u>Applications:</u> Pumps, fans.										
20 SHRPIN2=OFF	G8.20 Dual setting Shearpin current	(0.6 to 1.2)·In of SS7, OFF	OFF	The soft starter should stop immediately when the current drawn by the motor reaches this value during nominal conditions. This parameter is off during acceleration or deceleration. The stop should be done in a controlled way. <u>Adjust:</u> Set current value for the SS7 to stop. <u>Application:</u> Oversized electrical motors used for starting, but working under nominal conditions at running, it may only reach the Shearpin current due to mechanical problems like locked rotors, etc.										
21 ASYM I ENB2=N	G8.21 / Dual setting of an asymmetrical current	Y N	N	Enable/Disable the asymmetric current protection at the soft starter. When enabled, the soft starter will trip on F3 ASYMMETRIC CURRENT if there is a current imbalance greater than 40%.										
22 I MTR2=30A	G8.22 / Dual setting rated motor current	1 to 1200A	*	Set the nominal current of the motor. This is necessary for correct motor protection. <u>Adjust:</u> Set this value according to rated (nameplate) motor current.										
23 V MTR2=2	G8.23 / setting rated Motor Voltage	1 to 4	2	Adjust nominal motor voltage. <table border="1" data-bbox="965 1462 1209 1592"> <thead> <tr> <th>OPT.</th> <th>DESCRIPTION</th> </tr> </thead> <tbody> <tr> <td>1</td> <td>220-240V</td> </tr> <tr> <td>2</td> <td>380-440V</td> </tr> <tr> <td>3</td> <td>460-525V</td> </tr> <tr> <td>4</td> <td>660-690V</td> </tr> </tbody> </table> <u>Adjust:</u> Set this parameter according to input voltage at the soft starter input. Make sure this value is also relevant for the rated (Nameplate) motor voltage.	OPT.	DESCRIPTION	1	220-240V	2	380-440V	3	460-525V	4	660-690V
OPT.	DESCRIPTION													
1	220-240V													
2	380-440V													
3	460-525V													
4	660-690V													
24 P MTR 2 =4.0kW	G8.24 Dual setting rated motor power	4 to 999kW	*	Set the nominal motor power rating.										
25 COS PHI 2 =85%	G8.25 / Dual setting motor power factor	40 to 99%	85%	Set the rated (nameplate) motor cos phi to for calculating the instantaneous torque developed by the motor.										
6 FREQ 2= 50Hz	G8.26 / Dual setting supply frequency	50Hz 50/60Hz	50Hz	Set the mains frequency. <u>Adjust:</u> Where the mains frequency is 50Hz, leave as default. Where the mains frequency is unknown or different than 50Hz (60Hz) set 50/60Hz. Note: When you set 50/60Hz the SS7 starts an algorithm to detect the mains frequency. This algorithm is off when setting 50Hz.										

* This value depends on the rated current of the softstarter.

11.9. Group 9 – G9: COMPARATOR

Screen	Name / Description	Range	Default Value	Function																				
1 COMP1 SEL=1	G9.1 / Comparator 1 source selection	0 to 8	1	Comparator 1 source selection. <table border="1" style="margin-left: 20px;"> <thead> <tr> <th>OPT.</th> <th>DESCRIPTION</th> </tr> </thead> <tbody> <tr><td>0</td><td>UNUSED</td></tr> <tr><td>1</td><td>MOTOR CURRENT</td></tr> <tr><td>2</td><td>MOTOR POWER</td></tr> <tr><td>3</td><td>MOTOR TORQUE</td></tr> <tr><td>4</td><td>COSINUS PHI</td></tr> <tr><td>5</td><td>INPUT VOLTAGE</td></tr> <tr><td>6</td><td>ANALOG INPUT 1</td></tr> <tr><td>7</td><td>ANALOG INPUT 2</td></tr> <tr><td>8</td><td>O/LOAD STATUS</td></tr> </tbody> </table>	OPT.	DESCRIPTION	0	UNUSED	1	MOTOR CURRENT	2	MOTOR POWER	3	MOTOR TORQUE	4	COSINUS PHI	5	INPUT VOLTAGE	6	ANALOG INPUT 1	7	ANALOG INPUT 2	8	O/LOAD STATUS
OPT.	DESCRIPTION																							
0	UNUSED																							
1	MOTOR CURRENT																							
2	MOTOR POWER																							
3	MOTOR TORQUE																							
4	COSINUS PHI																							
5	INPUT VOLTAGE																							
6	ANALOG INPUT 1																							
7	ANALOG INPUT 2																							
8	O/LOAD STATUS																							
2 COMP1 ON=100%	G9.2 / Comparator 1 ON set point	0 to 500%	100%	Set the comparator ON set point. If the value of the source selected is higher than the ON set point for the time specified at G9.4, the output state of this comparator changes to ON. One of these relays must be selected as a comparator, see screens group G7. Adjust: It sets in % of the selected source (G9.1).																				
3 COMP1 OFF=80%	G9.3 / Comparator 1 OFF set point	0 to 500%	80%	Set the comparator OFF set point. If the value of the source selected is lower than this OFF set point for the time specified at G9.4 the output of this comparator changes to OFF. One of these relays must be selected as a comparator, see screen group G7. Adjust: It sets in % of the selected source (G9.1).																				
4 T COMP1 ON=5s	G9.4 / Comparator 1 ON delay	0 to 99s	5s	Set the ON delay condition for the comparator.																				
5 T COMP1 OFF=5s	G9.5 / Comparator 1 OFF delay	0 to 99s	5s	Set the OFF delay condition for the comparator.																				

EXAMPLE: When motor current exceeds rated current a relay could be used to warn against motor overload.

G9.1 COMP1 SEL= 1 (The selected source is motor current)
 G9.2 COMP1 ON = 100%
 G9.3 COMP1 OFF = 80%
 G9.4 TCMP1 ON = 10s
 G9.5 TCMP1 OFF = 10s
 G7.1 REL1 SEL = 6 (Set as comparator 1)

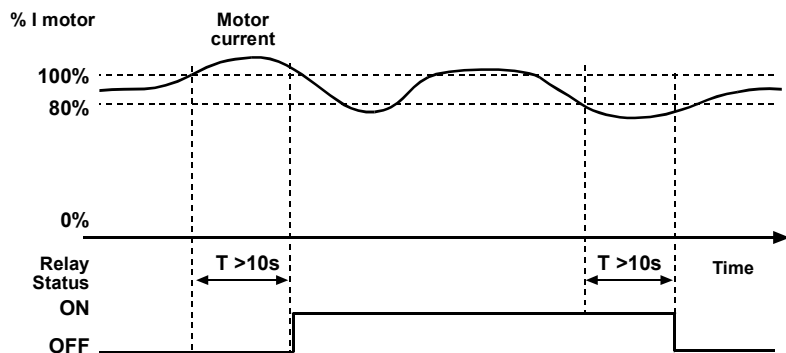

DT0037B

Figure 11.7 Comparator relay configuration.

Screen	Name / Description	Range	Default Value	Function
6 COMP2 SEL=1	G9.6 / Comparator 2 source selection	0 to 8	1	See table in parameter G9.1.
2 COMP2 ON=100%	G9.7 Comparator 2 ON set point	0 to 500%	100%	Set the comparator ON set point. If the value of the source selected is higher than the ON set point for the time specified at G9.4, the output state of this comparator changes to ON. One of these relays must be selected as a comparator, see screens group G7. <u>Adjust:</u> It is set in % of the selected source (G9.6).
8 COMP2 OFF=80%	G9.8 / Comparator 2 OFF set point	0 to 500%	80%	Set the comparator OFF set point. If the value of the source selected is lower than this OFF set point for the time specified at G9.10 the output of this comparator changes to OFF. One of these relays must be selected as a comparator, see screen group G7. <u>Adjust:</u> It is set in % of the selected source (G9.6).
9 T COMP2 ON=5s	G9.9 / Comparator 2 ON delay	0 to 99s	5s	Set the ON delay condition for the comparator 2
10 TCMP2 OFF=5s	G9.10 / Comparator 2 OFF delay	0 to 99s	5s	Set the OFF delay condition for the comparator 2.
11 SELEC COMP3=1	G9.11 / Comparator 3 source selection	0 to 8	1	See table in parameter G9.1.
12 COMP3 ON=100%	G9.12 / Comparator 3 ON set point	0 to 500%	100%	Set the comparator ON set point. If the value of the source selected is higher than the ON set point for the time specified at G9.14, the output state of this comparator changes to ON. One of these relays must be selected as a comparator, see screens group G7. <u>Adjust:</u> It is set in % of the selected source (G9.11).
13 CMP3 OFF=80%	G9.13 / Comparator 3 OFF set point	0 to 500%	80%	Set the comparator OFF set point. If the value of the source selected is lower than this OFF set point for the time specified at G9.14 the output of this comparator changes to OFF. One of these relays must be selected as a comparator, see screen group G7. <u>Adjust:</u> It is set in % of the selected source (G9.11).
14 TCMP3 ON=5s	G9.14 / Comparator 3 ON delay	0 to 99s	5s	Set the ON delay condition for the comparator 3.
15 TCMP3 OFF=5s	G9.15 / Comparator 3 OFF delay	0 to 99s	5s	Set the OFF delay condition for the comparator 3.

11.10.Group 10 – G10: FAULT HISTORY

Screen	Name / Description	Range	Default Value	Function
1 NO FAULT	G10.1 / Register 1 of fault history	-	-	<p>The last fault will be displayed as following table indicates by pressing the " * " key.</p> <p><u>Function:</u> Shows the last fault the soft starter tripped on. When a fault occurs, the soft starter automatically shows this screen. At the same time, the fault led lights up. This fault may be reset by pressing the STOP-RESET button on the display unit (if enabled) or using an externally configured RESET input.</p> <p><u>Example:</u> When fault occurs led red will light and status line (upper line) will show FLT. The average current and voltage displayed are the values right when fault occurred.</p> <p>Last line will show the fault name and the status of SS7 when the fault occurred separated by " / " in case automatic reset was no activated, or by ":" in case it was activated</p> <p>If " * " key is pressed it will display the position of the fault in the history and the number related to it.</p> <p>Note: See next page.</p>

Screen	Name / Description	Range	Default Value	Function																																																												
1 NO FAULT	G10.1 / Register 1 of fault history	-	-	<p>Note: Coming from previous page.</p> <p>Next, the faults are listed:</p> <table border="1"> <thead> <tr> <th>COD</th> <th>FAULT</th> <th>COD</th> <th>FAULT</th> </tr> </thead> <tbody> <tr> <td>F0</td> <td>NO FAULT</td> <td>F14</td> <td>SCR1 FAULT</td> </tr> <tr> <td>F1</td> <td>PHA MISING</td> <td>F15</td> <td>SCR2 FAULT</td> </tr> <tr> <td>F2</td> <td>WRONG PH/SQ</td> <td>F16</td> <td>SCR3 FAULT</td> </tr> <tr> <td>F3</td> <td>ASYM CURR</td> <td>F17</td> <td>SCR_S FLT</td> </tr> <tr> <td>F4</td> <td>OVER LOAD</td> <td>F18</td> <td>EXCES T LS</td> </tr> <tr> <td>F5</td> <td>UNDER LOAD</td> <td>F19</td> <td>LS DISABLE</td> </tr> <tr> <td>F6</td> <td>PEAK CURR</td> <td>F20</td> <td>COMS T/OUT</td> </tr> <tr> <td>F7</td> <td>STARTER OT</td> <td>F21</td> <td>EXTRN TRIP</td> </tr> <tr> <td>F8</td> <td>MOTOR PTC</td> <td>F22</td> <td>CUR FLT</td> </tr> <tr> <td>F9</td> <td>SHEAR PIN</td> <td>F23</td> <td>CUR FLT2</td> </tr> <tr> <td>F10</td> <td>OVER VOLT</td> <td>F24</td> <td>HIGH PRESSURE</td> </tr> <tr> <td>F11</td> <td>UNDER VOLT</td> <td>F25</td> <td>LOW PRESSURE</td> </tr> <tr> <td>F12</td> <td>EXCESIV STR</td> <td>F26</td> <td>FLOW SWITCH</td> </tr> <tr> <td>F13</td> <td>MEMORY FLT</td> <td>F27</td> <td>DEEP WELL PROBE</td> </tr> </tbody> </table>	COD	FAULT	COD	FAULT	F0	NO FAULT	F14	SCR1 FAULT	F1	PHA MISING	F15	SCR2 FAULT	F2	WRONG PH/SQ	F16	SCR3 FAULT	F3	ASYM CURR	F17	SCR_S FLT	F4	OVER LOAD	F18	EXCES T LS	F5	UNDER LOAD	F19	LS DISABLE	F6	PEAK CURR	F20	COMS T/OUT	F7	STARTER OT	F21	EXTRN TRIP	F8	MOTOR PTC	F22	CUR FLT	F9	SHEAR PIN	F23	CUR FLT2	F10	OVER VOLT	F24	HIGH PRESSURE	F11	UNDER VOLT	F25	LOW PRESSURE	F12	EXCESIV STR	F26	FLOW SWITCH	F13	MEMORY FLT	F27	DEEP WELL PROBE
COD	FAULT	COD	FAULT																																																													
F0	NO FAULT	F14	SCR1 FAULT																																																													
F1	PHA MISING	F15	SCR2 FAULT																																																													
F2	WRONG PH/SQ	F16	SCR3 FAULT																																																													
F3	ASYM CURR	F17	SCR_S FLT																																																													
F4	OVER LOAD	F18	EXCES T LS																																																													
F5	UNDER LOAD	F19	LS DISABLE																																																													
F6	PEAK CURR	F20	COMS T/OUT																																																													
F7	STARTER OT	F21	EXTRN TRIP																																																													
F8	MOTOR PTC	F22	CUR FLT																																																													
F9	SHEAR PIN	F23	CUR FLT2																																																													
F10	OVER VOLT	F24	HIGH PRESSURE																																																													
F11	UNDER VOLT	F25	LOW PRESSURE																																																													
F12	EXCESIV STR	F26	FLOW SWITCH																																																													
F13	MEMORY FLT	F27	DEEP WELL PROBE																																																													
2 NO FAULT	G10.2 / Register 2 of fault history	-	-																																																													
3 NO FAULT	G10.3 / Register 3 of fault history	-	-																																																													
4 NO FAULT	G10.4 / Register 4 of fault history	-	-																																																													
5 NO FAULT	G10.5 / Register 5 of fault history	-	-																																																													
6 DELET FAULTS=N	G10.6 / Clear history fault	Y N	N	<p>Clear the fault history log which resets the above screens back to the default setting NO FAULTS.</p> <p>Adjust: Select YES (Y) to clear the fault history log. The screen will automatically reset back to the default value NO (N) once the fault history is cleared.</p>																																																												

11.11.Group 11 – G11: STATISTICS

Screen	Name / Description	Range	Default Value	Function
1 STARTS1 00000	G11.1 Total number of starts	-	-	Shows the total number of the SS7 starts. This record cannot be reset to zero.
2 STARTS2 00000	G11.2 / Counter of starts 2	-	-	Shows the number of the SS7 starts made after G11.3 has been cleared. This parameter can be reset to zero.
3 DEL STARTS2=NO	G11.3 Clears counter of starts 2	-	-	It resets to 0 the number of starts displayed in G11.2.
4 H1 =00000h:00m	G11.4 / Total of working hours	-	-	Shows the total soft starter operation hours. This record cannot be reset to zero.
5 H2= 00000h:00m	G11.5 / Total of working hours	-	-	Shows the total soft starter operation hours. This record cannot be reset to zero.
6 DEL HOURS2=NO	G11.6 / Working hours counter 2	-	-	Shows the number of the SS7 operations hours made G11.6 has been cleared.
7 TOTAL FLT=00	G11.7 Total number of faults counter	-	-	Shows the total number where the SS7 has tripped due to faults.
8 FAULT 2=0	G11.8 / Faults counter 2	-	-	Shows the number of faults occurred after G11.9 has been cleared. This parameter cannot be reset to zero
9 DEL FAULT2=NO	G11.9 / Clear faults counter 2	-	-	Resets to 0 the number of faults displayed in G11.8
10 KWH=000000	G11.10 / Total number of KWH done by the SS7	-	-	Shows the total value of KWH done by the SS7. This parameter cannot be reset to zero.

11.12.Group 12 – G12: SLOW SPEED

The SS7 can work at slow speed mode in three different ways:

1. **From keypad:** Set screen G6.1 to MODE 4 (LOCAL JOG-JOG+), by pressing START, the motor will turn at slow speed (+), and when pressing stop motor will turn at slow speed (-).
2. **From digital inputs:** Any of the digital inputs can be set to 6 for the motor to run at (+) slow speed or to option 7 for the motor to run at (-) slow speed.
3. **Automatic:** By this operation mode, when providing start command the SS7 will execute the following sequence. First it will turn at (+) slow speed during the time set in screen G12.4, then it will accelerated to nominal speed and after stop command it will run at (-) slow speed during the time set in screen G12.5 after deceleration.

Slow speed will be used only for short time motor positioning operation.

Screen	Name / Description	Range	Default Value	Function						
1 L/S ACC-DEC =N	G12.1 / Slow speed mode	Y N	NO	Enable/Disable slow speed during the acceleration/deceleration. <table border="1"> <thead> <tr> <th>OPTION</th> <th>FUNCTION</th> </tr> </thead> <tbody> <tr> <td>Y=YES</td> <td>Slow speed mode enabled.</td> </tr> <tr> <td>N=NO</td> <td>Slow speed mode disabled.</td> </tr> </tbody> </table> <i>Adjust:</i> When slow speed is not required set to 0. Otherwise, set to 1.	OPTION	FUNCTION	Y=YES	Slow speed mode enabled.	N=NO	Slow speed mode disabled.
OPTION	FUNCTION									
Y=YES	Slow speed mode enabled.									
N=NO	Slow speed mode disabled.									
2 L SPD TORQ =30%	G12.2 / Slow Speed Torque	30 to 99%	30%	Provides the torque applied to the motor during slow speed process. <i>Adjust:</i> The level depends on the load. Start at low values and increase until the motor operates at slow speed mode						
3 L.S MAX T =0s	G12.3 / Slow Speed Timeout	0 to 60s	0s	Timeout condition while working at slow speed. When exceeded, the soft starter will trip on F18 Timeout slow Speed. <i>Adjust:</i> Therefore a maximum slow speed time operation must be set if slow speed is required, to protect both motor and soft starter and enabling tripping on F18.						
4 L.S ACL T=0s	G12.4 / Slow Speed Acceleration Time	0 to 60s, OFF	0s	Run time at slow speed before the ramp up starts. <i>Adjust:</i> the required time for the motor to work at slow speed before accelerating.						
5 L.S DEC T=0s	G12.5 / Slow speed Deceleration Time	0 to 60s, OFF	0s	Run time at slow speed after deceleration. <i>Adjust:</i> the required time for the motor to work at slow speed after decelerating.						

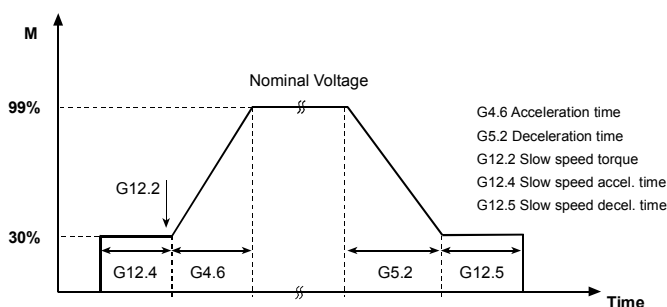

Figure 11.8 Work at slow speed in auto mode

11.13.Group 13 – G13: DC BRAKE

Screen	Name / Description	Range	Default Value	Function						
1 DC BRAK SEL=N	G13.1 / DC Brake selection	Y N	N	Enable/Disable DC brake. This option, will enable a continuous current to be applied for a determined torque (G13.2) and for a determined time (G13.3).when the deceleration ramp is complete. <u>Applications:</u> Ball mills, motor shaft positioning. <u>Note:</u> high inertia applications, an external DC brake unit could be required.						
2 DC BRAK I=50%	G13.2 / DC Current injection	30 to 99%	50%	Set the DC current to be applied to the motor. It must be considered that the brake energy dissipates entirely in the motor. A stop with high DC current or a stop that lasts for too long may cause overheating of the motor. <u>Adjust:</u> It is sets in % of the achievable torque.						
3 DC BRAKE T =0s	G13.3 / DC Brake time	0 to 99s	0s	Sets the time for the DC current to be applied. <u>Adjust:</u> The stopping rate of a motor using DC Brake current injection depends on the DC current applied (G13.2) for a preset time (G13.3). The adjustments of these 2 variables and the inertia of the system will determine the deceleration time of the motor. Applying an excessive brake current could cause overheating of the motor – The same applies if the DC injection time is too long. However lower current or shorter time than necessary may not stop the motor as required						
4 EXTERNAL B=N	G13.4 / Enables external Brake unit at output relay 3	Y N	N	This Parameter sets the SS7 to work with an external brake unit. Relay 3 is dedicated to control the Brake Unit activation. See screen G7.3. <table border="1"> <thead> <tr> <th>OPTION</th> <th>FUNCTION</th> </tr> </thead> <tbody> <tr> <td>Y=YES</td> <td>External braking unit is used.</td> </tr> <tr> <td>N=NO</td> <td>External braking unit is not used.</td> </tr> </tbody> </table> <u>Applications:</u> Mills, centrifuges and loads with big inertia. <u>Note:</u> For applications with big inertia, it is probably the user must use the external braking unit.	OPTION	FUNCTION	Y=YES	External braking unit is used.	N=NO	External braking unit is not used.
OPTION	FUNCTION									
Y=YES	External braking unit is used.									
N=NO	External braking unit is not used.									

11.14.Group 14 – G14: SERIAL COMMUNICATION

Screen	Name / Description	Range	Default Value	Function						
1 COM TIME O=OFF	G14.1 Serial Communication Timeout	OFF, 0 to 25s	OFF	Timeout condition for serial communication. When the time without communication exceeds this parameter the soft starter will trip by F20 Communication Timeout.. <u>Adjust:</u> This timeout is used to detect the loss of this communication between master – slave. The SS7 stops the motor until the communication is re-established and reset. In certain cases continuous communication is necessary.						
2 COM ADDRESS=10	G14.2 / Modbus Device Address	0 to 240	10	It sets the Modbus address for the equipment into a network.						
3 BAUD RATE=9600	G14.3 / Modbus Communication Baud Rate	OFF 1200 2400 4800 9600	9600 (Baudis)	Set the baud rate for Serial Communication.						
4 EVEN PARITY=N	G14.4 / Modbus communication parity	Y N	N	Selects the parity fro serial communication. <table border="1"> <thead> <tr> <th>OPTION</th> <th>FUNCTION</th> </tr> </thead> <tbody> <tr> <td>Y=YES</td> <td>Even parity enabled.</td> </tr> <tr> <td>N=NO</td> <td>No parity.</td> </tr> </tbody> </table> <u>Adjust:</u> Parity setting of the softstarter should match with the parity of the bus master into the network.	OPTION	FUNCTION	Y=YES	Even parity enabled.	N=NO	No parity.
OPTION	FUNCTION									
Y=YES	Even parity enabled.									
N=NO	No parity.									

11.15.Group 15 – G15: AUTO RESET

This group enables SS7 to be automatically reset. Once reset is done, the SS7 will start again in case the fault occurred during start command, acceleration and run. If the fault occurred in ready status “RDY” it will autoreset and comes back to “RDY” again.

Screen	Name / Description	Range	Default Value	Function																																																
1 AUTO RESET=NO	G15.1 / Automatic Reset	YES NO	NO	Enable / Disable SS7 automatic reset function.																																																
2 ATTEMP NUMBR=5	G15.2 Number of auto reset attempts before tripping due to fault	1 to 5	5	Provides the number of attempts to reset the SS7 before it trips.																																																
3 R STR DEL=5s	G15.3 / Delay time from fault event to auto reset	5 to 120s	5s	Allows the user to select the period of time between the fault trip and the auto reset.																																																
4 RS COUNT=15Min	G15.4 / Time after the attempt counter will be reset	1 to 60Min	15Min	It allows to select the time the SS7 has to run without fault and after this the internal attempt counter will be reset.																																																
5 F1 AUTO RST=0	G15.5 / Auto reset fault 1 selection	0 to 20	0	It selects fault no1 for the auto reset mode. <table border="1" style="margin: 10px auto;"> <thead> <tr> <th>FAULT</th> <th>FAULT LIST</th> <th>FAULT</th> <th>FAULT LIST</th> </tr> </thead> <tbody> <tr> <td>0</td> <td>NO AUTO RESET</td> <td>11</td> <td>SCR_1 FAULT</td> </tr> <tr> <td>1</td> <td>PHAS MISING</td> <td>12</td> <td>SCR_2 FAULT</td> </tr> <tr> <td>2</td> <td>WRONG PH/SQ</td> <td>13</td> <td>SCR_3 FAULT</td> </tr> <tr> <td>3</td> <td>ASYM CURR</td> <td>14</td> <td>SCR_3 FLT</td> </tr> <tr> <td>4</td> <td>OVER LOAD</td> <td>15</td> <td>EXCESIV LS T</td> </tr> <tr> <td>5</td> <td>UNDER LOAD</td> <td>16</td> <td>COMMS T/OUT</td> </tr> <tr> <td>6</td> <td>STARTER OVT</td> <td>17</td> <td>EXTERN TRIP</td> </tr> <tr> <td>7</td> <td>MOTOR PTC</td> <td>18</td> <td>CUR FLT</td> </tr> <tr> <td>8</td> <td>SHEAR PIN</td> <td>19</td> <td>CUR2 FLT</td> </tr> <tr> <td>9</td> <td>OVER VOLT</td> <td>20</td> <td>ALL THE FLTS</td> </tr> <tr> <td>10</td> <td>UNDER VOLT</td> <td></td> <td></td> </tr> </tbody> </table> Note: Option 20 will automatically reset any of the above table faults.	FAULT	FAULT LIST	FAULT	FAULT LIST	0	NO AUTO RESET	11	SCR_1 FAULT	1	PHAS MISING	12	SCR_2 FAULT	2	WRONG PH/SQ	13	SCR_3 FAULT	3	ASYM CURR	14	SCR_3 FLT	4	OVER LOAD	15	EXCESIV LS T	5	UNDER LOAD	16	COMMS T/OUT	6	STARTER OVT	17	EXTERN TRIP	7	MOTOR PTC	18	CUR FLT	8	SHEAR PIN	19	CUR2 FLT	9	OVER VOLT	20	ALL THE FLTS	10	UNDER VOLT		
FAULT	FAULT LIST	FAULT	FAULT LIST																																																	
0	NO AUTO RESET	11	SCR_1 FAULT																																																	
1	PHAS MISING	12	SCR_2 FAULT																																																	
2	WRONG PH/SQ	13	SCR_3 FAULT																																																	
3	ASYM CURR	14	SCR_3 FLT																																																	
4	OVER LOAD	15	EXCESIV LS T																																																	
5	UNDER LOAD	16	COMMS T/OUT																																																	
6	STARTER OVT	17	EXTERN TRIP																																																	
7	MOTOR PTC	18	CUR FLT																																																	
8	SHEAR PIN	19	CUR2 FLT																																																	
9	OVER VOLT	20	ALL THE FLTS																																																	
10	UNDER VOLT																																																			
6 F2 AUTO RST=0	G15.6 / Auto reset fault 2 selection	0 to 20	0																																																	
7 F3 AUTO RST=0	G15.7 / Auto reset fault 3 selection	0 to 20	0																																																	
8 F4 AUTO RST=0	G15.8 / Auto reset fault 4 selection	0 to 20	0																																																	

11.16.Group 16 – G16: PUMP CONTROL 1

Screen	Name / Description	Range	Default Value	Function
1 SET IT=000Hrs	G16.1 / Irrigation time adjustment	0.0 to 60.0Hrs, INF	INF	Sets the time for the system to be irrigating. Adjust: SS7 irrigation timer can be reset (G16.2 back to 0Hrs.) by decreasing G16.1 to the same value than G16.2.
2 I TIME=000Hrs	G16.2 / Irrigation time display	0.0 to 60.0Hrs, INF	-	Displays the time the system has been irrigating. Note: Read only screen.

Screen	Name / Description	Range	Default Value	Function						
3 START MODE = 0	G16.3 / Start mode selection	0 – 1	0	<p>Selects the start mode of the system.</p> <p>Adjust:</p> <table border="1"> <thead> <tr> <th>OPTION</th> <th>FUNCTION</th> </tr> </thead> <tbody> <tr> <td>0</td> <td> <p>Display unit: Enables the display unit for start stop control of the SS7. This is the only way in which the SS7 can be started or stopped. Digital inputs are preconfigured as follows:</p> <p>D INPUT 1. High Pressure switch connection (normally closed). D INPUT 2. Low Pressure switch connection (normally closed). D INPUT 3 Flow switch connection (normally closed). D INPUT 4 Deep well probe connection (normally closed). D INPUT 5 Trip (normally closed).</p> </td> </tr> <tr> <td>1</td> <td> <p>Wire: (Face Plate stop button is Reset only). Remaining digital inputs are preconfigured as follows:</p> <p>D INPUT 1 High Pressure switch connection (normally closed). D INPUT 2 Low pressure switch connection (normally closed). D INPUT 3 Flow switch connection (normally closed). D INPUT 4 Deep well probe connection (normally closed). D INPUT 5 is configured for remote two wire start/stop. This input acts as a reset command on closing edge.</p> </td> </tr> </tbody> </table>	OPTION	FUNCTION	0	<p>Display unit: Enables the display unit for start stop control of the SS7. This is the only way in which the SS7 can be started or stopped. Digital inputs are preconfigured as follows:</p> <p>D INPUT 1. High Pressure switch connection (normally closed). D INPUT 2. Low Pressure switch connection (normally closed). D INPUT 3 Flow switch connection (normally closed). D INPUT 4 Deep well probe connection (normally closed). D INPUT 5 Trip (normally closed).</p>	1	<p>Wire: (Face Plate stop button is Reset only). Remaining digital inputs are preconfigured as follows:</p> <p>D INPUT 1 High Pressure switch connection (normally closed). D INPUT 2 Low pressure switch connection (normally closed). D INPUT 3 Flow switch connection (normally closed). D INPUT 4 Deep well probe connection (normally closed). D INPUT 5 is configured for remote two wire start/stop. This input acts as a reset command on closing edge.</p>
OPTION	FUNCTION									
0	<p>Display unit: Enables the display unit for start stop control of the SS7. This is the only way in which the SS7 can be started or stopped. Digital inputs are preconfigured as follows:</p> <p>D INPUT 1. High Pressure switch connection (normally closed). D INPUT 2. Low Pressure switch connection (normally closed). D INPUT 3 Flow switch connection (normally closed). D INPUT 4 Deep well probe connection (normally closed). D INPUT 5 Trip (normally closed).</p>									
1	<p>Wire: (Face Plate stop button is Reset only). Remaining digital inputs are preconfigured as follows:</p> <p>D INPUT 1 High Pressure switch connection (normally closed). D INPUT 2 Low pressure switch connection (normally closed). D INPUT 3 Flow switch connection (normally closed). D INPUT 4 Deep well probe connection (normally closed). D INPUT 5 is configured for remote two wire start/stop. This input acts as a reset command on closing edge.</p>									
4 HI PR DEL=00s	G16.4 / High pressure timeout	0 to 60s	0s	<p>This is the time delay before the SS7 trips once the high pressure switch connection opens (D INPUT 1). Note: SS7 ramps down to stop.</p>						
5 L PR DEL=0000s	G16.5 / Low pressure timeout	0 to 3600s	20s	<p>This is the time delay before the SS7 trips once the low pressure switch connection opens (D INPUT 2). Note: SS7 ramps down to stop.</p>						
6 L PR BYP=0000s	G16.6 / Low pressure start bypass time	0 to 1800s (30min)	10s	<p>Sets the start bypass time, during which the SS7 starter ignores the Low Pressure input (D INPUT 2).</p>						
7 FLO BYP=0000s	G16.7 / No Flow Start Bypass time	0 to 1800s	10s	<p>Sets the time period for which the flow switch input is ignored following a start command (D INPUT 3).</p>						
8 FLO DEB=00s	G16.8 / No Flow Debounce Delay	0 to 60s	10s	<p>Sets the delay period before the starter responds to a no flow signal when in normal run operation. (D INPUT 3). Note: SS7 ramps down to stop.</p>						
9 LO WTR DEL=00s	G16.9 / Deep Well Probe Delay	0 to 60s	10s	<p>Sets the delay period before the starter stops after receiving a valid deep well probe signal. (D INPUT 4). Note: SS7 ramps freewheel stops.</p>						

12. FAULT MESSAGES. DESCRIPTION AND ACTIONS

FAULT TRIPS

When a fault occurs, the SS7 will stop the motor and will display the fault that caused the trip. The red LED and fault message will remain until the fault has been removed and the soft starter is reset. To reset the SS7 either press the (Stop/Reset) key or operate an external reset, by closing a normally open contact (NO), configured to any of the digital inputs of the SS7.

Fault Description Possible Cause Action	F0 NO FAULTS No fault detected. Normal operation. None required.
Fault Description Possible Cause Action	F1 PHA MISING Supply phase loss. Loss of phase, fuse failure, cable fault, motor winding fault. Check supply, all cables, and motor. If the problem persists, call LS or an authorised distributor.
Fault Description Possible Cause Action	F2 WRONG PH / SQ Incorrect input supply phase sequence. The mains phase sequence doesn't correspond to G3.1 (1 PHASE SEQUEN=2) Swap two input phase over or change G3.1 Phase Sequence to suit supply phase sequence.
Fault Description Possible Cause Action	F3 ASYM CURR Phase current imbalance. There is a current imbalance higher than 40%. Check the motor; check the load and the coupling between both. Check input power supply is always balanced. Check thyristors. If the problem persists, call LS or an authorised distributor.
Fault Description Possible Cause Action	F4 OVER LOAD. Calculated motor overload has reached an unacceptable level. Motor overload. If the trip is produced during start, it could be a mechanical problem. If it occurs when the motor is running at nominal speed, probable causes could be a wrong setting at G.3.2. screen or a change of the load conditions. Wrong nameplate values. Check that current from the G3.2 screen is the same as the motor. Check working conditions of motor. Check load. Check nameplates. If the trip is occurring during the start: Check mechanical conditions. Check there is not a power input supply voltage drop greater than 10%. Increase acceleration ramp (high inertia applications). Increase overload curve in G3.3 screen. Increase current limit.
Fault Description Possible Cause Action	F5 UNDER LOAD. Motor under load. Motor current draw is lower than that set in G3.6 screen. Soft starter has been working during for longer than the one set in G3.7 screen. Motor working with no load. Wrong setting of under load conditions. Check that mechanical parts coupled to the motor are ok and that the motor is not working unloaded. In case of pump application, check there is no air inside the pipe network and that the pump suction is not obstructed. Wrong adjustment, set again under load settings G3.6 and G3.7.

Fault	F6 PEAK CURR
Description	SS7 peak current output exceeded. The current is higher than six times nominal.
Sense level	(6xIn). SS7 Rated Current.
Possible Cause	Rotor locked. Short circuit in output circuit. SS7 current transformers failure. Torque pulse setting too high.
Action	Check cables and motor. Reduce Torque pulse setting. If the problem persists, call LS or an authorised distributor.
Fault	F7 STARTER OT
Description	Heat sink too hot (>85°C).
Sense level	(> 85°C).
Possible Cause	Insufficient cooling. Fan failure. Ambient temperature too high (>45°C). The actual current is higher than the nominal.
Action	Check fans and cooling paths. Check the ambient temperature during normal operation doesn't exceed 45°C or 50°C with re-rating. Check that correct re-rating has been applied if higher than 45°C. Check that actual motor current is the same or smaller than the SS7 nominal current.
Fault	F8 MOTOR PTC .
Description	External trip (Motor PTC) has operated (Terminals T16-T17).
Sense level	150ohms<PTC <2.7kohms >>ok. other >> fault.
Possible Cause	Motor over temperature. Fault in sensor wiring (open-circuit, short-circuit)
Action	Check motor is not overloaded. Check PTC wiring, check PTC. If there is no PTC connected, select G3.5 MOTOR PTC=NO
Fault	F9 SHEARPIN
Description	Shearpin current trip.
Sense level	G3.8 Shearpin Current.
Possible Cause	The motor has drawn a higher current than Shearpin protection setting at G3.8. Rotor locked due to a mechanical obstruction.
Action	Check if it's possible that motor reaches the Shearpin current under normal operation, and if so, increase the value of that protection. Check motor, cables and load and the reason of the over current.
Fault	F10 OVER VOLT
Description	High supply voltage for too long period.
Sense level	The combination of parameters G3.12 OVERVOLTAGE and G3.13 OVERVOLTAGE DELAY.
Possible Cause	Fluctuating power supply, wrong settings; the input voltage of each phase in parameter G3.12; and the time set in G3.13.
Action	Check supply voltage and set G3.12 and G3.13. Check supply.
Fault	F11 UNDER VOLT
Description	Low voltage supply for too long period.
Sense level	The combination of parameters G3.10 UNDERVOLTAGE and G3.11 UNDERVOLTAGE DELAY.
Possible Cause	Impedance of input power supply is too high. Excess current draw, weak supply. Check the input voltage of each phase is higher than G3.10 parameter and during the time set in G3.11 parameter.
Action	Check supply, check values at G3.10 and G3.11. Check supply.

<p>Fault</p> <p>Description</p> <p>Sense level</p> <p>Possible Cause</p> <p>Action</p>	<p>F12 EXCESIV STR</p> <p>Maximum number of starts exceeded.</p> <p>Maximum number of starts set at G3.14 START LIMIT during time period set at G3.15 SRT/INT.</p> <p>Excessive number of starts/stop during the normal operation. Rotor locked or motor overloaded during the start so the ramp up couldn't be completed.</p> <p>Check motor and load conditions. Check values of parameters G3.14, G3.15 are coherent with the application.</p>
<p>Fault</p> <p>Description</p> <p>Possible Cause</p> <p>Action</p>	<p>F13 MEMORY FLT</p> <p>Fault reading SRAM.</p> <p>Writing error, faulty memory.</p> <p>Attempt to reinitialise the SS7 (1.5 INITIALISE) .</p> <p>If the problem persists, call LS or an authorised distributor.</p>
<p>Fault</p> <p>Description</p> <p>Possible Cause</p> <p>Action</p>	<p>F14 SCR1 FAULT</p> <p>F15 SCR2 FAULT</p> <p>F16 SCR3 FAULT</p> <p>F17 SCR_S FLT</p> <p>F14 Thyristor Fault L1, disconnected motor at L1. F15 Thyristor Fault L2, disconnected motor at L2. F16 Thyristor Fault L3, disconnected motor at L3. F17 Thyristors Fault , disconnected motor.</p> <p>Thyristor fault, motor disconnected, excessive number of starts, excessive temperature, over voltage.</p> <p>Check motor, cables and fans. Check thyristors and excessive environmental temperature.</p> <p>Check input supply voltage.</p> <p>If the problem persists, call LS or an authorised distributor.</p>
<p>NOTE:</p>	<p><i>This fault can only be reset via the display unit.</i></p>
<p>Fault</p> <p>Description</p> <p>Sense level</p> <p>Possible Cause</p> <p>Action</p>	<p>F18 EXCES T LS</p> <p>Slow speed working time exceeded.</p> <p>G12.3 L.S MAX T.</p> <p>Excessive running time at slow speed.</p> <p>Check the control. Check value of parameter G12.3.</p>
<p>Fault</p> <p>Description</p> <p>Possible Cause</p> <p>Action</p>	<p>F19 LS DISABLE</p> <p>Slow Speed not allowed.</p> <p>Slow Speed mode is blocked if one of these 2 options are selected:</p> <ul style="list-style-type: none"> • No phase sequence (G3.1 Phase Sequence) at the input. You need to select L1 L2 L3 or L2 L1 L3 sequence. • DC Brake stop selected (G13.1 DC Brake). <p>Set phase sequence at the input. Make sure no DC Brake is selected.</p>
<p>Fault</p> <p>Description</p> <p>Possible Cause</p> <p>Action</p>	<p>F20 COMS T/OUT</p> <p>Serial communication Time Out exceeded.</p> <p>No communication from the Master for the time specified at G14.1 CommTime Out.</p> <p>RS232/RS485 communication link fault.</p> <p>Check if the Master is trying to communicate to slave at a rate higher than specified at G14.1 COM TIME O. Check the RS232/RS485 wiring. Check communication parameters.</p>
<p>Fault</p> <p>Description</p> <p>Possible Cause</p> <p>Action</p>	<p>F21 EXTRN TRIP</p> <p>An external fault has occurred through a digital input.</p> <p>There is a digital input activated and set as external fault.</p> <p>Check configuration of digital inputs. Check the status of the digital inputs for correctness.</p>

Fault	F22 CUR FLT
Description	Large current unbalance is occurring among phases.
Possible Cause	Large current unbalance occurs due to a sudden voltage drop in any of the SS7 input phases. Possible disconnection of one phase.
Action	Check input power wiring. Check motor connection. Check supply voltage is correct.
NOTE:	<i>In case of working with lamps for testing purposes at the output set the motor current to 1 A to avoid this fault.</i>
Fault	F23 CUR FLT 2
Description	Large current unbalance is occurring among phases.
Possible Cause	Large current unbalance occurs due to a sudden voltage rise in any of the SS7 input phases.
Action	Check input power wiring. Check supply voltage is correct.
Fault	F24 HIGH PRESSURE
Description	High pressure time protection.
Possible Cause	The SS7 is running and the pressure switch opens for longer than the time entered in screen G16.4. Overpressure.
Action	Check hydraulic installation. Check pressure switch. Check proper wiring from pressure switch to SS7 digital input 1. The SS7 will require resetting on the display or via D INPUT 5 if configured for 2 wire start/stop. Check parameter setting is done according to application requirements.
Fault	F25 LOW PRESSURE
Description	Low pressure protection.
Possible Cause	The SS7 is running and the pressure switch opens for longer than the time entered in screen G16.5.
Action	Check hydraulic installation (broken pipes). Check pump has got water. Check pressure switch. Check proper wiring from pressure switch to SS7 digital input 2. The SS7 will require resetting on the display or via D INPUT 5 if configured for 2 wire start/stop. Check parameter setting is done according to application requirements.
Fault	F26 FLOW SWITCH
Description	No flow protection.
Possible Cause	The flow switch is ignored for the time set in screen G16.7 on receipt of a valid start signal. After this time the SS7 will trip if no flow is indicated for longer than the time set in screen G16.8. No water in the pump.
Action	Check proper pump water supply. Check flow switch. Check proper wiring from flow switch to SS7 digital input 3. The SS7 will require resetting on the display or via D INPUT 5 if configured for 2 wire start/stop. Check parameter setting is done according to application requirements.
Fault	F27 DEEP WELL PROBE
Description	Low level protection
Possible Cause	The well probe controller (or other level controller) detects a lack of water. The tank or pump has no water.
Action	Check water level. Check hydraulic installation. Check level switch. Check proper wiring from deep well probe flow controller to SS7 digital input 4. The SS7 will not reset unless the low water fault has been cleared (D INPUT 4 closed). Check parameter setting is done according to application requirements.

13.3. Operation Mode

▪ **Connection Drawing.**

See section '7.1 Control Connection Drawing'.

▪ **Start and Stop from Display.**

Screen 1 of group 6 must be adjusted in local. **G6.1= LOCAL**

With Star-pushbutton the motor will be started and with Stop/Reset-pushbutton the motor will be stopped.

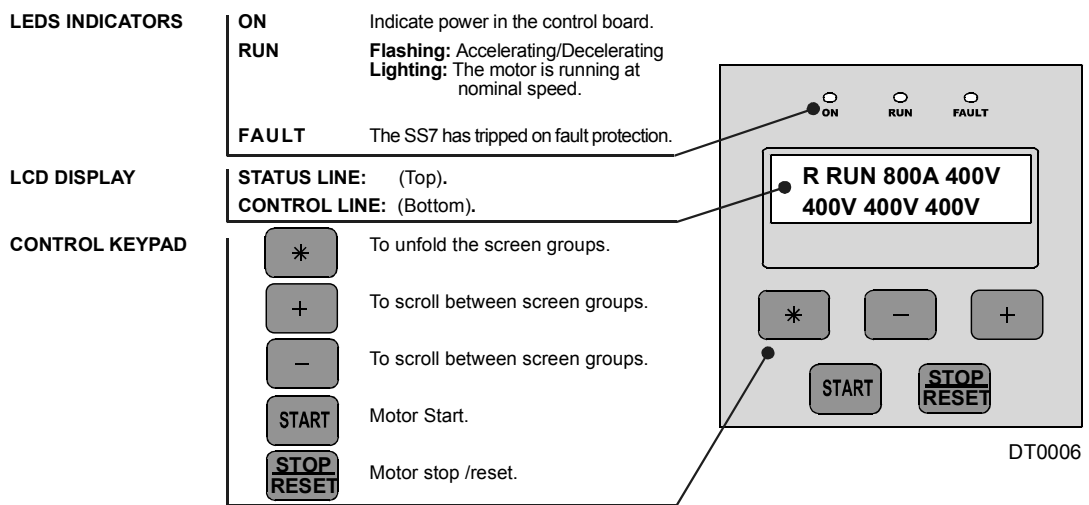

Figure 13.2 Start and stop from Display

▪ **Start and stop using a free potential contact.**

G6.1 = Remote.

G6.3 = 3 DIGITAL INPUT1=4 / START / STOP (T11).

G6.4 = 4 DIGITAL INPUT2=5 / RESET (T12).

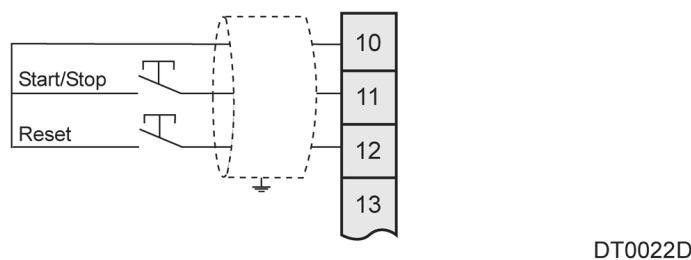

Figure 13.3 Start and stop using a free potential contact

- **Start and Stop using pushbuttons.**

G6.1 = Remote.

G6.3 = 3 DIGITAL INPUT1=1 / START (T11).

G6.4 = 4 DIGITAL INPUT2=2 / STOP (T12).

G6.5 = 5 DIGITAL INPUT3=5 / RESET (T13).

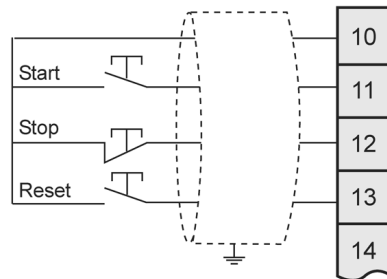

DT0003E

Figure 13.4 Start and stop using pushbuttons

14.CONFIGURATION REGISTER

DIGITAL SOFT STARTER:

SERIAL N°:
APPLICATION :
DATE:
CUSTOMER :

SS7

SERIAL N°:
APPLICATION :
DATE:
CUSTOMER :

SCREENS	RANGE	DEFAULT	RECORD 1	RECORD 2
G1 MENU OPTIONS				
1 LOCK PARAM=	Yes/No	N0		
2 PASSWORD=	0000-9999	0		
3 WRONG P/W=	0000-9999	XXXX		
4 LANGUE=	Span., Eng., D	ENGLISH		
5 INITIALISE=	Yes/No	NO		
6 COMMISSION=	Yes/No	YES		
G2 NAMEPLATE				
1 ISTARTER=	9 - 1600	__ _ A*		
2 I MOTOR=	1 - 1600	__ _ A *		
3 V MOTOR=	1/2/3/4	2*		
4 P MOTOR=	4 - 999	__ _ KW		
5 COS PHI M=	40 – 99%	85%		
6 FREQ=	50/60	50Hz		
G3 PROTECTIONS				
1 PHASE SEQUEN=	1/2/3	2*		
2 OV LOAD=	0,5-1,5 I _{SS7}	1 x I		
3 OV/LOAD T=	1-10	5		
4 OVL FAC=	100-500%	100%		
5 MOTOR PTC=	Yes/No	N		
6 UNLOAD=	0-0,8	0.0A		
7 UNLOAD T=	0-99/Off	OFF		
8 SHRPIN=	0,6-1,2/Off	OFF		
9 ASYM I ENB=	Yes/No	YES		
10 UNDER V=	162-450	320V		
11 U/V DELAY=	0-10/Off	5s		
12 OVERVOLT=	254-575	440V		
13 O/V DELAY=	0-10/Off	5s		
14 START LIMIT=	1-10	3		
15 STR/ INT=	0-60/Off	15Min		
G4 ACCELERATION				
1 STR DELAY=	0-600	0s		
2 PULS TORQ=	50-99%	50%		
3 PULS TQ T=	0,1-0,9/Off	OFF		
4 INIT TORQ=	0-100%	35%		
5 INIT TQ T=	0-99	1s		

* See section '11 SCREEN DESCRIPTION'.

SCREENS	RANGE	DEFAULT	RECORD 1	RECORD 2
6 ACEL TIME=	0-180	6s		
7 I LIMIT=	1.5 - 5 x In	2800A		
G5 DECELERATION				
1 FREWEL STP=	Yes/No	YES		
2 DECL TIME=	0-180	12s		
3 DEC MD SEL=	1/2	1*		
4 HAMR FACT=	0-100%	75%		
5 MINI TORQ=	0-80%	1%		
G6 INPUTS				
1 OPER MODE=	1/2/3/4/5	1*		
2 LOCAL RESET=	Yes/No	Y		
3 DINPUT1 SEL=	0-10	4*		
4 DINPUT2 SEL=	0-10	0*		
5 DINPUT3 SEL=	0-10	0*		
6 DINPUT4 SEL=	0-10	0*		
7 DINPUT5 SEL=	0-10	0*		
8 ANI1 FORMAT=	0/1/2	1		
9 AI1 RANGE=	0-100	0-10		
10 AI1 UNITS=	Off/Bar/°C/m	OFF		
11 ANI2 FORMAT=	0/1/2	1		
12 AI2RANGE=	0-100	0-10		
13 AI2 UNITS=	Off /Bar/°C/m	OFF		
G7 OUTPUTS				
1 REL1 SEL ON=	1-21	14*		
2 REL2 SEL ON=	1-21	15*		
3 REL3 SEL ON=	1-21	9*		
4 ANLOG1 SEL=	0-7	0*		
5 AO1 FORMAT=	0/1	0*		
6 AO1 LOW=	0-500	0%		
7 AO1 HIGH=	0-500	100%		
G8 DUAL SETTING				
1 DUALSETING=	Yes/No	NO		
2 PLS TORQ2=	50-99%	50%		
3 PLS TQ T2=	0,1-0,9/Off	OFF		
4 INIT TRQ2=	0-100%/Off	30%		
5 INIT TQ T2=	0-99	1s		
6 ACC TIME2=	0-180	12s		
7 I LIMIT2=	1-5 I _{SS7}	2800A		
8 FREWEL STP2=	Yes/No	N		
9 DEC TIME2=	0-180	12s		
10 DEC MD SEL2=	1/2	1		
11 HAMR FAC2=	0-99	75		
12 MINI TRQ2=	1-99%	1%		
13 PHASE SEQ2=	1/2/3	2s		

* See section '10 SCREEN DESCRIPTION'.

SCREENS	RANGE	DEFAULT	RECORD 1	RECORD 2
14 OV LOAD2=	0,6-1,5 I _{SS7}	800A		
15 OV/LOAD T2=	1-10	5		
16 OVL FAC2=	100-500%	100%		
17 MTR PTC2=	Yes/No	N		
18 UNLOAD2=	0-0,9	0.0A		
19 UNLOAD T2=	0-99/Off	OFF		
20 SHRPIN2=	0,7-1,2/Off	OFF		
21 ASYM I ENB2=	Yes/No	N		
22 I MTR2=	9-1200	30A		
23 V MTR2=	1/2/3/4	2		
24 P MTR2=	0-999	4.0Kw		
25 COS PHI 2=	40-99%	85%		
26 FREQ 2=	50/60	50Hz		
G9 COMPARATORS				
1 COMPR1 SEL=	0-8	1*		
2 COMP1 ON=	0-100%	100%		
3 COMP1 OFF=	0-100%	80%		
4 T COMP1 ON=	0-100	5s		
5 T COMP1 OFF=	0-100	5s		
6 COMPR2 SEL=	0-8	1*		
7 COMP2 ON=	0-100%	100%		
8 COMP2 OFF =	0-100%	80%		
9 T COMP2 ON=	0-100	5s		
10 TCMP2 OFF=	0-100	5s		
11 CMPR3 SEL=	0-8	1*		
12 CMP3 ON=	0-100%	100%		
13 CMP3 OFF=	0-100%	80%		
14 T CMP3 ON=	0-100	5s		
15 TCMP3 OFF=	0-100	5s		
G10 FAULT HISTORY				
1 LAST FAULT		F0		
2 FOURTH FAULT		F0		
3 THIRD FAULT		F0		
4 SECOND FAULT		F0		
5 FIRST FAULT		F0		
6 DELET FAULTS=		N		
G11 STATIST INFO				
1 STARTS1=		00000		
2 STARTS2=		00000		
3 DEL STARTS2=		NO		
4 H1=		00000h:00m		
5 H2 =		00000h:00m		
6 DEL HOURS2=		NO		
7 TOTAL FLT=		00		
8 FAULT2=		0		
9 DEL FAULT2=		NO		
10 KWH =		000000		

SCREENS	RANGE	DEFAULT	RECORD 1	RECORD 2
G12 SLOW SPEED				
1 L/S ACC-DEC =	Yes/No	N		
2 L SPD TORQ =	0-99%	30%		
3 L.S MAX T =	0-99/Off	0s		
4 L.S ACL T=	0-99/ Off	0s		
5 L.S DEC T=	0-99/ Off	0s		
G13 DC BRAKE				
1 DCBRAK SEL=	Yes/No	NO		
2 DC BRAK I=	30-99%	50%		
3 DC BRAKE T=	0-99/ Off	0s		
4 EXTERNAL B=	Yes/No	NO		
G14 SERIAL COMM				
1 COM TIME O=	0-25/ Off	OFF		
2 COM ADRESS=	0-240	0		
3 BAUD COM=	1200/2400/ 4800/9600/ Off	OFF		
4 EVEN PARITY=	Yes/No	NO		
G15 AUTO RESET				
1 AUTO RESET=	Yes/No	NO		
2 ATTEMP NUMBR=	1-5	5		
3 R STR DEL=	5-120	5s		
4 RS COUNT=	1-60	15Min		
5 F1 AUTO RST =	0-20	0		
6 F2 AUTO RST =	0-20	0		
7 F3 AUTO RST =	0-20	0		
8 F4 AUTO RST =	0-20	0		
G16 PUMP CONTROL 1				
1 SET IT =	0-60/INF	000Hrs		
2 I TIME =	0-60/INF	000Hrs		
3 START MODE =	0/1	0		
4 HI PR DEL =	0-60	00s		
5 L PR DEL=	0-3600	0000s		
6 L PR BYP =	1-1800	0000s		
7 FLO BYP =	0-1800	0000s		
8 FLO DEB =	0-60	00s		
9 LO WTR DEL =	0-60	00s		