



Durability
Precision
Reliability
Simplicity
Cost - effectiveness



Inch System Brand

SPC is a registered trade name for Sang-A Pneumatic Co., Ltd. in north America. The SPC brand logo represents products that are specified in the inch system. Both Sang-A and SPC logos are the registered trade marks of Sang-A Pneumatic Co., Ltd.

3 ONE-TOUCH FITTINGS



SILENCERS 21

10 COMPACT
ONE-TOUCH FITTINGS



HAND VALVES 22

13 SPEED CONTROLLERS



AIR GUN 23

14 ROTARY JOINTS



TUBINGS 24

16 STOP FITTINGS



ACE COUPLER 26

17 CHECK VALVES



HP COUPLER 27

18 BALL VALVES



TWO-TOUCH FITTINGS 28

20 MAIN BLOCKS



MEMO 29



Metric System Brand

Sang-A is a registered trade name for Sang-A Pneumatic Co., Ltd. in Europe and Asia. The Sang-A brand logo represents products that are specified in the Metric system.

<http://www.sanga2000.com>
E-mail : sang-a@sanga2000.com

ONE-TOUCH FITTINGS

FEATURES

- Functional One-Touch design facilitates an instant tubing connection.
- Elliptical sleeve configuration is ideal for Pneumatic installations in a confined space.
- Simple manual pressure on the elliptical sleeve results in an instant tubing disconnection.
- Nickel-plated metallic body provides resistance against corrosion and contamination over time.(optional)
- Teflon-coated thread requires no additional sealing.
- Various models are available in both inch and metric sizes.

STRUCTURAL DIAGRAM

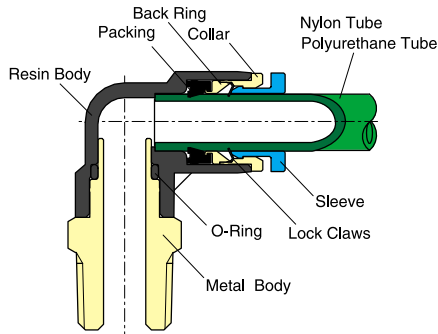

SPECIFICATIONS

Compatible Fluid type	Air(No other gases or liquids)	
Operating Pressure Range	0~150PSI	0~9.9Kgf/cm ² (0~990kPa)
Negative pressure	-29.5 in Hg	-750mmHg(10Torr)
Operating Temperature Range	32~140° F	0~60° C
Recommended Tube Material	Polyurethane and Nylon	

PRODUCTS CODE SYSTEM

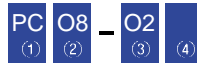

① Model Type

② Tube Outer Dia (∅D)

Code	Metric Size						Inch Size					
	04	06	08	10	12	16	5/32	3/16	1/4	5/16	3/8	1/2
∅Dia	∅4	∅6	∅8	∅10	∅12	∅16	∅5/32	∅3/16	∅1/4	∅5/16	∅3/8	∅1/2

③ Thread Size(T)

※ Metric Thread & R(PT) Thread

Code	Metric Size		Taper Pipe Thread			
	M5	M6	01	02	03	04
Size	M5 × 0.8	M6 × 1.0	R1/8	R1/4	R3/8	R1/2

※ Inch Thread (UNF & NPT)

Code	Unified Fine Thread		American Standard Taper Pipe Thread			
	U10U		N01U	N02U	N03U	N04U
Size	10-32UNF		NPT1/8	NPT1/4	NPT3/8	NPT1/2

④ U : Hexagon flat-to-flat inch specification.(NPT)

PC Male Straight	MODEL [∅D-T]						
	Tube(Metric)-Thread(R)			Tube(Inch)-Thread(R)		Tube(Inch)-Thread(NPT)	
T ∅D	PC 04-M5	PC 08-02	PC 16-03	PC 5/32-01	PC 3/8-01	PC 5/32-U10U	PC 5/16-N01U
	PC 04-M6	PC 08-03	PC 16-04	PC 5/32-02	PC 3/8-02	PC 5/32-N01U	PC 5/16-N02U
	PC 04-01	PC 08-04		PC 5/32-03	PC 3/8-03	PC 5/32-N02U	PC 5/16-N03U
	PC 04-02	PC 10-01		PC 1/4-01	PC 3/8-04	PC 3/16-U10U	PC 3/8-N01U
	PC 04-03	PC 10-02		PC 1/4-02	PC 1/2-02	PC 3/16-N01U	PC 3/8-N02U
	PC 06-M5	PC 10-03		PC 1/4-03	PC 1/2-03	PC 3/16-N02U	PC 3/8-N03U
	PC 06-M6	PC 10-04		PC 5/16-01	PC 1/2-04	PC 3/16-N03U	PC 3/8-N04U
	PC 06-01	PC 12-01		PC 5/16-02		PC 1/4-U10U	PC 1/2-N02U
	PC 06-02	PC 12-02		PC 5/16-03		PC 1/4-N01U	PC 1/2-N03U
	PC 06-03	PC 12-03				PC 1/4-N02U	PC 1/2-N04U
	PC 08-01	PC 12-04				PC 1/4-N03U	

*Hexagonal wrench may be used for a proper tightening.

PL Male Elbow	MODEL [∅D-T]						
	Tube(Metric)-Thread(R)			Tube(Inch)-Thread(R)		Tube(Inch)-Thread(NPT)	
T ∅D	PL 04-M5	PL 08-02	PL 16-03	PL 1/4-01	PL 3/8-01	PL 5/32-U10U	PL 5/16-N01U
	PL 04-M6	PL 08-03	PL 16-04	PL 1/4-02	PL 3/8-02	PL 5/32-N01U	PL 5/16-N02U
	PL 04-01	PL 08-04		PL 1/4-03	PL 3/8-03	PL 5/32-N02U	PL 5/16-N03U
	PL 04-02	PL 10-01		PL 5/16-01	PL 3/8-04	PL 3/16-U10U	PL 3/8-N01U
	PL 04-03	PL 10-02		PL 5/16-02	PL 1/2-02	PL 3/16-N01U	PL 3/8-N02U
	PL 06-M5	PL 10-03		PL 5/16-03	PL 1/2-03	PL 3/16-N02U	PL 3/8-N03U
	PL 06-M6	PL 10-04			PL 1/2-04	PL 3/16-N03U	PL 3/8-N04U
	PL 06-01	PL 12-01				PL 1/4-U10U	PL 1/2-N02U
	PL 06-02	PL 12-02				PL 1/4-N01U	PL 1/2-N03U
	PL 06-03	PL 12-03				PL 1/4-N02U	PL 1/2-N04U
	PL 08-01	PL 12-04				PL 1/4-N03U	

*Rotating body construction after a proper installation.

PT Male Branch Tee	MODEL [∅D-T]						
	Tube(Metric)-Thread(R)			Tube(Inch)-Thread(R)		Tube(Inch)-Thread(NPT)	
T ∅D	PT 04-M5	PT 08-02	PT 16-03	PT 1/4-01	PT 3/8-01	PT 5/32-U10U	PT 5/16-N01U
	PT 04-M6	PT 08-03	PT 16-04	PT 1/4-02	PT 3/8-02	PT 5/32-N01U	PT 5/16-N02U
	PT 04-01	PT 08-04		PT 1/4-03	PT 3/8-03	PT 5/32-N02U	PT 5/16-N03U
	PT 04-02	PT 10-01		PT 5/16-01	PT 3/8-04	PT 3/16-U10U	PT 3/8-N01U
	PT 04-03	PT 10-02		PT 5/16-02	PT 1/2-02	PT 3/16-N01U	PT 3/8-N02U
	PT 06-M5	PT 10-03		PT 5/16-03	PT 1/2-03	PT 3/16-N02U	PT 3/8-N03U
	PT 06-M6	PT 10-04			PT 1/2-04	PT 3/16-N03U	PT 3/8-N04U
	PT 06-01	PT 12-01				PT 1/4-U10U	PT 1/2-N02U
	PT 06-02	PT 12-02				PT 1/4-N01U	PT 1/2-N03U
	PT 06-03	PT 12-03				PT 1/4-N02U	PT 1/2-N04U
	PT 08-01	PT 12-04				PT 1/4-N03U	

*Rotating body construction after a proper installation.

 PST Male Run Tee 	MODEL [∅D-T]					
	Tube(Metric)-Thread(R)		Tube(Inch)-Thread(R)		Tube(Inch)-Thread(NPT)	
	PST 04-M5	PST 08-02	PST 1/4-01	PST 3/8-02	PST 5/32-U10U	PST 5/16-N01U
PST 04-M6	PST 08-03	PST 1/4-02	PST 3/8-03	PST 5/32-N01U	PST 5/16-N02U	
PST 04-01	PST 08-04	PST 1/4-03	PST 3/8-04	PST 5/32-N02U	PST 5/16-N03U	
PST 04-02	PST 10-01	PST 5/16-01	PST 1/2-02	PST 3/16-U10U	PST 3/8-N02U	
PST 04-03	PST 10-02	PST 5/16-02	PST 1/2-03	PST 3/16-N01U	PST 3/8-N03U	
PST 06-M5	PST 10-03	PST 5/16-03	PST 1/2-04	PST 3/16-N02U	PST 3/8-N04U	
PST 06-M6	PST 10-04			PST 3/16-N03U	PST 1/2-N02U	
PST 06-01	PST 12-01			PST 1/4-U10U	PST 1/2-N03U	
PST 06-02	PST 12-02			PST 1/4-N01U	PST 1/2-N04U	
PST 06-03	PST 12-03			PST 1/4-N02U		
PST 08-01	PST 12-04			PST 1/4-N03U		

*Rotating body construction after a proper installation.

 POC Round Male Straight 	MODEL [∅D-T]				
	Tube(Metric)-Thread(R)		Tube(Inch)-Thread(R)	Tube(Inch)-Thread(NPT)	
	POC 04-M5	POC 08-02	POC 1/4-01	POC 5/32-U10U	POC 1/2-N02U
POC 04-M6	POC 08-03	POC 1/4-02	POC 5/32-N01U	POC 1/2-N03U	
POC 04-01	POC 08-04	POC 5/16-01	POC 1/4-U10U	POC 1/2-N04U	
POC 04-02	POC 10-01	POC 5/16-02	POC 1/4-N01U		
POC 04-03	POC 10-02	POC 5/16-03	POC 1/4-N02U		
POC 06-M5	POC 10-03	POC 3/8-02	POC 5/16-N01U		
POC 06-M6	POC 10-04	POC 3/8-03	POC 5/16-N02U		
POC 06-01	POC 12-01	POC 3/8-04	POC 5/16-N03U		
POC 06-02	POC 12-02		POC 3/8-N02U		
POC 06-03	POC 12-03		POC 3/8-N03U		
POC 08-01	POC 12-04		POC 3/8-N04U		

*Hexagonal wrench may be used for a proper tightening.

 PCF Female Straight 	MODEL [∅D-T]				
	Tube(Metric)-Thread(Rc)		Tube(Inch)-Thread(Rc)	Tube(Inch)-Thread(NPT)	
	PCF 04-01	PCF 10-01	PCF 1/4-01	PCF 5/32-N01U	PCF 5/16-N01U
PCF 04-02	PCF 10-02	PCF 1/4-02	PCF 5/32-N02U	PCF 5/16-N02U	
PCF 04-03	PCF 10-03	PCF 5/16-01	PCF 3/16-N01U	PCF 5/16-N03U	
PCF 06-01	PCF 10-04	PCF 5/16-02	PCF 3/16-N02U	PCF 3/8-N02U	
PCF 06-02	PCF 12-02	PCF 3/8-02	PCF 1/4-N01U	PCF 3/8-N03U	
PCF 06-03	PCF 12-03	PCF 3/8-03	PCF 1/4-N02U	PCF 1/2-N02U	
PCF 08-01	PCF 12-04			PCF 1/2-N03U	
PCF 08-02					
PCF 08-03					
PCF 08-04					

 PH Male Banjo 	MODEL [∅D-T]				
	Tube(Metric)-Thread(R)		Tube(Inch)-Thread(R)	Tube(Inch)-Thread(NPT)	
	PH 04-M5	PH 08-01	PH 1/4-01	PH 5/32-U10U	PH 5/16-N01U
PH 04-M6	PH 08-02	PH 1/4-02	PH 5/32-N01U	PH 5/16-N02U	
PH 04-01	PH 08-03	PH 5/16-01	PH 3/16-U10U	PH 5/16-N03U	
PH 06-M5	PH 08-04	PH 5/16-02	PH 3/16-N01U	PH 3/8-N02U	
PH 06-M6	PH 10-02	PH 5/16-03	PH 3/16-N02U	PH 3/8-N03U	
PH 06-01	PH 10-03	PH 3/8-02	PH 3/16-N03U	PH 1/2-N03U	
PH 06-02	PH 10-04	PH 3/8-03	PH 1/4-N01U	PH 1/2-N04U	
PH 06-03	PH 12-03		PH 1/4-N02U		
	PH 12-04				

*Rotating body construction after a proper installation.

 PHF Female Banjo 	MODEL [∅D-T]				
	Tube(Metric)-Thread(R)		Tube(Inch)-Thread(R)	Tube(Inch)-Thread(NPT)	
	PHF 04-M5	PHF 08-01	PHF 1/4-M5	PHF 5/32-U10U	PHF 5/16-N01U
PHF 04-M6	PHF 08-02	PHF 1/4-01	PHF 5/32-N01U	PHF 5/16-N02U	
PHF 04-01	PHF 08-03	PHF 1/4-02	PHF 3/16-U10U	PHF 5/16-N03U	
PHF 06-M5	PHF 10-02	PHF 5/16-01	PHF 3/16-N01U	PHF 3/8-N02U	
PHF 06-M6	PHF 10-03	PHF 5/16-02	PHF 3/16-N02U	PHF 3/8-N03U	
PHF 06-01	PHF 12-03	PHF 5/16-03	PHF 1/4-U10U	PHF 1/2-N03U	
PHF 06-02	PHF 12-04	PHF 3/8-02	PHF 1/4-N01U	PHF 1/2-N04U	
		PHF 3/8-03	PHF 1/4-N02U		

*Rotating body construction after a proper installation.

 PWT Male Y 	MODEL [∅D-T]					
	Tube(Metric)-Thread(R)		Tube(Inch)-Thread(R)		Tube(Inch)-Thread(NPT)	
	PWT 04-M5	PWT 08-02	PWT 1/4-01	PWT 3/8-02	PWT 5/32-U10U	PWT 5/16-N01U
PWT 04-M6	PWT 08-03	PWT 1/4-02	PWT 3/8-03	PWT 5/32-N01U	PWT 5/16-N02U	
PWT 04-01	PWT 08-04	PWT 1/4-03	PWT 3/8-04	PWT 5/32-N02U	PWT 5/16-N03U	
PWT 04-02	PWT 10-01	PWT 5/16-01	PWT 1/2-02	PWT 3/16-U10U	PWT 3/8-N02U	
PWT 04-03	PWT 10-02	PWT 5/16-02	PWT 1/2-03	PWT 3/16-N01U	PWT 3/8-N03U	
PWT 06-M5	PWT 10-03	PWT 5/16-03	PWT 1/2-04	PWT 3/16-N02U	PWT 3/8-N04U	
PWT 06-M6	PWT 10-04			PWT 3/16-N03U	PWT 1/2-N02U	
PWT 06-01	PWT 12-01			PWT 1/4-U10U	PWT 1/2-N03U	
PWT 06-02	PWT 12-02			PWT 1/4-N01U	PWT 1/2-N04U	
PWT 06-03	PWT 12-03			PWT 1/4-N02U		
PWT 08-01	PWT 12-04			PWT 1/4-N03U		

*Rotating body construction after a proper installation.



PHT Double Universal Elbow	MODEL [∅D-T]	
	Tube(Metric)-Thread(R)	
	PHT 04-01(2)	PHT 10-03(2)
	PHT 04-02(2)	PHT 10-04(2)
	PHT 04-03(2)	PHT 12-02(2)
	PHT 06-01(2)	PHT 12-03(2)
	PHT 06-02(2)	PHT 12-04(2)
	PHT 06-03(2)	
	PHT 08-01(2)	
	PHT 08-02(2)	
	PHT 08-03(2)	
	PHT 08-04(2)	
	PHT 10-02(2)	

*Rotating body construction after a proper installation.

PMF Bulkhead Female Straight	MODEL [∅D-T]			
	Tube(Metric)-Thread(R)		Tube(Inch)-Thread(NPT)	
	PMF 04-01	PMF 10-01	PMF 5/32-N01U	PMF 3/8-N02U
	PMF 04-02	PMF 10-02	PMF 3/16-N01U	PMF 3/8-N03U
	PMF 04-03	PMF 10-03	PMF 3/16-N02U	PMF 1/2-N03U
	PMF 06-01	PMF 10-04	PMF 1/4-N01U	PMF 1/2-N04U
	PMF 06-02	PMF 12-01	PMF 1/4-N02U	
	PMF 06-03	PMF 12-02	PMF 5/16-N01U	
	PMF 08-01	PMF 12-03	PMF 5/16-N02U	
	PMF 08-02	PMF 12-04	PMF 5/16-N03U	
	PMF 08-03			
	PMF 08-04			

PHT Triple Universal Elbow	MODEL [∅D-T]	
	Tube(Metric)-Thread(R)	
	PHT 04-01(3)	PHT 10-03(3)
	PHT 04-02(3)	PHT 10-04(3)
	PHT 04-03(3)	PHT 12-02(3)
	PHT 06-01(3)	PHT 12-03(3)
	PHT 06-02(3)	PHT 12-04(3)
	PHT 06-03(3)	
	PHT 08-01(3)	
	PHT 08-02(3)	
	PHT 08-03(3)	
	PHT 08-04(3)	
	PHT 10-02(3)	

*Rotating body construction after a proper installation.

PCJ Plug-In Male	MODEL [∅D-T]			
	Tube(Metric)-Thread(R)		Tube(Inch)-Thread(NPT)	
	PCJ 04-M5	PCJ 10-03	PCJ 5/32-U10U	PCJ 5/16-N03U
	PCJ 04-01	PCJ 10-04	PCJ 5/32-N01U	PCJ 3/8-N02U
	PCJ 04-02	PCJ 12-02	PCJ 5/32-N02U	PCJ 3/8-N03U
	PCJ 06-M5	PCJ 12-03	PCJ 3/16-U10U	PCJ 3/8-N04U
	PCJ 06-01	PCJ 12-04	PCJ 3/16-N01U	PCJ 1/2-N02U
	PCJ 06-02	PCJ 16-03	PCJ 3/16-N02U	PCJ 1/2-N03U
	PCJ 06-03	PCJ 16-04	PCJ 1/4-N01U	PCJ 1/2-N04U
	PCJ 08-01		PCJ 1/4-N02U	
	PCJ 08-02		PCJ 1/4-N03U	
	PCJ 08-03		PCJ 5/16-N01U	
	PCJ 10-02		PCJ 5/16-N02U	

PAT Double Branch A	MODEL [∅D-T]	
	Tube(Metric)-Thread(R)	
	PAT 04-01(2)	PAT 10-03(2)
	PAT 04-02(2)	PAT 10-04(2)
	PAT 04-03(2)	PAT 12-02(2)
	PAT 06-01(2)	PAT 12-03(2)
	PAT 06-02(2)	PAT 12-04(2)
	PAT 06-03(2)	
	PAT 08-01(2)	
	PAT 08-02(2)	
	PAT 08-03(2)	
	PAT 08-04(2)	
	PAT 10-02(2)	

*Rotating body construction after a proper installation.

PLF Female Elbow	MODEL [∅D-T]			
	Tube(Metric)-Thread(Rc)		Tube(Inch)-Thread(NPT)	
	PLF 04-M5	PLF 10-02	PLF 5/32-N01U	PLF 3/8-N02U
	PLF 04-M6	PLF 10-03	PLF 5/32-N02U	PLF 3/8-N03U
	PLF 04-01	PLF 10-04	PLF 3/16-N01U	PLF 3/8-N04U
	PLF 06-M5		PLF 3/16-N02U	
	PLF 06-M6		PLF 3/16-N03U	
	PLF 06-01		PLF 1/4-N01U	
	PLF 06-02		PLF 1/4-N02U	
	PLF 06-03		PLF 5/16-N01U	
	PLF 08-01		PLF 5/16-N02U	
	PLF 08-02		PLF 5/16-N03U	
	PLF 08-03			

*Rotating body construction after a proper installation.

PAT Triple Branch A	MODEL [∅D-T]	
	Tube(Metric)-Thread(R)	
	PAT 04-01(3)	PAT 10-03(3)
	PAT 04-02(3)	PAT 10-04(3)
	PAT 04-03(3)	PAT 12-02(3)
	PAT 06-01(3)	PAT 12-03(3)
	PAT 06-02(3)	PAT 12-04(3)
	PAT 06-03(3)	
	PAT 08-01(3)	
	PAT 08-02(3)	
	PAT 08-03(3)	
	PAT 08-04(3)	
	PAT 10-02(3)	

*Rotating body construction after a proper installation.

PTF Female Branch Tee	MODEL [∅D-T]			
	Tube(Metric)-Thread(Rc)		Tube(Inch)-Thread(NPT)	
	PTF 04-M5	PTF 10-02	PTF 5/32-U01U	PTF 3/8-N02U
	PTF 04-M6	PTF 10-03	PTF 5/32-N02U	PTF 3/8-N03U
	PTF 04-01	PTF 10-04	PTF 3/16-U01U	PTF 3/8-N04U
	PTF 06-M5		PTF 3/16-N02U	
	PTF 06-M6		PTF 3/16-N03U	
	PTF 06-01		PTF 1/4-N01U	
	PTF 06-02		PTF 1/4-N02U	
	PTF 06-03		PTF 1/4-N03U	
	PTF 08-01		PTF 5/16-N01U	
	PTF 08-02		PTF 5/16-N02U	
	PTF 08-03		PTF 5/16-N03U	



POL Hex. Holed Banjo	MODEL [∅D-T]			
	Tube(Metric)-Thread(R)		Tube(Inch)-Thread(NPT)	
	POL 04-M5	POL 08-04	POL 5/32-U10U	POL 5/16-N02U
	POL 04-M6	POL 10-02	POL 5/32-N01U	POL 5/16-N03U
	POL 04-01	POL 10-03	POL 3/16-U10U	POL 3/8-N02U
	POL 06-M5	POL 10-04	POL 3/16-N01U	POL 3/8-N03U
	POL 06-M6	POL 12-02	POL 3/16-N02U	POL 1/2-N03U
	POL 06-01	POL 12-03	POL 3/16-N03U	POL 1/2-N04U
	POL 06-02	POL 12-04	POL 1/4-U10U	
	POL 06-03		POL 1/4-N01U	
	POL 08-01		POL 1/4-N02U	
	POL 08-02		POL 1/4-N03U	
	POL 08-03		POL 5/16-N01U	

*Rotating body construction after a proper installation.

PLL Extended Male Elbow	MODEL [∅D-T]				
	Tube(Metric)-Thread(R)		Tube(Inch)-Thread(R)	Tube(Inch)-Thread(NPT)	
	PLL 04-M5	PLL 08-02	PLL 1/4-01	PLL 5/32-U10U	PLL 5/16-N01U
	PLL 04-M6	PLL 08-03	PLL 1/4-02	PLL 5/32-N01U	PLL 5/16-N02U
	PLL 04-01	PLL 08-04	PLL 5/16-01	PLL 3/16-N01U	PLL 5/16-N03U
	PLL 04-02	PLL 10-01	PLL 5/16-02	PLL 3/16-N02U	PLL 3/8-N02U
	PLL 04-03	PLL 10-02	PLL 3/8-02	PLL 3/16-N03U	PLL 3/8-N03U
	PLL 06-M5	PLL 10-03	PLL 3/8-03	PLL 1/4-N01U	PLL 3/8-N04U
	PLL 06-M6	PLL 10-04		PLL 1/4-N02U	PLL 1/2-N02U
	PLL 06-01	PLL 12-01		PLL 1/4-N03U	PLL 1/2-N03U
	PLL 06-02	PLL 12-02			PLL 1/2-N04U
	PLL 06-03	PLL 12-03			
	PLL 08-01	PLL 12-04			

*Hexagonal wrench may be used for a proper tightening.

	MODEL [\varnothing D]	
	Tube(Metric)	Tube(Inch)
PUC 04	PUC 5/32	
PUC 06	PUC 3/16	
PUC 08	PUC 1/4	
PUC 10	PUC 5/16	
PUC 12	PUC 3/8	
PUC 16	PUC 1/2	
	PUC 1/2-1/4	

	MODEL [\varnothing D]	
	Tube(Metric)	Tube(Inch)
CAS 04	CAS 5/32	
CAS 06	CAS 3/16	
CAS 08	CAS 1/4	
CAS 10	CAS 5/16	
CAS 12	CAS 3/8	
CAS 16	CAS 1/2	

	MODEL [\varnothing D]	
	Tube(Metric)	Tube(Inch)
PUL 04	PUL 5/32	
PUL 06	PUL 3/16	
PUL 08	PUL 1/4	
PUL 10	PUL 5/16	
PUL 12	PUL 3/8	
PUL 16	PUL 1/2	

	MODEL [\varnothing D]	
	Tube(Metric)	Tube(Inch)
PMM 04	PMM 5/32	
PMM 06	PMM 3/16	
PMM 08	PMM 1/4	
PMM 10	PMM 5/16	
PMM 12	PMM 3/8	
	PMM 1/2	

	MODEL [\varnothing D]	
	Tube(Metric)	Tube(Inch)
PUT 04	PUT 5/32	
PUT 06	PUT 3/16	
PUT 08	PUT 1/4	
PUT 10	PUT 5/16	
PUT 12	PUT 3/8	
PUT 16	PUT 1/2	
	PUT 1/2-1/4	

	MODEL [\varnothing D]
	Tube(Metric)
PPM 04	
PPM 06	
PPM 08	
PPM 10	
PPM 12	

	MODEL [\varnothing D]	
	Tube(Metric)	Tube(Inch)
PY 04	PY 5/32	
PY 06	PY 3/16	
PY 08	PY 1/4	
PY 10	PY 5/16	
PY 12	PY 3/8	
	PY 1/2	

	MODEL [\varnothing D]	
	Tube(Metric)	Tube(Inch)
PPF 04	PPF 5/32	
PPF 06	PPF 3/16	
PPF 08	PPF 1/4	
PPF 10	PPF 5/16	
PPF 12	PPF 3/8	
	PPF 1/2	

	MODEL [\varnothing D]
	Tube(Metric)
PCP 04	
PCP 06	
PCP 08	
PCP 10	
PCP 12	
PCP 16	

	MODEL [\varnothing D]	
	Tube(Metric)	Tube(Inch)
PZA 04	PZA 5/32	
PZA 06	PZA 3/16	
PZA 08	PZA 1/4	
PZA 10	PZA 5/16	
PZA 12	PZA 3/8	
	PZA 1/2	

	MODEL [\varnothing D1- \varnothing D2]		
	Tube(Metric)	Tube(Metric)-Tube(Inch)	Tube(Inch)
PGJ 06-04	PGJ 08-1/4	PGJ 1/4-5/32	
PGJ 08-04	PGJ 10-1/4	PGJ 5/16-5/32	
PGJ 08-06	PGJ 10-5/16	PGJ 5/16-1/4	
PGJ 10-06	PGJ 12-1/4	PGJ 3/8-1/4	
PGJ 10-08	PGJ 12-5/16	PGJ 3/8-5/16	
PGJ 12-06	PGJ 12-3/8	PGJ 1/2-1/4	
PGJ 12-08			
PGJ 12-10			



PG Reducer	MODEL [$\varnothing D_1$ - $\varnothing D_2$]	
	Tube(Metric)	Tube(Inch)
	PG 06-04	PG 3/16-5/32
	PG 08-06	PG 1/4-3/16
	PG 10-08	PG 1/4-5/32
	PG 12-10	PG 5/16-1/4
	PG 16-12	PG 3/8-5/16
		PG 1/2-3/8

PIJ Tube Splicer	MODEL [$\varnothing D$]	
	Tube(Metric)	Tube(Inch)
	PIJ 04	PIJ 5/32
	PIJ 06	PIJ 3/16
	PIJ 08	PIJ 1/4
	PIJ 10	PIJ 5/16
	PIJ 12	PIJ 3/8
	PIJ 16	PIJ 1/2

PA Dual Male Banjo	MODEL [$\varnothing D$ -T]	
	Tube(Metric)-Thread(R)	Tube(Inch)-Thread(NPT)
	PA 04-M5	PA 5/32-U10U
	PA 06-01	PA 3/16-N01U
	PA 08-02	PA 1/4-N01U
	PA 10-03	PA 5/16-N02U
	PA 12-04	PA 3/8-N03U
		PA 1/2-N04U

PIG Reducer Tube Splicer	MODEL [$\varnothing D_1$ - $\varnothing D_2$]	
	Tube(Metric)	Tube(Inch)
	PIG 06-04	PIG 3/16-5/32
	PIG 08-06	PIG 1/4-5/32
	PIG 10-08	PIG 1/4-3/16
	PIG 12-10	PIG 5/16-1/4
	PIG 16-12	PIG 3/8-5/16
		PIG 1/2-3/8

*Rotating body construction after a proper installation.

PAF Dual Female Banjo	MODEL [$\varnothing D$ -T]	
	Tube(Metric)-Thread(R)	Tube(Inch)-Thread(NPT)
	PAF 04-M5	PAF 5/32-U10U
	PAF 06-01	PAF 3/16-N01U
	PAF 08-02	PAF 1/4-N01U
	PAF 10-03	PAF 5/16-N02U
	PAF 12-04	PAF 3/8-N03U
		PAF 1/2-N04U

PP Plug	MODEL [$\varnothing D$]	
	Tube(Metric)	Tube(Inch)
	PP 04	PP 5/32
	PP 06	PP 3/16
	PP 08	PP 1/4
	PP 10	PP 5/16
	PP 12	PP 3/8
	PP 16	PP 1/2

*Rotating body construction after a proper installation.

PLJ Plug-In Elbow	MODEL [$\varnothing D$]	
	Tube(Metric)	Tube(Inch)
	PLJ 04	PLJ 5/32
	PLJ 06	PLJ 3/16
	PLJ 08	PLJ 1/4
	PLJ 10	PLJ 5/16
	PLJ 12	PLJ 3/8
	PLJ 16	PLJ 1/2

PYJ Plug-In Y	MODEL [$\varnothing D$]	
	Tube(Metric)	Tube(Inch)
	PYJ 04	PYJ 5/32
	PYJ 06	PYJ 3/16
	PYJ 08	PYJ 1/4
	PYJ 10	PYJ 5/16
	PYJ 12	PYJ 3/8
		PYJ 1/2

PLLJ Plug-In Extended Elbow	MODEL [$\varnothing D$]	
	Tube(Metric)	Tube(Inch)
	PLLJ 04	PLLJ 5/32
	PLLJ 06	PLLJ 3/16
	PLLJ 08	PLLJ 1/4
	PLLJ 10	PLLJ 5/16
	PLLJ 12	PLLJ 3/8
	PLLJ 16	PLLJ 1/2

PWJ Plug-In Reducer Y	MODEL [$\varnothing D_1$ - $\varnothing D_2$]	
	Tube(Metric)	Tube(Inch)
	PWJ 06-04	PWJ 1/4-5/32
	PWJ 08-06	PWJ 5/16-1/4
	PWJ 10-08	PWJ 3/8-5/16
	PWJ 12-10	

PLGJ Plug-In Reducer Elbow	MODEL [$\varnothing D_1$ - $\varnothing D_2$]	
	Tube(Metric)	Tube(Inch)
	PLGJ 06-04	PLGJ 3/16-5/32
	PLGJ 08-06	PLGJ 1/4-3/16
	PLGJ 10-08	PLGJ 1/4-5/32
	PLGJ 12-10	PLGJ 5/16-1/4
		PLGJ 3/8-5/16
		PLGJ 1/2-3/8

PW Reducer Y	MODEL [$\varnothing D_1$ - $\varnothing D_2$]	
	Tube(Metric)	Tube(Inch)
	PW 06-04	PW 3/16-5/32
	PW 08-06	PW 1/4-3/16
	PW 10-08	PW 1/4-5/32
	PW 12-10	PW 5/16-1/4
		PW 3/8-5/16
		PW 1/2-3/8

<p>PVG Reducer Double Y Union</p> <p>ØD₁</p> <p>ØD₂</p>	MODEL [ØD ₁ -ØD ₂]	
	Tube(Metric)	Tube(Inch)
	PVG 06-04	
	PVG 08-06	

<p>PXJ Reducer Double Y</p> <p>ØD₁</p> <p>ØD₂</p>	MODEL [ØD ₁ -ØD ₂]	
	Tube(Metric)	Tube(Inch)
	PXJ 06-04	
	PXJ 08-06	

<p>PXT Male Double Y</p> <p>T</p> <p>ØD</p>	MODEL [ØD-T]	
	Tube(Metric)-Thread(R)	Tube(Inch)-Thread(NPT)
	PXT 04-01	
	PXT 04-02	
PXT 06-01		

*Rotating body construction after a proper installation.

<p>PKG Reducer Triple Branch Union</p> <p>ØD₂</p> <p>ØD₁</p>	MODEL [ØD ₁ -ØD ₂]	
	Tube(Metric)	Tube(Inch)
	PKG 06-04	PKG 3/16-5/32
	PKG 08-04	PKG 5/16-5/32
	PKG 08-06	PKG 5/16-3/16
	PKG 10-06	PKG 5/16-1/4
	PKG 10-08	PKG 3/8-1/4
	PKG 3/8-5/16	

<p>PKJ Plug-In Reducer Triple Branch</p> <p>ØD₁</p> <p>ØD₂</p> <p>ØD₁</p>	MODEL [ØD ₁ -ØD ₂]	
	Tube(Metric)	Tube(Inch)
	PKJ 06-04	PKJ 3/16-5/32
	PKJ 08-04	PKJ 5/16-5/32
	PKJ 08-06	PKJ 5/16-3/16
	PKJ 10-08	PKJ 5/16-1/4
		PKJ 3/8-5/16
	PKJ 1/4-5/32	

<p>PKD Male Reducer Triple Branch</p> <p>T</p> <p>ØD₂</p> <p>ØD₁</p>	MODEL [ØD ₁ -ØD ₂ -T]	
	Tube(Metric)-Thread(R)	Tube(Inch)-Thread(NPT)
	PKD 06-04-01	PKD 3/16-5/32-N01U
	PKD 08-04-02	PKD 5/16-5/32-N02U
	PKD 08-06-02	PKD 5/16-3/16-N02U
PKD 10-08-03	PKD 5/16-1/4-N02U	
	PKD 3/8-5/16-N03U	

<p>PC-G Male Straight</p> <p>ØD</p> <p>T</p>	MODEL [ØD-T]	
	Tube(Metric)-Thread(G)	
	PC 04-G01	PC 10-G03
	PC 04-G02	PC 10-G04
	PC 04-G03	PC 12-G02
	PC 06-G01	PC 12-G03
	PC 06-G02	PC 12-G04
	PC 06-G03	PC 16-G03
	PC 08-G01	PC 16-G04
	PC 08-G02	
	PC 08-G03	
PC 10-G01		
PC 10-G02		

<p>PL-G Male Elbow</p> <p>T</p> <p>ØD</p>	MODEL [ØD-T]	
	Tube(Metric)-Thread(G)	
	PL 04-G01	PL 10-G03
	PL 04-G02	PL 10-G04
	PL 04-G03	PL 12-G02
	PL 06-G01	PL 12-G03
	PL 06-G02	PL 12-G04
	PL 06-G03	PL 16-G03
	PL 08-G01	PL 16-G04
	PL 08-G02	
	PL 08-G03	
PL 10-G01		
PL 10-G02		

<p>PT-G Male Branch Tee</p> <p>ØD</p> <p>T</p> <p>ØD</p>	MODEL [ØD-T]	
	Tube(Metric)-Thread(G)	
	PT 04-G01	PT 10-G03
	PT 04-G02	PT 10-G04
	PT 04-G03	PT 12-G02
	PT 06-G01	PT 12-G03
	PT 06-G02	PT 12-G04
	PT 06-G03	PT 16-G03
	PT 08-G01	PT 16-G04
	PT 08-G02	
	PT 08-G03	
PT 10-G01		
PT 10-G02		

<p>PST-G Male Run Tee</p> <p>ØD</p> <p>T</p>	MODEL [ØD-T]	
	Tube(Metric)-Thread(G)	
	PST 04-G01	PST 10-G03
	PST 04-G02	PST 10-G04
	PST 04-G03	PST 12-G02
	PST 06-G01	PST 12-G03
	PST 06-G02	PST 12-G04
	PST 06-G03	
	PST 08-G01	
	PST 08-G02	
	PST 08-G03	
PST 10-G01		
PST 10-G02		

<p>PWT-G Male Y</p> <p>ØD</p> <p>T</p>	MODEL [ØD-T]	
	Tube(Metric)-Thread(G)	
	PWT 04-G01	PWT 10-G04
	PWT 04-G02	PWT 12-G02
	PWT 04-G03	PWT 12-G03
	PWT 06-G01	PWT 12-G04
	PWT 06-G02	
	PWT 06-G03	
	PWT 08-G01	
	PWT 08-G02	
	PWT 08-G03	
PWT 10-G02		
PWT 10-G03		

<p>PLL-G Extended Male Elbow</p> <p>T</p> <p>ØD</p>	MODEL [ØD-T]	
	Tube(Metric)-Thread(G)	
	PLL 04-G01	PLL 10-G03
	PLL 04-G02	PLL 10-G04
	PLL 04-G03	PLL 12-G02
	PLL 06-G01	PLL 12-G03
	PLL 06-G02	PLL 12-G04
	PLL 06-G03	
	PLL 08-G01	
	PLL 08-G02	
	PLL 08-G03	
PLL 10-G01		
PLL 10-G02		

PHT-G
Double Universal Elbow



MODEL [\varnothing D-T]
Tube(Metric)-Thread(G)

PHT 04-G01(2)	PHT 10-G03(2)
PHT 04-G02(2)	PHT 10-G04(2)
PHT 04-G03(2)	PHT 12-G02(2)
PHT 06-G01(2)	PHT 12-G03(2)
PHT 06-G02(2)	PHT 12-G04(2)
PHT 06-G03(2)	
PHT 08-G01(2)	
PHT 08-G02(2)	
PHT 08-G03(2)	
PHT 08-G04(2)	
PHT 10-G02(2)	

\varnothing D T

PGL
Single Universal Elbow



MODEL [\varnothing D-T]
Tube(Metric)-Thread(G)

PGL 04-G01(1)	
PGL 06-G01(1)	
PGL 06-G02(1)	
PGL 08-G01(1)	
PGL 08-G02(1)	
PGL 08-G03(1)	
PGL 10-G01(1)	
PGL 10-G02(1)	
PGL 12-G03(1)	
PGL 12-G04(1)	

\varnothing D T

PGB



MODEL [T]
Thread(G)

PGB G01(1)
PGB G02(1)
PGB G03(1)
PGB G04(1)

PHT-G
Triple Universal Elbow



MODEL [\varnothing D-T]
Tube(Metric)-Thread(G)

PHT 04-G01(3)	PHT 10-G03(3)
PHT 04-G02(3)	PHT 10-G04(3)
PHT 04-G03(3)	PHT 12-G02(3)
PHT 06-G01(3)	PHT 12-G03(3)
PHT 06-G02(3)	PHT 12-G04(3)
PHT 06-G03(3)	
PHT 08-G01(3)	
PHT 08-G02(3)	
PHT 08-G03(3)	
PHT 08-G04(3)	
PHT 10-G02(3)	

\varnothing D T

PGL
Double Universal Elbow



MODEL [\varnothing D-T]
Tube(Metric)-Thread(G)

PGL 04-G01(2)	
PGL 06-G01(2)	
PGL 06-G02(2)	
PGL 08-G01(2)	
PGL 08-G02(2)	
PGL 08-G03(2)	
PGL 10-G01(2)	
PGL 10-G02(2)	
PGL 12-G03(2)	
PGL 12-G04(2)	

\varnothing D T

PGB



MODEL [T]
Thread(G)

PGB G01(2)
PGB G02(2)
PGB G03(2)
PGB G04(2)

PAT-G
Double Branch A



MODEL [\varnothing D-T]
Tube(Metric)-Thread(G)

PAT 04-G01(2)	PAT 10-G03(2)
PAT 04-G02(2)	PAT 10-G04(2)
PAT 04-G03(2)	PAT 12-G02(2)
PAT 06-G01(2)	PAT 12-G03(2)
PAT 06-G02(2)	PAT 12-G04(2)
PAT 06-G03(2)	
PAT 08-G01(2)	
PAT 08-G02(2)	
PAT 08-G03(2)	
PAT 08-G04(2)	
PAT 10-G02(2)	

\varnothing D T

PGL
Triple Universal Elbow



MODEL [\varnothing D-T]
Tube(Metric)-Thread(G)

PGL 04-G01(3)	
PGL 06-G01(3)	
PGL 06-G02(3)	
PGL 08-G01(3)	
PGL 08-G02(3)	
PGL 08-G03(3)	
PGL 10-G01(3)	
PGL 10-G02(3)	
PGL 12-G03(3)	
PGL 12-G04(3)	

\varnothing D T

PGB



MODEL [T]
Thread(G)

PGB G01(3)
PGB G02(3)
PGB G03(3)
PGB G04(3)

PAT-G
Triple Branch A



MODEL [\varnothing D-T]
Tube(Metric)-Thread(G)

PAT 04-G01(3)	PAT 10-G03(3)
PAT 04-G02(3)	PAT 10-G04(3)
PAT 04-G03(3)	PAT 12-G02(3)
PAT 06-G01(3)	PAT 12-G03(3)
PAT 06-G02(3)	PAT 12-G04(3)
PAT 06-G03(3)	
PAT 08-G01(3)	
PAT 08-G02(3)	
PAT 08-G03(3)	
PAT 08-G04(3)	
PAT 10-G02(3)	

\varnothing D T

PGT
Single Universal Tee



MODEL [\varnothing D-T]
Tube(Metric)-Thread(G)

PGT 04-G01(1)	
PGT 06-G01(1)	
PGT 06-G02(1)	
PGT 08-G01(1)	
PGT 08-G02(1)	
PGT 08-G03(1)	
PGT 10-G02(1)	
PGT 10-G03(1)	
PGT 12-G03(1)	
PGT 12-G04(1)	

\varnothing D T

PGL



MODEL [\varnothing D-T]
Tube(Metric)-Thread(G)

PGL 04-G01P
PGL 06-G01P
PGL 06-G02P
PGL 08-G01P
PGL 08-G02P
PGL 08-G03P
PGL 10-G02P
PGL 10-G03P
PGL 12-G03P
PGL 12-G04P

\varnothing D

PKD-G
Male Reducer Triple Branch



MODEL [\varnothing D1- \varnothing D2-T]
Tube(Metric)-Thread(G)

PKD 06-04-G01	
PKD 08-04-G02	
PKD 08-06-G02	
PKD 10-08-G03	

\varnothing D₁ T
 \varnothing D₂

PGT
Double Universal Tee



MODEL [\varnothing D-T]
Tube(Metric)-Thread(G)

PGT 04-G01(2)	
PGT 06-G01(2)	
PGT 06-G02(2)	
PGT 08-G01(2)	
PGT 08-G02(2)	
PGT 08-G03(2)	
PGT 10-G02(2)	
PGT 10-G03(2)	
PGT 12-G03(2)	
PGT 12-G04(2)	

\varnothing D T

PGT



MODEL [\varnothing D-T]
Tube(Metric)-Thread(G)

PGT 04-G01P
PGT 06-G01P
PGT 06-G02P
PGT 08-G01P
PGT 08-G02P
PGT 08-G03P
PGT 10-G02P
PGT 10-G03P
PGT 12-G03P
PGT 12-G04P

\varnothing D

PXT-G
Male Double Y



MODEL [\varnothing D-T]
Tube(Metric)-Thread(G)

PXT 04-G01	
PXT 04-G02	
PXT 06-G01	
PXT 06-G02	

\varnothing D T

PGT
Triple Universal Tee



MODEL [\varnothing D-T]
Tube(Metric)-Thread(G)

PGT 04-G01(3)	
PGT 06-G01(3)	
PGT 06-G02(3)	
PGT 08-G01(3)	
PGT 08-G02(3)	
PGT 08-G03(3)	
PGT 10-G02(3)	
PGT 10-G03(3)	
PGT 12-G03(3)	
PGT 12-G04(3)	

\varnothing D T

PGO



MODEL [T]
Thread(G)

PGO G01
PGO G02
PGO G03
PGO G04

COMPACT ONE-TOUCH FITTINGS

FEATURES

- The smallest pneumatic fittings in the world. In fact, the volume is 40% less and the outside diameter is 20% less in comparison to those of the standard type.
- Compact One-Touch Fittings are specially designed for pneumatic installations in equipment that are small and compact in size.

STRUCTURAL DIAGRAM

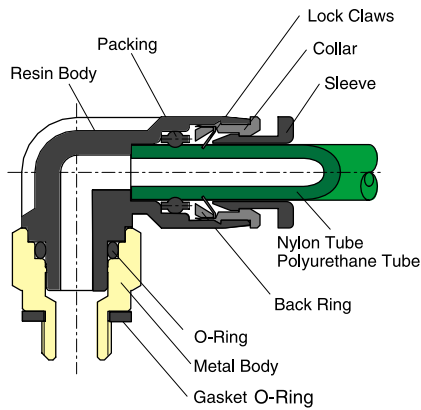

SPECIFICATIONS

Compatible Fluid type	Air(No other gases or liquids)	
Operating Pressure Range	0~150PSI	0~9.9Kgf/cm ² (0~990kPa)
Negative pressure	-29.5 in Hg	-750mmHg(10Torr)
Operating Temperature Range	32~140 ° F	0~60 ° C
Recommended Tube Material	Polyurethane and Nylon	

PRODUCTS CODE SYSTEM

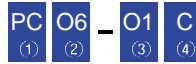

① Model Type

② Tube Dia (∅D)

	Metric Size			Inch Size		
Code	03	04	06	1/8	5/32	1/4
Dia	∅3	∅4	∅6	∅1/8	∅5/32	∅1/4

③ Thread Size(T)

*Metric Thread & R(PT) Thread

	Metric Size			
Code	M3	M5	M6	O1
Size	M3×0.5	M5×0.8	M6×1.0	R1/8

*Inch Thread (UNF & NPT)

	Unified Fine Thread	American Standard Taper Pipe Thread	
Code	U10U	N00U	N01U
Size	10-32UNF	NPT1/16	NPT1/8

④ C=COMPACT

PC-C Male Straight	MODEL (∅D-T)		
	Tube(Metric)-Thread(R)	Tube(Inch)-Thread(R)	Tube(Inch)-Thread(NPT)
	PC 03-M3C	PC 1/8-M3C	PC 1/8-U10UC
	PC 03-M5C	PC 1/8-M5C	PC 1/8-N00UC
	PC 03-M6C	PC 1/8-M6C	PC 1/8-N01UC
	PC 04-M3C	PC 5/32-M3C	PC 5/32-U10UC
	PC 04-M5C	PC 5/32-M5C	PC 5/32-N00UC
	PC 04-M6C	PC 5/32-M6C	PC 5/32-N01UC
	PC 04-01C	PC 5/32-01C	PC 1/4-U10UC
	PC 06-M5C	PC 1/4-M5C	PC 1/4-N00UC
	PC 06-M6C	PC 1/4-M6C	PC 1/4-N01UC
	PC 06-01C	PC 1/4-01C	

PL-C Male Elbow	MODEL (∅D-T)		
	Tube(Metric)-Thread(R)	Tube(Inch)-Thread(R)	Tube(Inch)-Thread(NPT)
	PL 03-M3C	PL 1/8-M3C	PL 1/8-U10UC
	PL 03-M5C	PL 1/8-M5C	PL 1/8-N00UC
	PL 03-M6C	PL 1/8-M6C	PL 1/8-N01UC
	PL 04-M3C	PL 5/32-M3C	PL 5/32-U10UC
	PL 04-M5C	PL 5/32-M5C	PL 5/32-N00UC
	PL 04-M6C	PL 5/32-M6C	PL 5/32-N01UC
	PL 04-01C	PL 5/32-01C	PL 1/4-U10UC
	PL 06-M5C	PL 1/4-M5C	PL 1/4-N00UC
	PL 06-M6C	PL 1/4-M6C	PL 1/4-N01UC
	PL 06-01C	PL 1/4-01C	

PT-C Male Branch Tee	MODEL (∅D-T)		
	Tube(Metric)-Thread(R)	Tube(Inch)-Thread(R)	Tube(Inch)-Thread(NPT)
	PT 03-M3C	PT 1/8-M3C	PT 1/8-U10UC
	PT 03-M5C	PT 1/8-M5C	PT 1/8-N00UC
	PT 03-M6C	PT 1/8-M6C	PT 1/8-N01UC
	PT 04-M3C	PT 5/32-M3C	PT 5/32-U10UC
	PT 04-M5C	PT 5/32-M5C	PT 5/32-N00UC
	PT 04-M6C	PT 5/32-M6C	PT 5/32-N01UC
	PT 04-01C	PT 5/32-01C	PT 1/4-U10UC
	PT 06-M5C	PT 1/4-M5C	PT 1/4-N00UC
	PT 06-M6C	PT 1/4-M6C	PT 1/4-N01UC
	PT 06-01C	PT 1/4-01C	



	MODEL [$\varnothing D$]	
	Tube(Metric)	Tube(Inch)
	PUC 03C	PUC 1/8C
	PUC 04C	PUC 5/32C
PUC 06C	PUC 1/4C	

	MODEL [$\varnothing D-T$]		
	Tube(Metric)-Thread(R)	Tube(Inch)-Thread(R)	Tube(Inch)-Thread(NPT)
	POC 03-M3C	POC 1/8-M3C	POC 1/8-U10UC
	POC 03-M5C	POC 1/8-M5C	POC 1/8-N00UC
	POC 03-M6C	POC 1/8-M6C	POC 1/8-N01UC
	POC 04-M3C	POC 5/32-M3C	POC 5/32-U10UC
	POC 04-M5C	POC 5/32-M5C	POC 5/32-N00UC
	POC 04-M6C	POC 5/32-M6C	POC 5/32-N01UC
	POC 04-01C	POC 5/32-01C	POC 1/4-U10UC
	POC 06-M5C	POC 1/4-M5C	POC 1/4-N00UC
	POC 06-M6C	POC 1/4-M6C	POC 1/4-N01UC
POC 06-01C	POC 1/4-01C		

*Hexagonal wrench may be used for a proper tightening.

	MODEL [$\varnothing D$]	
	Tube(Metric)	Tube(Inch)
	PUL 03C	PUL 1/8C
	PUL 04C	PUL 5/32C
PUL 06C	PUL 1/4C	

	MODEL [$\varnothing D-T$]		
	Tube(Metric)-Thread(R)	Tube(Inch)-Thread(R)	Tube(Inch)-Thread(NPT)
	PST 03-M3C	PST 1/8-M3C	PST 1/8-U10UC
	PST 03-M5C	PST 1/8-M5C	PST 1/8-N00UC
	PST 03-M6C	PST 1/8-M6C	PST 1/8-N01UC
	PST 04-M3C	PST 5/32-M3C	PST 5/32-U10UC
	PST 04-M5C	PST 5/32-M5C	PST 5/32-N00UC
	PST 04-M6C	PST 5/32-M6C	PST 5/32-N01UC
	PST 04-01C	PST 5/32-01C	PST 1/4-U10UC
	PST 06-M5C	PST 1/4-M5C	PST 1/4-N00UC
	PST 06-M6C	PST 1/4-M6C	PST 1/4-N01UC
PST 06-01C	PST 1/4-01C		

	MODEL [$\varnothing D$]	
	Tube(Metric)	Tube(Inch)
	PUT 03C	PUT 1/8C
	PUT 04C	PUT 5/32C
PUT 06C	PUT 1/4C	

	MODEL [$\varnothing D-T$]		
	Tube(Metric)-Thread(R)	Tube(Inch)-Thread(R)	Tube(Inch)-Thread(NPT)
	PLL 03-M3C	PLL 1/8-M3C	PLL 1/8-U10UC
	PLL 03-M5C	PLL 1/8-M5C	PLL 1/8-N00UC
	PLL 03-M6C	PLL 1/8-M6C	PLL 1/8-N01UC
	PLL 04-M3C	PLL 5/32-M3C	PLL 5/32-U10UC
	PLL 04-M5C	PLL 5/32-M5C	PLL 5/32-N00UC
	PLL 04-M6C	PLL 5/32-M6C	PLL 5/32-N01UC
	PLL 04-01C	PLL 5/32-01C	PLL 1/4-U10UC
	PLL 06-M5C	PLL 1/4-M5C	PLL 1/4-N00UC
	PLL 06-M6C	PLL 1/4-M6C	PLL 1/4-N01UC
PLL 06-01C	PLL 1/4-01C		

	MODEL [$\varnothing D-T$]		
	Tube(Metric)-Thread(Rc)	Tube(Inch)-Thread(Rc)	Tube(Inch)-Thread(NPT)
	PCF 03-M3C	PCF 1/8-M3C	PCF 1/8-U10UC
	PCF 03-M5C	PCF 1/8-M5C	PCF 1/8-N00UC
	PCF 04-M3C	PCF 5/32-M3C	PCF 5/32-U10UC
PCF 04-M5C	PCF 5/32-M5C	PCF 5/32-N00UC	

	MODEL [$\varnothing D_1-\varnothing D_2$]	
	Tube(Metric)	Tube(Inch)
	PGJ 04-03C	PGJ 06C-1/8C
	PGJ 06-03C	PGJ 1/4C-5/32C
PGJ 06-04C		



PW-C
Reducer Y

MODEL [$\varnothing D_1$ - $\varnothing D_2$]

Tube(Metric)	Tube(Inch)
PW 04-03C	PW 1/8C-03C
PW 06-04C	PW 5/32C-1/8C
	PW 1/4C-5/32C



$\varnothing D_2$
 $\varnothing D_1$

PPF-C
Cap

MODEL [$\varnothing D$]

Tube(Metric)	Tube(Inch)
PPF 03C	PPF 1/8C
PPF 04C	PPF 5/32C
PPF 06C	PPF 1/4C



$\varnothing D$

PWJ-C
Plug-In Reducer Y

MODEL [$\varnothing D_1$ - $\varnothing D_2$]

Tube(Metric)	Tube(Inch)
PWJ 04-03C	PWJ 1/8-03C
PWJ 06-04C	PWJ 5/32C-1/8C
	PWJ 1/4C-5/32C



$\varnothing D_1$
 $\varnothing D_2$

PZA-C
Union Cross

MODEL [$\varnothing D$]

Tube(Metric)	Tube(Inch)
PZA 03C	PZA 1/8C
PZA 04C	PZA 5/32C
PZA 06C	PZA 1/4C



$\varnothing D$

PLJ-C
Plug-In Elbow

MODEL [$\varnothing D$]

Tube(Metric)	Tube(Inch)
PLJ 03C	PLJ 1/8C
PLJ 04C	PLJ 5/32C
PLJ 06C	PLJ 1/4C



$\varnothing D$
 $\varnothing D$

PYJ-C
Plug-In Y

MODEL [$\varnothing D$]

Tube(Metric)	Tube(Inch)
PYJ 03C	PYJ 1/8C
PYJ 04C	PYJ 5/32C
PYJ 06C	PYJ 1/4C



$\varnothing D$
 $\varnothing D$

PMM-C
Bulkhead Union

MODEL [$\varnothing D$]

Tube(Metric)	Tube(Inch)
PMM 03C	PMM 1/8C
PMM 04C	
PMM 06C	



$\varnothing D$
 $\varnothing D$

PG-C
Reducer

MODEL [$\varnothing D_1$ - $\varnothing D_2$]

Tube(Metric)	Tube(Inch)
PG 04-03C	PG 5/32C-1/8C
PG 06-04C	



$\varnothing D_1$
 $\varnothing D_2$

PCC-C

MODEL [$\varnothing D$ -T]

Tube(Metric)-Thread(R)	Tube(Inch)-Thread(R)
PCC 03-M6C	PCC 1/8-M6C
PCC 04-M6C	
PCC 04-M8C	
PCC 06-M8C	

M6 : M6 \times 0.75
M8 : M8 \times 0.75



$\varnothing D$
T

PY-C
Union Y

MODEL [$\varnothing D$]

Tube(Metric)	Tube(Inch)
PY 03C	PY 1/8C
PY 04C	PY 5/32C
PY 06C	PY 1/4C



$\varnothing D$
 $\varnothing D$

PP-C
Plug

MODEL [$\varnothing D$]

Tube(Metric)	Tube(Inch)
PP 03C	PP 1/8C
PP 04C	PP 5/32C
PP 06C	PP 1/4C



$\varnothing D$

SPEED CONTROLLERS

FEATURES

- Speed Controllers precisely permit the optimal rate of airflow for the smooth cylinder movement of a driving device.
- The compact design provides a comparable range of speed as the larger standard speed controllers do.
- Compact and light body is suitable for pneumatic applications where space is at a minimum.
- Unidirectional airflow is available for either exhaust or inlet flow control methods.

SPECIFICATIONS

Compatible Fluid type	Air(No other gases or liquids)	
Operating Pressure Range	0~1.5PSI	0~9.9K gf/cm ² (0~990kPa)
Check valve operating pressure	7.5PSI	0.5Kgf/cm ² (50kPa)
Operating Temperature Range	32~140° F	0~60° C
Recommended Tube Material	Polyurethane and Nylon	

STRUCTURAL DIAGRAM

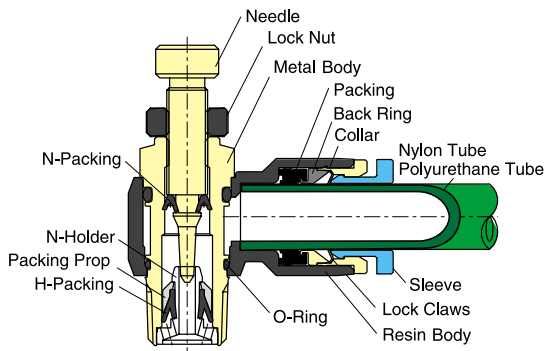

PRODUCTS CODE SYSTEM



- Model Type
- Tube Outer Dia (∅D)

	Metric Size					Inch Size					
Code	04	06	08	10	12	5/32	3/16	1/4	5/16	3/8	1/2
Dia	∅4	∅6	∅8	∅10	∅12	∅5/32	∅3/16	∅1/4	∅5/16	∅3/8	∅1/2

- Thread Size(T)

* Metric Thread & R(PT) Thread

	Metric Size	Taper Pipe Thread			
Code	M5	01	02	03	04
Size	M5 x 0.8	R1/8	R1/4	R3/8	R1/2

* Inch Size(UNF & NPT)

	Unified Fine Thread	American Standard Taper Pipe Thread			
Code	U10U	N01U	N02U	N03U	N04U
Size	10-32UNF	NPT1/8	NPT1/4	NPT3/8	NPT1/2

- Control Method

Type	Meter out Blue	Meter in Red
Sleeve		
Symbol		

- U : Hexagon flat-to-flat inch specification.(NPT)

NSE Elbow	MODEL [∅D-T]				
	Tube(Metric)-Thread(R)	Tube(Inch)-Thread(R)	Tube(Inch)-Thread(NPT)		
	NSE 03-M5	NSE 08-04	NSE 1/4-M5	NSE 5/32-U10U	NSE 5/16-N01U
	NSE 04-M5	NSE 10-02	NSE 1/4-01	NSE 5/32-N01U	NSE 5/16-N02U
	NSE 04-01	NSE 10-03	NSE 1/4-02	NSE 3/16-U10U	NSE 5/16-N03U
	NSE 04-02	NSE 10-04	NSE 5/16-01	NSE 3/16-N01U	NSE 5/16-N04U
	NSE 06-M5	NSE 12-02	NSE 5/16-02	NSE 3/16-N02U	NSE 3/8-N02U
	NSE 06-01	NSE 12-03	NSE 5/16-03	NSE 3/16-N03U	NSE 3/8-N03U
	NSE 06-02	NSE 12-04	NSE 3/8-02	NSE 1/4-U10U	NSE 3/8-N04U
	NSE 06-03		NSE 3/8-03	NSE 1/4-N01U	NSE 1/2-N03U
	NSE 08-01			NSE 1/4-N02U	NSE 1/2-N04U
	NSE 08-02			NSE 1/4-N03U	
	NSE 08-03				

NSE-G Elbow G-Thread	MODEL [∅D-T]	
	Tube(Metric)-Thread(G)	Tube(Inch)-Thread(G)
	NSE 04-G01	NSE 10-G04
	NSE 04-G02	NSE 12-G03
	NSE 06-G01	NSE 12-G04
	NSE 06-G02	
	NSE 06-G03	
	NSE 08-G01	
	NSE 08-G02	
	NSE 08-G03	
	NSE 08-G04	
	NSE 10-G02	
	NSE 10-G03	

NSS Straight	MODEL [∅D-T]				
	Tube(Metric)-Thread(R)	Tube(Inch)-Thread(R)	Tube(Inch)-Thread(NPT)		
	NSS 04-M5	NSS 10-02	NSS 1/4-M5	NSS 5/32-U10U	NSS 5/16-N02U
	NSS 04-01	NSS 10-03	NSS 1/4-01	NSS 5/32-N01U	NSS 5/16-N03U
	NSS 04-02	NSS 10-04	NSS 1/4-02	NSS 3/16-U10U	NSS 5/16-N04U
	NSS 06-M5	NSS 12-02	NSS 5/16-01	NSS 3/16-N01U	NSS 3/8-N02U
	NSS 06-01	NSS 12-03	NSS 5/16-02	NSS 3/16-N02U	NSS 3/8-N03U
	NSS 06-02	NSS 12-04	NSS 5/16-03	NSS 3/16-N03U	NSS 3/8-N04U
	NSS 06-03		NSS 3/8-02	NSS 1/4-U10U	NSS 1/2-N03U
	NSS 08-01		NSS 3/8-03	NSS 1/4-N01U	NSS 1/2-N04U
	NSS 08-02			NSS 1/4-N02U	
	NSS 08-03			NSS 1/4-N03U	
	NSS 08-04			NSS 5/16-N01U	

NSF Union Straight	MODEL [∅D]	
	Tube(Metric)	Tube(Inch)
	NSF 03	NSF 5/32
	NSF 04	NSF 3/16
	NSF 06	NSF 1/4
	NSF 08	NSF 5/16
	NSF 10	NSF 3/8
	NSF 12	NSF 1/2

ROTARY JOINTS

FEATURES

- Two embedded bearings better accommodate high speed rotation and swinging of pneumatic connections.
- Built in bearing accommodates the rotation and swinging of pneumatic connections.
- Rotary joints are constructed to fairly withstand the vibration or tubing movements.

STRUCTURAL DIAGRAM

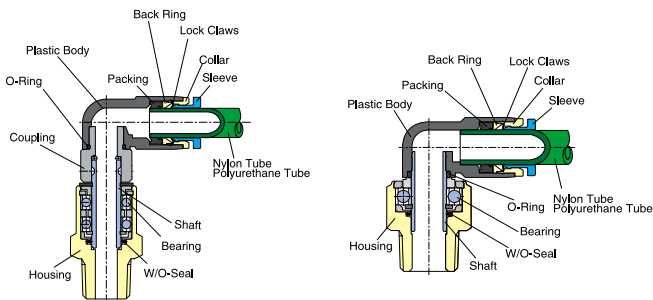

NUMBER OF ROTATION

Model	NHRC, NHRL, NHRS, NHRF				
Tube Dia	∅4	∅6	∅8	∅10	∅12
r. p. m	1500	1200	1200	1000	1000

Model	NRC, NRL				
Tube Dia	∅4	∅6	∅8	∅10	∅12
r. p. m	500	500	400	300	250

SPECIFICATIONS

Compatible Fluid Type	Air(No other gases or liquids)	
Pressure Range	0~150PSI	0~9.9kgf/cm ² (0~990kPa)
Negative Pressure	-29.5inHg	-7.50mmHg(10 Torr)
Temperature Range	32~140°F	0~60 °C

PRODUCT CODE SYSTEM

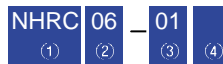

① Model Type

② Tube Outer Dia(∅D)

	Metric Size					Inch Size					
Code	04	06	08	10	12	5/32	3/16	1/4	5/16	3/8	1/2
Dia	∅4	∅6	∅8	∅10	∅12	∅6/32	∅3/16	∅1/4	∅5/16	∅3/8	∅1/2

③ Thread Size(T)

* Metric Thread & R(PT) Thread

	Metric Size		Taper Pipe Thread			
Code	M5	M6	01	02	03	04
Size	M5 × 0.8	M6 × 1.0	R1/8	R1/4	R3/8	R1/2

*Inch Thread (UNF & NPT)

	Unified Fine Thread	American Standard Taper pipe Thread			
Code	U10U	N01U	N02U	N03U	N04U
Size	10-32UNF	NPT1/8	NPT1/4	NPT3/8	NPT1/2

④ U : Hexagon flat-to-flat inch specification.(NPT)

NHRC-G Straight	MODEL [∅D-T]	
	Tube(Metric)-Thread(G)	
	NHRC 04-G01	
	NHRC 06-G01	
	NHRC 06-G02	
	NHRC 08-G01	
	NHRC 08-G02	
	NHRC 08-G03	
	NHRC 10-G03	
	NHRC 10-G04	
	NHRC 12-G03	
	NHRC 12-G04	



NHRS-G Nipple	MODEL [∅D-T]	
	Male Thread(R) - Male Thread(G)	
	NHRS G01-G01	
	NHRS G01-G02	
	NHRS G02-G01	
	NHRS G02-G02	
	NHRS G03-G03	
	NHRS G03-G04	
	NHRS G04-G03	
	NHRS G04-G04	



NRC-G Straight	MODEL [∅D-T]	
	Tube(Metric)-Thread(G)	
	NRC 04-G01	
	NRC 06-G01	
	NRC 06-G02	
	NRC 08-G01	
	NRC 08-G02	
	NRC 08-G03	
	NRC 10-G03	
	NRC 12-G03	

NHRL-G Elbow	MODEL [∅D-T]	
	Tube(Metric)-Thread(G)	
	NHRL 04-G01	
	NHRL 06-G01	
	NHRL 06-G02	
	NHRL 08-G01	
	NHRL 08-G02	
	NHRL 10-G03	
	NHRL 10-G04	
	NHRL 12-G03	



NHRF-G Bush	MODEL [T1-T2]	
	Male Thread(G) - Female Thread(G)	
	NHRF G01-G01	
	NHRF G01-G02	
	NHRF G02-G01	
	NHRF G02-G02	
	NHRF G03-G03	
	NHRF G03-G04	
	NHRF G04-G03	
	NHRF G04-G04	



NRL-G Elbow	MODEL [∅D-T]	
	Tube(Metric)-Thread(G)	
	NRL 04-G01	
	NRL 06-G01	
	NRL 06-G02	
	NRL 08-G01	
	NRL 08-G02	
	NRL 08-G03	
	NRL 10-G03	
	NRL 12-G04	

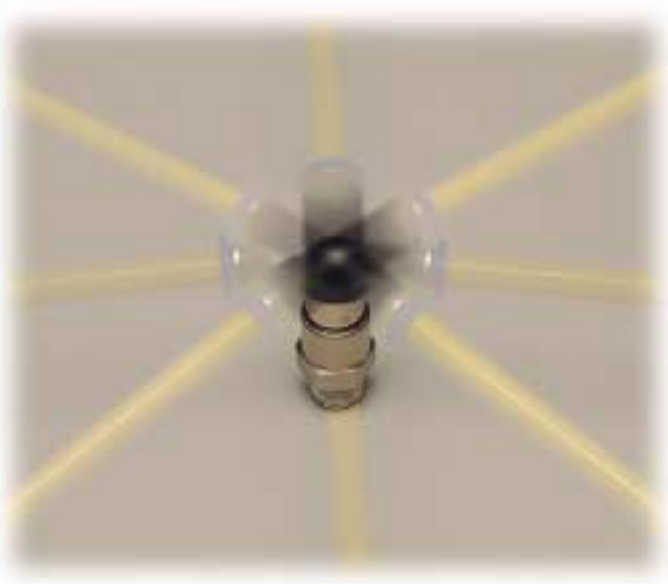

 NHRC Straight  T ØD	MODEL [ØD-T]			
	Tube(Metric)-Thread(R)	Tube(Inch)-Thread(R)	Tube(Inch)-Thread(NPT)	
	NHRC 04-M5	NHRC 1/4-01	NHRC 5/32-U10U	NHRC 1/2-N04U
NHRC 04-M6	NHRC 1/4-02	NHRC 5/32-N01U		
NHRC 04-01	NHRC 5/16-01	NHRC 3/16-N01U		
NHRC 06-01	NHRC 5/16-02	NHRC 3/16-N02U		
NHRC 06-02	NHRC 3/8-03	NHRC 1/4-N01U		
NHRC 08-01	NHRC 3/8-04	NHRC 1/4-N02U		
NHRC 08-02		NHRC 5/16-N01U		
NHRC 10-03		NHRC 5/16-N02U		
NHRC 10-04		NHRC 3/8-N03U		
NHRC 12-03		NHRC 3/8-N04U		
NHRC 12-04		NHRC 1/2-N03U		



 NHRL Elbow  T ØD	MODEL [ØD-T]			
	Tube(Metric)-Thread(R)	Tube(Inch)-Thread(R)	Tube(Inch)-Thread(NPT)	
	NHRL 04-M5	NHRL 1/4-01	NHRL 5/32-U10U	NHRL 1/2-N04U
NHRL 04-M6	NHRL 1/4-02	NHRL 5/32-N01U		
NHRL 04-01	NHRL 5/16-01	NHRL 3/16-N01U		
NHRL 06-01	NHRL 5/16-02	NHRL 3/16-N02U		
NHRL 06-02	NHRL 3/8-03	NHRL 1/4-N01U		
NHRL 08-01	NHRL 3/8-04	NHRL 1/4-N02U		
NHRL 08-02		NHRL 5/16-N01U		
NHRL 10-03		NHRL 5/16-N02U		
NHRL 10-04		NHRL 3/8-N03U		
NHRL 12-03		NHRL 3/8-N04U		
NHRL 12-04		NHRL 1/2-N03U		



 NHR S Nipple  T ₁ T ₂	MODEL [T ₁ -T ₂]	
	Thread(R)-Thread(R)	Thread(NPT)-Thread(NPT)
	NHR S 01-01	NHR S N01-N01U
NHR S 01-02	NHR S N01-N02U	
NHR S 02-01	NHR S N02-N01U	
NHR S 02-02	NHR S N02-N02U	
NHR S 03-03	NHR S N03-N03U	
NHR S 03-04	NHR S N03-N04U	
NHR S 04-03	NHR S N04-N03U	
NHR S 04-04	NHR S N04-N04U	

 NHR F Bush  T ₁ T ₂	MODEL [T ₁ -T ₂]	
	Thread(R)-Thread(Rc)	Thread(NPT)-Thread(NPT)
	NHR F 01-01	NHR F N01-N01U
NHR F 01-02	NHR F N01-N02U	
NHR F 02-01	NHR F N02-N01U	
NHR F 02-02	NHR F N02-N02U	
NHR F 03-03	NHR F N03-N03U	
NHR F 03-04	NHR F N03-N04U	
NHR F 04-03	NHR F N04-N03U	
NHR F 04-04	NHR F N04-N04U	

 NRC Straight  T ØD	MODEL [ØD-T]			
	Tube(Metric)-Thread(R)	Tube(Inch)-Thread(R)	Tube(Inch)-Thread(NPT)	
	NRC 04-M5	NRC 12-03	NRC 1/4-01	NRC 5/32-U10U
NRC 04-M6	NRC 12-04	NRC 1/4-02	NRC 5/32-N01U	NRC 1/2-N04U
NRC 04-01		NRC 5/16-01	NRC 3/16-N01U	
NRC 06-M6		NRC 5/16-02	NRC 3/16-N02U	
NRC 06-01		NRC 5/16-03	NRC 1/4-N01U	
NRC 06-02		NRC 3/8-03	NRC 1/4-N02U	
NRC 08-01		NRC 3/8-04	NRC 5/16-N01U	
NRC 08-02			NRC 5/16-N02U	
NRC 08-03			NRC 5/16-N03U	
NRC 10-03			NRC 3/8-N03U	
NRC 10-04			NRC 3/8-N04U	

 NRL Elbow  T ØD	MODEL [ØD-T]			
	Tube(Metric)-Thread(R)	Tube(Inch)-Thread(R)	Tube(Inch)-Thread(NPT)	
	NRL 04-M5	NRL 12-03	NRL 1/4-01	NRL 5/32-U10U
NRL 04-M6	NRL 12-04	NRL 1/4-02	NRL 5/32-N01U	NRL 1/2-N04U
NRL 04-01		NRL 5/16-01	NRL 3/16-N01U	
NRL 06-M6		NRL 5/16-02	NRL 3/16-N02U	
NRL 06-01		NRL 5/16-03	NRL 1/4-N01U	
NRL 06-02		NRL 3/8-03	NRL 1/4-N02U	
NRL 08-01		NRL 3/8-04	NRL 5/16-N01U	
NRL 08-02			NRL 5/16-N02U	
NRL 08-03			NRL 5/16-N03U	
NRL 10-03			NRL 3/8-N03U	
NRL 10-04			NRL 3/8-N04U	

STOP FITTINGS

FEATURES

- The double-passage mechanism of stop Fittings completely prevent the airflow upon the tubing disconnection and reinitiates the airflow upon the tubing reconnection.
- The complete prevention of airflow upon the tubing disconnection provides safety when repairing the pneumatic equipment.
- Stop Fittings are ideal for the demonstration or the testing of pneumatic connections.

STRUCTURAL DIAGRAM

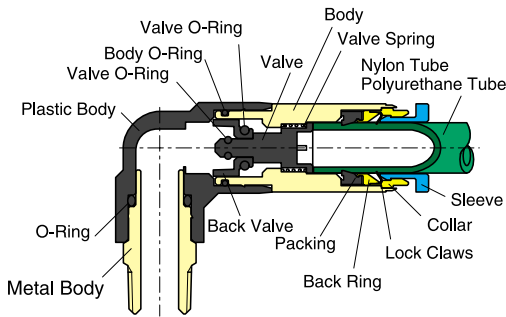

SPECIFICATIONS

Compatible Fluid type	Air(No other gases or liquids)	
Operating Pressure Range	0 ~150PSI	0~9.9kgf/cm ² (0~990kPa)
Operating Temperature Range	32 ~140°F	0~60 °C
Recommended Tube Material	Polyurethane and Nylon	

PRODUCT CODE SYSTEM

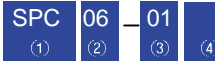

① Model Type

② Tube Outer Dia(∅D)

	Metric Size					Inch Size					
Code	04	06	08	10	12	5/32	3/16	1/4	5/16	3/8	1/2
Dia	∅4	∅6	∅8	∅10	∅12	∅5/32	∅3/16	∅1/4	∅5/16	∅3/8	∅1/2

③ Thread Size(T)

* Metric Thread & R(PT) Thread

	Metric Size		Taper Pipe Size			
Code	M5	M6	01	02	03	04
Size	M5 ×0.8	M6 ×1.0	R1/8	R1/4	R3/8	R1/2

*Inch Thread (UNF & NPT)

	Unified Fine Thread	American Standard Taper Pipe Thread			
Code	U10U	N01U	N02U	N03U	N04U
Size	10-32UNF	NPT1/8	NPT1/4	NPT3/8	NPT1/2

④ U : Hexagon flat-to-flat inch specification.(NPT)

SPL Elbow	MODEL [∅D-T]			
	Tube(Metric)-Thread(R)		Tube(Inch)-Thread(NPT)	
	SPL 04-M5	SPL 10-04	SPL 5/32-U10U	SPL 3/8-N02U
	SPL 04-M6	SPL 12-03	SPL 5/32-N01U	SPL 3/8-N03U
	SPL 04-01		SPL 3/16-U10U	SPL 3/8-N04U
	SPL 06-M5		SPL 3/16-N01U	SPL 1/2-N03U
	SPL 06-01		SPL 3/16-N02U	SPL 1/2-N04U
	SPL 06-02		SPL 1/4-U10U	
	SPL 08-01		SPL 1/4-N01U	
	SPL 08-02		SPL 1/4-N02U	
	SPL 08-03		SPL 5/16-N01U	
	SPL 10-02		SPL 5/16-N02U	
	SPL 10-03		SPL 5/16-N03U	

SPL-G Elbow	MODEL [∅D-T]	
	Tube(Metric)-Thread(G)	
	SPL 04-G01	
	SPL 06-G01	
	SPL 06-G02	
	SPL 08-G02	
	SPL 08-G03	
	SPL 10-G02	
	SPL 10-G03	
	SPL 10-G04	
	SPL 12-G03	

SPC Straight	MODEL [∅D-T]	
	Tube(Metric)-Thread(R)	Tube(Inch)-Thread(NPT)
	SPC 04-01	SPC 5/32-U01U
	SPC 06-01	SPC 3/16-N01U
	SPC 06-02	SPC 3/16-N02U
	SPC 08-02	SPC 1/4-N01U
	SPC 08-03	SPC 1/4-N02U
	SPC 10-02	SPC 5/16-N02U
	SPC 10-03	SPC 5/16-N03U
	SPC 10-04	SPC 3/8-N03U
	SPC 12-03	SPC 3/8-N04U
		SPC 1/2-N03U
		SPC 1/2-N04U

SPC-G Straight	MODEL [∅D-T]	
	Tube(Metric)-Thread(G)	
	SPC 04-G01	
	SPC 06-G01	
	SPC 06-G02	
	SPC 08-G02	
	SPC 08-G03	
	SPC 10-G02	
	SPC 10-G03	
	SPC 10-G04	
	SPC 12-G03	

SPU Union Straight	MODEL [∅D]	
	Tube(Metric)	Tube(Inch)
	SPU 04	SPU 5/32
	SPU 06	SPU 3/16
	SPU 08	SPU 1/4
	SPU 10	SPU 5/16
	SPU 12	SPU 3/8
		SPU 1/2



CHECK VALVES

FEATURES

- Check Valves only permit the uni-directional airflow at a constant pressure and prevent the airflow in the opposite direction.
- Check Valves allow the pneumatic connections under low operating pressure conditions.

STRUCTURAL DIAGRAM ; In Type

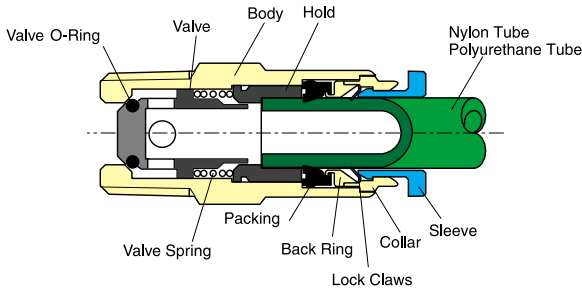

SPECIFICATIONS

Compatible Fluid type	Air(No other gases or liquids)	
Operating Pressure Range	0~150PSI	0~9.9kgf/cm ² (0~990kPa)
Negative Pressure	-29.5inHg	-750mmHg(10Torr)
Operating Temperature Range	32~140°F	0~60°C
Recommended Tube Material	Polyurethane and Nylon	

PCVU Union Straight	MODEL [∅D]	
	Tube(Metric)	Tube(Inch)
	PCVU 04	PCVU 5/32
	PCVU 06	PCVU 3/16
	PCVU 08	PCVU 1/4
	PCVU 10	PCVU 5/16
	PCVU 12	PCVU 3/8
		PCVU 1/2

PRODUCT CODE SYSTEM

PCVC	06	01	A	
(1)	(2)	(3)	(4)	(5)

① Type

② Tube Dia(∅D)

	Metric Size					Inch Size					
Code	04	06	08	10	12	5/32	3/16	1/4	5/16	3/8	1/2
Dia	∅4	∅6	∅8	∅10	∅12	∅5/32	∅3/16	∅1/4	∅5/16	∅3/8	∅1/2

③ Thread Size(T)

* Metric Thread & R(PT) Thread

	Metric Size		Taper Pipe Size			
Code	M5	M6	01	02	03	04
Size	M5×0.8	M6×1.0	R1/8	R1/4	R3/8	R1/2

*Inch Thread (UNF & NPT)

	Unified Fine Thread	American Standard Taper pipe Thread			
Code	U10U	N01U	N02U	N03U	N04U
Size	10-32UNF	NPT1/8	NPT1/4	NPT3/8	NPT1/2

④ Control Method

Type	Meter IN	Meter OUT
Air Flow	Thread to Tube	Tube to Thread
PCVC		
PCVF		
PCVU		In case of PCVU model, you should pipe according to signal of the body.

⑤ U : Hexagon flat-to-flat inch specification.(NPT)

PCVC Straight	MODEL [∅D-T-A/B]	
	Tube(Metric)-Thread(R)	Tube(Inch)-Thread(NPT)
	PCVC 04-M5	PCVC 5/32-U10U
	PCVC 04-M6	PCVC 5/32-N01U
	PCVC 04-01	PCVC 3/16-U10U
	PCVC 06-01	PCVC 3/16-N01U
	PCVC 06-02	PCVC 3/16-N02U
	PCVC 08-01	PCVC 1/4-N01U
	PCVC 08-02	PCVC 1/4-N02U
	PCVC 10-03	PCVC 5/16-N01U
	PCVC 10-04	PCVC 5/16-N02U
	PCVC 12-03	PCVC 3/8-N03U
	PCVC 12-04	PCVC 3/8-N04U

PCVC-G Straight	MODEL [∅D-T]	
	Tube(Metric)-Thread(G)	
	PCVC 04-G01	
	PCVC 06-G01	
	PCVC 06-G02	
	PCVC 08-G01	
	PCVC 08-G02	
	PCVC 10-G03	
	PCVC 10-G04	
	PCVC 12-G03	
	PCVC 12-G04	

PCVF Bush	MODEL [T1-T2-A/B]	
	Thread(R)-Thread(Rc)	Thread(NPT)-Thread(NPT)
	PCVF 01-01	PCVF N01-N01U
	PCVF 02-02	PCVF N02-N02U
	PCVF 03-03	PCVF N03-N03U
	PCVF 04-04	PCVF N04-N04U

PCVF-G Bush	MODEL [T1-T2]	
	Thread(G)-Thread(G)	
	PCVF G01-G01	
	PCVF G02-G02	
	PCVF G03-G03	
	PCVF G04-G04	

BALL VALVES

FEATURES

- Ball Valves are suitable for pneumatic applications in the completely open or closed positions.
- Depending on application conditions, the highly inert PPS resin body construction allows air or water services.
- The sectional dimension of the compact body is proportional to the tube size optimizes flow and efficiency.
- Specially designed handle enables increased turning leverage for easy opening and closing.

STRUCTURAL DIAGRAM

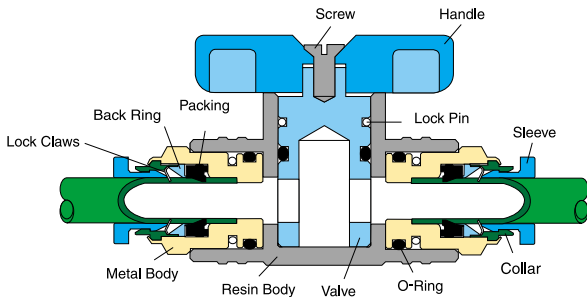

SPECIFICATIONS

Compatible Fluid type	Air & Water	
Operating Pressure Range	0~150PSI	0~9.9Kgf/cm ² (0~990kPa)
Negative pressure	-29.5 in Hg	-750mmHg(10Torr)
Operating Temperature Range	32~140° F	0~60°C
Recommended Tube Material	Polyurethane and Nylon	

PRODUCTS CODE SYSTEM

BC 20 - 08 02
 (1) (2) (3) (4)

- ① Type
- ② Effective Sectional area

Metric Size		
Code	20	60
Size	20mm ²	60mm ²

- ③ Tube Dia (∅D)

Metric Size				
Code	06	08	10	12
Size	∅6	∅8	∅10	∅12

- ④ Thread Size(T)

*R (PT)Thread				
		Taper Pipe Thread		
Code	01	02	03	04
Size	R1/8	R1/4	R3/8	R1/2



20 Series

		MODEL [∅D1- ∅D2]	
		Tube(Metric)	Tube(Inch)
BUC Union		BUC 20-0606	BUC 20 1/4-1/4
		BUC 20-0808	BUC 20 5/16-5/16
BUG Reducing Union		BUG 20-0806	BUG 20 5/16-1/4

		MODEL [∅D1- ∅D2]	
		Tube(Metric)	Tube(Inch)
BM Bulkhead Union		BM 20-0606	BM 20 1/4-1/4
		BM 20-0806	BM 20 5/16-5/16
		BM 20-0808	BM 20 5/16-1/4

		MODEL [∅D-T]	
		Tube(Metric)-Thread(R)	Tube(Inch)-Thread(NPT)
BL Elbow		BL 20-0601	BL 20 1/4-N01U
		BL 20-0602	BL 20 1/4-N02U
		BL 20-0603	BL 20 1/4-N03U
		BL 20-0801	BL 20 5/16-N01U
		BL 20-0802	BL 20 5/16-N02U
		BL 20-0803	BL 20 5/16-N03U

		MODEL [∅D-T]	
		Tube(Metric)-Thread(R)	Tube(Inch)-Thread(NPT)
BC Straight		BC 20-0601	BC 20 1/4-N01U
		BC 20-0602	BC 20 1/4-N02U
		BC 20-0603	BC 20 1/4-N03U
		BC 20-0801	BC 20 5/16-N01U
		BC 20-0802	BC 20 5/16-N02U
		BC 20-0803	BC 20 5/16-N03U

<p>BUL Union Elbow BLG Reducing Union Elbow</p> <p>$\varnothing D_1$ $\varnothing D_2$</p>	MODEL [$\varnothing D_1$ - $\varnothing D_2$]	
	Tube(Metric)	Tube(Inch)
	BUL 20-0606	BUL 20 1/4-1/4
	BUL 20-0808	BUL 20 5/16-5/16
	BLG 20-0608	BLG 20 1/4-5/16
	BLG 20-0806	BLG 20 5/16-1/4

<p>BLM Bulkhead Union Elbow</p> <p>$\varnothing D_1$ $\varnothing D_2$</p>	MODEL [$\varnothing D_1$ - $\varnothing D_2$]	
	Tube(Metric)	Tube(Inch)
	BLM 20-0606	BLM 20 1/4-1/4
	BLM 20-0806	BLM 20 5/16-1/4
	BLM 20-0808	BLM 20 5/16-5/16

60 Series

<p>BUC Union BUG Reducing Union</p> <p>$\varnothing D_1$ $\varnothing D_2$</p>	MODEL [$\varnothing D_1$ - $\varnothing D_2$]	
	Tube(Metric)	Tube(Inch)
	BUC 60-1010	BUC 60 3/8-3/8
	BUC 60-1212	BUC 60 1/2-1/2
	BUG 60-1210	BUG 60 1/2-3/8

<p>BM Bulkhead Union</p> <p>$\varnothing D_1$ $\varnothing D_2$</p>	MODEL [$\varnothing D_1$ - $\varnothing D_2$]	
	Tube(Metric)	Tube(Inch)
	BM 60-1010	BM 60 3/8-3/8
	BM 60-1210	BM 60 1/2-3/8
	BM 60-1212	BM 60 1/2-1/2

<p>BL Elbow</p> <p>$\varnothing D$ T</p>	MODEL [$\varnothing D$ -T]	
	Tube(Metric)-Thread(R)	Tube(Inch)-Thread(NPT)
	BL 60-1002	BL 60 3/8-N02U
	BL 60-1003	BL 60 3/8-N03U
	BL 60-1004	BL 60 3/8-N04U
	BL 60-1202	BL 60 1/2-N02U
	BL 60-1203	BL 60 1/2-N03U
BL 60-1204	BL 60 1/2-N04U	

<p>BC Straight</p> <p>T $\varnothing D$</p>	MODEL [$\varnothing D$ -T]	
	Tube(Metric)-Thread(R)	Tube(Inch)-Thread(NPT)
	BC 60-1002	BC 60 3/8-N02U
	BC 60-1003	BC 60 3/8-N03U
	BC 60-1004	BC 60 3/8-N04U
	BC 60-1202	BC 60 1/2-N02U
	BC 60-1203	BC 60 1/2-N03U
BC 60-1204	BC 60 1/2-N04U	

<p>BUL Union Elbow BLG Reducing Union Elbow</p> <p>$\varnothing D_1$ $\varnothing D_2$</p>	MODEL [$\varnothing D_1$ - $\varnothing D_2$]	
	Tube(Metric)	Tube(Inch)
	BUL 60-1010	BUL 60 3/8-3/8
	BUL 60-1212	BUL 60 1/2-1/2
	BLG 60-1012	BLG 60 3/8-1/2
	BLG 60-1210	BLG 60 1/2-3/8

<p>BLM Bulkhead Union Elbow</p> <p>$\varnothing D_1$ $\varnothing D_2$</p>	MODEL [$\varnothing D_1$ - $\varnothing D_2$]	
	Tube(Metric)	Tube(Inch)
	BLM 60-1010	BLM 60 3/8-3/8
	BLM 60-1210	BLM 60 1/2-3/8
	BLM 60-1212	BLM 60 1/2-1/2

■ Fittings with G Thread(O-Ring)

20 Series

<p>BL-G Elbow</p> <p>$\varnothing D$ T</p>	MODEL [$\varnothing D$ -T]	
	Tube(Metric)-Thread(G)	
	BL 20-06G01	
	BL 20-06G02	
	BL 20-06G03	
	BL 20-08G01	
	BL 20-08G02	
	BL 20-08G03	

<p>BC-G Straight</p> <p>$\varnothing D$ T</p>	MODEL [$\varnothing D$ -T]	
	Tube(Metric)-Thread(G)	
	BC 20-06G01	
	BC 20-06G02	
	BC 20-06G03	
	BC 20-08G01	
	BC 20-08G02	
	BC 20-08G03	

60 Series

<p>BL-G Elbow</p> <p>$\varnothing D$ T</p>	MODEL [$\varnothing D$ -T]	
	Tube(Metric)-Thread(G)	
	BL 60-10G02	
	BL 60-10G03	
	BL 60-10G04	
	BL 60-12G02	
	BL 60-12G03	
	BL 60-12G04	

<p>BC-G Straight</p> <p>$\varnothing D$ T</p>	MODEL [$\varnothing D$ -T]	
	Tube(Metric)-Thread(G)	
	BC 60-10G02	
	BC 60-10G03	
	BC 60-10G04	
	BC 60-12G02	
	BC 60-12G03	
	BC 60-12G04	

MAIN BLOCKS

FEATURES

- Various combinations of manifold blocks may be constructed for concentrated branching.
- Main Blocks provide comparable flow rates to steel piping.

STRUCTURAL DIAGRAM

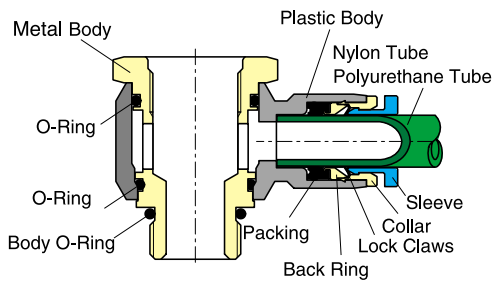

SPECIFICATIONS

Compatible Fluid type	Air(No other gases or liquids)	
Operating Pressure Range	0~150PSI	0~9.9kgf/cm ² (0~990kPa)
Negative Pressure	-29.5inHg	-750mmHg(10Torr)
Operating Temperature Range	32~140°F	0~60 °C
Recommended Tube Material	Polyurethane and Nylon	

PRODUCT CODE SYSTEM

BHF 14 - 08

① ② ③

- ① Type
- ② Connecting Thread Size(R)

Metric Size				
Code	08	12	14	18
Size	M8 x1.0	M12 x1.0	M14 x1.0	M18 x1.0

Thread Size						
Code	M5	M6	01	02	03	04
Size	M5 x0.8	M6 x0.1	R1/8	R1/4	R3/8	R1/2

- ③ Tube Outer Dia(ØD)

Metric Size					
Code	04	06	08	10	12
Dia	Ø04	Ø06	Ø08	Ø10	Ø12

BHF
Universal Quick



T ØD

MODEL [T-ØD]
Thread(M)-Tube(Metric)

BHF 0804
BHF 0806
BHF 1206
BHF 1208
BHF 1408
BHF 1410
BHF 1412
BHF 1812

BHMR
Universal Rc Thread



T1 T2

MODEL [T1-T2]
Thread(M)-Thread(Rc)

BHMR 08M5
BHMR 08M6
BHMR 12M6
BHMR 1201
BHMR 1401
BHMR 1402
BHMR 1802

BCM
Cap



T

MODEL [T]
Thread(M)

BCM 08
BCM 12
BCM 14
BCM 18

BHWF
Universal Branch



T ØD

MODEL [T-ØD]
Thread(M)-Tube(Metric)

BHWF 1410
BHWF 1812

BRM
Bush



T1 T2

MODEL [T1-T2]
Thread(M)-Thread(Rc)

BRM 08M5
BRM 12M6
BRM 1401
BRM 1802

BMF
Bulkhead Reducer



T ØD1

MODEL [T-ØD]
Thread(M)-Tube(Metric)

BMF 0804
BMF 0806
BMF 1206
BMF 1208
BMF 1210
BMF 1408
BMF 1410
BMF 1412
BMF 1812

BHM
Universal M Thread



T2 T1

MODEL [T1-T2]
Thread(M)-Thread(M)

BHM 1208
BHM 1412
BHM 1414
BHM 1814

BMM
Bush



T1 T2

MODEL [T1-T2]
Thread(M)-Thread(M)

BMM 1208
BMM 1412
BMM 1814

BMR
Bush



T1 T2

MODEL [T1-T2]
Thread(M)-Thread(R)

BMR 0801
BMR 1201
BMR 1202
BMR 1203
BMR 1402
BMR 1403
BMR 1404
BMR 1803
BMR 1804



	BL Elbow	MODEL [T1-T2] Thread(M)-Thread(R)
		BL 0801
		BL 1201
		BL 1202
		BL 1402
		BL 1403
		BL 1404
		BL 1803
		BL 1804

	BUMR Socket	MODEL [T1-T2] Thread(M)-Thread(Rc)
		BUMR 0801
		BUMR 1202
		BUMR 1403
		BUMR 1804

	BPM Plug	MODEL [T] Thread(M)
		BPM 08
		BPM 12
		BPM 14
		BPM 18

	BUMM Nipple	MODEL [T] Thread(M)
		BUMM 0808
		BUMM 1212
		BUMM 1414
		BUMM 1818

SILENCERS

FEATURES

- Silencers are effective in reducing noise generated by the release of pressurized air through the exhaust port.
- The plastic material provides corrosion resistance, light weight, longer product life, low replacement cost, and easy cleaning with soap or solvents.
- A unique design minimizes the interference in relation to the surrounding pneumatic installations.

SPECIFICATIONS

Model Application	ST-01	ST-02	ST-03	ST-04	STM-02	STM-03
Port	R1/8	R1/4	R3/8	R1/2	R1/4	R3/8
Max Working Pressure	7Kgf/cm ² (700kPa)			9.9Kgf/cm ² (900kPa)	7Kgf/cm ² (700kPa)	

PRODUCT CODE SYSTEM

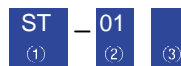

① Type(ØD)

MODEL		
Code	ST	STM
Dia	STANDARD	MANIFOLD

② Thread Size(R)

Thread Size				
Code	01	02	03	04
Size	R1/8	R1/4	R3/8	R1/2

③ Color

B
Black

	ST Silencers	MODEL [T] Thread(R)
		ST 01
		ST 02
		ST 03
		ST 04
		STM 02
		STM 03

	ST-B Silencers Black	MODEL [T] Thread(R)
		ST 01B
		ST 02B
		ST 03B
		ST 04B
		STM 02B
		STM 03B

HAND VALVES

FEATURES

- The Hand Valves are designed to regulate air flow manually.
- When closed, the three-way control valve prevents in-coming air and discharges the residual air on the output side.
- Hand Valves are useful in checking or repairing the devices in a safe manner.

STRUCTURAL DIAGRAM

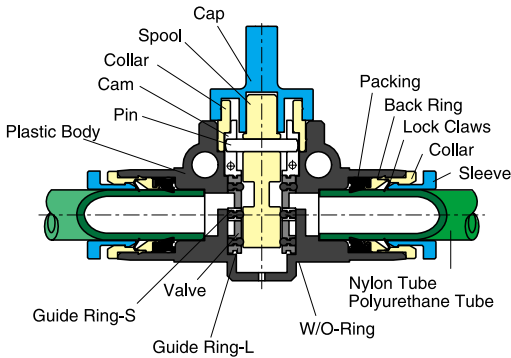

SPECIFICATIONS

Compatible Fluid type	Air(No other gases or liquids)	
Operating Pressure Range	0~150PSI	0~9.9Kgf/cm ² (0~990kPa)
Negative pressure	-29.5 inHg	-750mmHg(10Torr)
Operating Temperature Range	32~140° F	0~60° C
Recommended Tube Material	Polyurethane and Nylon	

PRODUCTS CODE SYSTEM

HVFS ① **06** - **01** ② ③

① Model Type

② Tube Dia (∅D)

Code	Metric Size			
	06	08	10	12
Dia	∅6	∅8	∅10	∅12

③ Thread Size(R)

Code	Thread Size			
	01	02	03	04
Size	R1/8	R1/4	R3/8	R1/2



HVSS
Nipple

MODEL [T1-T2]
Thread(R)

HVSS 01-01
HVSS 02-01
HVSS 02-02
HVSS 03-02
HVSS 03-03
HVSS 04-03
HVSS 04-04

T1 T2

HVSS-G
Nipple

MODEL [T-T]
Male Thread(G) - Male Thread(G)

HVSS G01-G01
HVSS G02-G01
HVSS G02-G02
HVSS G03-G02
HVSS G03-G03
HVSS G04-G03
HVSS G04-G04

∅D T

HVFS
Straight Fitting-Thread

MODEL [∅D-T]
Tube(Metric)-Thread(R)

HVFS 06-01	HVFS 12-04
HVFS 06-02	
HVFS 06-03	
HVFS 08-01	
HVFS 08-02	
HVFS 08-03	
HVFS 10-02	
HVFS 10-03	
HVFS 10-04	
HVFS 12-02	
HVFS 12-03	

∅D T

HVFS-G
Straight Fitting-G Thread

MODEL [∅D-T]
Tube(Metric)-Thread(G)

HVFS 06-G01	HVFS 12-G04
HVFS 06-G02	
HVFS 06-G03	
HVFS 08-G01	
HVFS 08-G02	
HVFS 08-G03	
HVFS 10-G02	
HVFS 10-G03	
HVFS 10-G04	
HVFS 12-G02	
HVFS 12-G03	

∅D T

HSV(M)
Nipple Slide Type

MODEL [T]
Thread(R)

HSV-M-M5
HSV-M-1/8
HSV-M-1/4
HSV-M-3/8
HSV-M-1/2
HSV-M-3/4

T

HVSF
Straight Thread-Fitting

MODEL [∅D-T]
Tube(Metric)-Thread(R)

HVSF 06-01	HVSF 12-04
HVSF 06-02	
HVSF 06-03	
HVSF 08-01	
HVSF 08-02	
HVSF 08-03	
HVSF 10-02	
HVSF 10-03	
HVSF 10-04	
HVSF 12-02	
HVSF 12-03	

∅D T

HVSF-G
Straight G Thread-Fitting

MODEL [∅D-T]
Tube(Metric)-Thread(G)

HVSF 06-G01	HVSF G12-04
HVSF 06-G02	
HVSF 06-G03	
HVSF 08-G01	
HVSF 08-G02	
HVSF 08-G03	
HVSF 10-G02	
HVSF 10-G03	
HVSF 10-G04	
HVSF 12-G02	
HVSF 12-G03	

∅D T

HVFF
Union Straight

MODEL [∅D1- ∅D2]
Tube(Metric)

HVFF 06-06
HVFF 08-06
HVFF 08-08
HVFF 10-10
HVFF 12-10
HVFF 12-12

∅D1 ∅D2

AIR GUN

FEATURES

- Available in 3 different nozzle lengths
- Easy to consistently regulate the variable air flow
- Ergonomically designed and lightweight
- Impact resistant plastic body

SPECIFICATIONS

Compatible Fluid type	Air (No other gases or liquids)	
Operating Pressure Range	15~150PSI	1.0~9.9Kg/cm ² (1~990kPa)
Operating Temperature Range	32~140°F	0~60°C

PRODUCT CODE SYSTEM

AG - S - 02 - B
 (1) (2) (3) (4)

- ① Type
- ② Nozzle Type

Metric Size						
Type	S	M	L	SP	MP	LP
Size	Short	Medium	Long	Short	Medium	Long

- ③ Thread Size(RC)

Metric Size			
Code	02	03	P
Size	Rc1/4	Rc3/8	Coupler

- ④ Color

B	R	BU
Black	Red	Blue

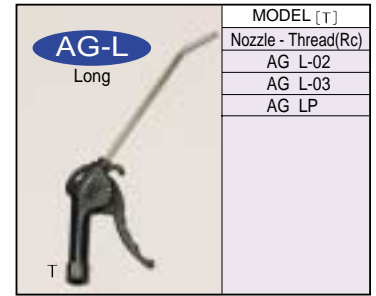
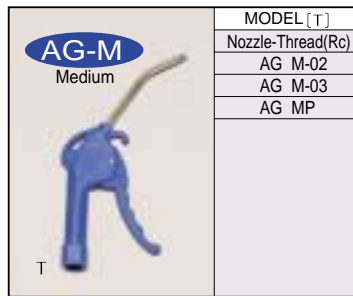
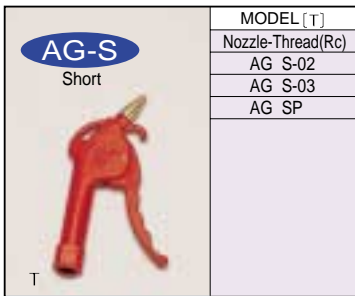

TUBE CUTTER

FEATURES

- A Safe, efficient, accurate tool for cutting tubing squarely



SPECIFICATIONS

Available Tubing	Polyurethane and Nylon
Cutting Outer Dia	∅3.0 ~ ∅12.0
Material	Polyacetal, Stainless steel
Standard Color	Blue

PRODUCT CODE SYSTEM

Tube Cutter

- ① Model Type

POLYETHYLENE TUBINGS

FEATURES

- Flexible, lightweight : durable
- Low cost alternative
- FDA grade approved : optional

APPLICATIONS

- Air Lines
- Chemical Line
- Instrumentation
- Fluid Lines

SPECIFICATIONS

Compatible Fluid type	Air (No other gases or liquids)	
Operating Pressure Range	0~100PSI	0~7Kgf/cm ² (0~700kPa)
Negative Pressure Range	-29.5inHg	-750mmHg(10Torr)
Operating Temperature Range	5~140°F	-15~60°C

PRODUCT CODE SYSTEM

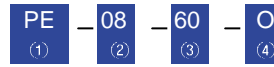

① Model Type

②③ Tube Dia(∅D)

	Metric Size					
Code	0420	0425	0640	0860	1080	1290
Outer Dia	∅4	∅4	∅6	∅8	∅10	∅12
Inner Dia	∅2	∅2.5	∅4	∅6	∅8	∅9

	Inch Size						
Code	1/8	5/32	3/16	1/4	5/16	3/8	1/2
Outer Dia	∅1/8	∅5/32	∅3/16	∅1/4	∅5/16	∅3/8	∅1/2

④ Color of Tubing

- clear
- Black
- Red
- Blue
- Yellow
- Green

MODEL (Out-In)	Tube (Metric)	
	Tube (Metric)	Tube (Inch)
	PE 4.0-2.0	PE 1/8
	PE 4.0-2.5	PE 5/32
	PE 6.0-4.0	PE 3/16
	PE 8.0-6.0	PE 1/4
	PE 10.0-8.0	PE 5/16
	PE 12.0-9.0	PE 3/8
		PE 1/2

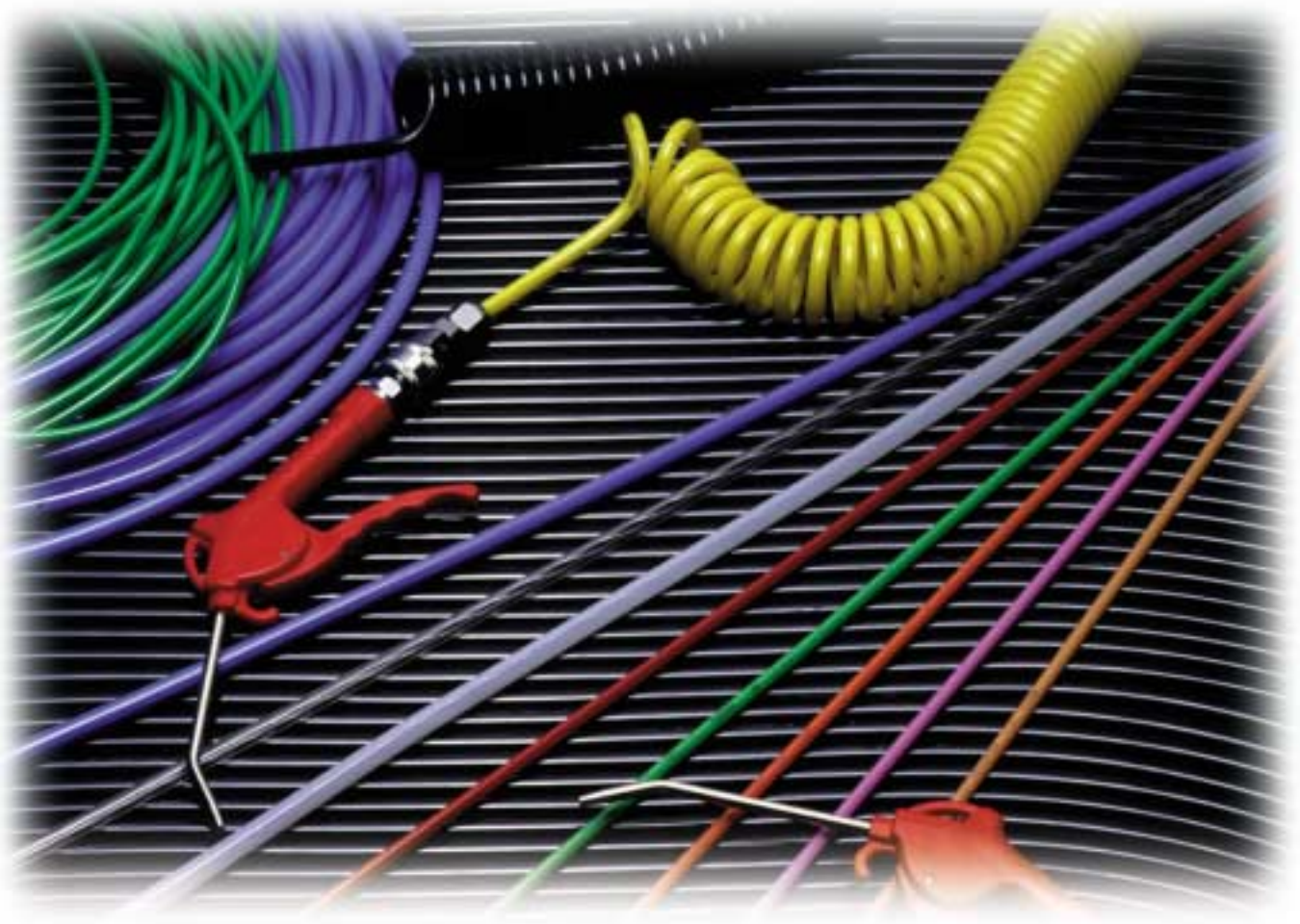

NYLON 11 TUBINGS

FEATURES

- Nylon 11 tubing is made from a semi-rigid high strength material without plasticizers, to provide better resistance against chemicals, high ambient temperature, and moist absorption.
- High tensile strength of Nylon 11 material provides optimal usage under conditions of high pressure, temperature, and vibration.

APPLICATIONS

- Lubricating Systems
- Marine Controls Systems
- Chemical and Oil Process Lines.
- Medical and Laboratory Industry
- Food Processing Industry

SPECIFICATIONS

Compatible Fluid type	Air (No other gases or liquids)	
Operating Pressure Range	0~150PSI	0~9k g/cm ² (0~900kPa)
Negative Pressure Range	-29.5nHg	-750mmHg(1.0Torr)
Operating Temperature Range	5~140°F	-15~60°C

PRODUCT CODE SYSTEM

N (1) - 08 (2) - 60 (3) - O (4)

① Model Type

②③ Tube Dia(∅D)

Code	Metric Size							
	0320	0420	0425	0640	0860	1080	1290	1613
Outer Dia	∅3	∅4	∅4	∅6	∅8	∅10	∅12	∅16
Inner Dia	∅2	∅2	∅2.5	∅4	∅6	∅8	∅9	∅13

Code	Inch Size							
	1/8	5/32	3/16	1/4	5/16	3/8	1/2	5/8
Outer Dia	∅1/8	∅5/32	∅3/16	∅1/4	∅5/16	∅3/8	∅1/2	∅5/8

④ Color of Tubing

clear Black Red Blue Yellow Green



MODEL (Out-In)		
Tube(Metric)	Tube(Inch)	
N 3.0-2.0	N 1/8	
N 4.0-2.0	N 5/32	
N 4.0-2.5	N 3/16	
N 6.0-4.0	N 1/4	
N 8.0-6.0	N 5/16	
N 10.0-8.0	N 3/8	
N 12.0-9.0	N 1/2	
N 16.0-12.0	N 5/8	
N 16.0-13.0		

POLYURETHANE TUBINGS

FEATURES

- Polyurethane tubing is made from a high quality polymer that exhibits the characteristics of elasticity and chemical resistance.
- Polyurethane material has the exceptional physical properties of durability and anti-abrasion, yet flexible and ideal for various critical pneumatic applications.

APPLICATIONS

- Air Tools
- Industrial Robotics
- Pneumatic Systems
- Lubricating Systems

SPECIFICATIONS

Compatible Fluid type	Air (No other gases or liquids)	
Operating Pressure Range	0~150PSI	0~9k g/cm ² (0~900kPa)
Operating Negative Pressure	-29.5nHg	-750mmHg(1.0Torr)
Operating Temperature Range	5~140°F	-15~60°C

PRODUCT CODE SYSTEM

U (1) - 08 (2) - 50 (3) - B (4)

① Model Type

②③ Tube Dia(∅D)

Code	Metric Size									
	0320	0420	0425	0640	0850	0855	1065	1280	1290	1611
Outer Dia	∅3	∅4	∅4	∅6	∅8	∅8	∅10	∅12	∅12	∅16
Inner Dia	∅2	∅2	∅2.5	∅4	∅5	∅5.5	∅6.5	∅8	∅9	∅11

Code	Inch Size							
	1/8	5/32	3/16	1/4	5/16	3/8	1/2	5/8
Outer Dia	∅1/8	∅5/32	∅3/16	∅1/4	∅5/16	∅3/8	∅1/2	∅5/8

④ Color of Tubing

clear Black Red Blue Yellow Green



MODEL (Out-In)		
Tube(Metric)	Tube(Inch)	
U 3.0-2.0	U 1/8	
U 4.0-2.0	U 5/32	
U 4.0-2.5	U 3/16	
U 6.0-4.0	U 1/4	
U 8.0-5.0	U 5/16	
U 8.0-5.5	U 3/8	
U 10.0-6.5	U 1/2	
U 12.0-8.0	U 5/8	
U 12.0-9.0		
U 16.0-11.0		
U 16.0-12.0		



MODEL (Out-Length)						
	Tube(Metric)			Tube(Inch)		
	UC 3-1	UC 6-10	UC 10-20	UC 1/8-1	UC 3/16-10	UC 5/16-20
UC 3-2	UC 6-15	UC 12-5	UC 1/8-2	UC 3/16-20	UC 3/8-5	
UC 3-5	UC 6-20	UC 12-10	UC 1/8-5	UC 1/4-2	UC 3/8-10	
UC 4-2	UC 8-5	UC 12-15	UC 5/32-2	UC 1/4-5	UC 3/8-15	
UC 4-5	UC 8-10	UC 12-20	UC 5/32-5	UC 1/4-10	UC 3/8-20	
UC 4-10	UC 8-15		UC 5/32-10	UC 1/4-15	UC 1/2-5	
UC 4-15	UC 8-20		UC 5/32-15	UC 1/4-20	UC 1/2-10	
UC 4-20	UC 10-5		UC 5/32-20	UC 5/16-5	UC 1/2-15	
UC 6-2	UC 10-10		UC 3/16-2	UC 5/16-10	UC 1/2-20	
UC 6-5	UC 10-15		UC 3/16-5	UC 5/16-15		

ACE COUPLER

Valve Symbols One-way shut-off	Working Pressure 15kgf/cm ²	Applicable Fluids Air Water Oil
--	--	---

FEATURES

- Uni-directional shut-off coupler with an automatic shut-off valve built in the socket.
- Recommended for piping of compressed air connections.

STRUCTURAL DIAGRAM

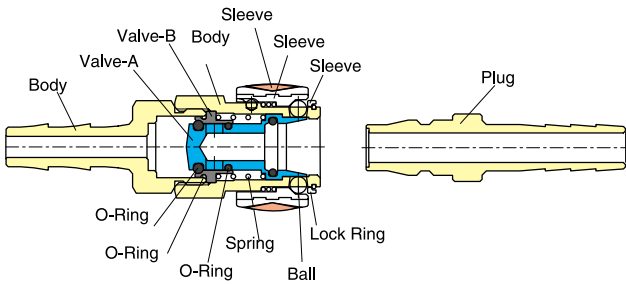

SPECIFICATIONS

Compatible Fluid type	Air, Water, Oil		
Material	Brass(chrome-plated)	Steel(chrome-plated)	Stainless steel
Working Pressure Range	10kgf/cm ² (1000kPa)	10kgf/cm ² (1000kPa)	15kgf/cm ² (1500kPa)
Maximum Pressure	15kgf/cm ² (1500kPa)	20kgf/cm ² (2000kPa)	20kgf/cm ² (2000kPa)

PRODUCT CODE SYSTEM

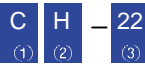

① Model

C	Plug
H	Socket

② Type

H	Hose Stem
M	Male Thread
F	Female Thread
N	Nut

③ Thread Size(R)

Size	22	23	24	44	46	48
H	9.0	11.0	15.0	15.0	21.0	27.0
M	R1/4	R 3/8	R1/2	R1/2	R3/4	R1
F	Rc1/4	Rc 3/8	Rc1/2	Rc1/2	Rc3/4	Rc1
N	8×5	10×6.5	12×8			

 CH Plug Nipple	MODEL [T]
	Hose Stem
	CH 22
	CH 23
	CH 24
	CH 44
	CH 46
	CH 48

 CM Plug Male	MODEL [T]
	Male Thread(R)
	CM 21
	CM 22
	CM 23
	CM 24
	CM 44
	CM 46
CM 48	

 CF Plug Female	MODEL [T]
	Female Thread(Rc)
	CF 22
	CF 23
	CF 24
	CF 44
	CF 46
	CF 48

 NH Auto Socket Nipple	MODEL [T]
	Hose Stem
	NH 22
	NH 23
NH 24	

 NM Auto Socket Male	MODEL [T]
	Male Thread(R)
	NM 22
	NM 23
NM 24	

 NF Auto Socket Female	MODEL [T]
	Female Thread(Rc)
	NF 22
	NF 23
NF 24	

 HH Socket Nipple	MODEL [T]
	Hose Stem
	HH 22
	HH 23
	HH 24
	HH 44
	HH 46
	HH 48

 HM Socket Male	MODEL [T]
	Male Thread(R)
	HM 22
	HM 23
	HM 24
	HM 44
	HM 46
	HM 48

 HF Socket Female	MODEL [T]
	Female Thread(Rc)
	HF 22
	HF 23
	HF 24
	HF 44
	HF 46
	HF 48

HP COUPLER

Valve Symbols Working Pressure Applicable Fluids

Two-way shut-off 70kgf/cm²

Water Oil Gasoline
Steam Chemicals Air

FEATURES

- Bi-directional shut off coupler with an automatic shut off valve built in the socket and plug.
- Recommended for piping of chemicals, steam and oil.

STRUCTURAL DIAGRAM

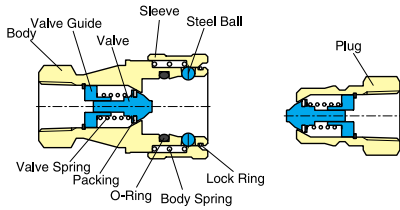

SPECIFICATIONS

Compatible Fluid type	Air, Water, Oil, Steam, Medicines, Gasolin (Another way air for Special Order)
Material	Brass, Steel, Stainless steel
Temperature Range	-20~80 °C

PRODUCT CODE SYSTEM



① Thread Size(Rc)

		Thread Size								
Code	1	2	3	4	6	8	10	12	16	
Size	Rc1/8	Rc1/4	Rc3/8	Rc1/2	Rc3/4	Rc1	Rc1 1/4	Rc1 1/2	Rc2	

② Type

③ Applicable fluid

Code	A	W	O	S	G	C
Size	Air	Water	Oil	Steam	Gas	Chemicals

④ Material

Code	B	S	U
Material	Brass	Steel	Stainless steel

CN
Plug Nut

MODEL [∅D]
Hose Nut(∅D)
CN 21(8 ×5)
CN 23(10 ×6.5)
CN 24(12 ×8)

∅D

NN
Auto Socket Nut

MODEL [∅D]
Hose Nut(∅D)
NN 21(8 ×5)
NN 23(10 ×6.5)
NN 24(12 ×8)

∅D

HN
Socket Nut

MODEL [∅D]
Hose Nut(∅D)
HN 21(8 ×5)
HN 23(10 ×6.5)
HN 24(12 ×8)

∅D

C
Plug Female

MODEL [T]
Female Thread(Rc)
1C
2C
3C
4C
6C
8C
10C
12C
16C

T

H
Socket Female

MODEL [T]
Female Thread(Rc)
1H
2H
3H
4H
6H
8H
10H
12H
16H

T



TWO-TOUCH FITTINGS

FEATURES

- The lock-nut mechanism provides exceptional resistance to vibration and piping movements.
- Proper tightening with the lock-nut ensures pneumatic connections with no air leakage.
- Excellent anti-corrosion and anti-contamination properties against foreign substances.
- The plastic composition has non-magnetic properties with longer product life.

STRUCTURAL DIAGRAM

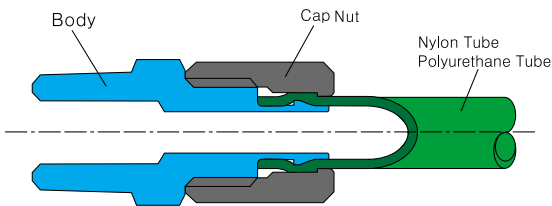

SPECIFICATIONS

Compatible Fluid type	Air (No other gases or liquids)	
Operating Pressure Range	0~150PSI	0~9.9kgf/cm ² (0~990kPa)
Negative pressure	-29.5in Hg	-750mm Hg (10Tor)
Operating Temperature Range	32~140°F	0~60°C
Recommended Tube Material	Polyurethane	

PRODUCT CODE SYSTEM

CK 04 - 01
 (1) (2) (3)

① Model Type

Code	Metric Size			
	TC	TL	TUT	THT
Type	STRAIGHT	ELBOW	UNION	TEE
				ROTATION

② Tube Dia (∅D)

Code	Metric Size				
	04	06	08	10	12
Dia	∅4 × ∅2.5	∅6 × ∅4	∅8 × ∅5	∅10 × ∅6.5	∅12 × ∅8

③ Thread Size(R)

Code	Thread Size			
	01	02	03	04
Size	R1/8	R1/4	R3/8	R1/2

TC
Straight



∅D T

MODEL [∅D-T]
Tube(Metric)-Thread(R)
TC 04-01
TC 04-02
TC 06-01
TC 06-02
TC 08-01
TC 08-02
TC 08-03
TC 10-02
TC 10-03
TC 12-03
TC 12-04

THT(D1)
Single Universal Tee



∅D T

MODEL [∅D-T]	
Tube(Metric)-Thread(R)	
THT 04-01D1	THT 12-02D1
THT 04-02D1	THT 12-03D1
THT 06-01D1	THT 12-04D1
THT 06-02D1	
THT 08-01D1	
THT 08-02D1	
THT 08-03D1	
THT 10-02D1	
THT 10-03D1	
THT 10-04D1	

THL(D1)
Single Universal Elbow



∅D T

MODEL [∅D-T]	
Tube(Metric)-Thread(R)	
THL 04-01D1	THL 12-02D1
THL 04-02D1	THL 12-03D1
THL 06-01D1	THL 12-04D1
THL 06-02D1	
THL 08-01D1	
THL 08-02D1	
THL 08-03D1	
THL 10-02D1	
THL 10-03D1	
THL 10-04D1	

TL
Elbow



∅D T

MODEL [∅D-T]
Tube(Metric)-Thread(R)
TL 04-01
TL 04-02
TL 06-01
TL 06-02
TL 08-01
TL 08-02
TL 08-03
TL 10-02
TL 10-03
TL 12-03
TL 12-04

THT(D2)
Double Universal Tee



∅D T

MODEL [∅D-T]	
Tube(Metric)-Thread(R)	
THT 04-01D2	THT 12-02D2
THT 04-02D2	THT 12-03D2
THT 06-01D2	THT 12-04D2
THT 06-02D2	
THT 08-01D2	
THT 08-02D2	
THT 08-03D2	
THT 10-02D2	
THT 10-03D2	
THT 10-04D2	

THL(D2)
Double Universal Elbow



∅D T

MODEL [∅D-T]	
Tube(Metric)-Thread(R)	
THL 04-01D2	THL 12-02D2
THL 04-02D2	THL 12-03D2
THL 06-01D2	THL 12-04D2
THL 06-02D2	
THL 08-01D2	
THL 08-02D2	
THL 08-03D2	
THL 10-02D2	
THL 10-03D2	
THL 10-04D2	

TUT
Union Tee



∅D

MODEL [∅D]
Tube(Metric)
TUT 04
TUT 06
TUT 08
TUT 10
TUT 12

THT(D3)
Triple Universal Tee



∅D T

MODEL [∅D-T]	
Tube(Metric)-Thread(R)	
THT 04-01D3	THT 12-02D3
THT 04-02D3	THT 12-03D3
THT 06-01D3	THT 12-04D3
THT 06-02D3	
THT 08-01D3	
THT 08-02D3	
THT 08-03D3	
THT 10-02D3	
THT 10-03D3	
THT 10-04D3	

THL(D3)
Triple Universal Elbow



∅D T

MODEL [∅D-T]	
Tube(Metric)-Thread(R)	
THL 04-01D3	THL 12-02D3
THL 04-02D3	THL 12-03D3
THL 06-01D3	THL 12-04D3
THL 06-02D3	
THL 08-01D3	
THL 08-02D3	
THL 08-03D3	
THL 10-02D3	
THL 10-03D3	
THL 10-04D3	