

# Altivar Process

Variable Speed Drives ATV630, ATV650,  
ATV660

## Programming Manual

04/2015



---

The information provided in this documentation contains general descriptions and/or technical characteristics of the performance of the products contained herein. This documentation is not intended as a substitute for and is not to be used for determining suitability or reliability of these products for specific user applications. It is the duty of any such user or integrator to perform the appropriate and complete risk analysis, evaluation and testing of the products with respect to the relevant specific application or use thereof. Neither Schneider Electric nor any of its affiliates or subsidiaries shall be responsible or liable for misuse of the information contained herein. If you have any suggestions for improvements or amendments or have found errors in this publication, please notify us.

No part of this document may be reproduced in any form or by any means, electronic or mechanical, including photocopying, without express written permission of Schneider Electric.

All pertinent state, regional, and local safety regulations must be observed when installing and using this product. For reasons of safety and to help ensure compliance with documented system data, only the manufacturer should perform repairs to components.

When devices are used for applications with technical safety requirements, the relevant instructions must be followed.

Failure to use Schneider Electric software or approved software with our hardware products may result in injury, harm, or improper operating results.

Failure to observe this information can result in injury or equipment damage.

© 2015 Schneider Electric. All rights reserved.

# Table of Contents



	<b>Safety Information</b> .....	<b>15</b>
	<b>About the Book</b> .....	<b>19</b>
<b>Part I</b>	<b>Introduction</b> .....	<b>21</b>
<b>Chapter 1</b>	<b>Setup</b> .....	<b>23</b>
	Preliminary Recommendations .....	<b>24</b>
	Steps for Setting-Up the Drive .....	<b>26</b>
	Software Enhancements .....	<b>27</b>
<b>Chapter 2</b>	<b>Overview</b> .....	<b>29</b>
	Factory Configuration .....	<b>30</b>
	Application Functions .....	<b>31</b>
	Basic Functions .....	<b>33</b>
	Graphic Display Terminal .....	<b>34</b>
	Structure of the Parameter Table .....	<b>38</b>
	Finding a Parameter in This Document .....	<b>39</b>
<b>Part II</b>	<b>Programming</b> .....	<b>41</b>
<b>Chapter 3</b>	<b>[Simply start] S Y S -</b> .....	<b>43</b>
	[Simply start] S , П - Menu .....	<b>44</b>
	[My menu] П Y П n - Menu .....	<b>50</b>
	[Modified parameters] L П d - Menu .....	<b>51</b>
<b>Chapter 4</b>	<b>[Dashboard] d S H -</b> .....	<b>53</b>
	[Pump dashboard] P П E - Menu .....	<b>54</b>
	[Fan dashboard] F P n - Menu .....	<b>56</b>
	[Dashboard] d S H - Menu .....	<b>58</b>
	[Control] C E r - Menu .....	<b>59</b>
	[Control] F E r - Menu .....	<b>62</b>
	[Dashboard] d S H - Menu .....	<b>63</b>
	[Energy] K W C - Menu .....	<b>64</b>
	[Dashboard] d S H - Menu .....	<b>66</b>
<b>Chapter 5</b>	<b>[Diagnostics] d , R -</b> .....	<b>67</b>
5.1	[Diag. data] .....	<b>68</b>
	[Diag. data] d d E - Menu .....	<b>69</b>
	[Service message] S E r - Menu .....	<b>73</b>
	[Other State] S S E - Menu .....	<b>74</b>
	[Diagnostics] d R u - Menu .....	<b>75</b>
	[Identification] o , d - Menu .....	<b>76</b>
5.2	[Error history] .....	<b>77</b>
	[Error history] P F H - Menu .....	<b>77</b>
5.3	[Warnings] .....	<b>80</b>
	[Actual warnings] A L r d - Menu .....	<b>81</b>
	[Warning group 1 definition] A 1 C - Menu .....	<b>82</b>
	[Warning group 2 definition] A 2 C - Menu .....	<b>83</b>
	[Warning group 3 definition] A 3 C - Menu .....	<b>84</b>
	[Warning group 4 definition] A 4 C - Menu .....	<b>85</b>
	[Warning group 5 definition] A 5 C - Menu .....	<b>86</b>
	[Warnings] A L r - Menu .....	<b>87</b>

<b>Chapter 6</b>	<b>[Display] ПДП -</b>	<b>89</b>
6.1	[Energy parameters]	90
	[Elec Ener Input Counter] ELI - Menu	91
	[Elec Ener Output Counter] ELD - Menu	93
	[Mechanical energy] ПЕЛ - Menu	95
	[Energy saving] ЕСР - Menu	97
6.2	[Application parameters]	98
	[Application parameters] АРР - Menu	98
6.3	[Pump parameters]	101
	[Variable speed pump] ПРР - Menu	102
	[Multipump system] ПРС - Menu	104
6.4	[Motor parameters]	108
	[Motor parameters] ППО - Menu	108
6.5	[Drive parameters]	110
	[Drive parameters] ПР - Menu	110
6.6	[Thermal monitoring]	112
	[Thermal monitoring] ТРП - Menu	112
6.7	[PID display]	113
	[PID display] РЛ - Menu	113
6.8	[Counter management]	114
	[Counter Management] ЕЛТ - Menu	114
6.9	[Other state]	116
	[Other state] ССТ - Menu	116
6.10	[I/O map]	117
	[Digital Input Map] ЛРА - Menu	118
	[AI1] А1С - Menu	119
	[AI2] А2С - Menu	121
	[AI3] А3С - Menu	122
	[AI4] А4С - Menu	123
	[AI5] А5С - Menu	124
	[Digital output map] ЛРА - Menu	125
	[AQ1] АОС - Menu	126
	[AQ2] АОС - Menu	130
	[DI5 frequency measured] ПФС - Menu	131
	[DI6 frequency measured] ПФСБ - Menu	133
6.11	[Communication map]	134
	[Communication map] СПП - Menu	135
	[Modbus network diag] ППД - Menu	138
	[Com. scanner input map] СРА - Menu	139
	[Com scan output map] ОСРА - Menu	140
	[Modbus HMI Diag] ПДН - Menu	141
	[Ethernet Emb Diag] ПРЕ - Menu	142
	[Ethernet Module Diag] ПЛЕ - Menu	143
	[DeviceNet Diag] ДУП - Menu	144
	[Profibus Diag] РРБ - Menu	145
	[PROFINET Diag] РРН - Menu	147
	[Command word image] СШ - Menu	149
	[Freq. ref. word map] РШ - Menu	150
	[CANopen map] СНП - Menu	151
	[PDO1 image] ПО1 - Menu	152
	[PDO2 image] ПО2 - Menu	154
	[PDO3 image] ПО3 - Menu	155
	[CANopen map] СНП - Menu	156

6.12	[Data logging] .....	157
	[Distributed logging] <i>d L o</i> - Menu .....	158
	[Log dstrb prm select] <i>L d P</i> - Menu .....	159
	[Distributed logging] <i>d L o</i> - Menu .....	160
<b>Chapter 7</b>	<b>[Complete settings] <i>C S t</i> - .....</b>	<b>161</b>
7.1	Overview .....	163
	Application Control Mode .....	163
7.2	[Macro configuration] .....	166
	[Macro configuration] <i>Π C r</i> - Menu .....	166
7.3	[Motor parameters] .....	167
	[Motor parameters] <i>Π P R</i> - Menu .....	168
	[Data] <i>Π t d</i> - Menu .....	170
	[Motor tune] <i>Π t u</i> - Menu .....	177
	[Motor monitoring] <i>Π o P</i> - Menu .....	181
	[Pump thermal monit] <i>t P P</i> - Menu .....	182
	[Motor monitoring] <i>Π o P</i> - Menu .....	190
	[Motor control] <i>d r C</i> - Menu .....	192
	[Switching frequency] <i>S W F</i> - Menu .....	197
7.4	[Define system units] .....	199
	[Define system units] <i>S u C</i> - Menu .....	199
7.5	[Sensors assignment] .....	203
	[Sensors assignment] <i>S C C</i> - Menu .....	204
	[AI1 sensor config.] <i>, C R 1</i> - Menu .....	205
	[AI2 sensor config.] <i>, C R 2</i> - Menu .....	207
	[AI3 sensor config.] <i>, C R 3</i> - Menu .....	208
	[AI4 sensor config.] <i>, C R 4</i> - Menu .....	209
	[AI5 sensor config.] <i>, C R 5</i> - Menu .....	211
	[AIV1 sensor config.] <i>, C u 1</i> - Menu .....	212
	[Sensors assignment] <i>S C C</i> - Menu .....	213
	[AI1 sensor config.] <i>o C R 1</i> - Menu .....	214
	[AI2 sensor config.] <i>o C R 2</i> - Menu .....	216
	[AI3 sensor config.] <i>o C R 3</i> - Menu .....	217
	[AI4 sensor config.] <i>o C R 4</i> - Menu .....	218
	[AI5 sensor config.] <i>o C R 5</i> - Menu .....	219
	[AIV1 sensor config.] <i>o C u 1</i> - Menu .....	220
	[Sensors assignment] <i>S C C</i> - Menu .....	221
	[AI1 sensor config.] <i>, F 1</i> - Menu .....	222
	[AI2 sensor config.] <i>, F 2</i> - Menu .....	224
	[AI3 sensor config.] <i>, F 3</i> - Menu .....	225
	[AI4 sensor config.] <i>, F 4</i> - Menu .....	226
	[AI5 sensor config.] <i>, F 5</i> - Menu .....	227
	[DI5 Pulse Sensor Config.] <i>, F B</i> - Menu .....	228
	[DI6 Pulse Sensor Config.] <i>, F G</i> - Menu .....	229
	[AIV1 sensor config.] <i>, F V 1</i> - Menu .....	230
	[Sensors assignment] <i>S C C</i> - Menu .....	231
	[AI1 sensor config.] <i>P F 1</i> - Menu .....	232
	[AI2 sensor config.] <i>P F 2</i> - Menu .....	234
	[AI3 sensor config.] <i>P F 3</i> - Menu .....	236
	[AI4 sensor config.] <i>P F 4</i> - Menu .....	237
	[AI5 sensor config.] <i>P F 5</i> - Menu .....	239
	[DI5 configuration] <i>P F B</i> - Menu .....	240
	[DI6 configuration] <i>P F G</i> - Menu .....	241
	[AIV1 configuration] <i>P F V 1</i> - Menu .....	242
	[Sensors assignment] <i>S C C</i> - Menu .....	243
	[AI1 configuration] <i>L C R 1</i> - Menu .....	244

	[AI2 configuration] <i>L C A 2</i> - Menu .....	246
	[AI3 configuration] <i>L C A 3</i> - Menu .....	247
	[AI4 configuration] <i>L C A 4</i> - Menu .....	248
	[AI5 configuration] <i>L C A 5</i> - Menu .....	249
	[AIV1 configuration] <i>L C u 1</i> - Menu .....	250
7.6	[Command and Reference] .....	251
	[Command and Reference] <i>C r P</i> - Menu .....	251
7.7	[Pump functions] - [Booster control] .....	263
	[System Architecture] <i>Π P 9</i> - Menu .....	264
	[Pumps configuration] <i>P u Π P</i> - Menu .....	269
	[System Architecture] <i>Π P 9</i> - Menu .....	272
	[Booster control] <i>b 5 C</i> - Menu .....	273
	[Stage/Destage condition] <i>S d C Π</i> - Menu .....	274
	[Stage/Destage method] <i>S d Π Π</i> - Menu .....	276
	[Booster control] <i>b 5 C</i> - Menu .....	280
7.8	[Pump functions] - [Level control] .....	281
	[System architecture] <i>Π P 9</i> - Menu .....	282
	[Pumps configuration] <i>P u Π P</i> - Menu .....	283
	[Level control] <i>L c c</i> - Menu .....	284
	[AI1 configuration] <i>L C A 1</i> - Menu .....	289
	[AI2 configuration] <i>L C A 2</i> - Menu .....	291
	[AI3 configuration] <i>L C A 3</i> - Menu .....	292
	[AI4 configuration] <i>L C A 4</i> - Menu .....	293
	[AI5 configuration] <i>L C A 5</i> - Menu .....	294
	[AIV1 configuration] <i>L C u 1</i> - Menu .....	295
	[Level control] <i>L c c</i> - Menu .....	296
	[Level settings] <i>L c L</i> - Menu .....	299
7.9	[Pump functions] - [PID controller] .....	304
	[PID controller] <i>P , d</i> - Overview .....	305
	[Feedback] <i>F d b</i> - Menu .....	308
	[Reference frequency] <i>r F</i> - Menu .....	314
	[PID preset references] <i>P r ,</i> - Menu .....	317
	[Reference frequency] <i>r F</i> - Menu .....	319
	[Settings] <i>S t</i> - Menu .....	320
7.10	[Pump functions] - [Sleep/wakeup] .....	323
	[Sleep/Wakeup] <i>S P w</i> - Overview .....	324
	[Sleep menu] <i>S L P</i> - Menu .....	327
	[AI1 Sensor config.] <i>S , F 1</i> - Menu .....	329
	[AI2 Sensor config.] <i>S , F 2</i> - Menu .....	331
	[AI3 Sensor config.] <i>S , F 3</i> - Menu .....	333
	[AI4 Sensor config.] <i>S , F 4</i> - Menu .....	334
	[AI5 Sensor config.] <i>S , F 5</i> - Menu .....	336
	[DI5 Sensor Configuration] <i>S , F B</i> - Menu .....	337
	[DI6 Sensor Configuration] <i>S , F 9</i> - Menu .....	338
	[AIV1 Sensor config.] <i>S , V 1</i> - Menu .....	339
	[Sleep menu] <i>S L P</i> - Menu .....	340
	[AI1 Sensor config.] <i>S o A 1</i> - Menu .....	341
	[AI2 Sensor config.] <i>S o A 2</i> - Menu .....	343
	[AI3 Sensor config.] <i>S o A 3</i> - Menu .....	345
	[AI4 Sensor config.] <i>S o A 4</i> - Menu .....	346
	[AI5 Sensor config.] <i>S o A 5</i> - Menu .....	348
	[AIV1 Sensor config.] <i>S o V 1</i> - Menu .....	349
	[Sleep menu] <i>S L P</i> - Menu .....	350
	[Boost] <i>S b t</i> - Menu .....	351
	[Advanced sleep check] <i>R d S</i> - Menu .....	352

	[Wake up menu] <i>WKP</i> - Menu . . . . .	354
	[AI1 Sensor config.] <i>WAR1</i> - Menu . . . . .	355
	[AI2 Sensor config.] <i>WAR2</i> - Menu . . . . .	357
	[AI3 Sensor config.] <i>WAR3</i> - Menu . . . . .	359
	[AI4 Sensor config.] <i>WAR4</i> - Menu . . . . .	360
	[AI5 Sensor config.] <i>WAR5</i> - Menu . . . . .	362
	[AIV1 Sensor config.] <i>WAV1</i> - Menu . . . . .	363
	[Wake up menu] <i>WKP</i> - Menu . . . . .	364
7.11	[Pump functions] - [Feedback monitoring] . . . . .	365
	[Feedback monitoring] <i>FKP</i> - Menu . . . . .	365
7.12	[Pump functions] - [Pump characteristics] . . . . .	367
	[Pump characteristics] <i>PCR</i> - Menu . . . . .	367
7.13	[Pump functions] - [Sensorless flow estimation] . . . . .	375
	[Sensorless flow estimation] <i>SFE</i> - Menu . . . . .	375
7.14	[Pump functions] - [Pump start stop] . . . . .	378
	[Pump start stop] <i>PSE</i> - Menu . . . . .	378
7.15	[Pump functions] - [Pipe fill] . . . . .	382
	[Pipe fill] <i>PF1</i> - Menu . . . . .	383
	[AI1 configuration] <i>PFA1</i> - Menu . . . . .	385
	[AI2 configuration] <i>PFA2</i> - Menu . . . . .	387
	[AI3 configuration] <i>PFA3</i> - Menu . . . . .	389
	[AI4 configuration] <i>PFA4</i> - Menu . . . . .	390
	[AI5 configuration] <i>PFA5</i> - Menu . . . . .	392
	[AIV1 configuration] <i>PFAV1</i> - Menu . . . . .	393
	[Pipe fill] <i>PF1</i> - Menu . . . . .	394
7.16	[Pump functions] - [Friction loss compensation] . . . . .	396
	[Friction loss comp] <i>FLC</i> - Menu . . . . .	397
	[AI1 Installation Flow] <i>F1F1</i> - Menu . . . . .	398
	[AI2 Installation Flow] <i>F1F2</i> - Menu . . . . .	400
	[AI3 Installation Flow] <i>F1F3</i> - Menu . . . . .	401
	[AI4 Installation Flow] <i>F1F4</i> - Menu . . . . .	402
	[AI5 Installation Flow] <i>F1F5</i> - Menu . . . . .	404
	[PI5 Installation Flow] <i>F1FB</i> - Menu . . . . .	405
	[PI6 Installation Flow] <i>F1F9</i> - Menu . . . . .	406
	[AIV1 Installation flow] <i>F1FI</i> - Menu . . . . .	407
	[Friction loss comp] <i>FLC</i> - Menu . . . . .	408
7.17	[Pump functions] - [Jockey pump] . . . . .	409
	[Jockey pump] <i>JKP</i> - Menu . . . . .	409
7.18	[Pump functions] - [Priming pump ctrl] . . . . .	411
	[Priming pump ctrl] <i>PPC</i> - Menu . . . . .	412
	[AI1 configuration] <i>PPA1</i> - Menu . . . . .	415
	[AI2 configuration] <i>PPA2</i> - Menu . . . . .	417
	[AI3 configuration] <i>PPA3</i> - Menu . . . . .	418
	[AI4 configuration] <i>PPA4</i> - Menu . . . . .	419
	[AI5 configuration] <i>PPA5</i> - Menu . . . . .	420
	[AIV1 configuration] <i>PPAV1</i> - Menu . . . . .	421
	[Priming pump ctrl] <i>PPC</i> - Menu . . . . .	422
7.19	[Pump functions] - [Flow limitation] . . . . .	423
	[Flow limitation] <i>FLP</i> - Menu . . . . .	424
	[AI1 sensor config.] <i>LF1</i> - Menu . . . . .	426
	[AI2 sensor config.] <i>LF2</i> - Menu . . . . .	428
	[AI3 sensor config.] <i>LF3</i> - Menu . . . . .	429
	[AI4 sensor config.] <i>LF4</i> - Menu . . . . .	430
	[AI5 sensor config.] <i>LF5</i> - Menu . . . . .	432

	[DI5 Pulse Sensor Config.] <i>L F B</i> - Menu .....	433
	[DI6 Pulse Sensor Config.] <i>L F 9</i> - Menu .....	434
	[AIV1 Pulse sensor config.] <i>L F u I</i> - Menu .....	435
	[Flow limitation] <i>F L П</i> - Menu .....	436
7.20	[Pump monitoring] - [Pumpcycle monitoring] .....	437
	[Pumpcycle monitoring] <i>C 5 P</i> - Menu .....	437
7.21	[Pump monitoring] - [Anti jam] .....	439
	[Anti-jam monit] <i>J A П</i> - Menu .....	439
7.22	[Pump monitoring] - [Dry run] .....	445
	[Dry run Monit] <i>d Y r</i> - Menu .....	445
7.23	[Pump monitoring] - [Pump low flow Monit] .....	448
	[Pump low flow Monit] <i>P L F</i> - Menu .....	449
	[AI1 Sensor config.] <i>n P F 1</i> - Menu .....	451
	[AI2 Sensor config.] <i>n P F 2</i> - Menu .....	453
	[AI3 Sensor config.] <i>n P F 3</i> - Menu .....	455
	[AI4 Sensor config.] <i>n P F 4</i> - Menu .....	456
	[AI5 Sensor config.] <i>n P F 5</i> - Menu .....	458
	[DI5 Pulse Sensor Config] <i>n P F B</i> - Menu .....	459
	[DI6 Pulse Sensor Config] <i>n P F 9</i> - Menu .....	460
	[AIV1 Sensor config.] <i>n P V I</i> - Menu .....	461
	[Pump low flow Monit] <i>P L F</i> - Menu .....	462
7.24	[Pump monitoring] - [Pump thermal monit] .....	465
	[Pump thermal monit] <i>t P P</i> - Menu .....	465
7.25	[Pump monitoring] - [Inlet pressure monitori..] .....	473
	[Inlet pressure monitoring] <i>, P P</i> - Menu .....	474
	[AI1 sensor config.] <i>, P A 1</i> - Menu .....	476
	[AI2 sensor config.] <i>, P A 2</i> - Menu .....	478
	[AI3 sensor config.] <i>, P A 3</i> - Menu .....	480
	[AI4 sensor config.] <i>, P A 4</i> - Menu .....	481
	[AI5 sensor config.] <i>, P A 5</i> - Menu .....	483
	[AIV1 sensor config.] <i>, P u I</i> - Menu .....	484
	[Inlet pressure monitoring] <i>, P P</i> - Menu .....	485
7.26	[Pump monitoring] - [Outlet pressure monitoring] .....	486
	[Outlet pressure monitoring] <i>o P P</i> - Menu .....	487
	[AI1 Sensor config.] <i>o o A 1</i> - Menu .....	489
	[AI2 Sensor config.] <i>o o A 2</i> - Menu .....	491
	[AI3 Sensor config.] <i>o o A 3</i> - Menu .....	492
	[AI4 Sensor config.] <i>o o A 4</i> - Menu .....	493
	[AI5 Sensor config.] <i>o o A 5</i> - Menu .....	495
	[AIV1 Sensor config.] <i>o o u I</i> - Menu .....	496
	[Outlet pressure monito..] <i>o P P</i> - Menu .....	497
7.27	[Pump monitoring] - [High flow monitoring] .....	498
	[High flow monitoring] <i>H F P</i> - Menu .....	499
	[AI1 sensor config.] <i>H , F 1</i> - Menu .....	501
	[AI2 sensor config.] <i>H F , 2</i> - Menu .....	503
	[AI3 sensor config.] <i>H F , 3</i> - Menu .....	504
	[AI4 sensor config.] <i>H F , 4</i> - Menu .....	505
	[AI5 sensor config.] <i>H F , 5</i> - Menu .....	506
	[DI5 Pulse Sensor Config] <i>H , F B</i> - Menu .....	507
	[DI6 Pulse Sensor Config] <i>H , F 9</i> - Menu .....	508
	[AIV1 Sensor config.] <i>o o u I</i> - Menu .....	509
	[High flow monitoring] <i>H F P</i> - Menu .....	510



7.28	[Fan] - [PID controller] . . . . .	511
	[PID controller] <i>P i d</i> - Overview . . . . .	512
	[Feedback] <i>F d b</i> - Menu . . . . .	515
	[Reference frequency] <i>r F</i> - Menu . . . . .	521
	[PID preset references] <i>P r i</i> - Menu . . . . .	524
	[Reference frequency] <i>r F</i> - Menu . . . . .	526
	[Settings] <i>S t</i> - Menu . . . . .	527
7.29	[Fan] - [Feedback monitoring] . . . . .	530
	[Feedback monitoring] <i>F K n</i> - Menu . . . . .	530
7.30	[Fan] - [Jump frequency] . . . . .	531
	[Jump frequency] <i>J u F</i> - Menu . . . . .	531
7.31	[Fan] . . . . .	532
	[Fan] <i>C S F n</i> - Menu . . . . .	532
7.32	[Generic functions] - [Speed limits] . . . . .	534
	[Speed limits] <i>S L n</i> - Menu . . . . .	534
7.33	[Generic functions] - [Ramp] . . . . .	537
	[Ramp] <i>r n P P</i> - Menu . . . . .	537
7.34	[Generic functions] - [Ramp switching] . . . . .	540
	[Ramp switching] <i>r P t</i> - Menu . . . . .	540
7.35	[Generic functions] - [Stop configuration] . . . . .	542
	[Stop configuration] <i>S t t</i> - Menu . . . . .	542
7.36	[Generic functions] - [Auto DC injection] . . . . .	548
	[Auto DC injection] <i>A d C</i> - Menu . . . . .	548
7.37	[Generic functions] - [Ref. operations] . . . . .	551
	[Ref. operations] <i>a n i</i> - Menu . . . . .	551
7.38	[Generic functions] - [Preset speeds] . . . . .	553
	[Preset speeds] <i>P S S</i> - Menu . . . . .	553
7.39	[Generic functions] - [+/- speed] . . . . .	557
	[+/- speed] <i>u P d</i> - Menu . . . . .	557
7.40	[Generic functions] - [Jump frequency] . . . . .	560
	[Jump frequency] <i>J u F</i> - Menu . . . . .	560
7.41	[Generic functions] - [PID controller] . . . . .	561
	[PID controller] <i>P i d</i> - Overview . . . . .	562
	[Feedback] <i>F d b</i> - Menu . . . . .	565
	[Reference frequency] <i>r F</i> - Menu . . . . .	571
	[PID preset references] <i>P r i</i> - Menu . . . . .	574
	[Reference frequency] <i>r F</i> - Menu . . . . .	576
	[Settings] <i>S t</i> - Menu . . . . .	577
7.42	[Generic functions] - [Feedback mon.] . . . . .	580
	[Feedback monitoring] <i>F K n</i> - Menu . . . . .	580
7.43	[Generic functions] - [Threshold reached] . . . . .	581
	[Threshold reached] <i>t H r E</i> - Menu . . . . .	581
7.44	[Generic functions] - [Mains contactor command] . . . . .	583
	[Mains contactor command] <i>L L C</i> - Menu . . . . .	583
7.45	[Generic functions] - [Reverse disable] . . . . .	585
	[Reverse disable] <i>r E i n</i> - Menu . . . . .	585
7.46	[Generic functions] - [Torque limitation] . . . . .	586
	[Torque limitation] <i>t o L</i> - Menu . . . . .	586
7.47	[Generic functions] - [Parameters switching] . . . . .	588
	[Parameters switching] <i>n L P</i> - Menu . . . . .	589
	[Set 1] <i>P S 1</i> - Menu . . . . .	594
	[Set 2] <i>P S 2</i> - Menu . . . . .	595
	[Set 3] <i>P S 3</i> - Menu . . . . .	596
7.48	[Generic functions] - [Stop on prolonged spd] . . . . .	597
	[Stop after speed timeout] <i>P r S P</i> - Menu . . . . .	597

7.49	[Generic monitoring] . . . . .	599
	[Process underload] $\cup L d$ - Menu . . . . .	600
	[Process overload] $\square L d$ - Menu . . . . .	602
	[Stall monitoring] $5 \underline{L} P r$ - Menu . . . . .	604
	[Pump thermal monit] $\underline{L} P P$ - Menu . . . . .	605
7.50	[Input/Output] - [I/O assignment] . . . . .	606
	[DI1 assignment] $L 1 A$ - Menu . . . . .	607
	[DI2 assignment] $L 2 A$ - Menu . . . . .	609
	[DI3 assignment] $L 3 A$ - Menu . . . . .	610
	[DI4 assignment] $L 4 A$ - Menu . . . . .	611
	[DI5 assignment] $L 5 A$ - Menu . . . . .	612
	[DI6 assignment] $L 6 A$ - Menu . . . . .	613
	[DI11 assignment] $L 1 1 A$ - Menu . . . . .	614
	[DI12 assignment] $L 1 2 A$ - Menu . . . . .	615
	[DI13 assignment] $L 1 3 A$ - Menu . . . . .	616
	[DI14 assignment] $L 1 4 A$ - Menu . . . . .	617
	[DI15 assignment] $L 1 5 A$ - Menu . . . . .	618
	[DI16 assignment] $L 1 6 A$ - Menu . . . . .	619
	[DI5 Pulse Input Assign] $P , 5 A$ - Menu . . . . .	620
	[DI6 Pulse Input Assign] $P , 6 A$ - Menu . . . . .	621
	[A11 assignment] $A , 1 A$ - Menu . . . . .	622
	[A12 assignment] $A , 2 A$ - Menu . . . . .	623
	[A13 assignment] $A , 3 A$ - Menu . . . . .	624
	[A14 assignment] $A , 4 A$ - Menu . . . . .	625
	[A15 assignment] $A , 5 A$ - Menu . . . . .	626
	[AU1A assignment] $A \cup 1 A$ - Menu . . . . .	627
7.51	[Input/Output] - [DI/DQ] . . . . .	628
	[DI1 Configuration] $d , 1$ - Menu . . . . .	629
	[DI2 Configuration] $d , 2$ - Menu . . . . .	631
	[DI3 Configuration] $d , 3$ - Menu . . . . .	632
	[DI4 Configuration] $d , 4$ - Menu . . . . .	633
	[DI5 Configuration] $d , 5$ - Menu . . . . .	634
	[DI6 Configuration] $d , 6$ - Menu . . . . .	635
	[DI11 Configuration] $d , 1 1$ - Menu . . . . .	636
	[DI12 Configuration] $d , 1 2$ - Menu . . . . .	637
	[DI13 Configuration] $d , 1 3$ - Menu . . . . .	638
	[DI14 Configuration] $d , 1 4$ - Menu . . . . .	639
	[DI15 Configuration] $d , 1 5$ - Menu . . . . .	640
	[DI16 Configuration] $d , 1 6$ - Menu . . . . .	641
	[DI5 Pulse Config] $P A , 5$ - Menu . . . . .	642
	[DI6 Pulse Config] $P A , 6$ - Menu . . . . .	644
	[DQ11 Configuration] $d \square 1 1$ - Menu . . . . .	645
	[DQ12 Configuration] $d \square 1 2$ - Menu . . . . .	647
7.52	[Input/Output] - [Analog I/O] . . . . .	648
	[A11 configuration] $A , 1$ - Menu . . . . .	649
	[A12 configuration] $A , 2$ - Menu . . . . .	652
	[A13 configuration] $A , 3$ - Menu . . . . .	654
	[A14 configuration] $A , 4$ - Menu . . . . .	655
	[A15 configuration] $A , 5$ - Menu . . . . .	657
	[AQ1 configuration] $A \square 1$ - Menu . . . . .	658
	[AQ2 configuration] $A \square 2$ - Menu . . . . .	662
	[Virtual AI1] $A \cup 1$ - Menu . . . . .	664

7.53	[Input/Output] - [Relay] . . . . .	665
	[R1 configuration] <i>r 1</i> - Menu . . . . .	666
	[R2 configuration] <i>r 2</i> - Menu . . . . .	668
	[R3 configuration] <i>r 3</i> - Menu . . . . .	669
	[R4 configuration] <i>r 4</i> - Menu . . . . .	670
	[R5 configuration] <i>r 5</i> - Menu . . . . .	671
	[R6 configuration] <i>r 6</i> - Menu . . . . .	672
7.54	[Error/Warning handling] . . . . .	673
	[Auto fault reset] <i>A E r</i> - Menu . . . . .	674
	[Fault reset] <i>r 5 E</i> - Menu . . . . .	675
	[Catch on the fly] <i>F L r</i> - Menu . . . . .	677
	[Error detection disable] <i>i n H</i> - Menu . . . . .	678
	[External error] <i>E E F</i> - Menu . . . . .	679
	[Output phase loss] <i>o P L</i> - Menu . . . . .	681
	[Input phase loss] <i>i P L</i> - Menu . . . . .	682
	[4-20mA loss] <i>L F L</i> - Menu . . . . .	683
	[Fallback speed] <i>L F F</i> - Menu . . . . .	684
	[Fieldbus monitoring] <i>C L L</i> - Menu . . . . .	685
	[Embedded Modbus TCP] <i>E n E C</i> - Menu . . . . .	686
	[Communication module] <i>C o n o</i> - Menu . . . . .	687
	[Undervoltage handling] <i>u 5 b</i> - Menu . . . . .	689
	[Ground Fault] <i>G r F L</i> - Menu . . . . .	691
	[Warn grp 1 definition] <i>A 1 C</i> - Menu . . . . .	692
	[Warn grp 2 definition] <i>A 2 C</i> - Menu . . . . .	694
	[Warn grp 3 definition] <i>A 3 C</i> - Menu . . . . .	695
	[Warn grp 4 definition] <i>A 4 C</i> - Menu . . . . .	696
	[Warn grp 5 definition] <i>A 5 C</i> - Menu . . . . .	697
7.55	[Maintenance] . . . . .	698
	[Diagnostics] <i>d A u</i> - Menu . . . . .	699
	[Drive warranty mgnt] <i>d W n A</i> - Menu . . . . .	700
	[Customer event 1] <i>C E 1</i> - Menu . . . . .	701
	[Customer event 2] <i>C E 2</i> - Menu . . . . .	702
	[Customer event 3] <i>C E 3</i> - Menu . . . . .	703
	[Customer event 4] <i>C E 4</i> - Menu . . . . .	704
	[Customer event 5] <i>C E 5</i> - Menu . . . . .	705
	[Customer events] <i>C u E v</i> - Menu . . . . .	706
	[Fan management] <i>F A n A</i> - Menu . . . . .	707
	[Maintenance] <i>C 5 n A</i> - Menu . . . . .	708
<b>Chapter 8</b>	<b>[Communication] <i>C o n</i> - . . . . .</b>	<b>709</b>
	[Modbus Fieldbus] <i>n d 1</i> - Menu . . . . .	710
	[Com. scanner input] <i>i, C 5</i> - Menu . . . . .	712
	[Com. scanner output] <i>o C 5</i> - Menu . . . . .	713
	[Modbus HMI] <i>n d 2</i> - Menu . . . . .	714
	[Embd Eth Config] <i>E E E</i> - Menu . . . . .	715
	[Eth Module Config] <i>E E o</i> - Menu . . . . .	716
	[CANopen] <i>C n o</i> - Menu . . . . .	717
	[DeviceNet] <i>d n C</i> - Menu . . . . .	718
	[Profibus] <i>P b C</i> - Menu . . . . .	719
	[Profinet] <i>P n C</i> - Menu . . . . .	720
	[Communication] <i>C o n</i> - Menu . . . . .	721
<b>Chapter 9</b>	<b>[File management] <i>F n E</i> - . . . . .</b>	<b>723</b>
	[Transfer config file] <i>E C F</i> - Menu . . . . .	724
	[Factory settings] <i>F C 5</i> - Menu . . . . .	725
	[Parameter group list] <i>F r Y</i> - Menu . . . . .	726
	[Factory settings] <i>F C 5</i> - Menu . . . . .	727

<b>Chapter 10</b>	<b>[My preferences] ПУР -</b>	<b>729</b>
10.1	[Language]	730
	[Language] ЛНГ - Menu	730
10.2	[Password]	731
	[Password] Цод - Menu	731
10.3	[Parameter access]	732
	[Restricted channels] РЦд - Menu	733
	[Restricted param] РРР - Menu	734
	[Visibility] В, S - Menu	735
10.4	[Customization]	736
	[My menu config.] ПУС - Menu	737
	[Display screen type] П5С - Menu	738
	[Param. Bar Select] РБ5 - Menu	739
	[Customer parameters] ЦУР - Menu	740
	[Service message] СЕР - Menu	741
10.5	[Date & Time settings]	742
	[Date/time settings] РТС - Menu	742
10.6	[Access level]	743
	[Access level] ЛАС - Menu	743
10.7	[Webserver]	744
	[Webserver] WB5 - Menu	744
10.8	[Functions key mgnt]	745
	[Functions key mgnt] FКГ - Menu	745
10.9	[LCD settings]	746
	[LCD settings] ЦНЛ - Menu	746
10.10	[Stop and go]	747
	[Stop and go] СТГ - Menu	747
10.11	[QR code]	748
	[QR code] QRС - Menu	748
10.12	[QR code] - [My link 1]	749
	[My link 1] ПУЛ 1 - Menu	749
10.13	[QR code] - [My link 2]	750
	[My link 2] ПУЛ 2 - Menu	750
10.14	[QR code] - [My link 3]	751
	[My link 3] ПУЛ 3 - Menu	751
10.15	[QR code] - [My link 4]	752
	[My link 4] ПУЛ 4 - Menu	752
10.16	[Pairing password]	753
	[Pairing password] РР, .	753
<b>Part III</b>	<b>Maintenance and diagnostics.</b>	<b>755</b>
<b>Chapter 11</b>	<b>Maintenance</b>	<b>757</b>
	Maintenance.	757
<b>Chapter 12</b>	<b>Diagnostics and Troubleshooting</b>	<b>759</b>
12.1	Warning Codes	760
	Warning Codes	760
12.2	Error Codes	762
	Overview	764
	[Angle error] А5F	765
	[Incorrect Configuration] ЦFF	766
	[Invalid Configuration] ЦF, .	767
	[Conf Transfer Error] ЦF, 2	768
	[Fieldbus Com Interrupt] ЦНF	769
	[CANopen Com Interrupt] ЦоF	770
	[Precharge Capacitor] ЦрF	771
	[Channel Switch Error] Ц5F	772

[Dry Run Error] <i>dr YF</i> .....	773
[EEPROM Control] <i>EEF I</i> .....	774
[EEPROM Power] <i>EEF 2</i> .....	775
[External Error] <i>EPF I</i> .....	776
[Fieldbus Error] <i>EPF 2</i> .....	777
[Embd Eth Com Interrupt] <i>E E HF</i> .....	778
[Boards Compatibility] <i>HCF</i> .....	779
[High Flow Error] <i>HFPF</i> .....	780
[Internal Link Error] <i>ILF</i> .....	781
[Internal Error 0] <i>INF 0</i> .....	782
[Internal Error 1] <i>INF I</i> .....	783
[Internal Error 2] <i>INF 2</i> .....	784
[Internal Error 3] <i>INF 3</i> .....	785
[Internal Error 4] <i>INF 4</i> .....	786
[Internal Error 6] <i>INF 6</i> .....	787
[Internal Error 7] <i>INF 7</i> .....	788
[Internal Error 8] <i>INF 8</i> .....	789
[Internal Error 9] <i>INF 9</i> .....	790
[Internal Error 10] <i>INF A</i> .....	791
[Internal Error 11] <i>INF b</i> .....	792
[Internal Error 12] <i>INF C</i> .....	793
[Internal Error 13] <i>INF d</i> .....	794
[Internal Error 14] <i>INF E</i> .....	795
[Internal Error 15] <i>INF F</i> .....	796
[Internal Error 16] <i>INF G</i> .....	797
[Internal Error 17] <i>INF h</i> .....	798
[Internal Error 18] <i>INF i</i> .....	799
[Internal Error 20] <i>INF K</i> .....	800
[Internal Error 21] <i>INF L</i> .....	801
[Internal Error 25] <i>INF P</i> .....	802
[Internal Error 27] <i>INF r</i> .....	803
[Internal Error 30] <i>INF w</i> .....	804
[Inlet Pressure Error] <i>IPPF</i> .....	805
[Anti Jam Error] <i>JAPF</i> .....	806
[Input Contactor] <i>LCF</i> .....	807
[High Level Error] <i>LCHF</i> .....	808
[High Level Error] <i>LCLF</i> .....	809
[AI1 4-20mA loss] <i>LIFF I</i> .....	810
[AI2 4-20mA loss] <i>LIFF 2</i> .....	811
[AI3 4-20mA loss] <i>LIFF 3</i> .....	812
[AI4 4-20mA loss] <i>LIFF 4</i> .....	813
[AI5 4-20mA loss] <i>LIFF 5</i> .....	814
[Lead Pump Error] <i>PLPF</i> .....	815
[DC Bus Overvoltage] <i>o b F</i> .....	816
[Overcurrent] <i>o C F</i> .....	817
[Drive Overheating] <i>o HF</i> .....	818
[Process Overload] <i>o L C</i> .....	819
[Motor Overload] <i>o L F</i> .....	820
[Single Output Phase Loss] <i>o PF I</i> .....	821
[Output Phase Loss] <i>o PF 2</i> .....	822
[Out Pressure High] <i>o PHF</i> .....	823
[Out Pressure Low] <i>o PLF</i> .....	824
[Supply Mains Overvoltage] <i>o SF</i> .....	825
[PumpCycle Start Error] <i>PCPF</i> .....	826
[PID Feedback Error] <i>PF PF</i> .....	827

	[Program Loading Error] <i>PGLF</i> .....	828
	[Program Running Error] <i>PGrF</i> .....	829
	[Input phase loss] <i>PHF</i> .....	830
	[Pump Low Flow Error] <i>PLFF</i> .....	831
	[Safety Function Error] <i>SFFF</i> .....	832
	[Motor short circuit] <i>SCF1</i> .....	833
	[Ground Short Circuit] <i>SCF3</i> .....	834
	[IGBT Short Circuit] <i>SCF4</i> .....	835
	[Motor Short Circuit] <i>SCF5</i> .....	836
	[Modbus Com Interruption] <i>SLF1</i> .....	837
	[PC Com Interruption] <i>SLF2</i> .....	838
	[HMI Com Interruption] <i>SLF3</i> .....	839
	[Motor Overspeed] <i>SoF</i> .....	840
	[Motor Stall Error] <i>StF</i> .....	841
	[AI2 Thermal Sensor Error] <i>t2CF</i> .....	842
	[AI3 Thermal Sensor Error] <i>t3CF</i> .....	843
	[AI4 Thermal Sensor Error] <i>t4CF</i> .....	844
	[AI5 Thermal Sensor Error] <i>t5CF</i> .....	845
	[AI2 Th Error Level] <i>tH2F</i> .....	846
	[AI3 Th Error Level] <i>tH3F</i> .....	847
	[AI4 Th Error Level] <i>tH4F</i> .....	848
	[AI5 Th Error Level] <i>tH5F</i> .....	849
	[IGBT Overheating] <i>tJF</i> .....	850
	[Autotuning Error] <i>t n F</i> .....	851
	[Process Underload] <i>uLF</i> .....	852
	[Supply Mains UnderV] <i>uSF</i> .....	853
12.3	FAQ .....	854
	FAQ .....	854



## Important Information

### NOTICE

Read these instructions carefully, and look at the equipment to become familiar with the device before trying to install, operate, or maintain it. The following special messages may appear throughout this documentation or on the equipment to warn of potential hazards or to call attention to information that clarifies or simplifies a procedure.



The addition of this symbol to a “Danger” or “Warning” safety label indicates that an electrical hazard exists which will result in personal injury if the instructions are not followed.



This is the safety alert symbol. It is used to alert you to potential personal injury hazards. Obey all safety messages that follow this symbol to avoid possible injury or death.

### **DANGER**

**DANGER** indicates a hazardous situation which, if not avoided, **will result in death or serious injury**.

### **WARNING**

**WARNING** indicates a hazardous situation which, if not avoided, **could result in death or serious injury**.

### **CAUTION**

**CAUTION** indicates a hazardous situation which, if not avoided, **could result in minor or moderate injury**.

### **NOTICE**

**NOTICE** is used to address practices not related to physical injury.

### PLEASE NOTE

Electrical equipment should be installed, operated, serviced, and maintained only by qualified personnel. No responsibility is assumed by Schneider Electric for any consequences arising out of the use of this material.

A qualified person is one who has skills and knowledge related to the construction and operation of electrical equipment and its installation, and has received safety training to recognize and avoid the hazards involved.

### Qualification Of Personnel

Only appropriately trained persons who are familiar with and understand the contents of this manual and all other pertinent product documentation are authorized to work on and with this product. In addition, these persons must have received safety training to recognize and avoid hazards involved. These persons must have sufficient technical training, knowledge and experience and be able to foresee and detect potential hazards that may be caused by using the product, by changing the settings and by the mechanical, electrical and electronic equipment of the entire system in which the product is used. All persons working on and with the product must be fully familiar with all applicable standards, directives, and accident prevention regulations when performing such work.

## Intended Use

This product is a drive for three-phase synchronous and asynchronous motors and intended for industrial use according to this manual. The product may only be used in compliance with all applicable safety regulations and directives, the specified requirements and the technical data. Prior to using the product, you must perform a risk assessment in view of the planned application. Based on the results, the appropriate safety measures must be implemented. Since the product is used as a component in an entire system, you must ensure the safety of persons by means of the design of this entire system (for example, machine design). Any use other than the use explicitly permitted is prohibited and can result in hazards. Electrical equipment should be installed, operated, serviced, and maintained only by qualified personnel.

## Product Related Information

**Read and understand these instructions before performing any procedure with this drive.**

### **DANGER**

#### **HAZARD OF ELECTRIC SHOCK, EXPLOSION OR ARC FLASH**

- Only appropriately trained persons who are familiar with and understand the contents of this manual and all other pertinent product documentation and who have received safety training to recognize and avoid hazards involved are authorized to work on and with this drive system. Installation, adjustment, repair and maintenance must be performed by qualified personnel.
- The system integrator is responsible for compliance with all local and national electrical code requirements as well as all other applicable regulations with respect to grounding of all equipment.
- Many components of the product, including the printed circuit boards, operate with mains voltage. Do not touch. Use only electrically insulated tools.
- Do not touch unshielded components or terminals with voltage present.
- Motors can generate voltage when the shaft is rotated. Prior to performing any type of work on the drive system, block the motor shaft to prevent rotation.
- AC voltage can couple voltage to unused conductors in the motor cable. Insulate both ends of unused conductors of the motor cable.
- Do not short across the DC bus terminals or the DC bus capacitors or the braking resistor terminals.
- Before performing work on the drive system:
  - Disconnect all power, including external control power that may be present.
  - Place a **Do Not Turn On** label on all power switches.
  - Lock all power switches in the open position.
  - Wait 15 minutes to allow the DC bus capacitors to discharge. The DC bus LED is not an indicator of the absence of DC bus voltage that can exceed 800 Vdc. Measure the voltage on the DC bus between the DC bus terminals (PA/+, PC/-) using a properly rated voltmeter to verify that the voltage is <42 Vdc
  - If the DC bus capacitors do not discharge properly, contact your local Schneider Electric representative. Do not repair or operate the product.
- Install and close all covers before applying voltage.

**Failure to follow these instructions will result in death or serious injury.**

### **WARNING**

#### **UNEXPECTED MOVEMENT**

Drive systems may perform unexpected movements because of incorrect wiring, incorrect settings, incorrect data or other errors.

- Carefully install the wiring in accordance with the EMC requirements.
- Do not operate the product with unknown or unsuitable settings or data.
- Perform a comprehensive commissioning test.

**Failure to follow these instructions can result in death, serious injury, or equipment damage.**

Damaged products or accessories may cause electric shock or unanticipated equipment operation.



## DANGER

### ELECTRIC SHOCK OR UNANTICIPATED EQUIPMENT OPERATION

Do not use damaged products or accessories.

**Failure to follow these instructions will result in death or serious injury.**

Contact your local Schneider Electric sales office if you detect any damage whatsoever.

## WARNING

### LOSS OF CONTROL

- The designer of any control scheme must consider the potential failure modes of control paths and, for critical control functions, provide a means to achieve a safe state during and after a path failure. Examples of critical control functions are emergency stop, overtravel stop, power outage and restart.
- Separate or redundant control paths must be provided for critical control functions.
- System control paths may include communication links. Consideration must be given to the implications of unanticipated transmission delays or failures of the link.
- Observe all accident prevention regulations and local safety guidelines (1).
- Each implementation of the product must be individually and thoroughly tested for proper operation before being placed into service.

**Failure to follow these instructions can result in death, serious injury, or equipment damage.**

(1) For USA: Additional information, refer to NEMA ICS 1.1 (latest edition), Safety Guidelines for the Application, Installation, and Maintenance of Solid State Control and to NEMA ICS 7.1 (latest edition), Safety Standards for Construction and Guide for Selection, Installation and Operation of Adjustable-Speed Drive Systems.

## NOTICE

### DESTRUCTION DUE TO INCORRECT MAINS VOLTAGE

Before switching on and configuring the product, verify that it is approved for the mains voltage

**Failure to follow these instructions can result in equipment damage.**

The metal surfaces of the product may exceed 100 °C (212 °F) during operation.

## WARNING

### HOT SURFACES

- Ensure that any contact with hot surfaces is avoided.
- Do not allow flammable or heat-sensitive parts in the immediate vicinity of hot surfaces.
- Verify that the heat dissipation is sufficient by performing a test run under maximum load conditions.

**Failure to follow these instructions can result in death, serious injury, or equipment damage.**



---

# About the Book

---



## At a Glance

### Document Scope

The purpose of this document is to:

- help you to set up the drive,
- show you how to program the drive,
- show you the different menus, modes, and parameters,
- help you in maintenance and diagnostics.

### Validity Note

This documentation is valid for the Altivar Process drives.

The technical characteristics of the devices described in this document also appear online. To access this information online:

Step	Action
1	Go to the Schneider Electric home page <a href="http://www.schneider-electric.com">www.schneider-electric.com</a> .
2	In the <b>Search</b> box type the reference of a product or the name of a product range. <ul style="list-style-type: none"><li>● Do not include blank spaces in the reference or product range.</li><li>● To get information on grouping similar modules, use asterisks (*).</li></ul>
3	If you entered a reference, go to the <b>Product Datasheets</b> search results and click on the reference that interests you. If you entered the name of a product range, go to the <b>Product Ranges</b> search results and click on the product range that interests you.
4	If more than one reference appears in the <b>Products</b> search results, click on the reference that interests you.
5	Depending on the size of your screen, you may need to scroll down to see the data sheet.
6	To save or print a data sheet as a .pdf file, click <b>Download XXX product datasheet</b> .

The characteristics that are presented in this manual should be the same as those characteristics that appear online. In line with our policy of constant improvement, we may revise content over time to improve clarity and accuracy. If you see a difference between the manual and online information, use the online information as your reference.

## Related Documents

Use your tablet or your PC to quickly access detailed and comprehensive information on all our products on [www.schneider-electric.com](http://www.schneider-electric.com).

The internet site provides the information you need for products and solutions:

- The whole catalog for detailed characteristics and selection guides,
- The CAD files to help design your installation, available in over 20 different file formats,
- All software and firmware to maintain your installation up to date,
- A large quantity of White Papers, Environment documents, Application solutions, Specifications... to gain a better understanding of our electrical systems and equipment or automation,
- And finally all the User Guides related to your drive, listed below:

Title of Documentation	Reference Number
Altivar Process Getting Started	EAV63253
Altivar Process Installation Manual	EAV64301
Altivar Process Modbus Serial Link Manual (Embedded)	EAV64325
Altivar Process Ethernet Manual (Embedded)	EAV64327
Altivar Process Ethernet-IP - Modbus TCP Manual (VW3A3720)	EAV64328
Altivar Process ProfibusDP manual (VW3A3607)	EAV64329
Altivar Process DeviceNet manual (VW3A3609)	EAV64330
Altivar Process PROFINET manual (VW3A3627)	EAV64333
Altivar Process CANopen Serial Link Manual (VW3A3608, 618, 628)	EAV64331
Altivar Process Communication Parameters	EAV64332
Altivar Process Safety Function manual	EAV64334

You can download these technical publications and other technical information from our website at [www.schneider-electric.com](http://www.schneider-electric.com).

## Standards and Terminology

The technical terms, terminology, and the corresponding descriptions in this manual normally use the terms or definitions in the relevant standards.

In the area of drive systems this includes, but is not limited to, terms such as **error, error message, failure, fault, fault reset, protection, safe state, safety function, warning, warning message**, and so on.

Among others, these standards include:

- IEC 61800 series: Adjustable speed electrical power drive systems
- IEC 61508 Ed.2 series: Functional safety of electrical/electronic/programmable electronic safety-related
- EN 954-1 Safety of machinery - Safety related parts of control systems
- EN ISO 13849-1 & 2 Safety of machinery - Safety related parts of control systems.
- IEC 61158 series: Industrial communication networks - Fieldbus specifications
- IEC 61784 series: Industrial communication networks - Profiles
- IEC 60204-1: Safety of machinery - Electrical equipment of machines – Part 1: General requirements

---

# Part I

## Introduction

---

### What Is in This Part?

This part contains the following chapters:

Chapter	Chapter Name	Page
1	Setup	23
2	Overview	29



---

# Chapter 1

## Setup

---

### What Is in This Chapter?

This chapter contains the following topics:

Topic	Page
Preliminary Recommendations	24
Steps for Setting-Up the Drive	26
Software Enhancements	27

## Preliminary Recommendations

### Before Powering up the Drive

#### **WARNING**

##### **UNANTICIPATED EQUIPMENT OPERATION**

Verify that all digital inputs are inactive to avoid any unanticipated operation.

**Failure to follow these instructions can result in death, serious injury, or equipment damage.**

#### **WARNING**

##### **UNEXPECTED MOVEMENT**

Drive systems may perform unexpected movements because of incorrect wiring, incorrect settings, incorrect data or other errors.

- Carefully install the wiring in accordance with the EMC requirements.
- Do not operate the product with unknown or unsuitable settings or data.
- Perform a comprehensive commissioning test.

**Failure to follow these instructions can result in death, serious injury, or equipment damage.**

#### **CAUTION**

##### **RISK OF DERATED PERFORMANCE DUE TO CAPACITOR AGING**

The product capacitor performances after a long time storage above 2 years can be degraded. In that case, before using the product, apply the following procedure:

- Use a variable AC supply connected between L1 and L2
- Increase AC supply voltage to have:
  - 80% of rated voltage during 30 min
  - 100% of rated voltage for another 30 min

**Failure to follow these instructions can result in injury or equipment damage.**

### Start-up

#### **NOTE:**

If a Run command such as Run forward, Run reverse, DC injection is still active during:

- A product reset to the factory settings,
- A manual "Fault Reset" using **[Fault Reset Assign]**  $r 5 F$ ,
- A manual "Fault reset" by applying a product switched off and on again,
- A stop command given by a channel that is not the active channel command (such as Stop key of the display terminal in 2/3 wires control),

The drive is in a blocking state and displays **[Freewheel Stop]**  $r 5 E$ . It will be necessary to deactivate all active Run commands prior to authorizing a new Run command.

### Mains Contactor

#### **NOTICE**

##### **RISK OF DAMAGE TO THE DRIVE**

Mains contactor must not be activated with a cycle shorter than 60 s.

**Failure to follow these instructions can result in equipment damage.**



### Using a Motor with a Lower Rating or Dispensing with a Motor Altogether

In factory settings, the motor output phase loss detection is active: **[OutPhaseLoss Assign] 0 P L** is set to **[OPF Error Triggered] 5 E 5**. For details, refer to the parameter description ([see page 681](#)). For commissioning tests or maintenance phase, the drive could be connected to a small motor power size and thus trigger an error **[Output Phase Loss] 0 P L 2** or **[Single output phase loss] 0 P F 1** when a Run command is applied. For that purpose, the function can be disabled by setting **[OutPhaseLossAssign] 0 P L** to **[Function Inactive] n 0**.

Set also **[Motor control type] C E E** to **[U/F VC Standard] 5 E d** in **[Motor parameters] P P A -**. For details, refer to the parameter description ([see page 192](#)).

## NOTICE

### MOTOR OVERHEATING

External thermal monitoring against overloads is required under the following circumstances:

- If a motor with a nominal current of less than 20% of the nominal current of the drive is connected.
- If using Motor Switching function

**Failure to follow these instructions can result in equipment damage.**

## DANGER

### HAZARD OF ELECTRIC SHOCK, EXPLOSION OR ARC FLASH

If output phase monitoring is disabled, phase loss and, by implication, accidental disconnection of cables, are not detected.

- Verify that the setting of this parameter does not result in unsafe conditions.

**Failure to follow these instructions will result in death or serious injury.**

## Steps for Setting-Up the Drive



The image shows a Schneider Altivar Process drive unit, a black industrial device with a green control panel on the front. The control panel features a small LCD screen and several physical buttons. The Schneider logo and 'Altivar Process' branding are visible on the front panel.

- ① **INSTALLATION**  
Refer to the installation manual.
- ② **Switch On the drive without active run command.**
- ③ **Configure:**
  - The nominal frequency of the motor **[Motor Standard] b F r** if this is not 50 Hz.
  - The motor parameters including **[Motor Th Current] i t H** in the **[Motor parameters] Π P R** - menu, only if the factory configuration of the drive is not suitable.
  - The application functions in the **[Complete settings] L s t** - menu, only if the factory configuration of the drive is not suitable.
- ④ **In the [Pump start stop] P S t - menu, adjust the following parameters:**
  - [Acceleration] A C C** and **[Deceleration] d E C**
  - [Low speed] L S P** and **[High Speed] H S P**
- ⑤ **Start the drive.**

### Tips

Use the **[Config. Source] F C S** parameter (see page 725) to restore the factory settings at any time.

**NOTE:** The following operations must be performed for optimum drive performance in terms of accuracy and response time:

- Enter the values indicated on the motor nameplate in the **[Motor parameters] Π P R** - menu.
- Perform autotuning with the motor cold and connected using the **[Autotuning] t u n** parameter.

## Software Enhancements

### Overview

Since the Altivar Process was first launched, it has benefited from the addition of several new functions. The software version has been updated to V1.3.

Although this documentation relates to version V1.3, it can still be used with earlier versions.

### Enhancements Made to Version V1.2 in Comparison to V1.1

Factory setting		Enhancements
[Output Short Circuit Test] <i>S t r t</i>		This function is now enabled in factory configuration and is accessible in the <b>[Motor monitoring]</b> <i>Π o P</i> - menu
Menu	Parameter	Enhancements
[Motor parameters] <i>Π P A</i> -	[Motor Control Type] <i>C t t</i>	[SYN_U VC] <i>S Y n u</i> : motor control type specific for permanent magnet synchronous motors
[Sleep/Wakeup] <i>S P W</i> -	[Sleep Detect Mode] <i>S L P Π</i>	Replacement of [Sensor] <i>S n S r</i> : system enters in sleep mode on sensor condition by: <ul style="list-style-type: none"> <li>• [Flow] <i>L F</i>: system enters in sleep mode on low flow</li> <li>• [Pressure] <i>H P</i>: system enters in sleep mode on high pressure</li> <li>• [Multiple] <i>o r</i>: system enters in sleep mode on multiple-OR condition</li> </ul> Addition of possible pressure sensor assignment and configuration for sleep function: <ul style="list-style-type: none"> <li>• [Alx Sensor config.] <i>S o A X</i> -</li> <li>• [AIV1 Sensor config.] <i>S o V I</i> -</li> <li>• [Sleep Pressure Level] <i>S L P L</i></li> </ul>
	[Wake Up Mode] <i>W u P Π</i>	Addition of [Pressure] <i>L P</i> : wake up on low-pressure condition Addition of possible pressure sensor assignment and configuration for wake-up function: <ul style="list-style-type: none"> <li>• [Alx Sensor config.] <i>W o A X</i> -</li> <li>• [AIV1 Sensor config.] <i>W o V I</i> -</li> <li>• [Wake Up Press Level] <i>W u P L</i></li> </ul>
[Pipe fill] <i>P F i</i> -	[Pipe Fill on Wake Up] <i>P F W u</i>	New parameter
[Counter Management] <i>E L t</i> -	[Fan operation Time] <i>F c P t</i>	Replacement by [Fan operation Time] <i>F P b t</i> (32 bits)
[Data] <i>Π t d</i> -	[% error EMF sync] <i>r d R E</i>	This parameter is now accessible with the Graphic Display Terminal

### Enhancements Made to Version V1.3 in Comparison to V1.2

In the **[Dashboard]** *d S H* - menu, the content of the tabs is improved for pumps and fan applications.

In the **[Complete settings]** *C S t* - menu, the **[Macro Configuration]** *Π C r* - submenu is added with the **[Application Selection]** *A P P t* parameter. It allows to hide unnecessary parameters according to the selected application type.

In the **[Pump functions]** *P F t* - menu, **[Booster Control]** *b S t* - and **[Level Control]** *L u L* - functions are available, including their related parameters and the settings for multi-pump architecture.

A new possible setting **[Rotational Current Injection]** *r C i* is added for synchronous motor **[Angle setting type]** *A S t*.

Up to 4 QR codes customizable with the commissioning software are displayed in **[QR code]** *q r C* - menu.



---

# Chapter 2

## Overview

---

### What Is in This Chapter?

This chapter contains the following topics:

Topic	Page
Factory Configuration	30
Application Functions	31
Basic Functions	33
Graphic Display Terminal	34
Structure of the Parameter Table	38
Finding a Parameter in This Document	39

## Factory Configuration

### Factory Settings

The drive is factory-set for common operating conditions:

- Display: drive ready **[Ref Frequency]** *L F r* when motor is ready to run and motor frequency when motor is running.
- The DI2 to DI6 digital inputs, AI2 and AI3 analog inputs, R2 and R3 relays are unassigned.
- Stop mode when error detected: freewheel.
- Reverse direction is disabled.

This table presents the basic parameters of the drive and their factory setting values:

Code	Name	Factory Setting Values
<i>b F r</i>	<b>[Motor Standard]</b>	<b>[50Hz IEC]</b> <i>S D</i>
<i>r i n</i>	<b>[Reverse Disable]</b>	<b>[Yes]</b> <i>Y E S</i>
<i>t c c</i>	<b>[2/3-Wire Control]</b>	<b>[2-Wire Control]</b> <i>2 C</i> : 2-wire control
<i>l t t</i>	<b>[Motor control type]</b>	<b>[U/F VC Quad.]</b> <i>u F 9</i> : U/F for quadratics loads
<i>a c c</i>	<b>[Acceleration]</b>	10.0 s
<i>d e c</i>	<b>[Deceleration]</b>	10.0 s
<i>L S P</i>	<b>[Low Speed]</b>	0.0 Hz
<i>H S P</i>	<b>[High Speed]</b>	50.0 Hz
<i>i t H</i>	<b>[Motor Th Current]</b>	Nominal motor current (value depending on drive rating)
<i>F r d</i>	<b>[Forward]</b>	<b>[DI1]</b> <i>d i 1</i> : Digital input DI1
<i>F r l</i>	<b>[Ref Freq 1 Config]</b>	<b>[AI1]</b> <i>A i 1</i> : Analog input AI1
<i>r l</i>	<b>[R1 Assignment]</b>	<b>[Operating State Fault]</b> <i>F L E</i> : the contact opens when the drive has detected error or when the drive has been switched off
<i>b r A</i>	<b>[Dec.Ramp Adapt]</b>	<b>[Yes]</b> <i>Y E S</i> : function active (automatic adaptation of deceleration ramp)
<i>A t r</i>	<b>[Auto Fault Reset]</b>	<b>[No]</b> <i>n o</i> : function inactive
<i>S t t</i>	<b>[Type of stop]</b>	<b>[On Ramp]</b> <i>r n P</i> : on ramp

**NOTE:** If you want to restore the drive presets to their factory values, set **[Restore config.]** *F C 5* to **[Macro Config]** *i n i*.

Verify whether the above values are compatible with the application and modify them if required.

## Application Functions

### Introduction

The following tables show the combinations of functions and applications in order to guide your selection.

The applications in these tables relate to the following applications:

- Borehole pump
- Pumping station
- Boosting station
- Miscellaneous: fan, compressor
- Lift station

Each application has its own special features, and the combinations listed here are not mandatory or exhaustive.

Some functions are designed specifically for a given application. In this case, the application is identified by a tab in the margin on the relevant programming pages.

### Combinations of Functions and Applications

Control functions:

Function	Application				
	Borehole pump	Pumping station	Boosting station	Miscellaneous	Lift station
PID controller	X	X	X	X	
Sleep/wake up			X		
Feedback monitoring	X	X	X	X	X
Pump characteristics	X	X	X	X	X
Pump start stop	X	X	X	X	X
Pipe fill			X	X	
Friction loss compensation			X		
Sensorless flow estimation	X	X		X	X
Jockey pump			X		
Priming pump control			X		
Flow limitation	X	X	X		
Jump frequency					
Automatic restart	X	X		X	X
Catch on fly				X	
Threshold reached	X	X	X	X	X
Mains contactor command	X	X	X	X	X
Reverse disable	X	X	X	X	
Torque limitation				X	
Parameter set switching	X	X	X	X	X
Stop on prolonged speed		X		X	
Acceleration deceleration ramps	X	X	X	X	X
Motor control type	X	X	X	X	X
Motor tune	X	X	X	X	X
Output phase rotation	X	X	X	X	X
Energy parameter	X	X	X	X	X
Data logging	X	X	X	X	X

Monitoring functions:

Function	Application				
	Borehole pump	Pumping station	Boosting station	Miscellaneous	Lift station
Pumpcycle monitoring	X	X	X	X	X
Anti-Jam		X			X
Dry run monitoring	X	X	X	X	X
Pump low flow monitoring	X	X	X	X	X
Thermal pump monitoring	X	X	X	X	X
Inlet pressure monitoring		X	X		
Outlet pressure monitoring	X	X	X	X	
High flow monitoring	X	X	X	X	X
Process underload monitoring	X	X	X	X	X
Process overload monitoring	X	X	X	X	X
Stall monitoring					X
Thermal sensor monitoring	X	X	X	X	X
Surge voltage limitation	X	X	X	X	X
4-20 loss	X	X	X	X	X
Safe Torque Off	X	X	X	X	X

Display functions:

Function	Application				
	Borehole pump	Pumping station	Boosting station	Miscellaneous	Lift station
Energy parameters	X	X	X	X	X
Data logging	X	X	X	X	X



## Basic Functions

### Drive Ventilation

If **[Fan mode] F F  $\Pi$**  is set to:

- **[Standard] S E  $\mathcal{d}$** , the fan is activated during the all run time of the motor. According to drive rating, this could be the only available setting.
- **[Always] r u n**, the fan is always activated.
- **[Economy] E C o**, the fan is activated only if necessary, according to the internal thermal state of the drive.

Fan speed and **[Fan Operation Time] F P b t** are monitored values:

- An abnormal low speed of the fan triggers a warning **[Fan Feedback Warning] F F  $\mathcal{d}$   $\mathcal{H}$** .
- As soon as **[Fan Operation Time] F P b t** reach the predefined value of 45,000 hours, a warning **[Fan Counter Warning] F C t  $\mathcal{H}$**  is triggered.

**[Fan Operation Time] F P b t** counter can be set to 0 by using the **[Counter Reset] r P r** parameter.

## Graphic Display Terminal

### Description of the Graphic Display Terminal

This Graphic Display Terminal is a local control unit which can be either plugged on the drive or mounted on the door of the wall-mounted or floor-standing enclosure. It has a cable with connectors, which is connected to the drive front Modbus serial link. The Graphic Display Terminal embeds a real time clock used for the time stamping of logged data and all other functions which require time information.

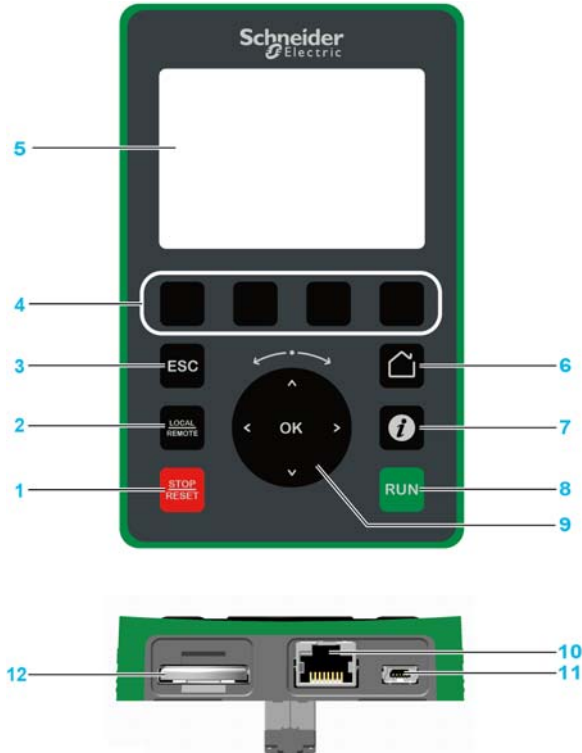

- 1 **STOP / RESET:** Stop command / apply a Fault Reset.
- 2 **LOCAL / REMOTE:** used to switch between local and remote control of the drive.
- 3 **ESC:** used to quit a menu/parameter or remove the currently displayed value in order to revert to the previous value retained in the memory
- 4 **F1 to F4:** function keys used to access drive id, QR code, quick view, and submenus. Simultaneous press of F1 and F4 keys generates a screenshot file in the Graphic Display Terminal internal memory.
- 5 **Graphic display.**
- 6 **Home:** used to access directly at the home page.
- 7 **Information:** used to have more information about menus, submenus, and parameters. The selected parameter or menu code is displayed on the first line of the information page.
- 8 **RUN:** executes the function assuming it has been configured.
- 9 **Touch wheel / OK:** used to save the current value or access the selected menu/parameter. The touch wheel is used to scroll fast into the menus. Up/down arrows are used for precise selections, right/left arrows are used to select digits when setting a numerical value of a parameter.
- 10 **RJ45 Modbus serial port:** used to connect the Graphic Display Terminal to the drive in remote control.
- 11 **MiniB USB port:** used to connect the Graphic Display Terminal to a computer.
- 12 **Battery** (10 years service life. Type: CR2032). The battery positive pole points to the front face of the Graphic Display Terminal.

**NOTE:** Keys 1, 8 and 9 can be used to control the drive if control via the Graphic Display Terminal is activated. To activate the keys on the Graphic Display Terminal, you first need to set **[Ref Freq 1 Config] F r 1** to **[Ref.Freq-Rmt.Term] L C C**.

**Description of the Graphic Display**

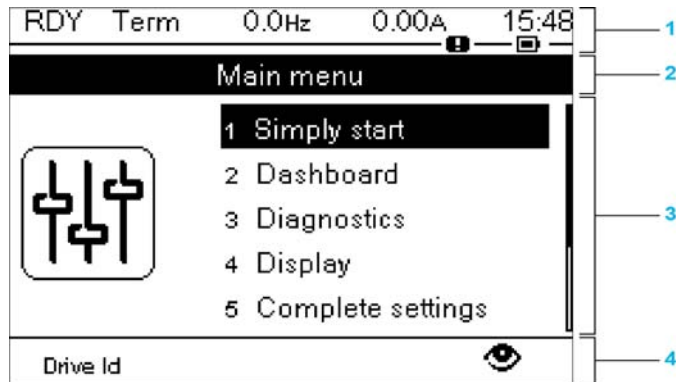

- 1 Display line: its content can be configured
- 2 Menu line: indicates the name of the current menu or submenu
- 3 Menus, submenus, parameters, values, bar charts, and so on, are displayed in drop-down window format on a maximum of five lines. The line or value selected by the navigation button is displayed in reverse video
- 4 Section displaying tabs (1 to 4 by menu), these tabs can be accessed using F1 to F4 keys

Display line details:

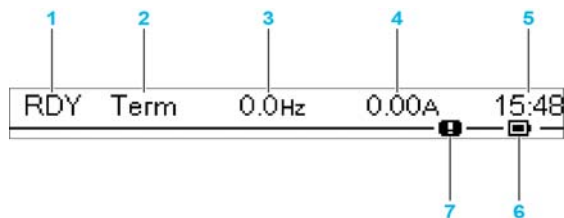

Key	
1	Drive state
2	Active control channel <ul style="list-style-type: none"> <li>● TERM: terminals</li> <li>● HMI: Graphic Display Terminal</li> <li>● MDB: integrated Modbus serial</li> <li>● CAN: CANopen®</li> <li>● NET: fieldbus module</li> <li>● ETH: integrated Ethernet Modbus TCP</li> </ul>
3	Customer defined
4	Customer defined
5	Present time
6	Battery level
7	Warning indicator

**Description of the Product Front LEDs**

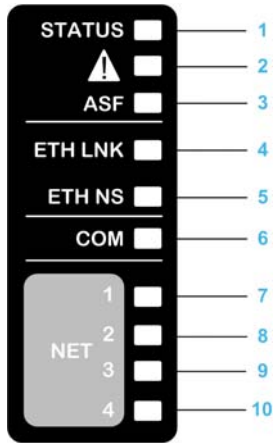

Following table provides the details of the drive status LEDs:

Item	LED	Color & Status	Description
1	STATUS	OFF	Indicates that the drive is powered off
		Green flashing	Indicates that the drive is not running, ready to start
		Green blinking	Indicates that the drive is in transitory status (acceleration, deceleration, and so on)
		Green on	Indicates that the drive is running
2	Warning/Error	Red flashing	Indicates that the drive detected warning
		Red on	Indicates that the drive detected error
3	ASF	Yellow on	Indicates that the safety function is activated

Following table provides the details of the embedded Ethernet LEDs:

Item	LED	Color & Status	Description
4	ETH LNK	OFF	Indicates that the embedded Ethernet link is not established
		Green on	Indicates that the embedded Ethernet link established at 100 Mbit/s
		Green blinking	Indicates embedded Ethernet fieldbus activity at 100 Mbit/s
		Yellow on	Indicates that the embedded Ethernet link established at 10 Mbit/s
		Yellow blinking	Indicates embedded Ethernet fieldbus activity at 10 Mbit/s
5	ETH NS	OFF	Indicates that the embedded Ethernet has no IP address
		Green/Red flashing	Indicates power on testing
		Green on	Indicates that the embedded Modbus TCP connection is established to the command word
		Green flashing	Indicates that the embedded Ethernet has a valid IP, but no Modbus TCP connection to the command word
		Red on	Indicates that the embedded Ethernet has detected a duplicated IP address
		Red	Indicate that the embedded Modbus TCP connection established to control the command word is closed or timed out

Following table provides the details of the embedded Modbus serial LEDs:

Item	LED	Color & Status	Description
6	COM	Yellow flashing	Indicates embedded Modbus serial activity

Following table provides the details of the fieldbus module LEDs:

Item	LED	Color & Status	Description
7	NET 1	Green/Yellow	for details, refer to the fieldbus manual
8	NET 2	Green/Red	for details, refer to the fieldbus manual
9	NET 3	Green/Red	for details, refer to the fieldbus manual
10	NET 4	Green/Yellow	for details, refer to the fieldbus manual

### Graphic Display Terminal Connected to a Computer

## **NOTICE**

### **RISK OF DAMAGE TO THE COMPUTER**

Do not connect the Graphic Display Terminal to the drive via a Modbus RJ45 link and to the computer via a USB link at the same time.

**Failure to follow these instructions can result in equipment damage.**

The Graphic Display Terminal is recognized as a USB storage device named SE\_VW3A1111 while plugged on a computer.

This allows to access the saved drive configurations (DRVCONF menu) and the Graphic Display Terminal screenshots (PRTSCR menu).

Screenshots can be stored by a simultaneous press on F1 and F4 function keys

The Graphic Display Terminal language files can also be accessed and updated (LANG menu).

Language files are available on [www.schneider-electric.com](http://www.schneider-electric.com).

**NOTE:** Prior to make a backup of the original language file before you replace it by another one.

## Structure of the Parameter Table

### General Legend

Pictogram	Description
★	These parameters only appear if the corresponding function has been selected in another menu. When the parameters can also be accessed and adjusted from within the configuration menu for the corresponding function, their description is detailed in these menus, on the pages indicated, to aid programming.
↻	Setting of this parameter can be done during operation or when stopped. <b>NOTE:</b> It is recommended to stop the motor before modifying any of the settings.
⌚	To change the assignment of the parameter, reinforced validation is required.

### Parameter Presentation

Below is an example of a parameter presentation:

[Sample Menu] C o d E – Menu

#### Access

Parameters described below can be accessed by:

[Path] ➔ [Sub-path]

#### About this menu

Description of the menu or function

[Parameter1] C o d E 1

Description of the parameter

*Example of a table with a setting range:*

Setting ( )	Description
0.0... 10,000.0	Setting range Factory setting: 50.0

[Parameter2] C o d E 2

Description of the parameter

*Example of a table with a list of choices:*

Setting ( )	Code / Value	Description
[50 Hz IEC]	5 0	IEC <b>Factory setting</b>
[60 Hz NEMA]	6 0	NEMA

## Finding a Parameter in This Document

### With the Graphic Display Terminal

Select the required parameter and press .

The parameter code is displayed at the top of the information window.

Example: **[Acceleration]** code is *A C C*.

### With the Manual

It is possible to use either the parameter name or the parameter code to search in the manual the page giving details of the selected parameter.

### Difference Between Menu and Parameter

A dash after menu and submenu codes is used to differentiate menu commands from parameter codes.

Example:

Level	Name	Code
Menu	<b>[Ramp]</b>	<i>r A P P -</i>
Parameter	<b>[Acceleration]</b>	<i>A C C</i>





---

# Part II

## Programming

---

### What Is in This Part?

This part contains the following chapters:

Chapter	Chapter Name	Page
3	[Simply start] <i>S Y S -</i>	43
4	[Dashboard] <i>d S H -</i>	53
5	[Diagnostics] <i>d i A -</i>	67
6	[Display] <i>П о н -</i>	89
7	[Complete settings] <i>С С Е -</i>	161
8	[Communication] <i>С о П -</i>	709
9	[File management] <i>F П Е -</i>	723
10	[My preferences] <i>П У Р -</i>	729



---

# Chapter 3

## [Simply start] 5 4 5 -

---

### Introduction



[Simply start] 5 4 5 - menu contains 3 tabs for quick access to mains features:

- Simply Start tab which gives a quick access to basic parameters to set.
- My Menu tab which is a user-defined menu for quick access to specific parameters.
- Modified Parameters tab which gives a quick access to the last modified parameters.

### What Is in This Chapter?

This chapter contains the following topics:

Topic	Page
[Simply start] 5 4 5 - Menu	44
[My menu] 5 4 5 - Menu	50
[Modified parameters] 5 4 5 - Menu	51

## [Simply start] 5 , Π - Menu

### Access

[Simply start] → [Simply start]

### About This Menu

This menu provides a quick access to the basic parameters to set.

### [Motor Standard] b F r ★

Motor standard.

This parameter can be accessed if [Motor control type] C E E is not set to [SYN\_U VC] 5 4 n u.

This parameter modifies the presets of the following parameters:

- [High Speed] H S P
- [Motor Freq Thd] F E d
- [Nom Motor Voltage] u n 5
- [Nominal Motor Freq] F r 5
- [Max Frequency] E F r

Setting	Code / Value	Description
[50 Hz IEC]	5 0	IEC Factory setting
[60 Hz NEMA]	6 0	NEMA

### [Nominal motor power] n P r ★

Nominal motor power.

This parameter can be accessed if:

- [Motor control type] C E E is not set to [SYN\_U VC] 5 4 n u, and
- [Motor param choice] Π P C is set to [Mot Power] n P r.

Rated motor power given on the nameplate, in kW if [Motor Standard] b F r is set to [50Hz IEC] 5 0, in HP if [Motor Standard] b F r is set to [60Hz NEMA] 6 0.

Setting	Description
According to drive rating	– Factory setting: according to the drive rating

### [Nom Motor Voltage] u n 5 ★

Nominal motor voltage.

This parameter can be accessed if [Motor control type] C E E is not set to [SYN\_U VC] 5 4 n u.

Rated motor voltage given on the nameplate.

Setting	Description
100.0...690.0 Vac	Setting range Factory setting: according to drive rating and [Motor Standard] b F r

### [Nom Motor Current] n C r ★

This parameter can be accessed if [Motor control type] C E E is not set to [SYN\_U VC] 5 4 n u.

Rated motor current given on the nameplate.

Setting	Description
0.25...1.5 In <sup>(1)</sup>	Setting range Factory setting: according to drive rating and [Motor Standard] b F r
(1) Corresponding to the rated drive current indicated in the installation manual and on the drive nameplate.	

**[Nominal Motor Freq]  $F_r 5$  ★**

Nominal motor frequency.

This parameter can be accessed if **[Motor control type]  $CLE$**  is not set to **[SYN\_U VC]  $SYNU$** .

The factory setting is 50 Hz, or preset to 60 Hz if **[Motor Standard]  $BFr$**  is set to 60 Hz.

Setting	Description
40.0...500.0 Hz	Setting range <b>Factory setting:</b> 50.0 Hz

**[Nominal Motor Speed]  $n 5 P$  ★**

Nominal motor speed.

This parameter can be accessed if **[Motor control type]  $CLE$**  is not set to **[SYN\_U VC]  $SYNU$** .

If the nameplate indicates the synchronous speed and the slip in Hz or as a %, use one of the formulas to calculate the rated speed:

- Nominal speed = Synchronous speed  $\times \frac{100 - \text{slip as a \%}}{100}$
- Nominal speed = Synchronous speed  $\times \frac{60 - \text{slip in Hz}}{60}$  (60 Hz motors)
- Nominal speed = Synchronous speed  $\times \frac{50 - \text{slip in Hz}}{50}$  (50 Hz motors).

Setting	Description
0...65,535 rpm	Setting range <b>Factory setting:</b> according to drive rating

**[Motor 1 Cosinus Phi]  $C \phi 5$  ★**

Nominal motor cosinus Phi.

This parameter can be accessed if:

- **[Motor control type]  $CLE$**  is not set to **[SYN\_U VC]  $SYNU$** , and
- **[Motor param choice]  $PPC$**  is set to **[Mot Cosinus]  $C \phi 5$** .

Setting	Description
0.50...1.00	Setting range <b>Factory setting:</b> according to the drive rating

**[2/3-Wire Control]**  $\text{E C C}$  

2-wire or 3-wire control.

**⚠ WARNING**

**UNANTICIPATED EQUIPMENT OPERATION**

If this parameter is changed, the parameters **[Reverse Assign]**  $r r 5$  and **[2-wire type]**  $\text{E C E}$  and the assignments of the digital inputs are reset to the factory setting.

Verify that this change is compatible with the type of wiring used.

**Failure to follow these instructions can result in death, serious injury, or equipment damage.**

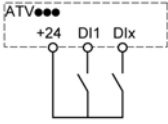
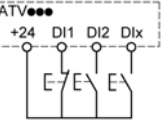
Setting	Code / Value	Description
<b>[2-Wire Control]</b>	$\text{2 C}$	<p><b>2-wire control (level commands):</b> This is the input state (0 or 1) or edge (0 to 1 or 1 to 0), which controls running or stopping.</p> <p>Example of <b>source</b> wiring:</p> <div style="text-align: center;">  </div> <p><b>DI1</b> Forward <b>DIx</b> Reverse</p> <p><b>Factory setting</b></p>
<b>[3-Wire Control]</b>	$\text{3 C}$	<p><b>3-wire control (pulse commands) [3 wire]:</b> A <b>forward</b> or <b>reverse</b> pulse is sufficient to command starting, a <b>stop</b> pulse is sufficient to command stopping.</p> <p>Example of <b>source</b> wiring:</p> <div style="text-align: center;">  </div> <p><b>DI1</b> Stop <b>DI2</b> Forward <b>DIx</b> Reverse</p>

**[Max Frequency]**  $\text{E F r}$

Maximum output frequency.

The factory setting is 60 Hz, or preset to 72 Hz if **[Motor Standard]**  $\text{b F r}$  is set to 60 Hz.

Setting	Description
10.0...500.0 Hz	Setting range <b>Factory setting:</b> 60 Hz

## [Autotuning] $t_{un}$

### DANGER

#### HAZARD OF ELECTRIC SHOCK OR ARC FLASH

During [Autotuning]  $t_{un}$ , the motor operates at nominal current.

- Verify that the same precautions are in place during [Autotuning]  $t_{un}$  as during normal operation of the motor as specified in product manuals and in the manual of the motor.

**Failure to follow these instructions will result in death or serious injury.**

### WARNING

#### LOSS OF CONTROL

- The parameters [Nom Motor Voltage]  $u_n$ , [Nominal Motor Freq]  $f_r$ , [Nom Motor Current]  $i_n$ , [Nominal Motor Speed]  $n_s$ , and [Nominal motor power]  $p_r$  or [Motor 1 Cosinus Phi]  $\cos\phi$  must be correctly set before starting autotuning.
- When one or more of these parameters have been changed after autotuning has been performed, [Autotuning]  $t_{un}$  will return  $no$  and the autotuning will have to be repeated.

**Failure to follow these instructions can result in death, serious injury, or equipment damage.**

In any case, the motor has to be stopped before performing a tune operation. Verify that the application does not make the motor turn during the tune operation.

The tune operation optimizes:

- The motor performances at low speed.
- The estimation of the motor torque.
- The accuracy of the estimation of the process values in sensorless operation and monitoring.

Autotuning is only performed if no stop command has been activated. If a “freewheel stop” or “fast stop” function has been assigned to a digital input, this input must be set to 1 (active at 0).

Autotuning takes priority over any run or prefluxing commands, which will be taken into account after the autotuning sequence.

If autotuning has detected error, the drive always displays [No action]  $no$  and, depending on the configuration of [Tuning Error Resp]  $t_{en}$ , may switch to [Autotuning]  $t_{un}$  detected error mode.

Autotuning may last for several seconds. Do not interrupt the process. Wait for the Graphic Display Terminal to change to [No action]  $no$ .

**NOTE:** The motor thermal state has a significant influence on the tuning result. Always perform a motor tuning with the motor stopped and cold. Verify that the application does not have the motor operate during a tuning operation.

To redo a motor tuning, wait that it is stopped and cold. Set first [Autotuning]  $t_{un}$  to [Erase Autotuning]  $cl_r$ , then redo the motor tuning.

The use of the motor tuning without doing a [Erase Autotuning]  $cl_r$  first is used to get the thermal state estimation of the motor.

The cable length has an influence on the tune result. If the wiring is modified, it is necessary to redo the tune operation.

Setting ( )	Code / Value	Description
[No action]	$no$	Autotuning not in progress <b>Factory setting</b>
[Apply Autotuning]	$yes$	Autotuning is performed immediately if possible, then the parameter automatically changes to [No action] $no$ . If the drive state does not allow the tune operation immediately, the parameter changes to [No] $no$ and the operation must be done again.
[Erase Autotuning]	$cl_r$	The motor parameters measured by the autotuning function are reset. The default motor parameter values are used to control the motor. [Autotuning Status] $t_{us}$ is set to [Not done] $tf_b$ .

**[Autotuning Status] *t u 5***

Autotuning status.

(for information only, cannot be modified)

This parameter is not saved at drive power off. It shows the autotuning status since last power-on.

Setting ( )	Code / Value	Description
[Not done]	<i>t R b</i>	Autotune is not done <b>Factory setting</b>
[Pending]	<i>P E n d</i>	Autotune has been requested but not yet performed
[In Progress]	<i>P r o G</i>	Autotune is in progress
[Error]	<i>F R , L</i>	Autotune has detected error
[Autotuning Done]	<i>d o n e</i>	The motor parameters measured by the autotuning function are used to control the motor

**[Motor Th Current] *, t H***

Motor thermal monitoring current to be set to the rated current indicated on the nameplate.

Setting ( )	Description
0.2...1.1 In <sup>(1)</sup>	Setting range <b>Factory setting:</b> According to drive rating
<b>(1)</b> Corresponding to the rated drive current indicated in the installation manual and on the drive nameplate.	

**[Acceleration] *R C L***

Time to accelerate from 0 to the **[Nominal Motor Freq] *F r 5***. To have a repeatability in the ramps, the value of this parameter must be set according to the possibility of the application.

Setting ( )	Description
0.0...6,000.0 s <sup>(1)</sup>	Setting range <b>Factory setting:</b> 10.0 s
<b>(1)</b> Range 0.01 to 99.99 s or 0.1 to 999.9 s or 1...6,000 s according to <b>[Ramp increment] <i>i n r</i></b> .	

**[Deceleration] *d E L***

Time to decelerate from the **[Nominal Motor Freq] *F r 5*** to 0. To have a repeatability in the ramps, the value of this parameter must be set according to the possibility of the application.

Setting ( )	Description
0.0...6,000.0 s <sup>(1)</sup>	Setting range <b>Factory setting:</b> 10.0 s
<b>(1)</b> Range 0.01 to 99.99 s or 0.1 to 999.9 s or 1...6,000 s according to <b>[Ramp increment] <i>i n r</i></b> .	



**[Low Speed]  $LSP$** 

Low speed.

Motor frequency at minimum reference, can be set between 0 and **[High Speed]  $HSP$** .

Setting ( )	Description
0.0... <b>[High Speed] <math>HSP</math></b> Hz	Setting range <b>Factory setting:</b> 0.0 Hz

**[High Speed]  $HSP$** 

High speed.

Motor frequency at maximum reference, can be set between **[Low Speed]  $LSP$**  and **[Max Frequency]  $EFr$** . The factory setting changes to 60 Hz if **[Motor Standard]  $BFr$**  is set to **[60Hz NEMA]  $BD$** .

Setting ( )	Description
0.0... <b>[Max Frequency] <math>EFr</math></b> Hz	Setting range <b>Factory setting:</b> 50.0 Hz

## [My menu] *ΠΥΠΠ* - Menu

### Access

[Simply start] → [My menu]

### About This Menu

This menu contains the parameters selected in the [My menu config.] *ΠΥΣ* - Menu.

**NOTE:** This menu is empty by default.

## [Modified parameters] *L Π d* - Menu

### Access

[Simply start] → [Modified parameters]

### About This Menu

This menu gives a quick access to the 10 last modified parameters



---

# Chapter 4

## [Dashboard] *d S H* -

---

### Introduction



**[Dashboard] *d S H* -** menu contains tabs for quick access to control and display features:

- Dashboard tabs which allows you to access the main display parameters.
- Control tabs to configure the main control parameters.
- Energy tab which provides a complete access for instantaneous power counters and energy reports by means of graphics on the Graphic Display Terminal.

### What Is in This Chapter?

This chapter contains the following topics:

Topic	Page
<b>[Pump dashboard] <i>P P L</i> - Menu</b>	54
<b>[Fan dashboard] <i>F R n</i> - Menu</b>	56
<b>[Dashboard] <i>d S H</i> - Menu</b>	58
<b>[Control] <i>L E r</i> - Menu</b>	59
<b>[Control] <i>F E r</i> - Menu</b>	62
<b>[Dashboard] <i>d S H</i> - Menu</b>	63
<b>[Energy] <i>K W C</i> - Menu</b>	64
<b>[Dashboard] <i>d S H</i> - Menu</b>	66

## [Pump dashboard] *P P L* - Menu

### Access

[Dashboard] → [Pump dashboard]

### About This Menu

This menu provides informations related to the pump.

This menu can be accessed if [Application Selection] *A P P L* is not set to [Generic Fan Control] *F A n*.

### [Pre-Ramp Ref Freq] *F r H*

Frequency reference before ramp (signed value).

Actual frequency reference lied to the motor regardless of which reference channel has been selected. This parameter is in read-only mode.

Setting	Description
-[High Speed] <i>H S P</i> ...[High Speed] <i>H S P</i> Hz	Setting range Factory setting: –

### [Drive State] *H n , S*

Drive state.

Setting	Code / Value	Description
[Autotuning]	<i>t u n</i>	Autotuning
[In DC inject.]	<i>d C b</i>	DC Injection
[Ready]	<i>r d y</i>	Drive ready
[Freewheel]	<i>n S t</i>	Freewheel stop control
[Running]	<i>r u n</i>	Motor in steady state or run command present and zero reference
[Accelerating]	<i>A C C</i>	Acceleration
[Decelerating]	<i>d E C</i>	Deceleration
[Current limitation]	<i>C L ,</i>	In current limitation
[Fast stop]	<i>F S t</i>	Fast stop
[Mot. fluxing]	<i>F L u</i>	Fluxing function is activated
[No Mains Voltage]	<i>n L P</i>	Control is powered on but the DC bus is not loaded
[control.stop]	<i>C t L</i>	Controlled stop
[Dec. adapt.]	<i>a b r</i>	Adapted deceleration
[Output cut]	<i>S o C</i>	Stand by output cut
[Undervoltage Warning]	<i>u S R</i>	Undervoltage warning
[In autotest]	<i>S t</i>	Self test in progress
[Autotest error]	<i>F A</i>	Self test detected error
[Autotest OK]	<i>Y E S</i>	Self test OK
[EEProm test]	<i>E P</i>	Self test EEPROM detected error
[“Operating State "Fault"“]	<i>F L t</i>	Product has detected an error
[DCP Flashing Mode]	<i>d C P</i>	DCP flashing mode
[STO Active]	<i>S t o</i>	Safe Torque Off active
[Energy Saving]	<i>i d L E</i>	Idle stop and go mode

**[MultiPump State] *Π P S* ★**

Multipump function state.

This parameter can be accessed if **[Pump System Architecture] *Π P S A*** is not set to **[No] *η α***.

Setting	Code / Value	Description
<b>[None]</b>	<i>η α η E</i>	None
<b>[Ready]</b>	<i>r E A d Y</i>	Ready
<b>[Running]</b>	<i>r u n</i>	Running
<b>[Warning]</b>	<i>A L A r Π</i>	Warning
<b>[Error]</b>	<i>F A u L t</i>	Error

**[Available Pumps] *Π P A η* ★**

Number of available pumps.

This parameter can be accessed if **[Pump System Architecture] *Π P S A*** is not set to **[No] *η α***.

Setting	Description
0...65,535	Setting range Factory setting: –

**[Nb of Staged Pumps] *Π P S η* ★**

Number of staged pumps.

This parameter can be accessed if **[Pump System Architecture] *Π P S A*** is not set to **[No] *η α***.

Setting	Description
0...65,535	Setting range Factory setting: –

**[Motor Current] *L C r***

Motor current.

Setting	Description
According to drive rating	Setting range Factory setting: –

**[Motor speed] *S P d***

Motor speed in rpm.

Setting	Description
0...65,535 rrpm	Setting range Factory setting: –

**[Motor Therm state] *t H r***

Motor thermal state.

The normal motor thermal state is 100%, the **[Motor Overload] *α L F*** threshold is set to 118%.

Setting	Description
0...200%	Setting range Factory setting: –

**[Fan dashboard] *F A n* - Menu****Access****[Dashboard] → [Fan dashboard]****About This Menu**

This menu provides informations related to the fan.

This menu can be accessed if **[Application Selection] *A P P L*** is set to **[Generic Fan Control] *F A n***.

**[Pre-Ramp Ref Freq] *F r H***

Frequency reference before ramp (signed value).

Actual frequency reference lied to the motor regardless of which reference channel has been selected. This parameter is in read-only mode.

Setting	Description
<b>-[High Speed] <i>H S P</i>...[High Speed] <i>H S P</i> Hz</b>	Setting range <b>Factory setting: –</b>

**[Drive State] *H n , S***

Drive state.

Setting	Code / Value	Description
<b>[Autotuning]</b>	<i>t u n</i>	Autotuning
<b>[In DC inject.]</b>	<i>d C b</i>	DC Injection
<b>[Ready]</b>	<i>r d y</i>	Drive ready
<b>[Freewheel]</b>	<i>n S t</i>	Freewheel stop control
<b>[Running]</b>	<i>r u n</i>	Motor in steady state or run command present and zero reference
<b>[Accelerating]</b>	<i>A C C</i>	Acceleration
<b>[Decelerating]</b>	<i>d E C</i>	Deceleration
<b>[Current limitation]</b>	<i>C L ,</i>	In current limitation
<b>[Fast stop]</b>	<i>F S t</i>	Fast stop
<b>[Mot. fluxing]</b>	<i>F L u</i>	Fluxing function is activated
<b>[No Mains Voltage]</b>	<i>n L P</i>	Control is powered on but the DC bus is not loaded
<b>[control.stop]</b>	<i>C t L</i>	Controlled stop
<b>[Dec. adapt.]</b>	<i>a b r</i>	Adapted deceleration
<b>[Output cut]</b>	<i>S o C</i>	Stand by output cut
<b>[Undervoltage Warning]</b>	<i>u S R</i>	Undervoltage warning
<b>[In autotest]</b>	<i>S t</i>	Self test in progress
<b>[Autotest error]</b>	<i>F A</i>	Self test detected error
<b>[Autotest OK]</b>	<i>Y E S</i>	Self test OK
<b>[EEProm test]</b>	<i>E P</i>	Self test EEPROM detected error
<b>["Operating State "Fault""]</b>	<i>F L t</i>	Product has detected an error
<b>[DCP Flashing Mode]</b>	<i>d C P</i>	DCP flashing mode
<b>[STO Active]</b>	<i>S t o</i>	Safe Torque Off active
<b>[Energy Saving]</b>	<i>i d L E</i>	Idle stop and go mode



**[Motor Current] L C r**

Motor current.

Setting	Description
According to drive rating	Setting range <b>Factory setting:</b> –

**[Motor speed] S P d**

Motor speed in rpm.

Setting	Description
0...65,535 rrpm	Setting range <b>Factory setting:</b> –

**[Motor Therm state] t H r**

Motor thermal state.

The normal motor thermal state is 100%, the **[Motor Overload] o L F** threshold is set to 118%.

Setting	Description
0...200%	Setting range <b>Factory setting:</b> –

## [Dashboard] *d S H* - Menu

### Access

[Dashboard]

### About This Menu

Using **F4** function key on the Graphic Display Terminal, it is possible to select one of the following view for the **[Pump dashboard]** or **[Fan dashboard]** tab.

Pump curves and actual working point are available if valid pump characteristics have been entered and if **[Pump Curve Activate] P C A** is set to **[Yes] Y E S**.

### [Operating time report] *H O E*

Displays the operating time histogram.

### [Nb start report] *H n S*

Displays the number of start histogram.

### [Power vs Flow] *C P Q*

This shows the mechanical power versus the flow curve of the system.

### [Head vs Flow] *C H Q*

This shows the head of the pump versus the flow curve of the system.

### [Efficiency vs Flow] *C E Q*

This shows the efficiency (%) versus flow curve of the system.

### [Efficiency ] *E F F*

Displays the instantaneous efficiency curve.

## [Control] *Ctrl* - Menu

### Access

[Dashboard] → [Control]

### About This Menu

This menu can be accessed if [Application Selection] *APPE* is not set to [Generic Fan Control] *FAN*.

### [Application State] *APPS*

Application state.

Setting	Code / Value	Description
[Running]	<i>run</i>	No application function in progress; the drive is running
[Stop]	<i>STOP</i>	No application function in progress; the drive is not running
[Local Mode Active]	<i>LOCAL</i>	Forced local mode activated
[Channel 2 Active]	<i>OVER</i>	Override speed control mode activated
[Manual Mode Active]	<i>MANU</i>	Motor running; manual PID mode is active
[PID Active]	<i>AUTO</i>	Motor running; auto PID mode is active
[Antijam In Progress]	<i>AJAP</i>	The Anti-jam is in progress
[Flow Limit In Progress]	<i>FLIP</i>	The flow limitation is in progress
[PipeFill In Progress]	<i>FILL</i>	The pipe fill is in progress
[Jockey Pump Active]	<i>JOCKEY</i>	The jockey pump is active
[Boost In progress]	<i>BOOST</i>	The boost is in progress
[Sleep Active]	<i>SLEEP</i>	The sleep is active
[Priming Pump Active]	<i>PRIP</i>	The priming pump is active
[InletPres Comp In Progress]	<i>COMP</i>	The inlet pressure compensation is in progress

### [Booster Status] *BCS* ★

Booster status.

This parameter can be accessed if [Application Selection] *APPE* is set to [Pump Booster Control] *BOOST*.

Setting	Code / Value	Description
[None]	<i>NONE</i>	Not configured
[Inactive]	<i>INACT</i>	Inactive
[Running]	<i>run</i>	Running
[Stage Pending]	<i>STGP</i>	Stage pending
[Destage Pending]	<i>DESTGP</i>	Destage pending
[Staging]	<i>STG</i>	Staging
[Destaging]	<i>DESTG</i>	Destage in progress

**[LevelCtrl Status] L C 5 ★**

Level control status.

This parameter can be accessed if **[Application Selection] APPE** is set to **[Pump Level Control] LEVEL**.

Setting	Code / Value	Description
[None]	<i>n o n E</i>	Not configured
[Inactive]	<i>n A c t</i>	Inactive
[Filling]	<i>F i L L</i>	Filling in progress
[Emptying]	<i>E m P t y</i>	Emptying in progress
[Low Level]	<i>L o w - L E V E L</i>	Low level
[High Level]	<i>h i G h - L E V E L</i>	High level

**[Tank Level] L C 6 L ★**

Tank level.

This parameter can be accessed if **[Application Selection] APPE** is set to **[Pump Level Control] LEVEL**.

Setting	Description
0.0...100.0%	Setting range Factory setting: –

**[PID Reference] r P C ★**

PID reference.

This parameter can be accessed if **[PID Feedback] P i F** is set to **[Not Configured] n o**.

Setting	Description
0...65,535%	Setting range Factory setting: –

**[PID Feedback] r P F ★**

PID feedback.

This parameter can be accessed if **[PID Feedback] P i F** is set to **[Not Configured] n o**.

Setting	Description
0...65,535%	Setting range Factory setting: –

**[Outlet Pressure] P 5 2 u**

Outlet pressure value.

Setting	Description
-32,767...32,767	Setting range Factory setting: –

**[Inlet Press. Value] P 5 1 u**

Inlet pressure value.

Setting	Description
-32,767...32,767	Setting range Factory setting: –

**[Installation Flow]** *F 5 I* 

Flow rate sensor value.

Setting	Description
-32,767...32,767	Setting range <b>Factory setting:</b> –

**[Flow Estimated]** *S L F V* 

Estimated flow value.

This parameter can be accessed if **[Flow Estimation Mode]** *F E M* is set to **[No]** *n o*.

Setting	Description
-32,767...32,767	Setting range <b>Factory setting:</b> –

## [Control] *F E r* - Menu

### Access

[Dashboard] → [Control]

### About This Menu

This menu can be accessed if [Application Selection] *A P P E* is set to [Generic Fan Control] *F R n*.

### [PID Reference] *r P E* ★

PID reference.

This parameter can be accessed if [PID Feedback] *P i F* is set to [Not Configured] *n o*.

Setting	Description
0...65,535%	Setting range Factory setting: –

### [PID Feedback] *r P F* ★

PID feedback.

This parameter can be accessed if [PID Feedback] *P i F* is set to [Not Configured] *n o*.

Setting	Description
0...65,535%	Setting range Factory setting: –

---

## [Dashboard] *d S H* - Menu

### Access

[Dashboard]

### About This Menu

Using **F4** function key on the Graphic Display Terminal, it is possible to select one of the following view for the **[Control]** tab.

### [PID Feedback Trend] *P F L*

Displays the instantaneous PID controller feedback curve.

### [Outlet Pressure Trend] *o P L*

Displays the instantaneous outlet pressure curve.

### [Inlet Pressure Trend] *i P L*

Displays the instantaneous inlet pressure curve.

### [Installation Flow Trend] *i F L*

Displays the instantaneous installation flow curve.

## [Energy] K W L - Menu

### Access

[Dashboard] → [Energy]

### About This Menu

This menu presents many energy objects available for instantaneous data and kW consumption reports. It offers the possibility to display logged data with graphics by pressing the F4 function key.

#### [Elc energy cons(TWh)] $\alpha$ C 4 ★

Electrical energy consumed by the motor in TWh.

This parameter can be accessed if [Elc energy cons(TWh)]  $\alpha$  C 4 is not set to 0.

Setting	Description
0...999 TWh	Setting range Factory setting: –

#### [Elc energy cons(GWh)] $\alpha$ C 3 ★

Electrical energy consumed by the motor in GWh.

This parameter can be accessed if:

- [Elc energy cons(TWh)]  $\alpha$  C 4 is set to 0 and
- [Elc energy cons(GWh)]  $\alpha$  C 3 is not set to 0

Setting	Description
0...999 GWh	Setting range Factory setting: –

#### [Elc energy cons(MWh)] $\alpha$ C 2 ★

Electrical energy consumed by the motor in MWh.

This parameter can be accessed if:

- [Elc energy cons(TWh)]  $\alpha$  C 4 is set to 0 and
- [Elc energy cons(GWh)]  $\alpha$  C 3 is set to 0 and
- [Elc energy cons(MWh)]  $\alpha$  C 2 is not set to 0

Setting	Description
0...999 MWh	Setting range Factory setting: –

#### [Elc energy cons(kWh)] $\alpha$ C 1 ★

Electrical energy consumed by the motor in kWh.

This parameter can be accessed if:





- [Elc energy cons(TWh)]  $\alpha$  C 4 is set to 0 and
- [Elc energy cons(GWh)]  $\alpha$  C 3 is set to 0 and
- [Elc energy cons(MWh)]  $\alpha$  C 2 is set to 0 and
- [Elc energy cons(kWh)]  $\alpha$  C 1 is not set to 0

Setting	Description
0...999 kWh	Setting range Factory setting: –



**[Elc energy cons(Wh)]**    

Electrical energy consumed by the motor in Wh.

This parameter can be accessed if **[Elc energy cons(TWh)]** , **[Elc energy cons(GWh)]** , **[Elc energy cons(MWh)]**  and **[Elc energy cons(kWh)]**  are all set to 0.

Setting	Description
0...999 Wh	Setting range <b>Factory setting:</b> –

**[Acv Elc out pwr estm]** *E P r W*

Active electrical output power estimation.

Setting	Description
-32,768...32,767	Setting range Value in kW or HP according to <b>[Motor Standard]</b> <i>b F r</i> setting <b>Factory setting:</b> –

**[Elc Egy Today]**  

Electrical energy consumed today by the motor in kWh.

Setting	Description
0...4,294,967,295 kWh	Setting range <b>Factory setting:</b> –

**[Elc Egy Yesterday]**  

Electrical energy consumed yesterday by the motor in kWh.

Setting	Description
0...4,294,967,295 kWh	Setting range <b>Factory setting:</b> –

## [Dashboard] *d S H* - Menu

### Access

[Dashboard]

### About This Menu

Using **F4** function key on the Graphic Display Terminal, it is possible to select one of the following view for the **[Energy]** tab.

### [Instant kW Trend] *l V l*

Displays the instantaneous electrical energy curve at the drive output.

### [Daily kWh Report] *H S d*

Displays the daily energy histogram.

### [Weekly kWh Report] *H S w*

Displays the weekly energy histogram.

### [Monthly kWh Report] *H S m*

Displays the monthly energy histogram.

### [Yearly kWh Report] *H S y*

Displays the yearly energy histogram.

---

# Chapter 5

## [Diagnostics] $d$ , $R$ -

---

### Introduction



[Diagnostics]  $d$  ,  $R$  - menu presents drive and application data useful when diagnostics is required.

### What Is in This Chapter?

This chapter contains the following sections:

Section	Topic	Page
5.1	[Diag. data]	68
5.2	[Error history]	77
5.3	[Warnings]	80

---

## Section 5.1

### [Diag. data]

---

#### What Is in This Section?

This section contains the following topics:

Topic	Page
[Diag. data] <i>d d t</i> - Menu	69
[Service message] <i>S E r</i> - Menu	73
[Other State] <i>S S t</i> - Menu	74
[Diagnostics] <i>d R u</i> - Menu	75
[Identification] <i>o i d</i> - Menu	76

**[Diag. data] d d t - Menu****Access**

[Diagnostics] → [Diag. data]

**About This Menu**

This menu presents the actual warning and detected error in addition to drive data.

**[Last Warning] L A L r**

Last warning which occurred.

Setting	Code / Value	Description
[No Warning Stored]	n o R	No warning stored
[Fallback speed]	F r F	Reaction on event / fallback speed
[Speed Maintained]	r L S	Reaction on event / maintain speed
[Type of Stop]	S t t	Reaction on event / stop on [Type of stop] S t t without tripping in error
[Ref Frequency Warning]	S r R	Frequency reference reached
[Life Cycle Warn 1]	L C R 1	Life cycle warning 1
[Life Cycle Warn 2]	L C R 2	Life cycle warning 2
[Drive Running Warning]	d r Y R	Drive running warning
[Low Flow Warning]	L F R	Low flow warning
[High Flow Warning]	H F P R	High flow warning
[InPres Warning]	, P P R	Inlet pressure monitoring warning
[Low OutPres Warning]	o P L R	Outlet pressure low warning
[High OutPres Warning]	o P H R	Outlet pressure high warning
[PumpCycle warning]	P C P R	Pumpcycle monitoring warning
[Anti-Jam Warning]	J A P R	Anti-Jam warning is raised
[Pump Low Flow ]	P L F R	Pump low flow warning
[Low Pressure Warning]	L P R	Low-pressure warning is raised
[Flow Limit Activated]	F S R	Flow limit function activated (FL_Mode_On)
[PID Error Warning]	P E E	Warning on PID error
[PID Feedback Warning]	P F R	Warning on PID feedback
[PID High Fdbck Warning]	P F R H	PID feedback high threshold reached
[PID Low Fdbck Warning]	P F R L	PID feedback low threshold reached
[Regulation Warning]	P , S H	PI feedback monitoring warning is raised
[AI2 Th Warning]	t P 2 R	Temperature monitoring AI2 warning
[AI3 Th Warning]	t P 3 R	Temperature monitoring AI3 warning
[AI4 Th Warning]	t P 4 R	Temperature monitoring AI4 warning
[AI5 Th Warning]	t P 5 R	Temperature monitoring AI5 warning
[AI1 4-20 Loss Warning]	R P 1	AI1 4-20 loss warning on AI1
[AI2 4-20 Loss Warning]	R P 2	AI2 4-20 loss warning on AI2
[AI3 4-20 Loss Warning]	R P 3	AI3 4-20 loss warning on AI3
[AI4 4-20 Loss Warning]	R P 4	AI4 4-20 loss warning on AI4
[AI5 4-20 Loss Warning]	R P 5	AI5 4-20 loss warning on AI5
[Drive Thermal Warning]	t H R	Drive overheating warning is raised
[IGBT Thermal Warning]	t J R	Warning on IGBT thermal state
[Fan Counter Warning]	F C t R	Fan counter speed warning
[Fan Feedback Warning]	F F d R	Fan feedback warning is raised
[Ext. Error Warning]	E F R	External error warning
[Undervoltage Warning]	u S R	Undervoltage warning is raised
[Preventive UnderV Active]	u P R	Controlled stop on power loss threshold id reached

Setting	Code / Value	Description
[Motor Freq High Thd]	<i>F L R</i>	Motor frequency high threshold 1 reached
[Motor Freq Low Thd]	<i>F L R L</i>	Motor frequency low threshold 1 reached
[Motor Freq Low Thd 2]	<i>F L R L 2</i>	Motor frequency low threshold 2 reached
[High Speed Reached]	<i>F L R</i>	High speed reached function result
[Ref Freq High Thd Reached]	<i>r L R H</i>	Reference frequency high threshold reached
[Ref Freq High Thd Reached]	<i>r L R L</i>	Reference frequency low threshold reached
[2nd Freq Thd Reached]	<i>F L R</i>	Frequency level reached (frequency meter)
[Ethernet Internal Warning]	<i>i n W n</i>	Ethernet internal warning
[Current Thd Reached]	<i>C L R</i>	Motor current high threshold reached
[Low I Thd Reached]	<i>C L R L</i>	Motor current low threshold reached
[Process Undld Warning]	<i>u L R</i>	Underload is detected
[Process Overload Warning]	<i>o L R</i>	Overload is detected
[Torque Limit Reached]	<i>S S R</i>	Timeout on current or torque limitation is reached
[Drv Therm Thd Reached]	<i>t R d</i>	Drive thermal threshold reached function result
[Motor Therm Thd Reached]	<i>t S R</i>	Motor thermal threshold reached function result (motor 1)
[Power High Threshold]	<i>P L H R</i>	Power high threshold reached
[Power Low Threshold]	<i>P L H L</i>	Power low threshold reached
[Cust Warning 1]	<i>C R S 1</i>	Customer warning 1 active
[Cust Warning 2]	<i>C R S 2</i>	Customer warning 2 active
[Cust Warning 3]	<i>C R S 3</i>	Customer warning 3 active
[Cust Warning 4]	<i>C R S 4</i>	Customer warning 4 active
[Cust Warning 5]	<i>C R S 5</i>	Customer warning 5 active
[Power Cons Warning]	<i>P o W d</i>	Power consumption warning
[Switch OutPres Warning]	<i>o P S R</i>	Outlet pressure high switch warning
[MultiPump Capacity Warn]	<i>n P c R</i>	Multi-Pump available capacity warning
[Lead Pump Warn]	<i>n P L R</i>	Lead Pump not available
[High Level Warning]	<i>L c h R</i>	High level warning
[Low Level Warning]	<i>L c L R</i>	Low level warning
[Level Switch Warning]	<i>L c W R</i>	Level switch warning

**[Last Error] L F L**

Last error which occurred.

Setting	Code / Value	Description
[No Error]	<i>n o F</i>	No error detected
[EEPROM Control]	<i>E E F 1</i>	EEPROM control
[Incorrect Configuration]	<i>C F F</i>	Invalid configuration at power-on
[Invalid Configuration]	<i>C F i</i>	Incorrect parameter configuration
[Modbus Com Interruption]	<i>S L F 1</i>	Modbus local serial communication error
[Internal Link Error ]	<i>i L F</i>	Option internal link error
[Fieldbus Com Interrupt]	<i>C n F</i>	Communication interruption on fieldbus module
[External Error]	<i>E P F 1</i>	External error from LI or local link
[Overcurrent]	<i>o C F</i>	Over current error
[Precharge Capacitor]	<i>C r F</i>	Load relay error
[AI2 4-20mA Loss]	<i>L F F 2</i>	AI2 4-20 mA loss error
[Drive Overheating]	<i>o H F</i>	Drive over heating error
[Motor Overload]	<i>o L F</i>	Motor overload error
[DC Bus Overvoltage]	<i>o b F</i>	DC bus overvoltage
[Supply Mains Overvoltage]	<i>o S F</i>	Over supply error
[Single Output Phase Loss]	<i>o P F 1</i>	Motor 1-phase loss

Setting	Code / Value	Description
[Input Phase Loss]	<i>P H F</i>	Main input 1-phase loss
[Supply Mains UnderV]	<i>u S F</i>	Under voltage error
[Motor Short Circuit]	<i>S C F 1</i>	Motor short circuit error (hard detection)
[Motor Overspeed]	<i>S o F</i>	Instability or driving load too high
[Autotuning Error]	<i>t n F</i>	Tune error
[Internal Error 1]	<i>i n F 1</i>	Unknown drive rating
[Internal Error 2]	<i>i n F 2</i>	Unknown or incompatible power board
[Internal Error 3]	<i>i n F 3</i>	Internal communication error
[Internal Error 4]	<i>i n F 4</i>	Internal data inconsistent
[EEprom Power]	<i>E E F 2</i>	Internal memory error
[Ground Short Circuit]	<i>S C F 3</i>	Direct ground short-circuit error (hard detection)
[Output Phase Loss]	<i>o P F 2</i>	Motor 3-phases loss
[CANopen Com Interrupt]	<i>C o F</i>	CANopen communication error
[Internal Error 7]	<i>i n F 7</i>	CPLD communication error
[Fieldbus Error]	<i>E P F 2</i>	External error from fieldbus module
[Internal Error 8]	<i>i n F 8</i>	Power switching supply error
[PC Com Interruption]	<i>S L F 2</i>	PC software communication interruption
[HMI Com Interruption]	<i>S L F 3</i>	Graphic Display Terminal communication error
[Internal Error 9]	<i>i n F 9</i>	Current measurement circuit failure
[Internal Error 10]	<i>i n F A</i>	Customer supply error
[Internal Error 11]	<i>i n F b</i>	Thermal sensor error (OC or SC)
[IGBT Overheating]	<i>t J F</i>	IGBT over heating error
[IGBT Short Circuit]	<i>S C F 4</i>	IGBT short-circuit error (hard detection)
[Motor Short Circuit]	<i>S C F 5</i>	Load short-circuit error during long load sequence (hard detection)
[Input Contactor]	<i>L C F</i>	Line contactor failure
[Internal Error 6]	<i>i n F 6</i>	Unknown or incompatible option module
[Internal Error 14]	<i>i n F E</i>	CPU error (ram, flash, task ...)
[AI3 4-20 mA Loss]	<i>L F F 3</i>	AI3 4-20 mA loss
[AI4 4-20 mA Loss]	<i>L F F 4</i>	AI4 4-20 mA loss
[Boards Compatibility]	<i>H C F</i>	Hardware configuration error
[Conf Transfer Error]	<i>C F , 2</i>	Configuration transfer error
[AI5 4-20 mA Loss]	<i>L F F 5</i>	AI5 4-20 mA loss
[Channel Switch Error]	<i>C S F</i>	Channel switching error
[Process Underload]	<i>u L F</i>	Torque underload error
[Process Overload]	<i>o L C</i>	Torque overload error
[Angle Error]	<i>A S F</i>	Angle Setting error
[Safety Function Error]	<i>S A F F</i>	Safety function error
[AI1 4-20 mA loss]	<i>L F F 1</i>	AI1 4-20 mA loss
[AI2 Th Detected Error]	<i>t H 2 F</i>	AI2 thermal sensor detected error
[AI2 Thermal Sensor Error]	<i>t 2 C F</i>	Thermal sensor error on AI2
[AI3 Th Detected Error]	<i>t H 3 F</i>	AI3 thermal sensor detected error
[AI3 Thermal Sensor Error]	<i>t 3 C F</i>	Thermal sensor error on AI3
[PumpCycle Start Error]	<i>P C P F</i>	Pumpcycle detected error
[Out Pressure Low]	<i>o P L F</i>	Outlet pressure low
[High Flow Error]	<i>H F P F</i>	High flow error
[Inlet Pressure Error]	<i>i P P F</i>	Inlet pressure detected error
[Pump Low Flow Error]	<i>P L F F</i>	Pump low flow detected error
[AI4 Th Detected Error]	<i>t H 4 F</i>	AI4 thermal sensor detected error
[AI4 Thermal Sensor Error]	<i>t 4 C F</i>	Thermal sensor error on AI4

Setting	Code / Value	Description
[AI5 Th Detected Error]	<i>t H S F</i>	AI5 thermal sensor detected error
[AI5 Thermal Sensor Error]	<i>t S C F</i>	Thermal sensor error on AI5
[Anti Jam Error]	<i>J R P F</i>	Anti-Jam detected error
[Out Pressure High]	<i>a P H F</i>	Outlet pressure high
[Dry Run Error]	<i>d r Y F</i>	Dry run detected error
[PID FeedBack Error]	<i>P F P F</i>	PID feedBack detected error
[Program Loading Error]	<i>P G L F</i>	Program loading detected error
[Program Running Error]	<i>P G r F</i>	Program running detected error
[Lead Pump Error]	<i>P P L F</i>	The selected lead pump is not available
[Low Level Error]	<i>L C L F</i>	The minimum level switch is active during emptying process
[High Level Error]	<i>L C H F</i>	The maximum level switch is active during filling process
[Internal Error 16]	<i>i n F G</i>	Internal error 16
[Internal Error 17]	<i>i n F H</i>	Internal error 17
[Internal Error 0]	<i>i n F D</i>	Internal error 0 (IPC)
[Internal Error 13]	<i>i n F d</i>	Internal error 13 (different current)
[Motor Stall Error]	<i>S t F</i>	Motor stall detected error
[Internal Error 21]	<i>i n F L</i>	Internal error 21 (RTC)
[Embd Eth Com Interrupt]	<i>E t H F</i>	Embedded Ethernet communication interruption
[Internal Error 15]	<i>i n F F</i>	Internal error 15 (flash)
[Internal Error 25]	<i>i n F P</i>	Internal error 25
[Internal Error 20]	<i>i n F K</i>	Internal error 20
[Internal Error 27]	<i>i n F r</i>	Internal error 27
[Internal Error 30]	<i>i n F W</i>	Internal error 30 (firmware update)

**[Nb Of Start] n 5 P**

Number of motor starts.

Setting	Description
0...4,294,967,295	Setting range <b>Factory setting:</b> 0

**[Motor Run Time] r t H**

Motor run time.

Setting	Description
0...4,294,967,295 s	Setting range <b>Factory setting:</b> _



---

## [Service message] 5 E r - Menu

### Access

[Diagnostics] → [Diag. data] → [Service message]

### About This Menu

This menu presents the service messages.

This is a user-defined service message configured in [My preferences] *Π Υ Ρ* → [Customization] *Ε υ 5* → [Service messages] 5 E r .

## [Other State] 5 5 6 - Menu

### Access

[Diagnostics] → [Diag. data] → [Other State]

### About This Menu

List of secondary states.

### List

[Anti-Jam pending] J A Π P  
[Anti-Jam In Progress] J A Π r  
[PipeFill In Progress] F i L L  
[InPres Comp Active] i P P C  
[Sleep Active] S L Π  
[Priming pump running] P P o n  
[Jockey pump running] J P o n  
[Sleep Boost active] S L P b  
[Sleep Checking activated] A S L C  
[Set 1 active] C F P 1  
[Set 2 active] C F P 2  
[Set 3 active] C F P 3  
[PID Active] A u t o  
[DC Bus Charged] d b L  
[Fast stop Active] F S t  
[Fallback Frequency] F r F  
[Speed Maintained] r L S  
[Type of stop] S t t  
[Frequency ref. att.] S r A  
[Forward] Π F r d  
[Reverse] Π r r S  
[In motor fluxing] F L X  
[Autotuning] t u n

---

## [Diagnostics] *d R U* - Menu

### Access

[Diagnostics] → [Diag. data] → [Diagnostics]

### About This Menu

This menu allows to make simple test sequences for diagnostics.

### [FAN Diagnostics] *F n t*

Diagnostics of internal fan(s).

This will start a test sequence.

### [HMI LED Diagnostics] *H L t*

Diagnostics of product LED(s).

This will start a test sequence.

### [IGBT Diag w motor] *i W t*

Diagnostics of product IGBT(s).

This will start a test sequence with the connected motor (open circuit/short-circuit).

### [IGBT Diag w/o motor] *i W o t*

Diagnostics of product IGBT(s).

This will start a test sequence without the motor (short-circuit).

## [Identification] - Menu

### Access

[Diagnostics] → [Diag. data] → [Identification]

### About This Menu

This is a read-only menu that cannot be configured. It enables the following information to be displayed:

- Drive reference, power rating, and voltage
- Drive software version
- Drive serial number
- Type of option modules present, with their software version
- Graphic Display Terminal type and version

## Section 5.2

### [Error history]

#### [Error history] P F H - Menu

##### Access

[Diagnostics] → [Error history]

##### About This Menu

This menu shows the 15 last detected errors (*d P I* to *d P F*).

Pressing OK key on the selected error code in the Error history list displays the drive data recorded when the error has been detected.

**NOTE:** Same content for [Last Error 1] *d P I* to [Last Error F] *d P F*.

##### [Last Error 1] *d P I*

Last error 1.

Identical to [Last Error] *L F E* (see page 70).

##### [Drive State] *H S I*

HMI status.

Setting	Code / Value	Description
[Autotuning]	<i>t u n</i>	Autotuning
[In DC inject.]	<i>d C b</i>	Injection braking
[Ready]	<i>r d Y</i>	Drive ready
[Freewheel]	<i>n S t</i>	Freewheel stop
[Drv running]	<i>r u n</i>	Motor in steady state or run command present and zero reference
[Accelerating]	<i>A C C</i>	Accelerating
[Decelerating]	<i>d E C</i>	Decelerating
[Current lim.]	<i>C L i</i>	Current limit
[Fast stop]	<i>F S t</i>	Fast stop
[Motor fluxing]	<i>F L u</i>	Fluxing function is activated
[no mains V.]	<i>n L P</i>	Control is powered on but the DC bus is not loaded
[control.stop]	<i>C t L</i>	Controlled stop
[Dec. adapt.]	<i>a b r</i>	Adapted deceleration
[Output cut]	<i>S o C</i>	Stand by output cut
[UnderV. al.]	<i>u S R</i>	Undervoltage warning
[Operating State Fault]	<i>F L t</i>	Operating state fault
[DCP Flashing Mode]	<i>d C P</i>	DCP flashing mode
[STO active]	<i>S t o</i>	Safe Torque Off active
[Idle State]	<i>i d L E</i>	Idle state

##### [Last Error 1 Status] *E P I*

Status of last error 1.

DRIVECOM status register (same as [ETA state word] *E t R*).

**[ETI state word] , P I**

ETI state word.  
 ETI status register (see the communication parameter file).

**[Cmd word] C P P I**

Cmd word.  
 Command register (same as **[Cmd word] C P d**).

**[Motor current] L C P I**

Motor current (same as **[Motor Current] L C r**).

Setting	Description
-3,276.7...3,276.7 A	Setting range <b>Factory setting:</b> _

**[Output frequency] r F P I**

Output frequency (same as **[Output frequency] r F r**).

Setting	Description
-3,276.7...3,276.7 Hz	Setting range <b>Factory setting:</b> _

**[Elapsed Time] r t P I**

Elapsed time.

Setting	Description
0...65,535 h	Setting range <b>Factory setting:</b> _

**[Mains Voltage] u L P I**

Mains voltage (same as **[Mains Voltage] u L n**).

Setting	Description
0...6,553.5 V	Setting range <b>Factory setting:</b> _

**[Motor therm state] t H P I**

Motor thermal state (same as **[Motor Therm state] t H r**).

Setting	Description
0...65,535%	Setting range <b>Factory setting:</b> _

**[Command Channel] d C C I**

Command channel (same as **[Command channel] C P d C**).

Setting	Code / Value	Description
<b>[Terminals]</b>	t E r P	Terminal block
<b>[HMI]</b>	H P i	Graphic Display Terminal
<b>[Modbus]</b>	P d b	Modbus serial
<b>[CANopen]</b>	C P n	CANopen
<b>[Com. Module]</b>	n E t	Fieldbus module
<b>[Ethernet Module]</b>	E t h	Embedded Ethernet

**[Ref Freq Channel] d r C I**

Channel for reference frequency (same as **[Ref Freq Channel] r F C C**).

Identical to **[Command channel] d C C I** (see page 78).

**[Motor Torque] o t P I**

Estimated motor torque value (same as **[Motor Torque] o t r**).

Setting	Description
-3,276.7...3,276.7%	Setting range Factory setting: _

**[Drive Thermal State] t d P I**

Measured drive thermal state (same as **[Drive Therm State] t H d**).

Setting	Description
0...355%	Setting range Factory setting: _

**[IGBT Junction Temp] t J P I**

Estimated junction temperature value.

Setting	Description
0...255°C	Setting range Factory setting: _

**[Switching Frequency] S F P I**

Switching frequency applied (related to **[Switching Frequency] S F r**).

Setting	Description
0...65,535 Hz	Setting range Factory setting: _

**[Last Error 2] d P 2 to [Last Error F] d P F**

Last error 2... Last error F

Identical to **[Last Error1] d P I** (see page 77).

## Section 5.3

### [Warnings]

#### What Is in This Section?

This section contains the following topics:

Topic	Page
[Actual warnings] <i>AL r d</i> - Menu	81
[Warning group 1 definition] <i>R 1 C</i> - Menu	82
[Warning group 2 definition] <i>R 2 C</i> - Menu	83
[Warning group 3 definition] <i>R 3 C</i> - Menu	84
[Warning group 4 definition] <i>R 4 C</i> - Menu	85
[Warning group 5 definition] <i>R 5 C</i> - Menu	86
[Warnings] <i>AL r</i> - Menu	87



---

## [Actual warnings] *FLrd* - Menu

### Access

[Diagnostics] → [Warnings] → [Actual warnings]

### About This Menu

List of current warnings.

If a warning is active, ✓ and  appears on the Graphic Display Terminal.

### List of Available Warnings

Identical to [Last warning] *FLrL* (*see page 69*).

## [Warning group 1 definition] *R I C* - Menu

### Access

[Diagnostics] → [Warnings] → [Warning group 1 definition]

### About This Menu

The following submenus group the warnings into 1 to 5 groups, each of which can be assigned to a relay or a digital output for remote signaling.

When one or a number of warnings selected in a group occurs, this warning group is activated.

### List of Warnings

Identical to [Last warning] *L R L* (*see page 69*).

---

## [Warning group 2 definition] *A 2 C* - Menu

### Access

[Diagnostics] → [Warnings] → [Warning group 2 definition]

### About This Menu

Identical to [Warning group 1 definition] *A 1 C* (*see page 82*)

## [Warning group 3 definition] *A 3 C* - Menu

### Access

[Diagnostics] → [Warnings] → [Warning group 3 definition]

### About This Menu

Identical to [Warning group 1 definition] *A 1 C* (*see page 82*)

---

## [Warning group 4 definition] *R 4 C* - Menu

### Access

[Diagnostics] → [Warnings] → [Warning group 4 definition]

### About This Menu

Identical to [Warning group 1 definition] *R 1 C* (*see page 82*)

## **[Warning group 5 definition] R 5 C - Menu**

### **Access**

**[Diagnostics] → [Warnings] → [Warning group 5 definition]**

### **About This Menu**

Identical to **[Warning group 1 definition] R 1 C** (*see page 82*)

---

## [Warnings] *FLr* - Menu

### Access

[Diagnostics] → [Warnings]

### About This Menu

This menu presents the warning history (30 past warnings).

### [Warning History] *FLH*

Identical to [Last warning] *FLrL* (*see page 69*).





---

# Chapter 6

## [Display] Π ο η -

---

### Introduction



**[Display] Π ο η -** menu shows monitoring data related to the drive and the application.

It offers an application-oriented display in terms of energy, cost, cycle, efficiency, ...

This is available with customized units and graphics view.

### What Is in This Chapter?

This chapter contains the following sections:

Section	Topic	Page
6.1	[Energy parameters]	90
6.2	[Application parameters]	98
6.3	[Pump parameters]	101
6.4	[Motor parameters]	108
6.5	[Drive parameters]	110
6.6	[Thermal monitoring]	112
6.7	[PID display]	113
6.8	[Counter management]	114
6.9	[Other state]	116
6.10	[I/O map]	117
6.11	[Communication map]	134
6.12	[Data logging]	157

---

## Section 6.1

### [Energy parameters]

---

#### What Is in This Section?

This section contains the following topics:

Topic	Page
[Elec Ener Input Counter] $E L \uparrow$ - Menu	91
[Elec Ener Output Counter] $E L \downarrow$ - Menu	93
[Mechanical energy] $\Pi E C$ - Menu	95
[Energy saving] $E S \#$ - Menu	97

## [Elec Ener Input Counter] $E L$ , - Menu

### Access

[Display] → [Energy parameters] → [Elec Ener Input Counter]

### About This Menu

This menu presents the input electrical energy data.

### [Active Input Power] $P r W$

Active electrical input power estimation.

Setting	Description
According to the drive rating	Setting range in kW if [Motor Standard] $b F r$ is set to [50Hz IEC] $5 D$ or in HP if [Motor Standard] $b F r$ is set to [60Hz NEMA] $6 D$ Factory setting: _

### [Real Input Energy(Wh)] $E D$ ★

Input electrical power consumed (Wh).

This parameter can be accessed if:

- [Real Input Energy(TWh)]  $E 4$ ,
- [Real Input Energy(GWh)]  $E 3$ ,
- [Real Input Energy(MWh)]  $E 2$ , and
- [Real Input Energy(kWh)]  $E 1$  are set to 0.

Setting	Description
-999...999 Wh	Setting range Factory setting: _

### [Real Input Energy(kWh)] $E 1$ ★

Input electrical power consumed (kWh).

This parameter can be accessed if:

- [Real Input Energy(TWh)]  $E 4$ , [Real Input Energy(GWh)]  $E 3$  and [Real Input Energy(MWh)]  $E 2$  are set to 0, and
- [Real Input Energy(kWh)]  $E 1$  is not set to 0.

Setting	Description
-999...999 kWh	Setting range Factory setting: _

### [Real Input Energy(MWh)] $E 2$ ★

Input electrical power consumed (MWh).

This parameter can be accessed if:

- [Real Input Energy(TWh)]  $E 4$  and [Real Input Energy(GWh)]  $E 3$  are set to  $D$ , and
- [Real Input Energy(MWh)]  $E 2$  is not set to 0

Setting	Description
-999...999 MWh	Setting range Factory setting: _

**[Real Input Energy(GWh)] , E 3 ★**

Input electrical power consumed (GWh).

This parameter can be accessed if:

- **[Real Input Energy(TWh)] , E 4** is set to 0, and
- **[Real Input Energy(GWh)] , E 3** is not set to 0.

Setting	Description
-999...999 GWh	Setting range Factory setting: _

**[Real Input Energy(TWh)] , E 4 ★**

Input electrical power consumed (TWh).

This parameter can be accessed if **[Real Input Energy(TWh)] , E 4** is not set to 0.

Setting	Description
-999...999 TWh	Setting range Factory setting: _

## [Elec Ener Output Counter] *E L 0* - Menu

### Access

[Display] → [Energy parameters] → [Elec Ener Output Counter]

### About This Menu

This menu presents the output electrical energy data.

### [Acv Elc out pwr estm] *E P r W*

Active electrical output power estimation.

### [Real Consumption(Wh)] *0 E 0* ★

Electrical energy consumed (Wh).

This parameter can be accessed if:

- [Real Consumption(TWh)] *0 E 4*,
- [Real Consumption(GWh)] *0 E 3*,
- [Real Consumption (MWh)] *0 E 2*, and
- [Real Consumption (kWh)] *0 E 1* are set to 0.

### [Real Consumption(kWh)] *0 E 1* ★

Electrical energy consumed (kWh).

This parameter can be accessed if:

- [Real Consumption(TWh)] *0 E 4*, [Real Consumption(GWh)] *0 E 3* and [Real Consumption(MWh)] *0 E 2* are set to 0, and
- [Real Consumption(kWh)] *0 E 1* is not set to 0.

Setting	Description
-999...999 kWh	Setting range Factory setting: _

### [Real Consumption(MWh)] *0 E 2* ★

Electrical energy consumed (MWh).

This parameter can be accessed if:

- [Real Consumption(TWh)] *0 E 4* and [Real Consumption(GWh)] *0 E 3* are set to 0, and
- [Real Consumption(MWh)] *0 E 2* is not set to 0.

Setting	Description
-999...999 MWh	Setting range Factory setting: _

### [Real Consumption(GWh)] *0 E 3* ★

Electrical energy consumed (GWh).

This parameter can be accessed if:

- [Real Consumption(TWh)] *0 E 4* is set to 0, and
- [Real Consumption(GWh)] *0 E 3* is not set to 0.

Setting	Description
-999...999 GWh	Setting range Factory setting: _

**[Real Consumption(TWh)]  $\alpha E 4$  ★**

Electrical energy consumed (TWh).

This parameter can be accessed if **[Real Consumption(TWh)]  $\alpha E 4$**  is not set to 0.

Setting	Description
-999...999 TWh	Setting range <b>Factory setting:</b> _

**[Elc Egy Today]  $\alpha C t$**

Electrical energy consumed today by the motor (kWh).

Setting	Description
0...4,294,967,295 kWh	Setting range <b>Factory setting:</b> _

**[Elc Egy Yesterday]  $\alpha C y$**

Electrical energy consumed yesterday by the motor (kWh).

Setting	Description
0...4,294,967,295 kWh	Setting range <b>Factory setting:</b> _

**[Over-Consumption Thd]  $P C R H$**

Power level for over-consumption.

Setting	Description
<b>[Under-Consumption Thd]</b> $P C R L$ ...200.0%	Setting range <b>Factory setting:</b> 0.0%

**[Under-Consumption Thd]  $P C R L$**

Power level for under-consumption.

Maximum value =  $P C R H$  if  $P C R H \leq 100\%$ .

Setting	Description
0.0...100.0% or <b>[Over-Consumption Thd] <math>P C R H</math></b> if $P C R H \leq 100\%$	Setting range <b>Factory setting:</b> 0.0%

**[Over/Under-Cons Delay]  $P C R t$**

Over/under-consumption detection time.

Setting	Description
0...60 min	Setting range <b>Factory setting:</b> 1 min

**[Peak Output Power]  $\Pi \alpha E P$**

Peak output power.

Setting	Description
According to the drive rating	Setting range <b>Factory setting:</b> _

## [Mechanical energy] П E C - Menu

### Access

[Display] → [Energy parameters] → [Mechanical energy]

### About This Menu

This menu presents the output mechanical energy data.

### [Power Estim Value] □ P r W

Motor mechanical power estimation.

### [Motor Consumption (Wh)] П E D ★

Energy consumption (Wh).

This parameter can be accessed if:

- [Motor Consumption(TWh)] П E Ч,
- [Motor Consumption(GWh)] П E Э,
- [Motor Consumption(MWh)] П E З, and
- [Motor Consumption(kWh)] П E I are set to 0.

Setting	Description
0...999 Wh	Setting range Factory setting: _

### [Motor Consumption(kWh)] П E I ★

Energy consumption (kWh).

This parameter can be accessed if:

- [Motor Consumption(TWh)] П E Ч, [Motor Consumption(GWh)] П E Э and [Motor Consumption(MWh)] П E З are set to 0, and
- [Motor Consumption(kWh)] П E I is not set to 0.

Setting	Description
0...999 kWh	Setting range Factory setting: _

### [Motor Consumption(MWh)] П E З ★

Energy consumption (MWh).

This parameter can be accessed if:

- [Motor Consumption(TWh)] П E Ч and [Motor Consumption(GWh)] П E Э are set to 0, and
- [Motor Consumption(MWh)] П E З is not set to 0.

Setting	Description
0...999 MWh	Setting range Factory setting: _

**[Motor Consumption(GWh)] П E Э ★**

Energy consumption (GWh).

This parameter can be accessed if:

- **[Motor Consumption(TWh)] П E Ч** is set to 0, and
- **[Motor Consumption(GWh)] П E Э** is not set to 0.

Setting	Description
0...999 GWh	Setting range Factory setting: _

**[Motor Consumption(TWh)] П E Ч ★**

Energy consumption (TWh).

This parameter can be accessed if **[Motor Consumption(TWh)] П E Ч** is not set to 0.

Setting	Description
0...999 TWh	Setting range Factory setting: _



## [Energy saving] *E 5 R* - Menu

### Access

[Display] → [Energy parameters] → [Energy saving]

### About This Menu

This menu presents the comparison in term of cost, energy, CO<sup>2</sup> between solutions with and without drive.

### [Reference Power] *P<sub>r</sub> E F*

Reference electrical power for a solution without drive.

Setting	Description
0.00...655.35 kW	Setting range in kW if <b>[Motor Standard] b F r</b> is set to <b>[50Hz IEC] 5 D</b> or in HP if <b>[Motor Standard] b F r</b> is set to <b>[60Hz NEMA] 5 D</b> . <b>Factory setting:</b> 0.00 kW

### [kWh Cost] *E C 5 t*

Cost of the kWh.

Setting	Description
0.00...42,949,672.95 \$	Setting range in € if <b>[Motor Standard] b F r</b> is set to <b>[50 Hz IEC] (50)</b> or in \$ if <b>[Motor Standard] b F r</b> is set to <b>[60Hz NEMA] 5 D</b> . <b>Factory setting:</b> _

### [CO<sub>2</sub> Ratio] *E C o 2*

Quantity of CO<sup>2</sup> by kWh.

Setting	Description
0.000...65.535 kg/kWh	Setting range <b>Factory setting:</b> 0.000 kg/kWh

### [Energy Saved] *E 5 R u*

Energy saved with the drive solution.

Setting	Description
0...4,294,967,295 kWh	Setting range <b>Factory setting:</b> _

### [Money Saved] *C A 5 H*

Cost saved with the drive solution.

Setting	Description
0.00...42,949,672.95 \$	Setting range in € if <b>[Motor Standard] b F r</b> is set to <b>[50 Hz IEC] 5 D</b> or in \$ if <b>[Motor Standard] b F r</b> is set to <b>[60 Hz NEMA] 5 D</b> . <b>Factory setting:</b> _

### [Co<sub>2</sub> Saved] *C o 2 5*

CO<sup>2</sup> saved with the drive solution.

Setting	Description
0.0...429,496,729.5 t	Setting range <b>Factory setting:</b> _

## Section 6.2

### [Application parameters]

#### [Application parameters] *APP* - Menu

##### Access

[Display] → [Application parameters]

##### About This Menu

This menu displays information related to the application.

#### [Application State] *APP5*

Application state.

Setting	Code / Value	Description
[Running]	<i>r u n</i>	No application function in progress; the drive is running
[Stop]	<i>S t o p</i>	No application function in progress; the drive is not running
[Local Mode Active]	<i>L o c a l</i>	Forced local mode activated
[Channel 2 Active]	<i>o u e r</i>	Override speed control mode activated
[Manual Mode Active]	<i>Π A n u</i>	Motor running; manual PID mode is active
[PID Active]	<i>A u t o</i>	Motor running; auto PID mode is active
[Antijam In Progress]	<i>A J A Π</i>	The Anti-jam is in progress
[Flow Limit In Progress]	<i>F L , Π</i>	The flow limitation is in progress
[PipeFill In Progress]	<i>F , L L</i>	The pipe fill is in progress
[Jockey Pump Active]	<i>J o c k e y</i>	The jockey pump is active
[Boost In progress]	<i>b o o s t</i>	The boost is in progress
[Sleep Active]	<i>S L E E P</i>	The sleep is active
[Priming Pump Active]	<i>P r , Π</i>	The priming pump is active
[InletPres Comp In Progress]	<i>C o Π P</i>	The inlet pressure compensation is in progress

**[Booster Status] b c 5 ★**

Booster status.

This parameter can be accessed if **[Application Selection] A P P L** is set to **[Pump Booster Control] b o o 5 t**.

Setting	Code / Value	Description
[None]	n o n E	Not configured
[Inactive]	n A c t	Inactive
[Running]	r u n	Running
[Stage Pending]	S t G P	Stage pending
[Destage Pending]	d S t G P	Destage pending
[Staging]	S t G	Staging
[Destaging]	d S t G	Destage in progress

**[LevelCtrl Status] L c 5 ★**

Level control status.

This parameter can be accessed if **[Application Selection] A P P L** is set to **[Pump Level Control] L E V E L**.

Setting	Code / Value	Description
[None]	n o n E	Not configured
[Inactive]	n A c t	Inactive
[Filling]	F , L L	Filling in progress
[Emptying]	E P P E Y	Emptying in progress
[Low Level]	L o w _ L E V E L	Low level
[High Level]	h , G h _ L E V E L	High level

**[Tank Level] L c t L ★**

Tank level.

This parameter can be accessed if **[Application Selection] A P P L** is set to **[Pump Level Control] L E V E L**.

Setting	Description
0.0...100.0%	Setting range Factory setting: –

**[Level Sensor Value] L c 5 v ★**

Level sensor value.

This parameter can be accessed if **[Level Sensor Assign] L c 5 A** is set to **[Not configured] n o**.

Setting	Description
-327.67...327.67	Setting range Factory setting: –

**[PID Reference] r P c ★**

PID reference.

This parameter can be accessed if **[PID Feedback] P , F** is set to **[Not Configured] n o**.

Setting	Description
0...65,535%	Setting range Factory setting: –

**[Installation Flow] F 5 I U**

Flow rate sensor value.

Setting	Description
-32,767...32,767	Setting range <b>Factory setting:</b> –

**[Inlet Press. Value] P 5 I U**

Inlet pressure value.

Setting	Description
-32,767...32,767	Setting range <b>Factory setting:</b> –

**[Outlet Pressure] P 5 P U**

Outlet pressure value.

Setting	Description
-32,767...32,767	Setting range <b>Factory setting:</b> –

**[Total Quantity] F 5 I C**

Total quantity.

Setting	Description
-2,147,483,647...2,147,483,647	Setting range <b>Factory setting:</b> –

**[Highest Flow] F 5 I K**

Highest flow.

Setting	Description
-32,767...32,767	Setting range <b>Factory setting:</b> –

**[Lowest Flow] F 5 I J**

Lowest flow.

Setting	Description
-32,767...32,767	Setting range <b>Factory setting:</b> –

---

## Section 6.3

### [Pump parameters]

---

#### What Is in This Section?

This section contains the following topics:

Topic	Page
[Variable speed pump] $\Pi P P$ - Menu	102
[Multipump system] $\Pi P S$ - Menu	104

## [Variable speed pump] $\Pi P P$ - Menu

### Access

[Display] → [Pump parameters] → [Variable speed pump]

### About This Menu

This menu shows the pump-related parameters.

### [Motor Run Time] $r t H$

Motor run time.

Run elapsed time display (resettable) in seconds, minutes, or hours (length of time the motor has been switched on).

Setting	Description
0...4,294,967,295 s	Setting range Factory setting: _

### [Motor Mechanical speed] $5 P d \Pi$

Motor mechanical speed.

Setting	Description
0...65,535 rpm	Setting range Factory setting: _

### [Nb Of Start] $n 5 \Pi$

Number of motor starts.

Setting	Description
0...4,294,967,295	Setting range Factory setting: _

### [Acv Elc out pwr estm] $E P r W$

Active electrical output power estimation.

Setting	Description
-327.67...327.67 kW	Setting range Factory setting: _

### [Pump Flow] $F 5 2 \cup$ ★

Pump flow value.

This parameter can be accessed if [Pump Flow Assign.]  $F 5 2 R$  is set to [Not Configured]  $n o$ .

Setting	Description
-32,767...32,767	Setting range Factory setting: -

### [Inlet Press. Value] $P 5 I \cup$ ★

Inlet pressure value.

This parameter can be accessed if [Pump Flow Assign.]  $F 5 2 R$  is set to [Not Configured]  $n o$ .

Setting	Description
-32,767...32,767	Setting range Factory setting: -

**[Outlet Pressure] P 5 2 U ★**

Outlet pressure.

This parameter can be accessed if **[Pump Flow Assign.] F 5 2 R** is set to **[Not Configured] n o**.

Setting	Description
-32,767...32,767	Setting range Factory setting: –

**[Efficiency] E F Y**

Efficiency.

Setting	Description
0...65,535	Setting range Factory setting: _

**[Energy Cons. Ind.] E C I**

Energy consumption indicator.

Setting	Description
-32,767...32,767	Setting range Factory setting: –

**[Energy Perf. Ind] E P I**

Energy performance indicator.

Setting	Description
-32,767...32,767	Setting range Factory setting: –

**[Highest Eff.] E F Y K**

Highest efficiency.

Setting	Description
0...65,535	Setting range Factory setting: _

**[Lowest Eff.] E F Y J**

Lowest efficiency.

Setting	Description
0...65,535	Setting range Factory setting: _

## [Multipump system] *MP5* - Menu

### Access

[Display] → [Pump parameters] → [Multipump system]

### About This Menu

This menu can be accessed if [Pump System Architecture] *MP5A* is not set to [No] *no*.

### [MultiPump State] *MP5*

Multipump function state.

Setting	Code / Value	Description
[None]	<i>none</i>	None
[Ready]	<i>READY</i>	Ready
[Running]	<i>run</i>	Running
[Warning]	<i>ALARM</i>	Warning
[Error]	<i>FULL</i>	Error

### [Available Pumps] *MPAn*

Number of available pumps.

Setting	Description
0...65,535	Setting range Factory setting: –

### [Nb of Staged Pumps] *MP5n*

Number of staged pumps.

Setting	Description
0...65,535	Setting range Factory setting: –

### [Lead Pump] *PLid*

Lead pump.

Setting	Code / Value	Description
[None]	<i>none</i>	None
[Pump 1]	<i>P01</i>	Pump number 1
[Pump 2]	<i>P02</i>	Pump number 2
[Pump 3]	<i>P03</i>	Pump number 3
[Pump 4]	<i>P04</i>	Pump number 4
[Pump 5]	<i>P05</i>	Pump number 5
[Pump 6]	<i>P06</i>	Pump number 6

### [Next Staged Pump] *Pnt5*

Next pump to stage.

Identical to [Lead Pump] *PLid* (see page 104).

### [Next Destaged Pump] *Pntd*

Next pump to destage.

Identical to [Lead Pump] *PLid* (see page 104).



**[Pump 1 State] P 15 ★**

Pump 1 state.

This parameter can be accessed if **[Nb Of Pumps] Π P P n** is not set 1 or higher.

Setting	Code / Value	Description
[None]	n o n E	Not configured
[Not Available]	n A v A i l	Unavailable
[Ready]	r e d y	Ready
[Running]	r u n	Running

**[Pump 1 Type] P 1 E ★**

Pump 1 type.

This parameter can be accessed if **[Nb Of Pumps] Π P P n** is not set 1 or higher.

Setting	Code / Value	Description
[None]	n o n E	Undefined
[Lead]	L E A d	Lead pump
[Lead or Auxiliary]	L A F	Lead or auxiliary fixed speed pump
[Lead or Auxiliary Variable]	L A V	Lead or auxiliary variable speed pump
[Auxiliary]	A u X F	Auxiliary fixed speed pump
[Auxiliary Variable]	A u X V	Auxiliary variable speed pump
[Error]	E r r	Error

**[Pump 1 Runtime] P 1 o E ★**

Pump 1 running time.

This parameter can be accessed if **[Nb Of Pumps] Π P P n** is not set 1 or higher.

Setting	Description
0...4,294,967,295 s	Setting range <b>Factory setting:</b> –

**[Pump 1 Nb Starts] P 1 n 5 ★**

Pump 1 number of starts.

This parameter can be accessed if **[Nb Of Pumps] Π P P n** is not set 1 or higher.

Setting	Description
0...4,294,967,295 s	Setting range <b>Factory setting:</b> –

**[Pump 2 State] P 2 5 ★**

Pump 2 state.

This parameter can be accessed if **[Nb Of Pumps] Π P P n** is not set 2 or higher.

Identical to **[Pump 1 State] P 1 5** ([see page 105](#)).

**[Pump 2 Type] P 2 E ★**

Pump 2 type.

This parameter can be accessed if **[Nb Of Pumps] Π P P n** is not set 2 or higher.

Identical to **[Pump 1 Type] P 1 E** ([see page 105](#)).

**[Pump 2 Runtime] P 2 o t ★**

Pump 2 running time.

This parameter can be accessed if **[Nb Of Pumps] n P P n** is not set 2 or higher.

Identical to **[Pump 1 Runtime] P 1 o t** (*see page 105*).

**[Pump 2 Nb Starts] P 2 n S ★**

Pump 2 number of starts.

This parameter can be accessed if **[Nb Of Pumps] n P P n** is not set 2 or higher.

Identical to **[Pump 1 Nb Starts] P 1 n S** (*see page 105*).

**[Pump 3 State] P 3 S ★**

Pump 3 state.

This parameter can be accessed if **[Nb Of Pumps] n P P n** is not set 3 or higher.

Identical to **[Pump 1 State] P 1 S** (*see page 105*).

**[Pump 3 Type] P 3 t ★**

Pump 3 type.

This parameter can be accessed if **[Nb Of Pumps] n P P n** is not set 3 or higher.

Identical to **[Pump 1 Type] P 1 t** (*see page 105*).

**[Pump 3 Runtime] P 3 o t ★**

Pump 3 running time.

This parameter can be accessed if **[Nb Of Pumps] n P P n** is not set 3 or higher.

Identical to **[Pump 1 Runtime] P 1 o t** (*see page 105*).

**[Pump 3 Nb Starts] P 3 n S ★**

Pump 3 number of starts.

This parameter can be accessed if **[Nb Of Pumps] n P P n** is not set 3 or higher.

Identical to **[Pump 1 Nb Starts] P 1 n S** (*see page 105*).

**[Pump 4 State] P 4 S ★**

Pump 4 state.

This parameter can be accessed if **[Nb Of Pumps] n P P n** is not set 4 or higher.

Identical to **[Pump 1 State] P 1 S** (*see page 105*).

**[Pump 4 Type] P 4 t ★**

Pump 4 type.

This parameter can be accessed if **[Nb Of Pumps] n P P n** is not set 4 or higher.

Identical to **[Pump 1 Type] P 1 t** (*see page 105*).

**[Pump 4 Runtime] P 4 o t ★**

Pump 4 running time.

This parameter can be accessed if **[Nb Of Pumps] n P P n** is not set 4 or higher.

Identical to **[Pump 1 Runtime] P 1 o t** (*see page 105*).

**[Pump 4 Nb Starts] P 4 n 5 ★**

Pump 4 number of starts.

This parameter can be accessed if **[Nb Of Pumps] Π P P n** is not set 4 or higher.

Identical to **[Pump 1 Nb Starts] P 1 n 5** (*see page 105*).

**[Pump 5 State] P 5 S ★**

Pump 5 state.

This parameter can be accessed if **[Nb Of Pumps] Π P P n** is not set 5 or higher.

Identical to **[Pump 1 State] P 1 S** (*see page 105*).

**[Pump 5 Type] P 5 T ★**

Pump 5 type.

This parameter can be accessed if **[Nb Of Pumps] Π P P n** is not set 5 or higher.

Identical to **[Pump 1 Type] P 1 T** (*see page 105*).

**[Pump 5 Runtime] P 5 o T ★**

Pump 5 running time.

This parameter can be accessed if **[Nb Of Pumps] Π P P n** is not set 5 or higher.

Identical to **[Pump 1 Runtime] P 1 o T** (*see page 105*).

**[Pump 5 Nb Starts] P 5 n 5 ★**

Pump 5 number of starts.

This parameter can be accessed if **[Nb Of Pumps] Π P P n** is not set 5 or higher.

Identical to **[Pump 1 Nb Starts] P 1 n 5** (*see page 105*).

**[Pump 6 State] P 6 S ★**

Pump 6 state.

This parameter can be accessed if **[Nb Of Pumps] Π P P n** is not set 6 or higher.

Identical to **[Pump 1 State] P 1 S** (*see page 105*).

**[Pump 6 Type] P 6 T ★**

Pump 6 type.

This parameter can be accessed if **[Nb Of Pumps] Π P P n** is not set 6 or higher.

Identical to **[Pump 1 Type] P 1 T** (*see page 105*).

**[Pump 6 Runtime] P 6 o T ★**

Pump 6 running time.

This parameter can be accessed if **[Nb Of Pumps] Π P P n** is not set 6 or higher.

Identical to **[Pump 1 Runtime] P 1 o T** (*see page 105*).

**[Pump 6 Nb Starts] P 6 n 5 ★**

Pump 6 number of starts.

This parameter can be accessed if **[Nb Of Pumps] Π P P n** is not set 6 or higher.

Identical to **[Pump 1 Nb Starts] P 1 n 5** (*see page 105*).

## Section 6.4

### [Motor parameters]

#### [Motor parameters] ▸ ▸ ▸ - Menu

##### Access

[Display] → [Motor parameters]

##### About This Menu

This menu shows the motor-related parameters.

#### [Motor Speed] *S P d*

Motor speed.

Setting	Description
0...65,535 krpm	Setting range Factory setting: _

#### [Motor Voltage] *u o P*

Motor voltage.

Setting	Description
0...65,535 V	Setting range Factory setting: _

#### [Motor Power] *o P r*

Motor power.

Output power monitoring (100% = nominal motor power).

Setting	Description
-300.00...300.00%	Setting range Factory setting: _

#### [Motor Torque] *o t r*

Motor torque.

Output torque value (100% = nominal motor torque).

Setting	Description
-300.00...300.00%	Setting range Factory setting: _

**[Motor Current] L C r**

Motor current.

Setting	Description
0.00...655.35 A	Setting range Factory setting: _

**[Motor Therm state] L H r**

Motor thermal state.

The normal motor thermal state is 100%, the **[Motor Overload] o L F** is set to 118%.

Setting	Description
0.00...200.00%	Setting range Factory setting: _

## Section 6.5

### [Drive parameters]

#### [Drive parameters] $\Pi P$ , - Menu

##### Access

[Display] → [Drive parameters]

##### About This Menu

This menu shows the drive-related parameters.

#### [Image Input AIV1] $\Pi I V 1$

Virtual analog input value.

This parameter is read-only. It enables you to display the speed reference applied to the motor via the fieldbus channel.

Setting $\odot$	Description
-8,192...8,192	Setting range <b>Factory setting:</b> _

#### [Pre-Ramp Ref Freq] $\Pi R F H$

Frequency reference before ramp.

This parameter is read-only. It enables you to display the speed reference applied to the motor, regardless of which reference channel has been selected.

Setting	Description
-500.0...500.0 Hz	Setting range <b>Factory setting:</b> _

#### [Ref Frequency] $L F r$

Reference frequency.

This parameter only appears if the function has been enabled. It is used to change the speed reference from the remote control. OK does not have to be pressed to enable a change of reference.

Setting $\odot$	Description
-500.0...500.0 Hz	Setting range <b>Factory setting:</b> 0.0 Hz

#### [Motor Frequency] $r F r$

Motor frequency.

Setting	Description
-3,276.7...3,276.7 Hz	Setting range <b>Factory setting:</b> 0.0 Hz

**[Multiplying Coeff.]** *Π F r* ★

Multiplying coefficient.

It can be accessed if **[Ref Freq - Multiply]** *Π A 2, Π A 3* has been assigned.

Setting ( )	Description
0...100%	Setting range Factory setting: _

**[Mains Voltage]** *υ L n*

Mains voltage based on DC bus measurement, motor running or stopped.

Setting	Description
1.0...860.0 Vdc	Setting range Factory setting: _

**[DC Bus Voltage]** *υ b u 5*

DC bus voltage.

Setting	Description
0...65,535	Setting range Factory setting: _

**[Drive Therm State]** *ε H d*

Drive thermal state.

The normal drive thermal state is 100%, the **[Motor Overload]** *ο L F* is set to 118%.

Setting	Description
0...200%	Setting range Factory setting: _

**[Used Param. Set]** *ε F P 5* ★

Used parameter set.

Configuration parameter status (can be accessed if parameter switching has been enabled).

Setting	Code / Value	Description
[None]	<i>η ο</i>	Not assigned
[Set N°1]	<i>ε F P 1</i>	Parameter set 1 active
[Set N°2]	<i>ε F P 2</i>	Parameter set 2 active
[Set N°3]	<i>ε F P 3</i>	Parameter set 3 active

## Section 6.6

### [Thermal monitoring]

#### [Thermal monitoring] $\text{E P } \Pi$ - Menu

##### Access

[Display] → [Thermal monitoring]

##### About This Menu

The content of this menu can be accessed if the thermal monitoring function has been activated.

##### Wiring

Refer to the wiring (*see page 466*) of the [Pump thermal monit]  $\text{E P } P$  - menu.

#### [AI2 Th Value] $\text{E H } 2 \text{ U}$ ★

AI2 thermal value.

Setting	Description
-15...200°C	Setting range Factory setting: –

#### [AI3 Th Value] $\text{E H } 3 \text{ U}$ ★

AI3 thermal value.

Identical to [AI2 Th Value]  $\text{E H } 2 \text{ U}$ .

#### [AI4 Th Value] $\text{E H } 4 \text{ U}$ ★

AI4 thermal value.

Identical to [AI2 Th Value]  $\text{E H } 2 \text{ U}$ .

This parameter can be accessed if VW3A3203 I/O extension module has been inserted.

#### [AI5 Th Value] $\text{E H } 5 \text{ U}$ ★

AI5 thermal value.

Identical to [AI2 Th Value]  $\text{E H } 2 \text{ U}$ .

This parameter can be accessed if VW3A3203 I/O extension module has been inserted.



## Section 6.7

### [PID display]

#### [PID display] $P_i C$ - Menu

##### Access

[Display] → [PID display]

##### About This Menu

**NOTE:** This function cannot be used with some other functions. Follow the instructions about the compatibility of functions.

Following parameters can be accessed if [PID feedback]  $P_i F$  is not set to [Not Configured]  $n o$ .

#### [Internal PID ref] $r P_i \star$

Internal PID reference.

Setting 	Description
0...32,767	Setting range Factory setting: 150

#### [PID Reference] $r P C \star$

PID setpoint value.

Setting	Description
0...65,535	Setting range Factory setting: 0

#### [PID feedback] $r P F \star$

PID feedback value.

Setting	Description
0...65,535	Setting range Factory setting: 0

#### [PID Error] $r P E \star$

PID error value.

Setting	Description
-32,767...32,767	Setting range Factory setting: –

#### [PID Output] $r P o \star$

PID output value.

Setting	Description
[PID Min Output] $P o L$ ... [PID Max Output] $P o h$	Setting range Factory setting: _

## Section 6.8

### [Counter management]

#### [Counter Management] *E L E* - Menu

##### Access

[Display] → [Counter Management]

##### About This Menu

This menu shows the drive and motor-related counters.

##### [Motor Run Time] *r E H*

Motor run time.

Run elapsed time display (resettable) in seconds, minutes, or hours (length of time the motor has been switched on).

Setting	Description
0...4,294,967,295 s	Setting range Factory setting: _

##### [Power-on Time] *P E H*

Power-on time.

Setting	Description
0...4,294,967,295 s	Setting range Factory setting: _

##### [Fan Operation Time] *F P b E*

Fan operation time.

As soon as [Fan Operation Time] *F P b E* reach the predefined value of 45,000 hours, a warning [Fan Counter Warning] *F C E H* is triggered.

[Fan Operation Time] *F P b E* counter can be set to 0 by using the [Counter Reset] *r P r* parameter.

Setting	Description
0...50,000 h	Setting range Factory setting: _

##### [Nb Of Start] *n S H*

Number of motor starts.

Setting	Description
0...4,294,967,295	Setting range Factory setting: _

**[Time Counter Reset] r P r**

Time counter reset.

Setting ( )	Code / Value	Description
[No]	n a	No <b>Factory setting</b>
[Run Time Reset]	r t H	Run time reset
[Power ON Time Reset]	P t H	Power ON time reset
[Reset Fan Counter]	F t H	Reset fan counter
[Clear NSM]	n S n	Number of motor start
[Efficiency MAX]	E F Y K	Efficiency max
[Efficiency MIN]	E F Y J	Efficiency min
[Flow Rate MAX]	F S I K	Flow rate max
[Flow Rate MIN]	F S I J	Flow rate min
[Reset Total Quantity]	F S I C	Reset total quantity

## Section 6.9

### [Other state]

---

#### [Other state] 5 5 L - Menu

##### Access

[Display] → [Other state]

##### About This Menu

List of secondary states.

##### List

[Anti-Jam pending] *J A Π P*  
[Anti-Jam In Progress] *J A Π r*  
[PipeFill In Progress] *F i L L*  
[InPres Comp Active] *i P P C*  
[Sleep Active] *S L Π*  
[Priming pump running] *P P o n*  
[Jockey pump running] *J P o n*  
[Sleep Boost active] *S L P b*  
[Sleep Checking activated] *A S L C*  
[Set 1 active] *C F P 1*  
[Set 2 active] *C F P 2*  
[Set 3 active] *C F P 3*  
[PID Active] *A u t o*  
[DC Bus Charged] *d b L*  
[Fast stop Active] *F S t*  
[Fallback Frequency] *F r F*  
[Speed Maintained] *r L S*  
[Type of stop] *S t t*  
[In braking] *b r S*  
[Ref Freq Warning] *S r A*  
[Forward] *Π F r d*  
[Reverse] *Π r r S*  
[In motor fluxing] *F L X*  
[Autotuning] *t u n*

## Section 6.10

### [I/O map]

#### What Is in This Section?

This section contains the following topics:

Topic	Page
[Digital Input Map] <i>L , A</i> - Menu	118
[AI1] <i>A , 1 C</i> - Menu	119
[AI2] <i>A , 2 C</i> - Menu	121
[AI3] <i>A , 3 C</i> - Menu	122
[AI4] <i>A , 4 C</i> - Menu	123
[AI5] <i>A , 5 C</i> - Menu	124
[Digital output map] <i>L o A</i> - Menu	125
[AQ1] <i>A o 1 C</i> - Menu	126
[AQ2] <i>A o 2 C</i> - Menu	130
[DI5 frequency measured] <i>P F C 5</i> - Menu	131
[DI6 frequency measured] <i>P F C 6</i> - Menu	133

## [Digital Input Map] L , R - Menu

### Access

[Display] → [I/O map] → [Digital Input Map]

### About This Menu

This menu presents the state and assignment of digital inputs.

Read-only parameters, cannot be configured.

It is used to visualize the state of the digital inputs and Safe Torque Off inputs.

It displays all the functions that are assigned to the digital input in order to verify for multiple assignments.

If no functions have been assigned, **[No]** is displayed. Use the touch wheel to scroll through the functions.

**[AI1] R , I C - Menu****Access**

[Display] → [I/O map] → [Analog inputs image] → [AI1]

**[AI1] R , I C**

Physical value AI1.

AI1 customer image: value of analog input 1.

Setting	Description
-32,767...32,767	Setting range Factory setting: –

**NOTE:** The parameters [AI1 Assignment] R , I A, [AI1 min value] L , L I, [AI1 max value] L , H I and [AI1 filter] R , I F can be accessed on the Graphic Display Terminal by pressing the **OK** key on the [AI1] R , I C parameter.

**[AI1 Assignment] R , I A**

Analog input AI1 functions assignment.

Read-only parameter, cannot be configured. It displays all the functions associated with input AI1 in order to verify, for example, for compatibility problems.

If no functions have been assigned, [No] n o is displayed.

Setting	Code / Value	Description
[No]	n o	Not assigned
[AQ1 assignment]	A o 1	Analog output AQ1
[AQ2 assignment]	A o 2	Analog output AQ2
[Ref Freq Channel 1]	F r 1	Reference frequency channel 1 <b>Factory Setting</b>
[Ref Freq Channel 2]	F r 2	Reference frequency channel 2
[Ref Frequency 2 Summing]	S R 2	Reference frequency 2 summing
[PID Feedback]	P , F	PI controller feedback
[Subtract Ref Freq 2]	d R 2	Subtract reference frequency 2
[Manual PID Ref.]	P , n	Manual speed reference of the PID controller (auto-man)
[PID Ref Frequency]	F P ,	PID reference frequency
[Ref Frequency 3 Summing]	S R 3	Reference frequency 3 summing
[Ref Frequency 1B]	F r 1 b	Reference frequency 1B
[Subtract Ref Freq 2]	d R 3	Subtract reference frequency 3
[Forced local]	F L o C	Forced local reference source1
[Ref Frequency 2 multiplier]	n R 2	Reference frequency 2 multiplier
[Ref Frequency 3 multiplier]	n R 3	Reference frequency 3 multiplier
[Virtual AI1 Channel]	R , C 1	Virtual AI1 channel selector function
[InletPres Assign]	P S 1 A	Select the source of inlet pressure sensor
[OutletPres Assign]	P S 2 A	Select the source of outlet pressure sensor
[Inst Flow Assign]	F S 1 A	Select the source of installation flow sensor
[Pump Flow Assign]	F S 2 A	Select the source of pump flow sensor

**[AI1 min value] *u, L, I* ★**

AI1 minimum value.

AI1 voltage scaling parameter of 0%.

This parameter can be accessed if **[AI1 Type] *R, IE*** is set to **[Voltage] *ID, u***.

Setting	Description
0.0...10.0 Vdc	Setting range <b>Factory setting:</b> 0.0 Vdc

**[AI1 max value] *u, H, I* ★**

AI1 maximum value.

AI1 voltage scaling parameter of 100%.

This parameter can be accessed if **[AI1 Type] *R, IE*** is set to **[Voltage] *ID, u***.

Setting	Description
0.0...10.0 Vdc	Setting range <b>Factory setting:</b> 10.0 Vdc

**[AI1 min. value] *C, L, I* ★**

AI1 minimum value.

AI1 current scaling parameter of 0%.

This parameter can be accessed if **[AI1 Type] *R, IE*** is set to **[Current] *DR***.

Setting	Description
0.0...20.0 mA	Setting range <b>Factory setting:</b> 0.0 mA

**[AI1 max. value] *C, H, I* ★**

AI1 maximum value.

AI1 current scaling parameter of 100%.

This parameter can be accessed if **[AI1 Type] *R, IE*** is set to **[Current] *DR***.

Setting	Description
0.0...20.0 mA	Setting range <b>Factory setting:</b> 20.0 mA

**[AI1 filter] *R, IF***

AI1 filter.

Interference filtering.

Setting	Description
0.00...10.00 s	Setting range <b>Factory setting:</b> 0.00 s



## [AI2] *R , 2 C* - Menu

### Access

[Display] → [I/O map] → [Analog inputs image] → [AI2]

### [AI2] *R , 2 C*

Physical value AI2.

AI2 customer image: value of analog input 2.

Identical to [AI1] *R , 1 C* (see page 119).

### [AI2 Assignment] *R , 2 R*

Configuration of AI2.

Identical to [AI1 Assignment] *R , 1 R* (see page 119).

### [AI2 min value] *U , L 2* ★

AI2 minimum value.

AI2 voltage scaling parameter of 0%.

This parameter can be accessed if [AI2 Type] *R , 2 E* is set to [Voltage] *1 0 U*.

Identical to [AI1 min value] *U , L 1* (see page 120).

### [AI2 max value] *U , H 2* ★

AI2 maximum value.

AI2 voltage scaling parameter of 100%.

This parameter can be accessed if [AI2 Type] *R , 2 E* is set to [Voltage] *1 0 U*.

Identical to [AI1 max value] *U , H 1* (see page 120).

### [AI2 min. value] *C r L 2* ★

AI2 minimum value.

AI2 current scaling parameter of 0%.

This parameter can be accessed if [AI2 Type] *R , 2 E* is set to [Current] *0 A*.

Identical to [AI1 min. value] *C r L 1* (see page 120).

### [AI2 max. value] *C r H 2* ★

AI2 maximum value.

AI2 current scaling parameter of 100%.

This parameter can be accessed if [AI2 Type] *R , 2 E* is set to [Current] *0 A*.

Identical to [AI1 max. value] *C r H 1* (see page 120).

### [AI2 filter] *R , 2 F*

AI2 filter.

Interference filtering.

Identical to [AI1 filter] *R , 1 F* (see page 120).

## [AI3] *R* , *3* *C* - Menu

### Access

[Display] → [I/O map] → [Analog inputs image] → [AI3]

### [AI3] *R* , *3* *C*

Physical value AI3.

AI3 customer image: value of analog input 3.

Identical to [AI1] *R* , *1* *C* (see page 119).

### [AI3 Assignment] *R* , *3* *R*

Configuration of AI3.

Identical to [AI1 Assignment] *R* , *1* *R* (see page 119).

### [AI3 min value] *u* , *L* *3* ★

AI3 voltage scaling parameter of 0%.

This parameter can be accessed if [AI3 Type] *R* , *3* *E* is set to [Voltage] *I* *0* *u*.

Identical to [AI1 min value] *u* , *L* *1* (see page 120).

### [AI3 max value] *u* , *H* *3* ★

AI3 voltage scaling parameter of 100%.

This parameter can be accessed if [AI3 Type] *R* , *3* *E* is set to [Voltage] *I* *0* *u*.

Identical to [AI1 max value] *u* , *H* *1* (see page 120).

### [AI3 min. value] *C* *r* *L* *3* ★

Value for low speed AI3.

AI3 current scaling parameter of 0%.

This parameter can be accessed if [AI3 Type] *R* , *3* *E* is set to [Current] *0* *R*.

Identical to [AI1 min. value] *C* *r* *L* *1* (see page 120).

### [AI3 max. value] *C* *r* *H* *3* ★

Value for high-speed AI3.

AI3 current scaling parameter of 100%.

This parameter can be accessed if [AI3 Type] *R* , *3* *E* is set to [Current] *0* *R*.

Identical to [AI1 max. value] *C* *r* *H* *1* (see page 120).

### [AI3 Filter] *R* , *3* *F*

AI3 filter.

Interference filtering.

Identical to [AI1 filter] *R* , *1* *F* (see page 120).

## [AI4] R , 4 C - Menu

### Access

[Display] → [I/O map] → [Analog inputs image] → [AI4]

### [AI4] R , 4 C

Physical value AI4.

AI4 customer image: value of analog input 4.

Identical to [AI1] R , 1 C (see page 119).

### [AI4 Assignment] R , 4 R

AI4 functions assignment. If no functions have been assigned, [No] n o is displayed.

Identical to [AI1 Assignment] R , 1 R (see page 119).

### [AI4 min value] u , L 4 ★

AI4 minimum value.

AI4 voltage scaling parameter of 0%.

This parameter can be accessed if [AI4 Type] R , 4 E is set to [Voltage] I D u .

Identical to [AI1 min value] u , L 1 (see page 120).

### [AI4 max value] u , H 4 ★

AI4 maximum value.

AI3 voltage scaling parameter of 100%.

This parameter can be accessed if [AI4 Type] R , 4 E is set to [Voltage] I D u .

Identical to [AI1 max value] u , H 1 (see page 120).

### [AI4 min. value] C r L 4 ★

AI4 minimum value.

AI4 current scaling parameter of 0%.

This parameter can be accessed if [AI4 Type] R , 4 E is set to [Current] D R .

Identical to [AI1 min. value] C r L 1 (see page 120).

### [AI4 max. value] C r H 4 ★

AI4 maximum value.

AI4 current scaling parameter of 100%.

This parameter can be accessed if [AI4 Type] R , 4 E is set to [Current] D R .

Identical to [AI1 max. value] C r H 1 (see page 120).

### [AI4 filter] R , 4 F

Interference filtering cut-off time of the low-filter.

Identical to [AI1 filter] R , 1 F (see page 120).

**[AI5] R , 5 C - Menu****Access**

[Display] → [I/O map] → [Analog inputs image] → [AI5]

**[AI5] R , 5 C**

AI5 customer image: value of analog input 5.  
Identical to **[AI1] R , 1 C** (see page 119).

**[AI5 Assignment] R , 5 A**

AI5 functions assignment. If no functions have been assigned, **[No] n o** is displayed.  
Identical to **[AI1 Assignment] R , 1 A** (see page 119).

**[AI5 min value] v , L 5 ★**

AI5 voltage scaling parameter of 0%.  
This parameter can be accessed if **[AI5 Type] R , 5 E** is set to **[Voltage] I D v**.  
Identical to **[AI1 min value] v , L 1** (see page 120).

**[AI5 max value] v , H 5 ★**

AI3 voltage scaling parameter of 100%.  
This parameter can be accessed if **[AI5 Type] R , 5 E** is set to **[Voltage] I D v**.  
Identical to **[AI1 max value] v , H 1** (see page 120).

**[AI5 min. value] C r L 5 ★**

AI5 current scaling parameter of 0%.  
This parameter can be accessed if **[AI5 Type] R , 5 E** is set to **[Current] D R**.  
Identical to **[AI1 min. value] C r L 1** (see page 120).

**[AI5 max. value] C r H 5 ★**

AI5 current scaling parameter of 100%.  
This parameter can be accessed if **[AI5 Type] R , 5 E** is set to **[Current] D R**.  
Identical to **[AI1 max. value] C r H 1** (see page 120).

**[AI5 filter] R , 5 F**

Interference filtering cut-off time of the low filter.  
Identical to **[AI1 filter] R , 1 F** (see page 120).

---

## [Digital output map] L ◻ R - Menu

### Access

[Display] → [I/O map] → [Digital output map]

### About This Menu

DO assignment.

On the Graphic Display Terminal, click the digital output to see the assignment.

Read-only parameters, cannot be configured.

It displays the function which is assigned to a digital output. If no function has been assigned, **[Not assigned]** ◻ ◻ is displayed.

It allows to verify the delay, active state, and holding time set for the digital output. Possible values are identical as those in the configuration menu.

## [AQ1] *R* *o* *I* *C* - Menu

### Access

[Display] → [I/O map] → [Analog outputs image] → [AQ1]

### Minimum and Maximum Output Values

The minimum output value, in volts, corresponds to the lower limit of the assigned parameter and the maximum value corresponds to its upper limit. The minimum value may be greater than the maximum value.

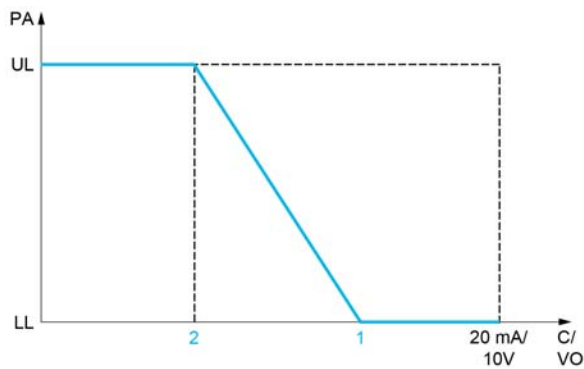
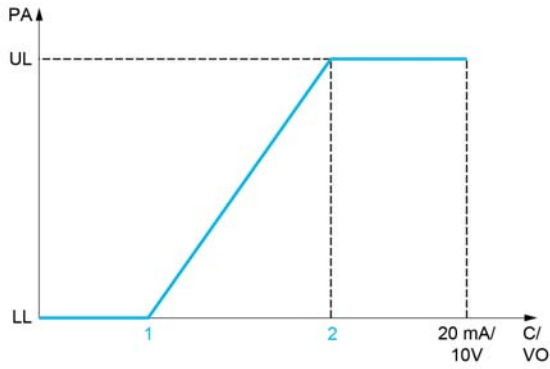

- PA Parameter assigned
- C / VO Current or voltage output
- UL Upper limit
- LL Low limit
- 1 [Min Output] *R* *o* *L* *X* or *u* *o* *L* *X*
- 2 [Max Output] *R* *o* *H* *X* or *u* *o* *H* *X*

### Scaling of the Assigned Parameter

The scale of the assigned parameter can be adapted in accordance with requirements by modifying the values of the lower and upper limits with two parameters for each analogic output.

These parameters are given in %. 100% corresponds to the total variation range of the configured parameter, so: 100% = upper limit - lower limit.

For example, **[Sign. torque] 5 L 9** which varies between -3 and +3 times the rated torque, 100% corresponds to 6 times the rated torque.

- The **[Scaling AQx min] # 5 L X** parameter modifies the lower limit: new value = lower limit + (range x # 5 L X). The value 0% (factory setting) does not modify the lower limit.
- The **[Scaling AQx max] # 5 H X** parameter modifies the upper limit: new value = lower limit + (range x # 5 L X). The value 100% (factory setting) does not modify the upper limit.
- **[Scaling AQx min] # 5 L X** must always be lower than **[Scaling AQx max] # 5 H X**.

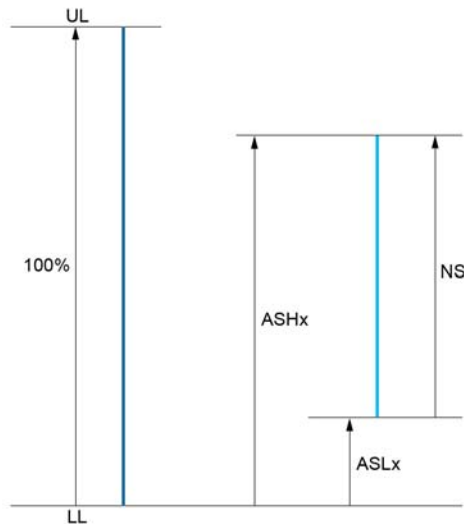

- UL** Upper limit of the assigned parameter
- LL** Lower limit of the assigned parameter
- NS** New scale
- 1 # 5 H X
- 2 # 5 L X

### Application Example

The value of the motor current at the AO1 output is to be transferred with 0...20 mA, range 2 in motor, in motor being the equivalent of a 0.8 In drive.

- The **[Motor Current] # C r** parameter varies from 0 to 2 times the rated drive current.
- **[Scaling AQ1 min] # 5 L 1** must not modify the lower limit, which therefore remains at its factory setting of 0%.
- **[Scaling AQ1 max] # 5 H 1** must modify the upper limit by 0.5x the rated motor torque, or 100 - 100/5 = 80% (new value = lower limit + (range x ASH1)).

### [AQ1] # # 1 C

AO1 customer image: value of analogic output 1.

Setting ( )	Description
-32,767...32,767	Setting range Factory setting: _

**[AQ1 assignment]  $R_{01}$**

AO1 assignment.

Setting	Code / Value	Description
[Not Configured]	$n_0$	Not assigned <b>Factory Setting</b>
[Motor Current]	$o_{Cr}$	Current in the motor, from 0 to 2 In (In = rated drive current indicated in the Installation manual and on the drive nameplate)
[Motor Frequency]	$o_{Fr}$	Output frequency, from 0 to <b>[Max Frequency] <math>f_{Fr}</math></b>
[Ramp out.]	$o_{rP}$	From 0 to <b>[Max Frequency] <math>f_{Fr}</math></b>
[Motor torq.]	$t_{r9}$	Motor torque, from 0 to 3 times the rated motor torque
[Sign. torque]	$5t_9$	Signed motor torque, between -3 and +3 times the rated motor torque. The + sign corresponds to the motor mode and the - sign to the generator mode (braking).
[sign ramp]	$o_{r5}$	Signed ramp output, between - <b>[Max Frequency] <math>f_{Fr}</math></b> and + <b>[Max Frequency] <math>f_{Fr}</math></b>
[PID ref.]	$o_{P5}$	PID controller reference between <b>[Min PID reference] <math>P_{1P1}</math></b> and <b>[Max PID reference] <math>P_{1P2}</math></b>
[PID feedbk]	$o_{PF}$	PID controller feedback between <b>[Min PID feedback] <math>P_{1F1}</math></b> and <b>[Max PID feedback] <math>P_{1F2}</math></b>
[PID error]	$o_{PE}$	PID controller detected error between -5% and +5% of <b>[Max PID feedback] <math>P_{1F2}</math></b> - <b>[Min PID feedback] <math>P_{1F1}</math></b>
[PID output]	$o_{P1}$	PID controller output between <b>[Low speed] <math>L_{5P}</math></b> and <b>[High speed] <math>H_{5P}</math></b>
[Drive power]	$o_{Pr}$	Motor power, between 0 and 2.5 times <b>[Nominal Motor Power] <math>n_{Pr}</math></b>
[Mot thermal]	$t_{Hr}$	Motor thermal state, from 0 to 200% of the rated thermal state
[Drv thermal]	$t_{Hd}$	Drive thermal state, from 0 to 200% of the rated thermal state
[Sig. o/p frq.]	$o_{F5}$	Signed output frequency, between - <b>[Max Frequency] <math>f_{Fr}</math></b> and + <b>[Max Frequency] <math>f_{Fr}</math></b>
[Motor volt.]	$u_{oP}$	Voltage applied to the motor, between 0 and <b>[Nom Motor Voltage] <math>u_{n5}</math></b> warning
[Inlet Pressure Value]	$P_{51u}$	Inlet pressure value
[Outlet Pressure Value]	$P_{52u}$	Outlet pressure value
[Installation Flow]	$F_{51u}$	Installation flow value

**[AQ1 Min Output]  $u_{oL}$  / ★**

AO1 minimum output.

This parameter can be accessed if **[AQ1 Type]  $R_{01E}$**  is set to **[Voltage]  $10u$** .

Setting	Description
0.0...10.0 Vdc	Setting range <b>Factory setting:</b> 0.0 Vdc

**[AQ1 max Output]  $u_{oH}$  / ★**

AO1 maximum output.

This parameter can be accessed if **[AQ1 Type]  $R_{01E}$**  is set to **[Voltage]  $10u$** .

Setting	Description
0.0...10.0 Vdc	Setting range <b>Factory setting:</b> 10.0 Vdc



**[AQ1 min output] *R o L I* ★**

AO1 minimum output.

This parameter can be accessed if **[AQ1 Type] *R o I E*** is set to **[Current] *D R***.

Setting	Description
0.0...20.0 mA	Setting range <b>Factory setting:</b> 0.0 mA

**[AQ1 max output] *R o H I* ★**

AO1 maximum output.

This parameter can be accessed if **[AQ1 Type] *R o I E*** is set to **[Current] *D R***.

Setting	Description
0.0...20.0 mA	Setting range <b>Factory setting:</b> 20.0 mA

**[Scaling AQ2 min] *R 5 L I***

Scaling of the lower limit of the assigned parameter, as a % of the maximum possible variation.

Setting	Description
0.0...100.0%	Setting range <b>Factory setting:</b> 0.0%

**[Scaling AQ1 max] *R 5 H I***

Scaling of the upper limit of the assigned parameter, as a % of the maximum possible variation.

Setting	Description
0.0...100.0%	Setting range <b>Factory setting:</b> 100.0%

**[AQ1 Filter] *R o I F***

Interference filtering.

This parameter is forced to 0 if **[AQ1 assignment] *R o I*** is set to **[DQ1] *d o I***.

Setting	Description
0.00...10.00 s	Setting range <b>Factory setting:</b> 0.00 s

**[AQ2] AO2C - Menu****Access**

**[Display] → [I/O Map] → [Analog outputs image] → [AQ2]**

**[AQ2] AO2C**

AO2 customer image: value of analog output 2.

Identical to **[AQ1] AO1C** (see page 127).

**[AQ2 Assignment] AO2**

AO2 assignment.

Identical to **[AQ1 assignment] AO1** (see page 128).

**[AQ2 Min Output] AOL2★**

AO2 minimum output.

This parameter can be accessed if **[AQ2 Type] AO2E** is set to **[Voltage] IDU**.

Identical to **[AQ1 min Output] AOL1** (see page 128).

**[AQ2 Max Output] AOHE★**

AO2 maximum output.

This parameter can be accessed if **[AQ2 Type] AO2E** is set to **[Voltage] IDU**.

Identical to **[AQ1 max Output] AOH1** (see page 128).

**[AQ2 Min Output] AOL2★**

AO2 minimum output.

This parameter can be accessed if **[AQ2 Type] AO2E** is set to **[Current] DR**.

Identical to **[AQ1 min Output] AOL1** (see page 129).

**[AQ2 Max Output] AOHE★**

AO2 maximum output.

This parameter can be accessed if **[AQ2 Type] AO2E** is set to **[Current] DR**.

Identical to **[AQ1 max Output] AOH1** (see page 129).

**[Scaling AQ2 min] A5L2**

Scaling of the lower limit of the assigned parameter, as a % of the maximum possible variation.

Identical to **[Scaling AQ2 min] A5L1** (see page 129).

**[Scaling AQ2 max] A5H2**

Scaling of the upper limit of the assigned parameter, as a % of the maximum possible variation.

Identical to **[Scaling AQ1 max] A5H1** (see page 129).

**[AQ2 Filter] AO2F**

Interference filtering.

This parameter is forced to 0 if **[AQ2 Assignment] AO2** is set to **[DQ2] DO2**.

Identical to **[AQ1 Filter] AO1F** (see page 129).

## [DI5 frequency measured] P F C 5 - Menu

### Access

[Display] → [I/O map] → [Freq. signal image] → [DI5 frequency measured]

### About This Menu

Following parameters can be accessed on the Graphic Display Terminal by pressing the OK key on the [DI5 Frequency Measured] P F C 5 parameter.

### [DI5 Frequency Measured] P F C 5

Filtered customer pulse input frequency reference.

Setting	Description
0...4,294,967,295	Setting range Factory setting: _

### [DI5 Pulse Input Assign] P , 5 A

Di5 pulse input assignment.

It displays all the functions associated with the pulse input in order to verify, for example, for compatibility problems.

If no functions have been assigned, [No] n o is displayed.

Setting	Code / Value	Description
[No]	n o	Not assigned <b>Factory Setting</b>
[AQ1 assignment]	A o 1	Analog output AQ1
[AQ2 assignment]	A o 2	Analog output AQ2
[Ref Freq Channel 1]	F r 1	Reference frequency channel 1
[Ref Freq Channel 2]	F r 2	Reference frequency channel 2
[Ref Frequency 2 Summing]	S A 2	Reference frequency 2 summing
[PID Feedback]	P , F	PI controller feedback
[Subtract Ref Freq 2]	d A 2	Subtract reference frequency 2
[Manual PID Ref.]	P , n	Manual speed reference of the PID controller (auto-man)
[PID Ref Frequency]	F P ,	PID reference frequency
[Ref Frequency 3 Summing]	S A 3	Reference frequency 3 summing
[Ref Frequency 1B]	F r 1 b	Reference frequency 1B
[Subtract Ref Freq 2]	d A 3	Subtract reference frequency 3
[Forced local]	F L o C	Forced local reference source1
[Ref Frequency 2 multiplier]	n A 2	Reference frequency 2 multiplier
[Ref Frequency 3 multiplier]	n A 3	Reference frequency 3 multiplier
[Virtual AI1 Channel]	A , C 1	Virtual AI1 channel selector function
[InletPres Assign]	P 5 1 A	Select the source of inlet pressure sensor
[OutletPres Assign]	P 5 2 A	Select the source of outlet pressure sensor
[Inst Flow Assign]	F 5 1 A	Select the source of installation flow sensor
[Pump Flow Assign]	F 5 2 A	Select the source of pump flow sensor

### [DI5 PulseInput Low Freq] P , L 5

Di5 pulse input low frequency.

Pulse input scaling parameter of 0% in Hz x 10 unit.

Setting	Description
0.00...30000.00 Hz	Setting range Factory setting: 0 Hz

**[DI5 PulseInput High Freq] P , H 5**

Di5 pulse input high frequency.

Pulse input scaling parameter of 100% in Hz x 10 unit.

Setting	Description
0.00...30.00 kHz	Setting range <b>Factory setting:</b> 30.00 kHz

**[DI5 Frequency Filter] P F , 5**

Interference filtering pulse input cut-off time of the low-filter.

Setting	Description
0...1,000 ms	Setting range <b>Factory setting:</b> 0 ms

## [DI6 frequency measured] P F L 6 - Menu

### Access

[Display] → [I/O map] → [Freq. signal image] → [DI6 frequency measured]

### About This Menu

Following parameters can be accessed on the Graphic Display Terminal by pressing the OK key on the [DI6 Frequency Measured] P F L 6 parameter.

#### [DI6 Frequency Measured] P F L 6

Filtered customer pulse input frequency reference.

Identical to [DI5 frequency measured] P F L 5 (see page 131).

#### [DI6 Pulse Input Assign] P , 6 R

Di6 pulse input assignment.

Identical to [DI5 Pulse Input Assign] P , 5 R (see page 131).

#### [DI6 PulseInput Low Freq] P , L 6

Di6 pulse input low frequency.

Identical to [DI5 PulseInput Low Freq] P , L 5 (see page 131).

#### [DI6 PulseInput High Freq] P , H 6

Di6 pulse input high frequency.

Identical to [DI5 PulseInput High Freq] P , H 5 (see page 132).

#### [DI6 Frequency Filter] P F , 6

Interference filtering pulse input cut-off time of the low-filter.

Identical to [DI5 Frequency Filter] P F , 5 (see page 132).

## Section 6.11

### [Communication map]

#### What Is in This Section?

This section contains the following topics:

Topic	Page
[Communication map] <i>С П П</i> - Menu	135
[Modbus network diag] <i>П н д</i> - Menu	138
[Com. scanner input map] <i>С Ш</i> - Menu	139
[Com scan output map] <i>С Ш</i> - Menu	140
[Modbus HMI Diag] <i>П д H</i> - Menu	141
[Ethernet Emb Diag] <i>П П E</i> - Menu	142
[Ethernet Module Diag] <i>П E E</i> - Menu	143
[DeviceNet Diag] <i>д у н</i> - Menu	144
[Profibus Diag] <i>Р р б</i> - Menu	145
[PROFINET Diag] <i>Р р н</i> - Menu	147
[Command word image] <i>С W</i> - Menu	149
[Freq. ref. word map] <i>р W</i> - Menu	150
[CANopen map] <i>С н П</i> - Menu	151
[PDO1 image] <i>Р д 1</i> - Menu	152
[PDO2 image] <i>Р д 2</i> - Menu	154
[PDO3 image] <i>Р д 3</i> - Menu	155
[CANopen map] <i>С н П</i> - Menu	156

## [Communication map] $\llcorner \llcorner \llcorner$ - Menu

### Access

[Display] → [Communication map]

### [Command Channel] $\llcorner \llcorner \llcorner \llcorner$

Command channel.

Setting	Code / Value	Description
[Terminals]	$\llcorner \llcorner \llcorner$	Terminal block source <b>Factory Setting</b>
[Ref. Freq- Rmt. Term]	$\llcorner \llcorner \llcorner$	Reference Frequency via remote terminal
[Ref. Freq-Modbus]	$\llcorner \llcorner \llcorner$	Reference frequency via Modbus
[Ref. Freq-CANopen]	$\llcorner \llcorner \llcorner$	Reference frequency via CANopen if a CANopen module has been inserted
[Ref. Freq-Com. Module]	$\llcorner \llcorner \llcorner$	Reference frequency via fieldbus module if a fieldbus module has been inserted
[Embedded Ethernet]	$\llcorner \llcorner \llcorner$	Embedded Ethernet

### [Cmd Register] $\llcorner \llcorner \llcorner$

Command register.

[Control Mode]  $\llcorner \llcorner \llcorner \llcorner$  is not set to [I/O profile]  $\llcorner \llcorner$

Possible values in CiA402 profile, separate, or not separate mode:

Bit	Description, Value
0	Set to 1: "Switch on"/Contactor command
1	Set to 0: "Disable voltage"/Authorization to supply AC power
2	Set to 0: "Quick stop"
3	Set to 1: "Enable operation"/Run command
4 to 6	Reserved (= 0)
7	"Fault reset" acknowledgment active on 0 to 1 rising edge
8	Set to 1: Halt stop according to the [Type Of Stop] $\llcorner \llcorner \llcorner$ parameter without leaving the operation enabled state
9 and 10	Reserved (= 0)
11 to 15	Can be assigned to commands

Possible values in the I/O profile. On state command [2-Wire Control]  $\llcorner \llcorner$ :

Bit	Description, Value
0	Forward (on state) command: 0: No forward command 1: Forward command <b>NOTE:</b> The assignment of bit 0 cannot be modified. It corresponds to the assignment of the terminals. It can be switched. Bit 0 $\llcorner \llcorner \llcorner \llcorner$ is only active if the channel of this control word is active.
1 to 15	Can be assigned to commands

Possible values in the I/O profile. On edge command **[3-Wire Control] 3 C**:

Bit	Description, Value
0	Stop (run authorization): 0: Stop 1: Run is authorized on a forward or reverse command
1	Forward (on 0 to 1 rising edge) command
2 to 15	Can be assigned to commands
<b>NOTE:</b> The assignment of bits 0 and 1 cannot be modified. It corresponds to the assignment of the terminals. It can be switched. Bits 0 <b>C d O O</b> and 1 <b>C d O I</b> are only active if the channel of this control word is active.	

**[Ref Freq Channel] r F C C**

Channel of reference frequency.

Identical to **[Command Channel] C n d C** (see page 135)

**[Pre-Ramp Ref Freq] F r H**

Frequency reference before ramp.

Setting	Description
-500.0...500.0 Hz	Setting range <b>Factory setting:</b> _

**[CIA402 State Reg] E L H**

CIA402 State Register.

Possible values in CiA402 profile, separate, or not separate mode:

Bit	Description, Value
0	"Ready to switch on", awaiting power section line supply
1	"Switched on", ready
2	"Operation enabled", running
3	Operating detected error state: 0: Inactive 1: Active
4	"Voltage enabled", power section line supply present: 0: Power section line supply absent 1: Power section line supply present <b>NOTE:</b> When the drive is powered by the power section only, this bit is always at 1.
5	Quick stop
6	"Switched on disabled", power section line supply locked
7	Warning: 0: No warning 1: Warning
8	Reserved (= 0)
9	Remote: command or reference via the network 0: Command or reference via the Graphic Display Terminal 1: Command or reference via the network
10	Targets reference reached: 0: The reference is not reached 1: The reference has been reached <b>NOTE:</b> When the drive is in speed mode, this is the speed reference.
11	"Internal limit active", reference outside limits: 0: The reference is within the limits 1: The reference is not within the limits <b>NOTE:</b> When the drive is in speed mode, the limits are defined by the <b>[Low speed] L 5 P</b> and <b>[High speed] H 5 P</b> parameters.
12	Reserved
<b>NOTE:</b> The combination of bits 0, 1, 2, 4, 5 and 6 defines the state in the DSP 402 state chart (see the communication manuals).	



Bit	Description, Value
13	Reserved
14	"Stop key", STOP via stop key: 0: STOP key not pressed 1: Stop triggered by the STOP key on the Graphic Display Terminal
15	"Direction", direction of rotation: 0: Forward rotation at output 1: Reverse rotation at output
<b>NOTE:</b> The combination of bits 0, 1, 2, 4, 5 and 6 defines the state in the DSP 402 state chart (see the communication manuals).	

Possible values in the I/O profile:

Bit	Description, Value
0	Reserved (= 0 or 1)
1	Ready: 0: Not ready 1: Ready
2	Running: 0: The drive does not start if a reference other than zero is applied 1: Running, if a reference other than zero is applied, the drive can start
3	Operating detected error state: 0: Inactive 1: Active
4	Power section line supply present: 0: Power section line supply absent 1: Power section line supply present
5	Reserved (= 1)
6	Reserved (= 0 or 1)
7	Warning 0: No warning 1: Warning
8	Reserved (= 0)
9	Command via a network: 0: Command via the terminals or the Graphic Display Terminal 1: Command via a network
10	Reference reached: 0: The reference is not reached 1: The reference has been reached
11	Reference outside limits: 0: The reference is within the limits 1: The reference is not within the limits <b>NOTE:</b> When the drive is in speed mode, the limits are defined by LSP and HSP parameters.
12	Reserved (= 0)
13	Reserved (= 0)
14	Stop via STOP key: 0: STOP key not pressed 1: Stop triggered by the STOP key on the Graphic Display Terminal
15	Direction of rotation: 0: Forward rotation at output 1: Reverse rotation at output
<b>NOTE:</b> The value is identical in the CiA402 profile and the I/O profile. In the I/O profile, the description of the values is simplified and does not refer to the CiA402 (Drivecom) state chart.	

**[Modbus network diag] П n d - Menu****Access**

[Display] → [Communication map] → [Modbus network diag]

**About This Menu**

Used for the Modbus serial communication port at the bottom of the control block. Refer to the Modbus serial embedded communication manual for a complete description.

**[COM LED] П d b l**

View of the Modbus communication LED.

**[Mdb Frame Nb] П l c t**

Modbus network frames counter: number of processed frames.

Setting	Description
0...65,535	Setting range <b>Factory setting:</b> _

**[Mb NET CRC errors] П l e c**

Modbus network CRC error counter: number of CRC errors

Setting	Description
0...65,535	Setting range <b>Factory setting:</b> _

## [Com. scanner input map] , 5 # - Menu

### Access

[Display] → [Communication map] → [Modbus network diag] → [Com. scanner input map]

### About This Menu

Used for CANopen® and Modbus network.

### [Com Scan In1 val.] *н П 1*

Com scanner input 1 value. Value of the first input word.

Setting	Description
0...65,535	Setting range Factory setting: _

### [Com Scan In2 val.] *н П 2*

Com scanner input 2 value. Value of the second input word.

Identical to **[Com Scan In1 val.] *н П 1*** (*see page 139*).

### [Com Scan In3 val.] *н П 3*

Com scanner input 3 value. Value of the third input word.

Identical to **[Com Scan In1 val.] *н П 1*** (*see page 139*).

### [Com Scan In4 val.] *н П 4*

Com scanner input 4 value. Value of the fourth input word.

Identical to **[Com Scan In1 val.] *н П 1*** (*see page 139*).

### [Com Scan In5 val.] *н П 5*

Com scanner input 5 value. Value of the fifth input word.

Identical to **[Com Scan In1 val.] *н П 1*** (*see page 139*).

### [Com Scan In6 val.] *н П 6*

Com scanner input 6 value. Value of the sixth input word.

Identical to **[Com Scan In1 val.] *н П 1*** (*see page 139*).

### [Com Scan In7 val.] *н П 7*

Com scanner input 7 value. Value of the seventh input word.

Identical to **[Com Scan In1 val.] *н П 1*** (*see page 139*).

### [Com Scan In8 val.] *н П 8*

Com scanner input 8 value. Value of the eighth input word.

Identical to **[Com Scan In1 val.] *н П 1*** (*see page 139*).

## [Com scan output map] ▢ 5 H - Menu

### Access

[Display] → [Communication map] → [Com scan output map]

### About This Menu

Used for CANopen® and Modbus networks.

### [Com Scan Out1 val.] n L 1

Com scanner output 1 value. Value of the first output word.

Setting 	Description
0...65,535	Setting range Factory setting: _

### [Com Scan Out2 val.] n L 2

Com scanner output 2 value. Value of the second output word.

Identical to [Com Scan Out1 val.] n L 1 (see page 140).

### [Com Scan Out3 val.] n L 3

Com scanner output 3 value. Value of the third output word.

Identical to [Com Scan Out1 val.] n L 1 (see page 140).

### [Com Scan Out4 val.] n L 4

Com scanner output 4 value. Value of the fourth output word.

Identical to [Com Scan Out1 val.] n L 1 (see page 140).

### [Com Scan Out5 val.] n L 5

Com scanner output 5 value. Value of the fifth output word.

Identical to [Com Scan Out1 val.] n L 1 (see page 140).

### [Com Scan Out6 val.] n L 6

Com scanner output 6 value. Value of the sixth output word.

Identical to [Com Scan Out1 val.] n L 1 (see page 140).

### [Com Scan Out7 val.] n L 7

Com scanner output 7 value. Value of the seventh output word.

Identical to [Com Scan Out1 val.] n L 1 (see page 140).

### [Com Scan Out8 val.] n L 8

Com scanner output 8 value. Value of the eighth output word.

Identical to [Com Scan Out1 val.] n L 1 (see page 140).

## [Modbus HMI Diag] П d H - Menu

### Access

[Display] → [Communication map] → [Modbus HMI Diag]

### About This Menu

Used for the Modbus serial communication port at the front of the control block (used by the Graphic Display Terminal)

### [COM LED] П d b 2

View of the Modbus HMI communication LED.

### [Mdb NET frames] П 2 C 4

Terminal Modbus 2: number of processed frames.

Setting ( )	Description
0...65,535	Setting range

### [Mdb NET CRC errors] П 2 E 4

Terminal Modbus 2: number of CRC errors.

Setting ( )	Description
0...65,535	Setting range

## [Ethernet Emb Diag] *Π P E* - Menu

### Access

[Display] → [Communication map] → [Ethernet Emb Diag]

### About This Menu

Refer to the Modbus TCP Ethernet-IP communication module manual.

### [MAC @] *Π P C E*

MAC address of the embedded Ethernet Modbus TCP board.

Read-only parameter.

The address format is XX-XX-XX-XX-XX-XX.

### [ETH emb Rx frames] *E r X E*

Ethernet embedded Rx frames counter.

Setting ( )	Description
0...4,294,967,295	Setting range Factory setting: _

### [ETH emb Tx frames] *E t X E*

Ethernet embedded Tx frames counter.

Setting ( )	Description
0...4,294,967,295	Setting range Factory setting: _

### [ETH emb error frames] *E E r E*

Ethernet embedded error frames counter.

Setting ( )	Description
0...4,294,967,295	Setting range Factory setting: _

### [Ethernet Rate Data] *R r d E* ★

Actual data rate.

Setting ( )	Code / Value	Description
[Auto]	<i>R u t o</i>	Automatic
[10M. full]	<i>1 0 F</i>	10 F
[10M. half]	<i>1 0 H</i>	10 H
[100M. full]	<i>1 0 0 F</i>	100 F
[100M. half]	<i>1 0 0 H</i>	100 H

## [Ethernet Module Diag] *Π Ε Ε* - Menu

### Access

[Display] → [Communication map] → [Ethernet Module Diag]

### About This Menu

Following parameters are accessible if Ethernet-IP - Modbus TCP Module (VW3A3720) has been inserted.

### [MAC @] *Π Α Ε* □

MAC address of the embedded Ethernet Modbus TCP board.

Read-only parameter.

The address format is XX-XX-XX-XX-XX-XX.

### [ETH opt Rx frames] *Ε ρ Χ* □

Ethernet embedded Rx frames counter.

Setting ( )	Description
0...4,294,967,295	Setting range Factory setting: _

### [ETH opt Tx frames] *Ε ε Χ* □

Ethernet embedded Tx frames counter.

Setting ( )	Description
0...4,294,967,295	Setting range Factory setting: _

### [ETH opt error frames] *Ε Ε ρ* □

Ethernet embedded error frames counter.

Setting ( )	Description
0...4,294,967,295	Setting range Factory setting: _

### [Actual rate] *Α ρ Δ* ★

Actual data rate.

Setting ( )	Code / Value	Description
[Auto]	<i>Α ο ε</i>	Automatic
[10M. full]	<i>10 F</i>	10 F
[10M. half]	<i>10 H</i>	10 H
[100M. full]	<i>100 F</i>	100 F
[100M. half]	<i>100 H</i>	100 H

## [DeviceNet Diag] *d u n* - Menu

### Access

[Display] → [Communication map] → [DeviceNet Diag]

### About This Menu

Following parameters can be accessible if DeviceNet module (VW3A3609) has been inserted.

### [Data rate used] *b d r u* ★

Data rate used by the fieldbus module.

Setting	Code / Value	Description
[Automatic]	<i>R u t o</i>	Automatic detection <b>Factory setting</b>
[125 Kbps]	<i>1 2 5 K</i>	125,000 Bauds
[250 Kbps]	<i>2 5 0 K</i>	250,000 Bauds
[500 Kbps]	<i>5 0 0 K</i>	500,000 Bauds

### [Fieldbus Error] *E P F 2*

External detected error from fieldbus module.

### [Fieldbus Com Interrupt] *C n F*

Fieldbus module communication interruption. Refer to the related fieldbus manual.

Setting	Description
0...65,535	Setting range <b>Factory setting:</b> _



## [Profibus Diag] *P r b* - Menu

### Access

[Display] → [Communication] → [Profibus Diag]

### About This Menu

Following parameters are accessible if Profibus DP module (VW3A3607) has been inserted.

### [Data rate used] *b d r u* ★

Data rate used by the fieldbus module.

Setting( )	Code / Value	Description
[Automatic]	<i>A u t o</i>	Automatic detection <b>Factory setting</b>
[9.6 Kbps]	<i>9 K 6</i>	9,600 Bauds
[19.2 Kbps]	<i>1 9 K 2</i>	19,200 Bauds
[93.75 Kbps]	<i>9 3 K 7</i>	93,750 Bauds
[187.5 Kbps]	<i>1 8 7 K</i>	187,500 Bauds
[500 Kbps]	<i>5 0 0 K</i>	500,000 Bauds
[1.5 Mbps]	<i>1 5 0</i>	1.5 MBauds
[3 Mbps]	<i>3 0</i>	3 MBauds
[6 Mbps]	<i>6 0</i>	6 MBauds
[12 Mbps]	<i>1 2 0</i>	12 MBauds

### [PPO profile used] *P r F L* ★

PPO profile in use.

Setting( )	Code / Value	Description
[Not configured]	<i>u n C G</i>	Not configured
[1]	<i>1</i>	PROFIdrive
[100]	<i>1 0 0</i>	Device specific
[101]	<i>1 0 1</i>	Device specific
[102]	<i>1 0 2</i>	Device specific

### [DP Master Active] *d P M A* ★

Active master: 1 or 2.

Setting( )	Code / Value	Description
[MCL1]	<i>1</i>	Master 1 <b>Factory setting</b>
[MCL2]	<i>2</i>	Master 2

### [Fieldbus Error] *E P F 2*

External detected error from fieldbus module.

**[Fieldbus Com Interrupt] L n F**

Fieldbus module communication interruption. Refer to the related fieldbus manual.

Setting()	Description
0...65,535	Setting range <b>Factory setting:</b> _

**[InternCom Error1] , L F I**

Option module communication interruption. Refer to the related fieldbus manual.

Setting()	Description
0...65,535	Setting range <b>Factory setting:</b> _

## [PROFINET Diag] *P r n* - Menu

### Access

[Display] → [Communication map] → [PROFINET Diag]

### About This Menu

Following parameters are accessible if PROFINET® module (VW3A3627) has been inserted.

### [MAC @] *n A C*

MAC address of the embedded Ethernet Modbus TCP board.

read-only parameter.

The address format is XX-XX-XX-XX-XX-XX.

### [PPO profile used] *P r F L* ★

PPO profile in use.

Setting( )	Code / Value	Description
[Not configured]	<i>u n C C</i>	Not configured
[1]	<i>1</i>	PROFIdrive
[100]	<i>1 0 0</i>	Device specific
[101]	<i>1 0 1</i>	Device specific
[102]	<i>1 0 2</i>	Device specific
[106]	<i>1 0 6</i>	Device specific
[107]	<i>1 0 7</i>	Device specific

### [Ethernet Error Code] *E r r* ★

Ethernet specific error code.

Setting( )	Description
0...65,535	Setting range <b>Factory setting:</b> 0

### [iPar Status] *i P A E* ★

PROFINET: IPAR service status.

Setting( )	Code / Value	Description
[Idle State]	<i>i d L E</i>	Idle state
[Init]	<i>i n i t</i>	Initialization
[Configuration]	<i>C o n F</i>	Configuration
[Ready]	<i>r d Y</i>	Ready
[Operational]	<i>o P E</i>	Operational
[Not Configured]	<i>u C F C</i>	Not configured
[Unrecoverable Error]	<i>u r E C</i>	Unrecoverable detected error

### [iPar Error Code] *i P A d* ★

IPar detected error code.

Setting( )	Description
0...5	Setting range <b>Factory setting:</b> 0

**[DP Master Active]** *DPMA*★

Active master: 1 or 2.

Setting( )	Code / Value	Description
[MCL1]	1	Master 1 <b>Factory setting</b>
[MCL2]	2	Master 2

**[Fieldbus Error]** *EPF2*

External detected error from fieldbus module.

**[Fieldbus Com Interrupt]** *CONF*

Fieldbus module communication interruption.

Setting( )	Description
0...65,535	Setting range <b>Factory setting:</b> _

**[InternCom Error1]** *ILFI*

Option module communication interruption.

Setting( )	Description
0...65,535	Setting range <b>Factory setting:</b> _

---

## [Command word image] *Cmd* - Menu

### Access

[Display] → [Communication map] → [Command word image]

### About This Menu

Command word image.

### [Modbus Cmd] *Cmd 1*

Command word image built with Modbus port source.

Identical to [CMD Value] *Cmd* (*see page 135*).

### [CANopen Cmd] *Cmd 2*

Command word image built with CANopen® port source.

Identical to [CMD Value] *Cmd* (*see page 135*).

### [COM. Module Cmd.] *Cmd 3*

Command word image built with fieldbus module source.

Identical to [CMD Value] *Cmd* (*see page 135*).

### [Ethernet Embd cmd.] *Cmd 5*

Command word image built with Ethernet embedded source).

Identical to [CMD Value] *Cmd* (*see page 135*).

## [Freq. ref. word map] *r W 1* - Menu

### Access

[Display] → [Communication map] → [Freq. ref. word map]

### About This Menu

Frequency reference image.

### [Modbus Ref Freq] *L F r 1*

Frequency reference image built with Modbus port source (LFR\_MDB).

Setting 	Description
-32,768...32,767 Hz	Setting range <b>Factory setting:</b> 0.0 Hz

### [CAN Ref Freq] *L F r 2*

Frequency reference image built with CANopen® port source (LFR\_CAN).

Setting 	Description
-32,768...32,767 Hz	Setting range <b>Factory setting:</b> 0.0 Hz

### [Com Module Ref Freq] *L F r 3*

Frequency reference image built with fieldbus module source (LFR\_COM).

Setting 	Description
-32,768...32,767 Hz	Setting range <b>Factory setting:</b> 0.0 Hz

### [Ethernet Embd Ref Freq] *L F r 5*

Embedded Ethernet reference frequency.

Setting 	Description
-32,768...32,767 Hz	Setting range <b>Factory setting:</b> 0.0 Hz

---

## [CANopen map] *C n Π* - Menu

### Access

[Display] → [Communication map] → [CANopen map]

### About This Menu

This menu is visible if a CANopen fieldbus module is present. Refer to the CANopen communication module manual.

### [RUN LED] *C o n*

Bitfield: view of the CANopen® Run LED status.

### [ERR LED] *C n E*

Bitfield: view of the CANopen® error LED status.

**[PDO1 image] P D I - Menu****Access**

[Display] → [Communication map] → [CANopen map] → [PDO1 image]

**About This Menu**

View of the Receive PDO1 and Transmit PDO1.

**[Receive PDO1-1] r P I 1★**

First frame of the receive PDO1.

Setting	Description
0...65,535	Setting range <b>Factory setting:</b> _

**[Receive PDO1-2] r P I 2★**

Second frame of the receive PDO1.

Setting	Description
0...65,535	Setting range <b>Factory setting:</b> _

**[Receive PDO1-3] r P I 3★**

Third frame of the receive PDO1.

Setting	Description
0...65,535	Setting range <b>Factory setting:</b> _

**[Receive PDO1-4] r P I 4★**

Fourth frame of the receive PDO1.

Setting	Description
0...65,535	Setting range <b>Factory setting:</b> _

**[Transmit PDO1-1] t P I 1★**

First frame of the transmit PDO1.

Setting	Description
0...65,535	Setting range <b>Factory setting:</b> _

**[Transmit PDO1-2] t P I 2★**

Second frame of the transmit PDO1.

Setting	Description
0...65,535	Setting range <b>Factory setting:</b> _



**[Transmit PDO1-3]** *EP 13* ★

Third frame of the transmit PDO1.

Setting	Description
0...65,535	Setting range <b>Factory setting:</b> _

**[Transmit PDO1-4]** *EP 14* ★

Fourth frame of the transmit PDO1.

Setting	Description
0...65,535	Setting range <b>Factory setting:</b> _

## [PDO2 image] P 0 2 - Menu

### Access

[Display] → [Communication map] → [CANopen map] → [PDO2 image]

### About This Menu

View of the RPDO2 and TPDO2: same structure as [PDO1 image] P 0 1 - ([see page 152](#)).

#### [Receive PDO2-1] r P 2 1 ★

First frame of the receive PDO2.

#### [Receive PDO2-2] r P 2 2 ★

Second frame of the receive PDO2.

#### [Receive PDO2-3] r P 2 3 ★

Third frame of the receive PDO2.

#### [Receive PDO2-4] r P 2 4 ★

Fourth frame of the receive PDO2.

#### [Transmit PDO2-1] t P 2 1 ★

First frame of the transmit PDO2.

#### [Transmit PDO2-2] t P 2 2 ★

Second frame of the transmit PDO2.

#### [Transmit PDO2-3] t P 2 3 ★

Third frame of the transmit PDO2.

#### [Transmit PDO2-4] t P 2 4 ★

Fourth frame of the transmit PDO2.

## [PDO3 image] P 0 3 - Menu

### Access

[Display] → [Communication map] → [CANopen map] → [PDO3 image]

### About This Menu

View of the RPDO3 and TPDO3.

### [Receive PDO3-1] r P 3 1 ★

First frame of the receive PDO3.

Setting ( )	Description
0...65,535	Setting range Factory setting: _

### [Receive PDO3-2] r P 3 2 ★

Second frame of the receive PDO3.

Identical settings as in [Receive PDO3-1] r P 3 1.

### [Receive PDO3-3] r P 3 3 ★

Third frame of the receive PDO3.

Identical settings as in [Receive PDO3-1] r P 3 1.

### [Receive PDO3-4] r P 3 4 ★

Fourth frame of the receive PDO3.

Identical settings as in [Receive PDO3-1] r P 3 1.

### [Transmit PDO3-1] t P 3 1 ★

First frame of the transmit PDO3.

Setting ( )	Description
0...65,535	Setting range Factory setting: _

### [Transmit PDO3-2] t P 3 2 ★

Second frame of the transmit PDO3.

Identical settings as in [Transmit PDO3-1] t P 3 1.

### [Transmit PDO3-3] t P 3 3 ★

Third frame of the transmit PDO3.

Identical settings as in [Transmit PDO3-1] t P 3 1.

### [Transmit PDO3-4] t P 3 4 ★

Fourth frame of the transmit PDO3.

Identical settings as in [Transmit PDO3-1] t P 3 1.

## [CANopen map] *C n Π - Menu*

### Access

[Display] → [Communication map] → [CANopen map]

### About This Menu

CANopen® image.

### [Canopen NMT state] *n Π k 5*

Drive NMT state of the CANopen® slave.

Settings	Code / Value	Description
[Boot]	<i>b o o k</i>	Bootup
[Stopped]	<i>S t o P</i>	Stopped
[Operation]	<i>o P E</i>	Operational
[Pre-op]	<i>P o P E</i>	Pre-Operational

### [Number of TX PDO] *n b k P*

Number of transmit PDO.

Setting ( )	Description
0...65,535	Setting range Factory setting: _

### [Number of RX PDO] *n b r P*

Number of receive PDO.

Setting ( )	Description
0...65,535	Setting range Factory setting: _

### [CANopen Error] *E r C o*

Error registry CANopen®.

Setting	Description
0...5	Setting range Factory setting: _

### [RX Error Counter] *r E C ,*

Number of receive error counter (not saved at power off).

Setting	Description
0...65,535	Setting range Factory setting: _

### [TX Error Counter] *t E C ,*

Number of transmit errors countered (not saved at power off).

Setting	Description
0...65,535	Setting range Factory setting: _

---

## Section 6.12

### [Data logging]

---

#### What Is in This Section?

This section contains the following topics:

Topic	Page
[Distributed logging] <i>d L o</i> - Menu	158
[Log dstrb prm select] <i>L d P</i> - Menu	159
[Distributed logging] <i>d L o</i> - Menu	160

## [Distributed logging] *d L o* - Menu

### Access

[Display] → [Data logging] → [Distributed logging]

### About This Menu

This menu is used to store data following specific parameters.

The distributed logging function allows to log up to four parameter distributions at the same time. Each parameter storage is synchronized with the same sample time.

The result of this function gives the possibility to extract a bar graph with 10 bars (every 10% of the defined maximum value) to visualize the distribution for each of the four selected parameters.

**NOTE:** Any modification of the data logging function configuration will clear the data previously stored.

This function aims at extracting samples of data to store them. When available, these samples can be uploaded by other tools (SoMove and/or Webserver). Data logging meets the need to record and store data over time.

The drive can store the following data:

Type of [Data logging]	Description	[Data logging] storage: Automatic/Manual	Access
Drive identification	Drive identification data	Automatic, in [Dashboard] <i>d S H</i> - menu	SoMove Webserver
Even warning logging	Warning logging	Automatic, in [Dashboard] <i>d S H</i> - menu	SoMove Webserver
Even error logging	Error logging	Automatic, in [Dashboard] <i>d S H</i> - menu	SoMove Webserver
Distribution logging	4 Distribution data	Manual	Webserver
Energy logging	1 Energy logging data	Automatic, in [Dashboard] <i>d S H</i> - menu	SoMove Webserver

### Activation

To activate [Distributed logging] *d L o* - :

- Select 1 to 4 data to store with [Log dstrb prm select] *L d P* -
- Set [Log Distrib State] *L d E n* to [Start] *S t A r t*

The logging starts as soon as the motor is running.

To stop logging, set [Log Distrib State] *L d E n* to [Stop] *S t o P*.

### [Log Distrib State] *L d E n*

Logging distribution state.

Setting ( )	Code / Value	Description
[Stop]	<i>S t o P</i>	Distribution logging disabled <b>Factory setting</b>
[Start]	<i>S t A r t</i>	Distribution logs only when the motor is started
[Always]	<i>A L W A Y S</i>	Distribution logs all the time
[Reset]	<i>r E S E t</i>	Distribution logging reset (configuration, data)
[Clear]	<i>C L E A r</i>	Clear distribution data
[Error]	<i>E r r o r</i>	An error has been detected during distribution logging

## [Log dstrb prm select] *L d P* - Menu

### Access

[Display] → [Data logging] → [Distributed logging] → [Log dstrb prm select]

### About This Menu

This menu allows you to select up to 4 parameters for data logging. The peak value for each parameter is also stored.

### [Log Distrib. Data 1] *L d d 1*

Logging distribution data 1.

Setting ( )	Code / Value	Description
[Distrib. Log. Disable]	<i>n o</i>	Distribution logging disable <b>Factory setting</b>
[Motor Frequency]	<i>r F r</i>	Motor frequency
[Motor Current]	<i>L C r</i>	Motor current
[Motor Speed]	<i>S P d</i>	Motor speed
[Motor Voltage]	<i>u o P</i>	Motor voltage
[Motor Mech. Power]	<i>o P r W</i>	Motor mechanical power
[Input Elec. Power]	<i>i P r W</i>	Input electrical power
[Output Elec. Power]	<i>E P r W</i>	Output electrical power
[Motor Torque]	<i>o t r</i>	Motor torque
[Mains Voltage]	<i>u L n</i>	Mains voltage
[DC BUS Voltage]	<i>u b u S</i>	DC BUS voltage
[PID Feedback]	<i>r P F</i>	PID feedback
[AI2 Th Value]	<i>t H 2 u</i>	Thermal sensor AI2
[AI3 Th Value]	<i>t H 3 u</i>	Thermal sensor AI3
[AI4 Th Value]	<i>t H 4 u</i>	Thermal sensor AI4
[AI5 Th Value]	<i>t H 5 u</i>	Thermal sensor AI5
[Drive Thermal State]	<i>t H d</i>	Drive thermal state
[Motor Therm State]	<i>t H r</i>	Motor thermal state
[Installation Flow]	<i>F S 1 u</i>	Installation flow
[Pump Flow]	<i>F S 2 u</i>	Pump flow
[Inlet Pressure Value]	<i>P S 1 u</i>	Inlet pressure sensor
[Outlet Pressure Value]	<i>P S 2 u</i>	Outlet pressure sensor
[Energy Consum. Ind.]	<i>E C i</i>	Energy consumption indicator
[Pump Efficiency]	<i>E F Y</i>	Pump efficiency
[Energy Perf. Ind.]	<i>E P i</i>	Energy performance indicator

### [Log Distrib. Data 2] *L d d 2*

Logging distribution data 2.

Identical to [Log Distrib. Data 1] *L d d 1* (see page 159).

### [Log Distrib. Data 3] *L d d 3*

Logging distribution data 3.

Identical to [Log Distrib. Data 1] *L d d 1* (see page 159).

### [Log Distrib. Data 4] *L d d 4*

Logging distribution data 4.

Identical to [Log Distrib. Data 1] *L d d 1* (see page 159).

## [Distributed logging] *L d L o* - Menu

### Access

[Display] → [Data logging] → [Distributed logging]

### About This Menu

**NOTE:** If a log data exceeds the user defined maximum values for log distribution data, this value will not be stored in the log distribution.

### [Log Distrib Slp Time] *L d S t*

Logging distribution sample time.

Setting ( )	Code / Value	Description
[200 ms]	<i>2 0 0 0 5</i>	200 ms
[1 second]	<i>1 5</i>	1 s Factory setting
[2 second]	<i>2 5</i>	2 s
[5 second]	<i>5 5</i>	5 s

### [Dist Max Val 1] *L d 1*

Maximum value of the log distribution data 1.

Setting ( )	Description
10...65,535	Setting range Factory setting: _

### [Dist Max Val 2] *L d 2*

Maximum value of the log distribution data 2.

Setting ( )	Description
10...65,535	Setting range Factory setting: _

### [Dist Max Val 3] *L d 3*

Maximum value of the log distribution data 3.

Setting ( )	Description
10...65,535	Setting range Factory setting: _

### [Dist Max Val 4] *L d 4*

Maximum value of the log distribution data 4.

Setting ( )	Description
10...65,535	Setting range Factory setting: _



# Chapter 7

## [Complete settings] $\llcorner$ 5 $\llcorner$ -

### Introduction



**[Complete settings]  $\llcorner$  5  $\llcorner$  -** menu presents all the settings related to drive functions for:

- Motor and drive configuration
- Application functions
- Monitoring functions

### What Is in This Chapter?

This chapter contains the following sections:

Section	Topic	Page
7.1	Overview	163
7.2	[Macro configuration]	166
7.3	[Motor parameters]	167
7.4	[Define system units]	199
7.5	[Sensors assignment]	203
7.6	[Command and Reference]	251
7.7	[Pump functions] - [Booster control]	263
7.8	[Pump functions] - [Level control]	281
7.9	[Pump functions] - [PID controller]	304
7.10	[Pump functions] - [Sleep/wakeup]	323
7.11	[Pump functions] - [Feedback monitoring]	365
7.12	[Pump functions] - [Pump characteristics]	367
7.13	[Pump functions] - [Sensorless flow estimation]	375
7.14	[Pump functions] - [Pump start stop]	378
7.15	[Pump functions] - [Pipe fill]	382
7.16	[Pump functions] - [Friction loss compensation]	396
7.17	[Pump functions] - [Jockey pump]	409
7.18	[Pump functions] - [Priming pump ctrl]	411
7.19	[Pump functions] - [Flow limitation]	423
7.20	[Pump monitoring] - [Pumpcycle monitoring]	437
7.21	[Pump monitoring] - [Anti jam]	439
7.22	[Pump monitoring] - [Dry run]	445
7.23	[Pump monitoring] - [Pump low flow Monit]	448
7.24	[Pump monitoring] - [Pump thermal monit]	465
7.25	[Pump monitoring] - [Inlet pressure monitori..]	473
7.26	[Pump monitoring] - [Outlet pressure monitoring]	486
7.27	[Pump monitoring] - [High flow monitoring]	498
7.28	[Fan] - [PID controller]	511
7.29	[Fan] - [Feedback monitoring]	530
7.30	[Fan] - [Jump frequency]	531
7.31	[Fan]	532
7.32	[Generic functions] - [Speed limits]	534
7.33	[Generic functions] - [Ramp]	537
7.34	[Generic functions] - [Ramp switching]	540
7.35	[Generic functions] - [Stop configuration]	542
7.36	[Generic functions] - [Auto DC injection]	548

Section	Topic	Page
7.37	[Generic functions] - [Ref. operations]	551
7.38	[Generic functions] - [Preset speeds]	553
7.39	[Generic functions] - [+/- speed]	557
7.40	[Generic functions] - [Jump frequency]	560
7.41	[Generic functions] - [PID controller]	561
7.42	[Generic functions] - [Feedback mon.]	580
7.43	[Generic functions] - [Threshold reached]	581
7.44	[Generic functions] - [Mains contactor command]	583
7.45	[Generic functions] - [Reverse disable]	585
7.46	[Generic functions] - [Torque limitation]	586
7.47	[Generic functions] - [Parameters switching]	588
7.48	[Generic functions] - [Stop on prolonged spd]	597
7.49	[Generic monitoring]	599
7.50	[Input/Output] - [I/O assignment]	606
7.51	[Input/Output] - [DI/DQ]	628
7.52	[Input/Output] - [Analog I/O]	648
7.53	[Input/Output] - [Relay]	665
7.54	[Error/Warning handling]	673
7.55	[Maintenance]	698

## Section 7.1

### Overview

#### Application Control Mode

##### Introduction

There are five application control modes for the pump controller.

The application control mode is determined according to the selected channel and **[PID regul.] P, d** mode.

This table presents the priority order of the control modes:

Priority	Channel	Function	Control mode
1	Local	<i>FLC</i> or <i>ELK</i>	Local
2	Channel 2	<i>Fr2</i>	Override
3	Channel 1	<i>P, n</i>	PID manu
4	Channel 1	<i>P, SP</i>	PID auto
5	Channel 1	<i>Fr1</i> or <i>Fr1b</i>	Speed control

##### Application Control Functions

Application control functions are not all available in all modes. This table presents the availability of each function according to the selected mode:

Function	Channel 1			Channel 2	Local	Application status
	<i>P, n</i> Manu	<i>P, SP</i> Auto	No <i>P, d</i>			
Reference Frequency Source	<i>P, n</i>	<i>P, SP</i>	<i>Fr1</i> or <i>Fr1b</i>	<i>Fr2</i>	<i>b n P</i> or <i>FLC</i>	–
Centrifugal Pump Start & Stop	Yes	Yes	Yes	Yes	Yes	–
Thermal Pump Monitoring	Yes	Yes	Yes	Yes	Yes	–
Anti-Jam	Yes	Yes	Yes	No	No	<i>A J A n</i>
Priming Pump Control	Yes	Yes	Yes	No	No	<i>P r, n</i>
Pipe Fill	Yes	Yes	Yes	No	No	<i>F, L L</i>
Dry Run Pump Monitoring	Yes	Yes	Yes	No	No	–
Pump Low Flow Monitoring	Yes	Yes	Yes	No	No	–
Pumpcycle Monitoring	Yes	Yes	Yes	No	No	–
High Flow Monitoring	Yes	Yes	Yes	No	No	–
Flow Limitation	Yes	Yes	Yes	No	No	<i>FL, n</i>
Outlet Pressure Monitoring	Yes	Yes	Yes	No	No	–
Inlet Pressure Monitoring	Yes	Yes	Yes	No	No	<i>C o n P</i>
Process Control (PID)	Yes (Manu)	Yes (Auto)	Not configured	No	No	<i>A u t o n n u</i>
PID Controller	Yes	Yes	No	No	No	<i>b o o s t S L E E P</i>
Sleep Wake-Up (Pressure Control)	No	Yes	No	No	No	–
Advanced sleep Checking (Pressure Control)	No	Yes	No	No	No	–
Friction Loss Compensation	No	Yes	No	No	No	–
<b>1</b> Multi-pump Management is active for Booster or Level Control. When Booster and Level Control are both inactive, all auxiliary pumps are stopped.						

Function	Channel 1			Channel 2	Local	Application status
	Pid Manu	Pid Auto	No Pid			
Jockey Pump Control	No	Yes	No	No	No	-
PID Feedback Monitoring	No	Yes	No	No	No	-
Stop After Speed Timeout	Yes	No	Yes	Yes	Yes	<b>S L E E P</b>
Multi-pump Management	Yes <sup>(1)</sup>	Yes <sup>(1)</sup>	Yes <sup>(1)</sup>	-	-	-
Booster Control	Yes	Yes	Yes	No	No	-
Level Control	N/A	N/A	Yes	No	No	-

**1** Multi-pump Management is active for Booster or Level Control. When Booster and Level Control are both inactive, all auxiliary pumps are stopped.

**Reference Channel Overview with PID Configured**

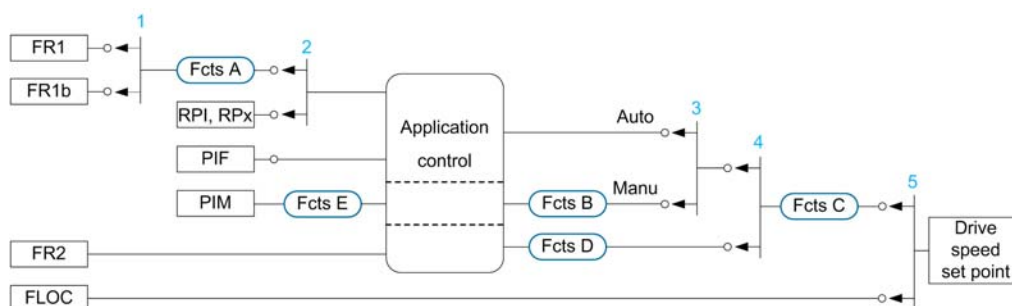

- 1 Commutation between channel 1 and channel 1b done with **[Acceleration 2] r C b** parameter
- 2 Choice of the process setpoint done with **[Intern PID Ref] P i i** parameter
- 3 Manual function of the **[PID regul.] P i d**, commutation done with **[Auto/Manual assign.] P R u** parameter
- 4 Choice between channel 1 and channel 2 done with **[Freq Switch Assign] r F C** parameter
- 5 Forced local mode activated by the function **[Forced Local Assign] F L a** or **[T/K] F n E K**

## Reference Channel Overview with PID Not Configured

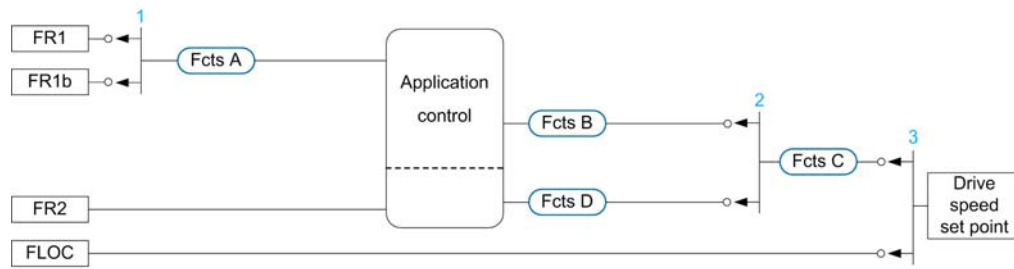

- 1 Commutation between channel 1 and channel 1b done with **[Acceleration 2]** *r C b* parameter
- 2 Choice between channel 1 and channel 2 done with **[Freq Switch Assign]** *r F C* parameter
- 3 Forced local mode activated by the function **[Forced Local Assign]** *F L a* or **[T/K]** *F n E K*

## Monitoring Functions

This table presents the function availability depending on the application status:

Application status	System monitoring functions			Pump monitoring functions (pump running)			
	Outlet low pressure	Outlet high pressure	High flow	Inlet low pressure	Pump low flow	Dry run	Pumpcycle
<i>A J A n</i>	No	No	No	No	No	No	Only 1 per cycle
<i>P r , n</i>	No	Yes	Yes	N/A or no	N/A	N/A	N/A
<i>F , L L</i>	No	Yes	Yes	Yes	Yes	Yes	Each start
<i>r u n , n A n u , A u t o , F L , n , C o n P</i>	Yes	Yes	Yes	Yes	Yes	Yes	Each start
<i>b o o s t</i>	Yes	Yes	Yes	Yes	Yes	Yes	N/A
<i>S L E E P</i>	Yes	Yes	Yes	N/A or no	N/A	N/A	N/A
<i>J o c k e y</i>	Yes	Yes	Yes	Yes (1)	Yes (1)	Yes (1)	Each start (1)

1 If the VSD pump is used as a jockey pump

## Section 7.2

### [Macro configuration]

#### [Macro configuration] *Π Ε ρ* - Menu

##### Access

[Complete settings] → [Macro configuration]

##### About This Menu

This menu allows to select an application type in order to display only the parameters and menus useful for the selected application.

The application type selection should be done prior to the application settings.

##### [Application Selection] *Α Ρ Ρ Ε*

Application selection.

### **WARNING**

#### **UNANTICIPATED EQUIPMENT OPERATION**

If this parameter is changed, the functions that are active with the current configuration are disabled and the assignments of the inputs used in these functions are reset to the factory setting.

Verify that this change is compatible with the type of wiring used.

**Failure to follow these instructions can result in death, serious injury, or equipment damage.**

Setting	Code / Value	Description
[Generic Pump Control]	<i>Γ Ρ Π Ρ</i>	Generic pump control application <b>Factory setting</b>
[Pump Level Control]	<i>Λ Ε V E L</i>	Pump level control application
[Pump Booster Control]	<i>β ο ο 5 ε</i>	Pump booster control application
[Generic Fan Control]	<i>Φ Α η</i>	Generic fan control application

## Section 7.3

### [Motor parameters]

#### What Is in This Section?

This section contains the following topics:

Topic	Page
[Motor parameters] <i>PPA</i> - Menu	168
[Data] <i>PEd</i> - Menu	170
[Motor tune] <i>PEu</i> - Menu	177
[Motor monitoring] <i>POP</i> - Menu	181
[Pump thermal monit] <i>EPF</i> - Menu	182
[Motor monitoring] <i>POP</i> - Menu	190
[Motor control] <i>drc</i> - Menu	192
[Switching frequency] <i>SWF</i> - Menu	197

## [Motor parameters] *MPA* - Menu

### Access

[Complete settings] → [Motor parameters]

### About This Menu

For an application where less than 110% of overload is required

- Power rating of the drive could be equal to power rating of the motor
- Normal rating should be used

For an application where more that 110% of overload is required (up to 150%)

- Power rating of the drive should be greater than power rating of the motor
- High rating could be used to pre-adjust motor nameplate parameter

If high rating is selected, drive current limitation is extended to 1.5. In and maximum values of motor parameters linked to current and/or power are reduced. When switching from one to another selection, all the related parameters are set to their factory setting values.

In any case, the maximum current of the drive does not change. Setting the drive in high rating mode decrease the nominal values for the motor parameters. It means that for the same motor name plate, an oversized drive is required in high rating mode.

### [Dual Rating] *drL*

Dual rating state.

Setting	Code / Value	Description
[Normal rating]	<i>nor PRL</i>	Normal rating, drive current limitation is 1.1 In <b>Factory setting</b>
[High rating]	<i>HIGH</i>	High rating, drive current limitation is 1.5 In



**[Motor Control Type] E L L**

Motor control type.

**NOTE:** Select the motor control type before entering parameter values.

Setting	Code / Value	Description
[U/F VC Standard]	S L d	Standard motor control type. For applications that require torque at low speed. This motor control type can be used for motors connected in parallel.
[U/F VC 5pts]	u F 5	<p>5-segment V/F profile: As [U/F VC Standard] S L d profile but also supports the avoidance of resonance (saturation).</p> <p>The profile is defined by the values of parameters <math>u n 5</math>, <math>F r 5</math>, <math>u 1</math> to <math>u 5</math> and <math>F 1</math> to <math>F 5</math>.  <math>F r 5 &gt; F 5 &gt; F 4 &gt; F 3 &gt; F 2 &gt; F 1</math></p> <p><b>NOTE:</b> U0 is the result of an internal calculation based on motor parameters and multiplied by <math>u F r</math> (%). U0 can be adjusted by modifying <math>u F r</math> value.</p>
[U/F VC Quad.]	u F 9	<p>Motor control type dedicated to variable torque applications, typically used for pumps and fans.</p> <p><b>Factory setting</b></p>
[SYN_U VC]	S Y n u	<p>Motor control type specific for permanent magnet synchronous motors.</p> <p><b>[Stall Monitoring] S L P C</b> function helps to prevent a motor overload by monitoring the motor current and the speed rise time.</p>
[U/F VC Energy Sav.]	E L o	<p>Specific motor control type optimized for energy saving.</p> <p>This motor control type automatically reduces the drive output current according to the motor load. This automatic current level adaptation allows energy saving for periods when load is kept to a minimum and preserves the drive performance up to full load.</p>

**[Data] *n l d* - Menu**

**Access**

[Complete settings] → [Motor parameters] → [Motor data] → [Data]

**About This Menu**

For synchronous motor parameters. Dedicated parameters can be accessed if [Motor Control Type] *l l l* is set to [SYN\_U VC] *5 Y n u*.

<b>NOTICE</b>
<p><b>RISK OF DAMAGE TO THE MOTOR AND THE DRIVE</b></p> <ul style="list-style-type: none"> <li>Check that the motor will withstand this current, particularly in the case of permanent magnet synchronous motors, which are susceptible to demagnetization.</li> <li>Check that the profile mission complies with the derating curve given in the installation manual.</li> </ul> <p><b>Failure to follow these instructions can result in equipment damage.</b></p>

This table presents the steps to follow to set and optimize the motor data:

Step	Action
1	Enter the motor nameplate
2	Perform the [Autotuning] <i>l u n</i> operation
3	Adjust [Syn. EMF constant] <i>P H 5</i> to optimize the behavior: <ul style="list-style-type: none"> <li>Start the motor at minimal stable frequency available on the machine (at minimum load).</li> <li>Check and note the [% error EMF sync] <i>r d R E</i> value:                             <ul style="list-style-type: none"> <li>If the [% error EMF sync] <i>r d R E</i> value is lower than 0%, then [Syn. EMF constant] <i>P H 5</i> may be increased.</li> <li>If the [% error EMF sync] <i>r d R E</i> value is upper than 0%, then [Syn. EMF constant] <i>P H 5</i> may be reduced. [% error EMF sync] <i>r d R E</i> value should be closed to 0%.</li> </ul> </li> <li>Stop the motor for modify [Syn. EMF constant] <i>P H 5</i> in accordance with the value of the [% error EMF sync] <i>r d R E</i> (previously noted).</li> </ul>

**[Motor Standard] *b F r* ★**

Motor standard.

This parameter modifies the presets of the following parameters:

- [High Speed] *H 5 P*
- [Motor Freq Thd] *F l d*
- [Nom Motor Voltage] *u n 5*
- [Nominal Motor Freq] *F r 5*
- [Max Frequency] *l F r*

This parameter cannot be accessed if [Motor Control Type] *l l l* is set to [SYN\_U VC] *5 Y n u*.

Setting	Code / Value	Description
[50 Hz IEC]	<i>5 0</i>	IEC Factory setting
[60 Hz NEMA]	<i>6 0</i>	NEMA

**[Nominal Motor Power] *n P r* ★**

Nominal motor power.

This parameter cannot be accessed if [Motor Control Type] *l l l* is set to [SYN\_U VC] *5 Y n u*.

Rated motor power given on the nameplate, in kW if [Motor Standard] *b F r* is set to [50Hz IEC] *5 0*, in HP if [Motor Standard] *b F r* is set to [60Hz NEMA] *6 0*.

Setting	Description
According to drive rating	– Factory setting: according to the drive rating

**[Nom Motor Voltage]  $u_n 5$  ★**

Nominal motor voltage.

This parameter cannot be accessed if **[Motor Control Type]  $C E E$**  is set to **[SYN\_U VC]  $5 Y n u$** .

Rated motor voltage given on the nameplate.

Setting	Description
100...690 Vac	Setting range <b>Factory setting:</b> according to drive rating and <b>[Motor Standard] <math>b F r</math></b>

**[Nom Motor Current]  $n C r$  ★**

Rated motor current given on the nameplate.

This parameter cannot be accessed if **[Motor Control Type]  $C E E$**  is set to **[SYN\_U VC]  $5 Y n u$** .

Setting	Description
0.25...1.5 In <sup>(1)</sup>	Setting range <b>Factory setting:</b> according to drive rating and <b>[Motor Standard] <math>b F r</math></b>
<b>(1)</b> Corresponding to the rated drive current indicated in the installation manual and on the drive nameplate.	

**[Nominal Motor Freq]  $F r 5$  ★**

Nominal motor frequency.

This parameter cannot be accessed if **[Motor Control Type]  $C E E$**  is set to **[SYN\_U VC]  $5 Y n u$** .

The factory setting is 50 Hz, or preset to 60 Hz if **[Motor Standard]  $b F r$**  is set to 60 Hz.

Setting	Description
40.0...500.0 Hz	Setting range <b>Factory setting:</b> 50 Hz

**[Nominal Motor Speed]  $n 5 P$  ★**

Nominal motor speed.

This parameter cannot be accessed if **[Motor Control Type]  $C E E$**  is set to **[SYN\_U VC]  $5 Y n u$** .

If the nameplate indicates the synchronous speed and the slip in Hz or as a %, use any 1 of the formulas to calculate the rated speed:

- Nominal speed = Synchronous speed x  $\frac{100 - \text{slip as a \%}}{100}$
- Nominal speed = Synchronous speed x  $\frac{60 - \text{slip in Hz}}{60}$  (60 Hz motors)
- Nominal speed = Synchronous speed x  $\frac{50 - \text{slip in Hz}}{50}$  (50 Hz motors).

Setting	Description
0...65,535 rpm	Setting range <b>Factory setting:</b> according to drive rating

**[Motor Param Choice]  $n P C$  ★**

Motor parameter choice.

This parameter can be accessed if **[Motor Control Type]  $C E E$**  is not set to **[SYN\_U VC]  $5 Y n u$**  and if **[Motor param choice]  $n P C$**  is set to **[Mot Power]  $n P r$** .

Setting	Code / Value	Description
<b>[Mot Power]</b>	$n P r$	Motor power <b>Factory setting</b>
<b>[Mot Cosinus]</b>	$C o 5$	Motor cosinus

**[Motor 1 Cosinus Phi]  $C_{\phi 5}$  ★**

Nominal motor cosinus Phi.

This parameter can be accessed if **[Motor Control Type]  $C_{\text{t} \text{t} \text{t}}$**  is not set to **[SYN\_U VC]  $S_{YNU}$**  and if **[Motor param choice]  $\Pi P C$**  is set to **[Mot Cosinus]  $C_{\phi 5}$** .

Setting	Description
0.50...1.00	Setting range <b>Factory setting:</b> according to the drive rating

**[AsyncMotor R Stator]  $r_{sR}$  ★**

Asynchronous motor stator resistance.

This parameter can be accessed if **[Access Level]  $L_{RL}$**  is set to **[Expert]  $E_{Pr}$**  and if **[Motor Control Type]  $C_{\text{t} \text{t} \text{t}}$**  is not set to **[SYN\_U VC]  $S_{YNU}$** .

The factory setting is replaced by the result of the autotuning operation if it has been performed.

Setting	Description
0...65,535 mOhm	Setting range <b>Factory setting:</b> 0 mOhm

**[Magnetizing Current]  $i_{dR}$  ★**

Magnetizing current.

This parameter can be accessed if **[Access Level]  $L_{RL}$**  is set to **[Expert]  $E_{Pr}$**  and if **[Motor Control Type]  $C_{\text{t} \text{t} \text{t}}$**  is not set to **[SYN\_U VC]  $S_{YNU}$** .

Setting	Description
0...6,553.5 A	Setting range <b>Factory setting:</b> 0 A

**[AsyncMotor L Induct]  $L_{FR}$  ★**

Asynchronous motor leakage inductance.

This parameter can be accessed if **[Access Level]  $L_{RL}$**  is set to **[Expert]  $E_{Pr}$**  and if **[Motor Control Type]  $C_{\text{t} \text{t} \text{t}}$**  is not set to **[SYN\_U VC]  $S_{YNU}$** .

The factory setting is replaced by the result of the autotuning operation if it has been performed.

Setting	Description
0...655.35 mH	Setting range <b>Factory setting:</b> 0 mH

**[Rotor Time Const]  $t_{rR}$  ★**

Rotor time constant.

This parameter can be accessed if **[Access Level]  $L_{RL}$**  is set to **[Expert]  $E_{Pr}$**  and if **[Motor Control Type]  $C_{\text{t} \text{t} \text{t}}$**  is not set to **[SYN\_U VC]  $S_{YNU}$** .

Setting	Description
0...65,535 ms	Setting range <b>Factory setting:</b> 0 ms

**[Sync Nominal I] n C r 5 ★**

Sync motor nominal current.

This parameter can be accessed if **[Motor Control Type] C E E** is set to **[SYN\_U VC] 5 Y n u**.

Setting	Description
0.25...1.5 I <sub>n</sub> <sup>(1)</sup>	Setting range <b>Factory setting:</b> according to the drive rating.
<b>(1)</b> Corresponding to the rated drive current indicated in the installation manual and on the drive nameplate.	

**[Nom SyncMotor Speed] n 5 P 5 ★**

Nominal synchronous motor speed.

This parameter can be accessed if **[Motor Control Type] C E E** is set to **[SYN\_U VC] 5 Y n u**.

Setting	Description
0...48,000 rpm	Setting range <b>Factory setting:</b> according to the drive rating.

**[Nom Motor torque] E 9 5 ★**

Nominal motor torque

This parameter can be accessed if **[Motor Control Type] C E E** is set to **[SYN\_U VC] 5 Y n u**.

Setting	Description
0.1...6,553.5 Nm	Setting range <b>Factory setting:</b> according to the drive rating.

**[Pole pairs] P P n 5 ★**

Pole pairs.

This parameter can be accessed if **[Motor Control Type] C E E** is set to **[SYN\_U VC] 5 Y n u**.

Setting	Description
1...50	Setting range <b>Factory setting:</b> according to the drive rating.

**[Angle setting type] P 5 E ★**

Automatic angle setting type.

This parameter can be accessed if **[Motor Control Type] C E E** is set to **[SYN\_U VC] 5 Y n u**.

This function is used to align the rotor or to compute the angle of the rotor flux linked to permanent magnets in order to reduce torque jolt at start-up.

Setting	Code / Value	Description
<b>[PSI align]</b>	<b>P 5 i</b>	Pulse signal injection. Standard alignment mode, without rotor motion The angle measurement is realized by monitoring the stator current response to a pulse signal injection over a wide range of frequencies
<b>[PSIO align]</b>	<b>P 5 io</b>	Pulse signal injection - optimized. Optimized alignment mode, without rotor motion Same operation as <b>[PSI align] P 5 i</b> is performed over an optimized range of frequencies The measurement time is reduced after the first run order or tune operation, even if the drive has been turned off <b>Factory setting</b>
<b>[Rotational Current Injection]</b>	<b>r C i</b>	Rotational current injection. Alignment mode with rotor motion. This alignment mode realizes the mechanical alignment of the rotor and the stator, it requires up to 4s. The motor needs to be stopped and without resistive torque.
<b>[No align]</b>	<b>n o</b>	No alignment

**[Syn. EMF constant] PHS** ★

Synchronous motor: permanent magnet flux with R/W access to the customer.

This parameter can be accessed if **[Access Level] LRC** is set to **[Expert] EPR** and if **[Motor Control Type] LLL** is set to **[SYN\_UVC] SYN**.

PHS adjustment allows you to reduce the current in operation without load.

Setting	Description
0...6,553.5 mV/rpm	Setting range <b>Factory setting:</b> 0 mV/rpm

**[SyncMotor Stator R] r5R5** ★

Calculated synchronous motor stator R.

Cold state stator resistance (per winding). The factory setting is replaced by the result of the tuning operation if it has been performed.

This parameter can be accessed if **[Access Level] LRC** is set to **[Expert] EPR** and if **[Motor Control Type] LLL** is set to **[SYN\_UVC] SYN**.

You can enter the value if you know it.

Setting ( )	Description
0...65,535 mOhm	Setting range <b>Factory setting:</b> 0 mOhm

**[Autotune L d-axis] Ld5** ★

Autotune L d-axis.

Axis "d" stator inductance in mH (per phase).

This parameter can be accessed if **[Access Level] LRC** is set to **[Expert] EPR** and if **[Motor Control Type] LLL** is set to **[SYN\_UVC] SYN**.

On motors with smooth poles **[Autotune L d-axis] Ld5 = [Autotune L q-axis] Lq5 = Stator inductance L.**

The factory setting is replaced by the result of the autotuning operation if it has been performed.

Setting	Description
0...655.35 mH	Setting range <b>Factory setting:</b> 0

**[Autotune L q-axis] Lq5** ★

Autotune L q-axis.

Axis "q" stator inductance in mH (per phase).

This parameter can be accessed if **[Access Level] LRC** is set to **[Expert] EPR**.

On motors with smooth poles **[Autotune L d-axis] Ld5 = [Autotune L q-axis] Lq5 = Stator inductance L.**

The factory setting is replaced by the result of the autotuning operation if it has been performed.

Setting	Description
0...655.35 mH	Setting range <b>Factory setting:</b> 0

**[Sync Nominal Freq]  $F_r$  5 5 ★**

Synchronous motor nominal frequency.

Nominal motor frequency for synchronous motor in Hz unit. Automatically updated according to **[Nom SyncMotor Speed]  $n$  5 P 5** and **[Pole pairs] P P n 5** data.

This parameter can be accessed if **[Access Level] L R C** is set to **[Expert] E P r**.

Setting ( )	Description
10...500 Hz	Setting range Factory setting: $n$ 5 P 5 * P P n 5 / 60

**[PSI Align Curr Max]  $\Pi$  C r ★**

Maximum current of PSI alignment.

Current level in % of **[Sync Nominal I]  $n$  C r 5** for **[PSI align] P 5 i**, and **[PSI Oalign] P 5 i o** angle shift measurement modes. This parameter has an impact on the inductor measurement.

This parameter can be accessed if **[Access Level] L R C** is set to **[Expert] E P r**.

This current must be equal to or higher than the maximum current level of the application; otherwise an instability may occur.

If **[PSI Align Curr Max]  $\Pi$  C r** is set to **[AUTO] A u t o**, **[PSI Align Curr Max]  $\Pi$  C r** = 150% of **[Sync Nominal I]  $n$  C r 5** during the tune operation and 100% of **[Sync Nominal I]  $n$  C r 5** during angle shift measurement in case of standard alignment **[PSI align] P 5 i** or **[PSI Oalign] P 5 i o**.

Setting	Description
<b>[AUTO] A u t o</b> ...300%	Setting range Factory setting: <b>[AUTO] A u t o</b>

**[Current Filter Time] C r t F ★**

Filter time of the current.

This parameter can be accessed if **[Access Level] L R C** is set to **[Expert] E P r**.

Setting	Description
<b>[AUTO] A u t o</b> ...100.0 ms	Setting range Factory setting: <b>[AUTO] A u t o</b>

**[Currents Filter] C r F R ★**

Internal currents filter time.

This parameter can be accessed if **[Access Level] L R C** is set to **[Expert] E P r**.

Setting ( )	Description
0.0...100.0 ms	Setting range Factory setting: $n$ 5 P 5 * P P n 5 / 60

**[% error EMF sync] *r d R E* ★**

Ratio D-axis current.

This parameter can be accessed if **[Motor Control Type] *C L E*** is set to **[SYN\_UVC] *S Y n u***.

Use **[% error EMF sync] *r d R E*** to adjust **[Syn. EMF constant] *P H 5***, **[% error EMF sync] *r d R E*** should be closed to 0%.

If the **[% error EMF sync] *r d R E*** value is:

- Lower than 0%: **[Syn. EMF constant] *P H 5*** may be increased.
- Upper than 0%: **[Syn. EMF constant] *P H 5*** may be reduced.

For the all steps to follow to optimize the synchronous motor settings ([see page 170](#)).

Setting 	Description
-3,276.7...3,275.8 %	Setting range Factory setting: _



## [Motor tune] $\Pi \text{ } \text{t} \text{ } \text{u}$ - Menu

### Access

[Complete settings] → [Motor parameters] → [Motor data] → [Motor tune]

### [Autotuning] $\text{t} \text{ } \text{u} \text{ } \text{n}$

## DANGER

### HAZARD OF ELECTRIC SHOCK OR ARC FLASH

During [Autotuning]  $\text{t} \text{ } \text{u} \text{ } \text{n}$ , the motor operates at nominal current.

- Verify that the same precautions are in place during [Autotuning]  $\text{t} \text{ } \text{u} \text{ } \text{n}$  as during normal operation of the motor as specified in product manuals and in the manual of the motor.

**Failure to follow these instructions will result in death or serious injury.**

## WARNING

### LOSS OF CONTROL

- The parameters [Nom Motor Voltage]  $\text{u} \text{ } \text{n} \text{ } \text{S}$ , [Nominal Motor Freq]  $\text{F} \text{ } \text{r} \text{ } \text{S}$ , [Nom Motor Current]  $\text{n} \text{ } \text{C} \text{ } \text{r}$ , [Nominal Motor Speed]  $\text{n} \text{ } \text{S} \text{ } \text{P}$ , and [Nominal motor power]  $\text{n} \text{ } \text{P} \text{ } \text{r}$  or [Motor 1 Cosinus Phi]  $\text{C} \text{ } \text{o} \text{ } \text{s}$  must be correctly set before starting autotuning.
- When one or more of these parameters have been changed after autotuning has been performed, [Autotuning]  $\text{t} \text{ } \text{u} \text{ } \text{n}$  will return  $\text{n} \text{ } \text{o}$  and the autotuning will have to be repeated.

**Failure to follow these instructions can result in death, serious injury, or equipment damage.**

In any case, the motor has to be stopped before performing a tune operation. Verify that the application does not make the motor turn during the tune operation.

The tune operation optimizes:

- The motor performances at low speed.
- The estimation of the motor torque.
- The accuracy of the estimation of the process values in sensorless operation and monitoring.

Autotuning is only performed if no stop command has been activated. If a “freewheel stop” or “fast stop” function has been assigned to a digital input, this input must be set to 1 (active at 0).

Autotuning takes priority over any run or prefluxing commands, which will be taken into account after the autotuning sequence.

If autotuning has detected error, the drive always displays [No action]  $\text{n} \text{ } \text{o}$  and, depending on the configuration of [Tuning Error Resp]  $\text{t} \text{ } \text{n} \text{ } \text{L}$ , may switch to [Autotuning]  $\text{t} \text{ } \text{u} \text{ } \text{n}$  detected error mode.

Autotuning may last for several seconds. Do not interrupt the process. Wait for the Graphic Display Terminal to change to [No action]  $\text{n} \text{ } \text{o}$ .

**NOTE:** The motor thermal state has a significant influence on the tuning result. Always perform a motor tuning with the motor stopped and cold. Verify that the application does not have the motor operate during a tuning operation.

To redo a motor tuning, wait that it is stopped and cold. Set first [Autotuning]  $\text{t} \text{ } \text{u} \text{ } \text{n}$  to [Erase Autotuning]  $\text{E} \text{ } \text{r} \text{ } \text{a} \text{ } \text{s} \text{e}$ , then redo the motor tuning.

The use of the motor tuning without doing a [Erase Autotuning]  $\text{E} \text{ } \text{r} \text{ } \text{a} \text{ } \text{s} \text{e}$  first is used to get the thermal state estimation of the motor.

The cable length has an influence on the tune result. If the wiring is modified, it is necessary to redo the tune operation.

Setting ( )	Code / Value	Description
[No action]	<i>n o</i>	Autotuning not in progress <b>Factory setting</b>
[Apply Autotuning]	<i>y e s</i>	Autotuning is performed immediately if possible, then the parameter automatically changes to [No action] <i>n o</i> . If the drive state does not allow the tune operation immediately, the parameter changes to [No] <i>n o</i> and the operation must be done again.
[Erase Autotuning]	<i>c l r</i>	The motor parameters measured by the autotuning function are reset. The default motor parameter values are used to control the motor. [Autotuning Status] <i>t u s</i> is set to [Not done] <i>t r b</i> .

[Autotuning Status] *t u s*

Autotuning status.

(for information only, cannot be modified)

This parameter is not saved at drive power-off. It shows the autotuning status since the last power-on.

Setting ( )	Code / Value	Description
[Not done]	<i>t r b</i>	The autotuning is not done <b>Factory setting</b>
[Pending]	<i>p e n d</i>	The autotuning has been requested but not yet performed
[In Progress]	<i>p r o g</i>	The autotuning is in progress
[Failed]	<i>f r a i l</i>	The autotuning has detected an error
[Done]	<i>d o n e</i>	The motor parameters measured by the autotuning function are used to control the motor

[Tuning Error Resp] *t n l* ★

Response to autotune error.

This parameter can be accessed if [Access Level] *L R C* is set to [Expert] *E P r*.

Setting	Code / Value	Description
[Ignore]	<i>n o</i>	Detected error ignored
[Freewheel Stop]	<i>y e s</i>	Freewheel stop <b>Factory setting</b>

[Autotuning Assign] *t u l* ★

Autotuning input assignment.

The autotuning is performed when the assigned input or bit changes to 1.

This parameter can be accessed if [Access Level] *L R C* is set to [Expert] *E P r*.

**NOTE:** The autotuning causes the motor to start up.

Setting	Code / Value	Description
[Not Assigned]	<i>n o</i>	Not assigned <b>Factory setting</b>
[DI1]...[DI6]	<i>L 1 1 ... L 1 6</i>	Digital input DI1...DI6
[DI11]...[DI16]	<i>L 1 1 1 ... L 1 1 6</i>	Digital input DI11...DI16 if VW3A3203 I/O extension module has been inserted
[CD00]...[CD10]	<i>C d 0 0 ... C d 1 0</i>	Virtual digital input CMD.0...CMD.10 in [I/O profile] <i>i o</i> configuration
[CD11]...[CD15]	<i>C d 1 1 ... C d 1 5</i>	Virtual digital input CMD.11...CMD.15 regardless of configuration
[C100]...[C110]	<i>C 1 0 0 ... C 1 1 0</i>	Virtual digital input CMD1.0...CMD1.10 with integrated Modbus Serial in [I/O profile] <i>i o</i> configuration
[C111]...[C115]	<i>C 1 1 1 ... C 1 1 5</i>	Virtual digital input CMD1.11...CMD1.15 with integrated Modbus Serial regardless of configuration

Setting	Code / Value	Description
[C200]...[C210]	C 2 0 0 ... C 2 1 0	Virtual digital input CMD2.0...CMD2.10 with CANopen® fieldbus module in <b>[I/O profile]</b> configuration
[C211]...[C215]	C 2 1 1 ... C 2 1 5	Virtual digital input CMD2.11...CMD2.15 with CANopen® fieldbus module regardless of configuration
[C300]...[C310]	C 3 0 0 ... C 3 1 0	Virtual digital input CMD3.0...CMD3.10 with a fieldbus module in <b>[I/O profile]</b> configuration
[C311]...[C315]	C 3 1 1 ... C 3 1 5	Virtual digital input CMD3.11...CMD3.15 with a fieldbus module regardless of configuration
[C500]...[C510]	C 5 0 0 ... C 5 1 0	Virtual digital input CMD5.0...CMD5.10 with integrated Ethernet Modbus TCP in <b>[I/O profile]</b> configuration
[C511]...[C515]	C 5 1 1 ... C 5 1 5	Virtual digital input CMD5.11...CMD5.15 with integrated Ethernet Modbus TCP regardless of configuration

### [Automatic autotune] *A u t* ★

Automatic autotune.

## DANGER

### HAZARD OF ELECTRIC SHOCK OR ARC FLASH

If this function is activated, autotuning is performed each time the drive is switched on.

- Verify that activating this function does not result in unsafe conditions.

**Failure to follow these instructions will result in death or serious injury.**

The motor must be stopped when switching on the drive.

This parameter can be accessed if **[Access Level]** *L A C* is set to **[Expert]** *E P r*.

Setting ( )	Code / Value	Description
[No]	n o	Function deactivated <b>Factory setting</b>
[Yes]	y e s	A tuning is automatically done at each power-up

### [Tune Selection] *S e l* ★

Tune selection.

This parameter can be accessed if **[Access Level]** *L A C* is set to **[Expert]** *E P r*.

(for information only, cannot be modified)

Setting ( )	Code / Value	Description
[Default]	t r b	The default motor parameter values are used to control the motor <b>Factory setting</b>
[Measure]	m e a s	The values measured by the autotuning function are used to control the motor
[Custom]	c u s	The values manually set are used to control the motor

**[Angle setting type] P5L ★**

Automatic angle setting type.

This parameter can be accessed if **[Motor Control Type] CLL** is set to **[SYN\_UVC] 5Ynu**.

This function is used to align the rotor or to compute the angle of the rotor flux linked to permanent magnets in order to reduce torque jolt at start-up.

Setting	Code / Value	Description
<b>[PSI align]</b>	P5L	Pulse signal injection. Standard alignment mode, without rotor motion The angle measurement is realized by monitoring the stator current response to a pulse signal injection over a wide range of frequencies
<b>[PSIO align]</b>	P5Lo	Pulse signal injection. Optimized alignment mode, without rotor motion Same operation as <b>[PSI align] P5L</b> , is performed over an optimized range of frequencies The measurement time is reduced after the first run order or tune operation, even if the drive has been turned off <b>Factory setting</b>
<b>[Rotational Current Injection]</b>	rCL	Rotational current injection. Alignment mode with rotor motion. This alignment mode realizes the mechanical alignment of the rotor and the stator, it requires up to 4s. The motor needs to be stopped and without resistive torque.
<b>[No align]</b>	no	No alignment

**[PSI Align Curr Max] PCLr ★**

Maximum current of PSI alignment.

Current level in % of **[Sync Nominal I] nCLrS** for **[PSI align] P5L**, and **[PSI Oalign] P5Lo** angle shift measurement modes. This parameter has an impact on the inductor measurement.

This parameter can be accessed if **[Access Level] LAL** is set to **[Expert] EPr**.

This current must be equal to or higher than the maximum current level of the application, otherwise an instability may occur.

If **[PSI Align Curr Max] PCLr** is set to **[AUTO] Rubo**, **[PSI Align Curr Max] PCLr = 150%** of **[Sync Nominal I] nCLrS** during the tune operation and 100% of **[Sync Nominal I] nCLrS** during angle shift measurement in case of standard alignment **[PSI align] P5L**, or **[PSI O align] P5Lo**.

Setting	Description
<b>[AUTO] Rubo...300%</b>	Setting range <b>Factory setting: [AUTO] Rubo</b>

**[Rotational Current Level] rCLL ★**

Rotational current level.

This parameter can be accessed if **[Angle setting type] P5L** is set to **[Rotational Current Injection] rCL**.

Setting	Description
10...300%	Setting range, as a percentage of the nominal motor current <b>Factory setting: 75%</b>

**[Rotational Torque Curve] rELC ★**

Alignment rotational torque curve.

This parameter can be accessed if

- **[Access Level] LAL** is set to **[Expert] EPr**, and
- **[Angle setting type] P5L** is set to **[Rotational Current Injection] rCL**,

Setting	Description
0... <b>[Rotational Current Level] rCLL</b>	Setting range <b>Factory setting: 0%</b>

**[Motor monitoring]  $\Pi \square P$  - Menu****Access**

[Complete settings] → [Motor parameters] → [Motor monitoring]

**[Motor Th Current]  $i_{tH}$** 

Motor thermal monitoring current to be set to the rated current indicated on the nameplate.

Setting ( )	Description
0.2...1.1_In <sup>(1)</sup>	Setting range <b>Factory setting:</b> According to drive rating
(1) Corresponding to the rated drive current indicated in the installation manual and on the drive nameplate.	

**[Motor Thermal Mode]  $t_{HL}$** 

Motor thermal monitoring mode.

**NOTE:** An error is detected when the thermal state reaches 118% of the rated state and reactivation occurs when the state falls back below 100%.

Setting	Code / Value	Description
[No]	$n \square$	No thermal monitoring
[Self cooled]	$H \square L$	Self ventilated motor <b>Factory setting</b>
[Force-cool]	$F \square L$	Fan-cooled motor

**[MotorTemp ErrorResp]  $\square L L$** 

Overload error response.

Setting	Code / Value	Description
[Ignore]	$n \square$	Detected error ignored
[Freewheel Stop]	$Y E 5$	Free wheel <b>Factory setting</b>

## [Pump thermal monit] $\hookrightarrow$ P P - Menu

### Access

[Complete settings]  $\rightarrow$  [Motor parameters]  $\rightarrow$  [Motor thermal monitoring]  $\rightarrow$  [Pump thermal monit]

### About This Menu

The thermal monitoring function helps to prevent against high temperature by monitoring the real temperature by the drive.

PTC, PT100, PT1000, and KTY84 thermal probes are supported by this function.

The function gives the possibility to manage two levels of monitoring:

- A Warning level: the drive triggers an event without stopping the application.
- An Error level: the drive triggers an event and stops the application.

The thermal probe is monitored for the following detected error:

- Overheating
- Probe break (loss of signal)
- Probe short-circuit

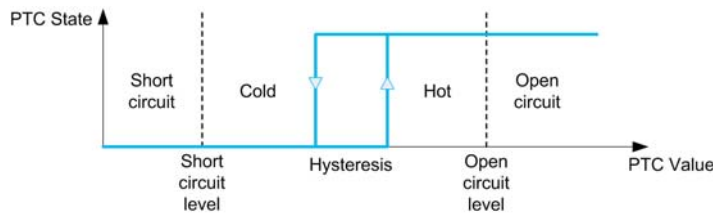

### Activation

[Alx Th Monitoring]  $\hookrightarrow$  H X 5 allows you to activate the thermal monitoring on the related analog input:

- [No] n o: the function is disabled
- [Yes] y e 5: the thermal monitoring is enabled on the related Alx.

### Type of Thermal Probe Selection

[Alx Type] R , X L allows you to select the type of thermal sensors connected on the related analog input:

- [No] n o: no sensor
- [PTC Management] P L c: 1 to 6 PTC (in serial) is used
- [KTY] K L y: 1 KTY84 is used
- [PT100] I P L 2: 1 PT100 connected with 2 wires is used
- [3PT100] 3 P L 2: 3 PT100 connected with 2 wires are used
- [PT1000] I P L 3: 1 PT1000 connected with 2 wires is used
- [3PT1000] 3 P L 3: 3 PT1000 connected with 2 wires are used
- [PT100 in 3 wires] I P L 2 3: 1 PT100 connected with 3 wires is used (AI4 & AI5 only)
- [3PT100 in 3 wires] 3 P L 2 3: 3 PT100 connected with 3 wires are used (AI4 & AI5 only)
- [PT1000 in 3 wires] I P L 3 3: 1 PT1000 connected with 3 wires is used (AI4 & AI5 only)
- [3PT1000 in 3 wires] 3 P L 3 3: 3 PT1000 connected with 3 wires are used (AI4 & AI5 only)

2-wire thermal probes are supported on analog input 2 to analog input 5.

3-wire thermal probes are supported on analog input 4 and analog input 5. These inputs are available with the I/O extension option module.

If the probe is far from the drive, the 3-wire connection is recommended as compared to a 2-wire connection.

**NOTE:** In case of 3 serial probes, the drive monitors the average probe values.

### Wiring for PT100 and PT1000 Probes

For 2-wire probes, the following wirings are possible:

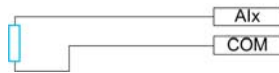

For 3-wire probes, the following wirings are possible:



### [AI2 Th Monitoring] Ɨ H 2 5

Activation of the thermal monitoring on AI2.

Setting	Code / Value	Description
[No]	n o	No <b>Factory setting</b>
[YES]	Ƴ E 5	Yes

### [AI2 Type] R , 2 Ɨ ★

AI2 assignment.

This parameter can be accessed if [AI2 Th Monitoring] Ɨ H 2 5 is not set to [No] n o.

Setting	Code / Value	Description
[Voltage]	1 0 Ƶ	0-10 Vdc <b>Factory setting</b>
[Current]	0 R	0-20 mA
[PTC Management]	P Ɨ Ɨ	1 to 6 PTC (in serial)
[KTY]	K Ɨ Ƴ	1 KTY84
[PT1000]	1 P Ɨ 3	1 PT1000 connected with 2 wires
[PT100]	1 P Ɨ 2	1 PT100 connected with 2 wires
[Water Prob]	L E Ƶ E L	Water level
[3PT1000]	3 P Ɨ 3	3 PT1000 connected with 2 wires
[3PT100]	3 P Ɨ 2	3 PT100 connected with 2 wires

**[AI2 Th Error Resp] 𐄂 H 2 𐄂 ★**

Thermal monitoring response to a detected error for AI2.

This parameter can be accessed if **[AI2 Type] 𐄂 , 2 𐄂** is not set to

- **[Voltage] 1 0 𐄂**, or
- **[Current] 0 𐄂**.

Setting	Code / Value	Description
<b>[Ignore]</b>	<i>n 𐄂</i>	Detected error ignored
<b>[Freewheel Stop]</b>	<i>𐄂 E 5</i>	Freewheel stop
<b>[Per STT]</b>	<i>5 𐄂 𐄂</i>	Stop according to <b>[Type of stop] 5 𐄂 𐄂</b> parameter but without an error triggered after stop
<b>[Fallback Speed]</b>	<i>L F F</i>	Change to fallback speed, maintained as long as the detected error persists and the run command has not been removed <sup>(1)</sup>
<b>[Ramp stop]</b>	<i>r 𐄂 P</i>	Stop on ramp <b>Factory setting</b>

**1** Because, in this case, the detected error does not trigger a stop, it is recommended to assign a relay or logic output to its indication.

**[AI2 Th Error Level] 𐄂 H 2 F ★**

Error detection level for AI2.

This parameter can be accessed if **[AI2 Type] 𐄂 , 2 𐄂** is not set to

- **[Voltage] 1 0 𐄂**, or
- **[Current] 0 𐄂**, or
- **[PTC Management] P 𐄂 C**.

Setting (𐄂)	Description
-15.0...200.0°C	Setting range <b>Factory setting:</b> 110.0°C

**[AI2 Th Warn Level] 𐄂 H 2 𐄂 ★**

Warning level for AI2.

This parameter can be accessed if **[AI2 Type] 𐄂 , 2 𐄂** is not set to

- **[Voltage] 1 0 𐄂**, or
- **[Current] 0 𐄂**, or
- **[PTC Management] P 𐄂 C**.

Setting (𐄂)	Description
-15.0...200.0°C	Setting range <b>Factory setting:</b> 90.0°C

**[AI2 Th Value] 𐄂 H 2 𐄂 ★**

AI2 thermal value.

This parameter can be accessed if **[AI2 Type] 𐄂 , 2 𐄂** is not set to

- **[Voltage] 1 0 𐄂**, or
- **[Current] 0 𐄂**, or
- **[PTC Management] P 𐄂 C**.

Setting	Description
-15.0...200.0°C	Setting range <b>Factory setting:</b> _



**[AI3 Th Monitoring] E H 3 5**

Activation of the thermal monitoring on AI3.

Setting	Code / Value	Description
[No]	n o	No <b>Factory setting</b>
[YES]	y e 5	Yes

**[AI3 Type] R , 3 E ★**

Configuration of analog input AI3.

This parameter can be accessed if **[AI3 Th Monitoring] E H 3 5** is not set to **[No] n o**.

Identical to **[AI2 Type] R , 2 E** with factory setting: **[Current] D R** (see page 183).

**[AI3 Th Error Resp] E H 3 b ★**

Thermal monitoring response to a detected error for AI3.

This parameter can be accessed if **[AI3 Type] R , 3 E** is not set to

- **[Voltage] I D u**, or
- **[Current] D R**, or

Setting	Code / Value	Description
[Ignore]	n o	Detected error ignored
[Freewheel Stop]	y e 5	Freewheel stop
[Per STT]	5 E E	Stop according to <b>[Type of stop] 5 E E</b> parameter but without an error triggered after stop
[Fallback Speed]	L F F	Change to fallback speed, maintained as long as the detected error persists and the run command has not been removed <sup>(1)</sup>
[Ramp stop]	r P P	Stop on ramp <b>Factory setting</b>
1 Because, in this case, the detected error does not trigger a stop, it is recommended to assign a relay or logic output to its indication.		

**[AI3 Th Error Level] E H 3 F ★**

Error detection level for AI3.

This parameter can be accessed if **[AI3 Type] R , 3 E** is not set to

- **[Voltage] I D u**, or
- **[Current] D R**, or
- **[PTC Management] P E C**.

Setting ( )	Description
-15.0...200.0°C	Setting range <b>Factory setting:</b> 110.0°C

**[AI3 Th Warn Level] E H 3 A ★**

Warning level for AI3.

This parameter can be accessed if **[AI3 Type] R , 3 E** is not set to

- **[Voltage] I D u**, or
- **[Current] D R**, or
- **[PTC Management] P E C**.

Setting ( )	Description
-15.0...200.0°C	Setting range <b>Factory setting:</b> 90.0°C

**[AI3 Th Value] Ɨ H 3 ƭ ★**

AI3 thermal value.

This parameter can be accessed if **[AI3 Type] R , 3 Ɨ** is not set to

- **[Voltage] 1 0 ƭ**, or
- **[Current] 0 R**, or
- **[PTC Management] P Ɨ Ɨ**.

Setting	Description
-15.0...200.0°C	Setting range Factory setting: _

**[AI4 Th Monitoring] Ɨ H 4 5 ★**

Activation of the thermal monitoring on AI4.

This parameter can be accessed if VW3A3203 relay output option module has been inserted.

Setting	Code / Value	Description
[No]	n 0	No Factory setting
[YES]	Ʒ Ɨ 5	Yes

**[AI4 Type] R , 4 Ɨ ★**

AI4 assignment.

This parameter can be accessed if **[AI4 Th Monitoring] Ɨ H 4 5** is not set to **[No] n 0**.

Setting	Code / Value	Description
[Voltage]	1 0 ƭ	0-10 Vdc
[Current]	0 R	0-20 mA
[Voltage +/-]	n 1 0 ƭ	-10/+10 Vdc Factory setting
[PTC Management]	P Ɨ Ɨ	1 to 6 PTC (in serial)
[KTY]	K Ɨ Ʒ	1 KTY84
[PT1000]	1 P Ɨ 3	1 PT1000 connected with 2 wires
[PT100]	1 P Ɨ 2	1 PT100 connected with 2 wires
[3 PT1000]	3 P Ɨ 3	3 PT1000 connected with 2 wires
[3 PT100]	3 P Ɨ 2	3 PT100 connected with 2 wires
[PT1000 in 3 wires]	1 P Ɨ 3 3	1 PT1000 connected with 3 wires (AI4 & AI5 only)
[PT100 in 3 wires]	1 P Ɨ 2 3	1 PT100 connected with 3 wires (AI4 & AI5 only)
[3 PT1000 in 3 wires]	3 P Ɨ 3 3	3 PT1000 connected with 3 wires (AI4 & AI5 only)
[3 PT100 in 3 wires]	3 P Ɨ 2 3	3 PT100 connected with 3 wires (AI4 & AI5 only)

**[AI4 Th Error Resp] E H 4 B ★**

Thermal response to a detected error for AI4.

This parameter can be accessed if **[AI4 Type] R , 4 E** is not set to

- **[Voltage] I D U**, or
- **[Current] D R**.

Setting	Code / Value	Description
<b>[Ignore]</b>	<i>n o</i>	Detected error ignored
<b>[Freewheel Stop]</b>	<i>Y E S</i>	Freewheel stop
<b>[Per STT]</b>	<i>S E E</i>	Stop according to <b>[Type of stop] S E E</b> parameter but without an error triggered after stop
<b>[Fallback Speed]</b>	<i>L F F</i>	Change to fallback speed, maintained as long as the detected error persists and the run command has not been removed <sup>(1)</sup>
<b>[Ramp stop]</b>	<i>r P P</i>	Stop on ramp <b>Factory setting</b>

1 Because, in this case, the detected error does not trigger a stop, it is recommended to assign a relay or logic output to its indication.

**[AI4 Th Error Level] E H 4 F ★**

Error detection level for AI4.

This parameter can be accessed if **[AI4 Type] R , 4 E** is not set to

- **[Voltage] I D U**, or
- **[Current] D R**, or
- **[PTC Management] P E C**.

Setting ( )	Description
-15.0...20.00°C	Setting range <b>Factory setting:</b> 110.0°C

**[AI4 Th Warn Level] E H 4 R ★**

Warning level for AI4.

This parameter can be accessed if **[AI4 Type] R , 4 E** is not set to

- **[Voltage] I D U**, or
- **[Current] D R**, or
- **[PTC Management] P E C**.

Setting ( )	Description
-15.0...200.0°C	Setting range <b>Factory setting:</b> 90.0°C

**[AI4 Th Value] E H 4 U ★**

AI4 thermal value.

This parameter can be accessed if **[AI4 Type] R , 4 E** is not set to

- **[Voltage] I D U**, or
- **[Current] D R**, or
- **[PTC Management] P E C**.

Setting	Description
-15.0...200.0°C	Setting range <b>Factory setting:</b> _

**[AI5 Th Monitoring] Ɛ H 5 5 ★**

Activation of the thermal monitoring on AI5.  
 This parameter can be accessed if VW3A3203 relay output option module has been inserted.

Setting	Code / Value	Description
[No]	n o	No <b>Factory setting</b>
[YES]	Y E 5	Yes

**[AI5 Type] A , 5 Ɛ ★**

AI5 assignment.  
 This parameter can be accessed if **[AI5 Th Monitoring] Ɛ H 5 5** is not set to **[No] n o**.  
 Identical to **[AI4 Type] A , 4 Ɛ** (see page 186).

**[AI5 Th Error Resp] Ɛ H 5 b ★**

Thermal monitoring response to a detected error for AI5.  
 This parameter can be accessed if **[AI5 Type] A , 5 Ɛ** is not set to

- **[Voltage] I D u**, or
- **[Current] D A**.

Setting	Code / Value	Description
[Ignore]	n o	Detected error ignored
[Freewheel Stop]	Y E 5	Freewheel stop
[Per STT]	5 Ɛ Ɛ	Stop according to <b>[Type of stop] 5 Ɛ Ɛ</b> parameter but without an error triggered after stop
[Fallback Speed]	L F F	Change to fallback speed, maintained as long as the detected error persists and the run command has not been removed <sup>(1)</sup>
[Ramp stop]	r P P	Stop on ramp <b>Factory setting</b>
<b>1</b> Because, in this case, the detected error does not trigger a stop, it is recommended to assign a relay or logic output to its indication.		

**[AI5 Th Error Level] Ɛ H 5 F ★**

Error detection level for AI5.  
 This parameter can be accessed if **[AI5 Type] A , 5 Ɛ** is not set to

- **[Voltage] I D u**, or
- **[Current] D A**, or
- **[PTC Management] P Ɛ C**.

Setting (°C)	Description
-15.0...200.0°C	Setting range <b>Factory setting:</b> 110.0°C

**[AI5 Th Warn Level] Ɛ H 5 A ★**

Warning level for AI5.  
 This parameter can be accessed if **[AI5 Type] A , 5 Ɛ** is not set to

- **[Voltage] I D u**, or
- **[Current] D A**, or
- **[PTC Management] P Ɛ C**.

Setting (°C)	Description
-15.0...200.0°C	Setting range <b>Factory setting:</b> 90.0°C

**[AI5 Th Value] Ɨ H 5 ƭ ★**

AI5 thermal value.

This parameter can be accessed if **[AI5 Type] H , 5 Ɨ** is not set to

- **[Voltage] 1 0 ƭ**, or
- **[Current] 0 H**, or
- **[PTC Management] P Ɨ Ɨ**.

Setting	Description
-15.0...200.0°C	Setting range Factory setting: _

## [Motor monitoring] $\Pi \square P$ - Menu

### Access

[Complete settings] → [Motor parameters] → [Motor monitoring]

### About This Menu

The thermal monitoring function helps to prevent the motor from overheating by an estimation of the thermal state of the motor.

## [Current Limitation] $C L$ , ★

Internal current limit.

<b>NOTICE</b>
<p><b>OVERHEATING AND DAMAGE TO THE MOTOR</b></p> <ul style="list-style-type: none"> <li>• Verify that the motor is properly rated for the maximum current to be applied to the motor.</li> <li>• Consider the duty cycle of the motor and all factors of your application including derating requirements in determining the current limit.</li> </ul> <p><b>Failure to follow these instructions can result in equipment damage.</b></p>

**NOTE:** If the setting is less than 0.25. In, the drive may lock in [OutPhaseLoss Assign]  $\square P L$  if this has been enabled. If it is less than the no-load motor current, the motor cannot run.

Setting ( )	Description
0...1.2 In <sup>(1)</sup>	Setting range <b>Factory setting:</b> 1.2 In <sup>(1)</sup>
(1) Corresponding to the rated drive current indicated in the installation manual and on the drive nameplate.	

## [Attenuation Time] $S \square P$ ★

Attenuation time.

This parameter can be accessed if [Motor surge limit.]  $S V L$  is not set to [No]  $n \square$ .

The value of the [Volt surge limit. opt]  $S \square P$  parameter corresponds to the attenuation time of the cable used. It is defined to help to prevent the superimposition of voltage wave reflections resulting from long cable lengths. It limits over-voltages to twice the DC bus rated voltage.

As surge voltage depends on many parameters such as types of cable, different motor powers in parallel, different cable lengths in parallel, and so on, it is recommend the use of an oscilloscope to check the over-voltage values obtained at the motor terminals.

For long cable lengths, an output of the filter or a dV/dt protection filter must be used.

To retain the overall drive performance, do not increase the SOP value unnecessarily.

Setting	Code / Value	Description
[6]	$6$	6 $\mu s$
[8]	$8$	8 $\mu s$ <b>Factory setting</b>
[10]	$10$	10 $\mu s$

**[Sinus Filter Activation] 0 F , ★**

Sinus filter activation.

This parameter can be accessed if **[Motor Control Type] 0 0 0** is not set to **[SYN\_U VC] 5 0 0**.

**NOTICE****RISK OF DAMAGE TO THE SINUS FILTER**

On systems using a sinus filter, the maximum output frequency **[Max frequency] 0 F r** must not exceed 100 Hz.

**Failure to follow these instructions can result in equipment damage.**

Setting	Code / Value	Description
[No]	0 0	No sinus filter <b>Factory setting</b>
[Yes]	0 0 5	Use of a sinus filter to limit over-voltages on the motor and reduce the ground detected error leakage current.

**[Output Short Circuit Test] 5 0 r 0**

Output short circuit test configuration.

The drive outputs are tested on power-up and every time a run command is applied. These tests cause a slight delay (a few ms). In the event of an error, the drive locks.

The *drive output short-circuit (terminals U-V-W): SCF display* error can be detected.

Setting	Code / Value	Description
[No]	0 0	No test
[Yes]	0 0 5	Output short circuit test enabled <b>Factory setting</b>

**[Motor control] d r C - Menu**

**Access**

[Complete settings] → [Motor parameters] → [Motor control]

**[IR compensation] u F r**

This parameter is used to optimize torque at low speed, or to adapt to special cases (for example: for motors connected in parallel, decrease [IR compensation] u F r). If there is insufficient torque at low speed, increase [IR compensation] u F r. A too high value can avoid the motor to start (locking) or change the current limiting mode.

Setting ( )	Description
0...200%	Setting range Factory setting: 100%

**[Slip compensation] 5 L P ★**

Slip compensation.

This parameter cannot be accessed if [Motor Control Type] C E E is set to [SYN\_U VC] 5 9 n u.

This parameter is set to 0% when [Motor Control Type] C E E is set to [U/F VC Quad.] u F 9.

The speeds given on motor nameplates are not necessarily exact.

If the slip setting is lower than the actual slip, the motor is not rotating at the correct speed in steady state, but at a lower speed than the reference.

If the slip setting is higher than the actual slip, the motor is overcompensated and the speed is unstable.

Setting ( )	Description
0...300%	Setting range Factory setting: 100%

**[U/F Profile] P F L ★**

U/F profile.

This parameter can be accessed if [Motor Control Type] C E E is set to [U/F VC Quad.] u F 9.

This parameter is used to adjust the fluxing current level at zero speed, in % of nominal motor current at nominal speed.

Setting ( )	Description
0...100%	Setting range Factory setting: 30%

**[U1] u 1 ★**

Voltage point 1 on 5 points V/F.

This parameter can be accessed if [Motor Control Type] C E E is set to [V/F 5pts] u F 5.

Setting ( )	Description
0...800 Vac	Setting range according to rating Factory setting: 0 Vac



**[U2]** ⌵ 2 ★

Voltage point 2 on 5 points V/F.

V/F profile setting.

This parameter can be accessed if **[Motor Control Type]** *C L E* is set to **[V/F 5pts]** ⌵ F 5.

Setting (⌵)	Description
0...800 Vac	Setting range according to rating <b>Factory setting:</b> 0 Vac

**[U3]** ⌵ 3 ★

Voltage point 3 on 5 points V/F.

V/F profile setting.

This parameter can be accessed if **[Motor Control Type]** *C L E* is set to **[V/F 5pts]** ⌵ F 5.

Setting (⌵)	Description
0...800 Vac	Setting range according to rating <b>Factory setting:</b> 0 Vac

**[U4]** ⌵ 4 ★

Voltage point on 4 points V/F.

V/F profile setting.

This parameter can be accessed if **[Motor Control Type]** *C L E* is set to **[V/F 5pts]** ⌵ F 5.

Setting (⌵)	Description
0...800 Vac	Setting range according to rating <b>Factory setting:</b> 0 Vac

**[U5]** ⌵ 5 ★

Voltage point 5 on 5 points V/F.

V/F profile setting.

This parameter can be accessed if **[Motor Control Type]** *C L E* is set to **[V/F 5pts]** ⌵ F 5.

Setting (⌵)	Description
0...800 Vac	Setting range according to rating <b>Factory setting:</b> 0 Vac

**[F1]** F 1 ★

Frequency point 1 on 5 points V/F.

V/F profile setting.

This parameter can be accessed if **[Motor Control Type]** *C L E* is set to **[V/F 5pts]** ⌵ F 5.

Setting (⌵)	Description
0.0...500.0 Hz	Setting range <b>Factory setting:</b> 0.0 Hz

**[F2] F 2 ★**

Frequency point 2 on 5 points V/F.

V/F profile setting.

This parameter can be accessed if **[Motor Control Type] C L E** is set to **[V/F 5pts] u F 5**.

Setting ( )	Description
0.0...500.0 Hz	Setting range <b>Factory setting:</b> 0.0 Hz

**[F3] F 3 ★**

Frequency point 3 on 5 points V/F.

V/F profile setting.

This parameter can be accessed if **[Motor Control Type] C L E** is set to **[V/F 5pts] u F 5**.

Setting ( )	Description
0.0...500.0 Hz	Setting range <b>Factory setting:</b> 0.0 Hz

**[F4] F 4 ★**

Frequency point 4 on 5 points V/F.

V/F profile setting.

This parameter can be accessed if **[Motor Control Type] C L E** is set to **[V/F 5pts] u F 5**.

Setting ( )	Description
0.0...500.0 Hz	Setting range <b>Factory setting:</b> 0.0 Hz

**[F5] F 5 ★**

Frequency point 5 on 5 points V/F.

V/F profile setting.

This parameter can be accessed if **[Motor Control Type] C L E** is set to **[V/F 5pts] u F 5**.

Setting ( )	Description
0.0...500.0 Hz	Setting range <b>Factory setting:</b> 0.0 Hz

**[Output Ph Rotation] P H r**

Output phase rotation.

Modifying this parameter operates as an inversion of 2 of the three motor phases. This results in changing the direction of rotation of the motor.

Setting	Code / Value	Description
[ABC]	A B C	Standard rotation <b>Factory setting</b>
[ACB]	A C B	Opposite rotation

**[Inertia Factor]  $SPGU$  ★**

Inertia factor for following motor control types.

This parameter can be accessed if:

- **[Access Level]  $LRC$**  is set to **[Expert]  $EP_r$** , and
- **[Motor Control Type]  $CLL$**  is set to **[U/F VC 5pts]  $UF_5$** , or **[U/F VC Quad.]  $UF_9$** , or **[SYN\_U VC]  $SYNU$** .

Setting ( )	Description
0...1,000%	Setting range Factory setting: 40%

**[Boost Activation]  $BOA$  ★**

Boost activation.

This parameter can be accessed if **[Access Level]  $LRC$**  is set to **[Expert]  $EP_r$** .

Setting	Code / Value	Description
<b>[Inactive]</b>	$NO$	No boost Factory setting
<b>[Dynamic]</b>	$dynA$	Dynamic boost, the magnetizing current value is modified according to the motor load, can be accessed if <b>[Motor Control Type] <math>CLL</math></b> is not set to <b>[SYN_U VC] <math>SYNU</math></b>
<b>[Static]</b>	$StA$	Static boost, the magnetizing current value follows the profile whatever the motor load
<b>[Constant]</b>	$CLL$	Constant boost, can be accessed if <b>[Motor Control Type] <math>CLL</math></b> is set to <b>[SYN_U VC] <math>SYNU</math></b>

**[Boost]  $BOB$  ★**

Value at 0 Hz: % of nominal magnetizing current (taken into account if different from 0).

A too high value of **[Boost]  $BOB$**  can result in a magnetic saturation of the motor, which leads to a torque reduction.

This parameter can be accessed if:

- **[Access Level]  $LRC$**  is set to **[Expert]  $EP_r$** , and
- **[BOA]  $BOA$**  is not set to **[NO]  $NO$** .

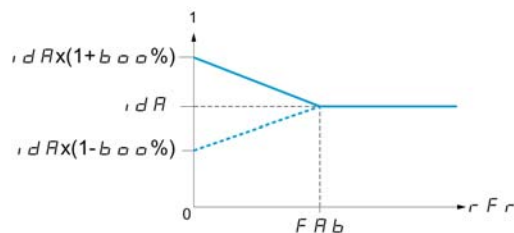

Setting	Description
-100...100%	Setting range If <b>[Boost Activation] <math>BOA</math></b> is set to <b>[Dynamic] <math>dynA</math></b> , <b>[BOOST] <math>BOB</math></b> is set to 25%. Factory setting: 0%

**[Freq Boost] F R b** ★

Value at 0 Hz: speed threshold to reach nominal magnetizing current.

This parameter can be accessed if:

- **[Access Level] L R C** is set to **[Expert] E P r**, and
- **[BOA] b o A** is not set to **[Inactive] n o**.

Setting	Description
0.0...500.0 Hz	Setting range If <b>[Boost Activation] b o A</b> is set to <b>[Dynamic] d y n A</b> , <b>[FAB] F R b</b> is set to 30.0 Hz. <b>Factory setting:</b> 0.0 Hz

## [Switching frequency] *S F F* - Menu

### Access

[Complete settings] → [Motor parameters] → [Switching frequency]

### [Switching frequency] *S F r*

Drive switching frequency.

Adjustment range: The maximum value is limited to 4 kHz if [Motor surge limit.] *S u L* parameter is configured.

If [Sinus Filter Activation] *s F i* is set to [Yes] *Y E S*, the minimum value is 2 kHz and the maximum value is limited to 6 kHz or 8 kHz according to drive rating.

**NOTE:** In the event of excessive temperature rise, the drive automatically reduces the switching frequency and reset it once the temperature returns to normal.

In case of high-speed motor, it is advised to increase the PWM frequency [Switching frequency] *S F r* at 8, 12 kHz or 16 kHz

Setting ( )	Description
1...8 or 16 kHz according to drive rating	Setting range <b>Factory setting:</b> 4.0 kHz or 2.5 kHz according to the drive rating

### [Noise Reduction] *n r d*

Motor noise reduction.

Random frequency modulation helps to prevent any resonance, which may occur at a fixed frequency.

Setting	Code / Value	Description
[No]	<i>n o</i>	Fixed frequency <b>Factory setting</b>
[Yes]	<i>Y E S</i>	Frequency with random modulation

### [Switch Freq Type] *S F t* ★

Switching frequency type.

This parameter can be accessed if [Access Level] *L A C* is set to [Expert] *E P r*.

The motor switching frequency is modified (reduced) when the internal temperature of the drive is too high.

Setting ( )	Code / Value	Description
[SFR type 1]	<i>H F 1</i>	Heating optimization Allows the system to adapt the switching frequency according to the motor frequency. This setting optimizes the heating loss of the drive in order to improve the drive efficiency. <b>Factory setting</b>
[SFR type 2]	<i>H F 2</i>	Allows the system to keep a constant chosen switching frequency [Switching frequency] <i>S F r</i> whatever the motor frequency [Output frequency] <i>r F r</i> . With this setting, the motor noise is kept as low as possible for a high switching frequency. In the event of overheating, the drive automatically decreases the switching frequency. It is restored to its original value when the temperature returns to normal.

**[Motor Surge Limit.] 5  $\mu$  L**

Surge voltage limitation.

This function limits motor over-voltages and is useful in the following applications:

- NEMA motors
- Old or poor quality motors
- Spindle motors
- Rewound motors

This parameter can remain set to **[No] n 0** for 230/400 Vac motors used at 230 Vac, or if the length of cable between the drive and the motor does not exceed:

- 4 m with unshielded cables
- 10 m with shielded cables

**NOTE:** When **[Motor Surge Limit.] 5  $\mu$  L** is set to **[Yes] 4 E 5**, the maximum switching frequency **[Switching freq.] 5 F r** is modified.

Setting	Code / Value	Description
<b>[No]</b>	<b>n 0</b>	Function inactive <b>Factory setting</b>
<b>[Yes]</b>	<b>4 E 5</b>	Function active

**[Attenuation Time] 5  $\mu$  P ★**

Attenuation time.

The value of the **[Volt surge limit. opt] 5  $\mu$  P** parameter corresponds to the attenuation time of the cable used. It has been defined to prevent the superimposition of voltage wave reflections resulting from long cable lengths. It limits over-voltages to twice the DC bus rated voltage.

As surge voltage depends on many parameters such as types of cable, different motor powers in parallel, different cable lengths in parallel, and so on, It is recommended use an oscilloscope to check the over-voltage values obtained at the motor terminals.

For long cable lengths, an output of the filter or a dV/dt protection filter must be used.

To retain the overall drive performance, do not increase the **5  $\mu$  P** value unnecessarily.

Setting	Code / Value	Description
<b>[6]</b>	<b>6</b>	6 $\mu$ s
<b>[8]</b>	<b>8</b>	8 $\mu$ s <b>Factory setting</b>
<b>[10]</b>	<b>10</b>	10 $\mu$ s

## Section 7.4

### [Define system units]

#### [Define system units] 5 4 C - Menu

##### Access

[Complete settings] → [Define system units]

##### About This Menu

In order to be easy to configure, commission, operate, and maintain, the drive uses the application units.

The physicals that are concerned by application units are:

- Pressure values
- Flow rate values
- Temperature values
- Currency values

**NOTE:** Some other default system units are automatically deduced from configurable system units or from other parameters.

System unit applies by default to all communication parameters and HMI (Graphic Display Terminal, Web server, DTM-based software).

When a system unit is changed, there is no rescaling of values. Numerical values are kept, but the meaning of these values is not the same:

- After a change, the behavior of the product will not change (the system stays numerically the same).
- If new values are written through communication or through HMI in new unit, then the behavior is impacted. In that case, all parameters should be reconfigured according to the new selected unit.
- In order to avoid issues due to a modification of system unit parameters, system units should be modified only during the installation of the product and before the commissioning of the functions.

The precision of the physical values is selected at the same time as the unit.

By default, values are signed.

Default range of values are:

16 bits values	32 bits values
-32,768...32,767	-2,147,483,648...2,147,483,648

**[P sensor unit] 5 u P r**

Default system application unit used for pressure.

Available pressure units:

Unit	Symbol	Conversion
Kilo Pascal	kPa	100 kPa = 1 bar
Millibar	mbar	
Bar	bar	
Pound / square inch (lb/in <sup>2</sup> )	psi psig	14.5 psi = 1 bar
Inch H2O Inch water gauge Inch water column	inH2O inWG inWC	1 inH2O 4°C = 0.0024908891 bar (0.036127292 psi)
Feet water gauge Feet water column Feet	ftWG ftWC ft	1 inH2O 4°C = 0.0298906692 bar (0.433527504 psi)
Meter water gauge Meter water column Meter	mWG mWC (mCE) m	1 mH2O(4°C) = 0.0980665 bar (1.42233433 psi)
Inch of mercury	inHg	1 inHg = 0.0338638864 bar (0.491154147 psi)
Percentage	%	–
w/o unit	–	–

Setting	Code / Value	Description
[1Kpa]	<i>P R</i>	1 kpa
[1mbar]	<i>1 m b a r</i>	1 mbar
[1Bar]	<i>b a r</i>	1 bar
[0.1Bar]	<i>0.1 b a r</i>	0.1 bar <b>Factory setting</b>
[0.01Bar]	<i>0.01 b a r</i>	0.01 bar
[1 PSI]	<i>P S i</i>	1 Psi
[0.1 PSI]	<i>0.1 P S i</i>	0.1 psi
[1 PSIG]	<i>P S i G</i>	1 Psig
[0.1 PSIG]	<i>0.1 P S i G</i>	0.1 Psig
[1inH2O]	<i>1 i n H 2 O</i>	1 inH2O
[1inWg]	<i>1 i n W G</i>	1 inWg
[1inWC]	<i>1 i n W C</i>	1 inWc
[1 FtWg]	<i>1 F t W G</i>	1 FtWg
[1 FtWC]	<i>1 F t W C</i>	1 FtWC
[1 Ft]	<i>1 F t</i>	1 Ft
[1 MWG]	<i>1 m W G</i>	1 mWg
[0.1 MWG]	<i>0.1 m W G</i>	0.1 mWg
[1 MWC]	<i>1 m W C</i>	1 mWC
[0.1 MWC]	<i>0.1 m W C</i>	0.1 mWC
[1m]	<i>1 m</i>	1 m
[0.1 m]	<i>0.1 m</i>	0.1 m
[1 inHG]	<i>1 i n H G</i>	1 inHg
[0.1%]	<i>0.1 %</i>	0.1%
[0.1]	<i>0.1 w / o</i>	0.1 w/o



**[Flow rate unit] 5 U F r**

Default system application unit used for flow rate.

Available flow units:

Unit	Symbol	Conversion
Liter / second	l/s	–
Liter / minute	l/min	–
Liter / hour	l/h	–
Cubic decimeter / minute	dm <sup>3</sup> /min	–
Cubic meter / second	m <sup>3</sup> /s	–
Cubic meter / minute	m <sup>3</sup> /min	–
Cubic meter / hour	m <sup>3</sup> /h	–
Gallon per second	gal/s	1 usgal = 3,785411784 l
Gallon per minute	gal/min; GPM	–
Gallon per hour	gal/h	–
Cubic feet / second	ft <sup>3</sup> /s	1 ft <sup>3</sup> = 28.317 l
Cubic feet / minute	ft <sup>3</sup> /min; CFM, SCFM	–
Cubic feet / hour	ft <sup>3</sup> /h	–
Percentage	%	–
w/o unit	–	–

Setting	Code / Value	Description
[1 L/s]	IL S	L/s
[l/s]	0 IL S	0.1 L/s
[1 L/m]	IL n	L/m
[1 L/h]	IL h	L/h
[1 dm <sup>3</sup> /mn]	ld n n n	d <sup>3</sup> /m
[1 m <sup>3</sup> /s]	ln s s	M <sup>3</sup> /s
[0.1 m <sup>3</sup> /s]	0 ln s s	0.1 M <sup>3</sup> /s
[1m <sup>3</sup> /m]	ln n n n	M <sup>3</sup> /min
[0.1 m <sup>3</sup> /m]	0 ln n n n	0.1 M <sup>3</sup> /min
[1 m <sup>3</sup> /h]	ln s h	1 M <sup>3</sup> /h
[0.1m <sup>3</sup> /h]	0 ln s h	0.1 M <sup>3</sup> /h <b>Factory setting</b>
[1 gal/s]	IG P S	1 Gal/s
[1 GPM]	IG P n	1 GPM
[1 gal/h]	IG P H	1 Gal/h
[1 ft <sup>3</sup> /s]	IC F S	1 ft <sup>3</sup> /s
[1CFM]	IC F n	1 CFM
[1SCFM]	IS C F n	1 SCFM
[1 Ft <sup>3</sup> /h]	IC F H	1 ft <sup>3</sup> /h
[1 Kg/s]	IG S	1 kg/s
[1 Kg/m]	IG n	1 kg/m
[1 Kg/h]	IG H	1 kg/h
[1 Lb/s]	IL b S	1 lb/s
[1 Lb/m]	IL b n	1 lb/m
[1 Lb/h]	IL b H	1 lb/h
[0.1%]	0 IPC	0.1%
[0.1]	0 IW o	0.1 w/o

**[Temperature unit] S U T P**

Default system application unit used for temperature.

Available temperature units:

Unit	Symbol	Conversion
Celsius Degree	°C	–
Fahrenheit Degree	°F	$TF = 9/5 * Tc + 32$
Percentage	%	–
w/o unit	–	–

Setting	Code / Value	Description
[0.1°C]	<i>D. 1°C</i>	0.1 °C <b>Factory setting</b>
[0.1°F]	<i>D. 1°F</i>	0.1 °F
[0.1%]	<i>D. 1%</i>	0.1%
[0.1]	<i>D. 1 w/o</i>	0.1 w/o

**[Currency unit list] S U C U**

Default system application unit used for currency.

Setting	Code / Value	Description
[EURO]	<i>E u r o</i>	Euro <b>Factory setting</b>
[\$]	<i>\$</i>	Dollar
[£]	<i>£</i>	Pound
[Krone]	<i>K r</i>	Krone
[Renminbi]	<i>r n b</i>	Renminbi
[Other]	<i>o t h e r</i>	Other

**[Liquid Density] r H o**

Density of the fluid to be pumped.

This parameter can be accessed if **[Access Level] L H C** is not set to **[Expert] E P r**.

Setting	Description
100...10,000 kg/m3	Setting range <b>Factory setting:</b> 1000 kg/m3

## Section 7.5

### [Sensors assignment]

#### What Is in This Section?

This section contains the following topics:

Topic	Page
[Sensors assignment] <i>5 C C</i> - Menu	204
[AI1 sensor config.] <i>LCR 1</i> - Menu	205
[AI2 sensor config.] <i>LCR 2</i> - Menu	207
[AI3 sensor config.] <i>LCR 3</i> - Menu	208
[AI4 sensor config.] <i>LCR 4</i> - Menu	209
[AI5 sensor config.] <i>LCR 5</i> - Menu	211
[AIV1 sensor config.] <i>LCU 1</i> - Menu	212
[Sensors assignment] <i>5 C C</i> - Menu	213
[AI1 sensor config.] <i>o LCR 1</i> - Menu	214
[AI2 sensor config.] <i>o LCR 2</i> - Menu	216
[AI3 sensor config.] <i>o LCR 3</i> - Menu	217
[AI4 sensor config.] <i>o LCR 4</i> - Menu	218
[AI5 sensor config.] <i>o LCR 5</i> - Menu	219
[AIV1 sensor config.] <i>o LCU 1</i> - Menu	220
[Sensors assignment] <i>5 C C</i> - Menu	221
[AI1 sensor config.] <i>LF 1</i> - Menu	222
[AI2 sensor config.] <i>LF 2</i> - Menu	224
[AI3 sensor config.] <i>LF 3</i> - Menu	225
[AI4 sensor config.] <i>LF 4</i> - Menu	226
[AI5 sensor config.] <i>LF 5</i> - Menu	227
[DI5 Pulse Sensor Config.] <i>LF B</i> - Menu	228
[DI6 Pulse Sensor Config.] <i>LF 9</i> - Menu	229
[AIV1 sensor config.] <i>LFV 1</i> - Menu	230
[Sensors assignment] <i>5 C C</i> - Menu	231
[AI1 sensor config.] <i>PF 1</i> - Menu	232
[AI2 sensor config.] <i>PF 2</i> - Menu	234
[AI3 sensor config.] <i>PF 3</i> - Menu	236
[AI4 sensor config.] <i>PF 4</i> - Menu	237
[AI5 sensor config.] <i>PF 5</i> - Menu	239
[DI5 configuration] <i>PF B</i> - Menu	240
[DI6 configuration] <i>PF 9</i> - Menu	241
[AIV1 configuration] <i>PFV 1</i> - Menu	242
[Sensors assignment] <i>5 C C</i> - Menu	243
[AI1 configuration] <i>L C R 1</i> - Menu	244
[AI2 configuration] <i>L C R 2</i> - Menu	246
[AI3 configuration] <i>L C R 3</i> - Menu	247
[AI4 configuration] <i>L C R 4</i> - Menu	248
[AI5 configuration] <i>L C R 5</i> - Menu	249
[AIV1 configuration] <i>L C U 1</i> - Menu	250

**[Sensors assignment] 5 [ ] - Menu****Access**

**[Complete settings] → [Sensors assignment]**

**About This Menu**

This menu is used to set the sensors.

In case of mixing absolute and relative sensors, verify the consistency between all sensor data and adjust if necessary by using the process value scaling and the analog inputs operation functions.

**[InletPres Assign] P 5 I A**

Inlet pressure sensor assignment.

Setting	Code / Value	Description
<b>[Not Configured]</b>	<i>n o</i>	Not assigned <b>Factory setting</b>
<b>[AI1]...[AI3]</b>	<i>R , 1...R , 3</i>	Analog input AI1...AI3
<b>[AI4]...[AI5]</b>	<i>R , 4...R , 5</i>	Analog input AI4...AI5 if VW3A3203 I/O extension module has been inserted
<b>[AI Virtual 1]</b>	<i>R , V 1</i>	Virtual analogic input 1

## [AI1 sensor config.] , [R] I - Menu

### Access

[Complete settings] → [Sensors assignment] → [AI1 sensor config.]

### About This Menu

Following parameters can be accessed if [InletPres Assign] P 5 I R is set to [AI1] R , I .

### [AI1 Type] R , I E

Configuration of analog input AI1.

Setting	Code / Value	Description
[Voltage]	I 0 u	0-10 Vdc <b>Factory setting</b>
[Current]	0 R	0-20 mA

### [AI1 min value] u , L I ★

AI1 voltage scaling parameter of 0%.

This parameter can be accessed if [AI1 Type] R , I E is set to [Voltage] I 0 u .

Setting	Description
0.0...10.0 Vdc	Setting range <b>Factory setting:</b> 0.0 Vdc

### [AI1 max value] u , H I ★

AI1 voltage scaling parameter of 100%.

This parameter can be accessed if [AI1 Type] R , I E is set to [Voltage] I 0 u .

Setting	Description
0.0...10.0 Vdc	Setting range <b>Factory setting:</b> 10.0 Vdc

### [AI1 min. value] C r L I ★

AI1 current scaling parameter of 0%.

This parameter can be accessed if [AI1 Type] R , I E is set to [Current] 0 R .

Setting	Description
0.0...20.0 mA	Setting range <b>Factory setting:</b> 0.0 mA

### [AI1 max. value] C r H I ★

AI1 current scaling parameter of 100%.

This parameter can be accessed if [AI1 Type] R , I E is set to [Current] 0 R .

Setting	Description
0.0...20.0 mA	Setting range <b>Factory setting:</b> 20.0 mA

**[A11 Lowest Process] R , I J**

A11 lowest process.

Setting	Description
-32,767...32,767	Setting range. Value in application customer unit. <b>Factory setting:</b> 0

**[A11 Highest Process] R , I K**

A11 highest process.

Setting	Description
-32,767...32,767	Setting range. Value in application customer unit <b>Factory setting:</b> 0

## [AI2 sensor config.] , L R 2 - Menu

### Access

[Complete settings] → [Sensors assignment] → [AI2 sensor config.]

### About This Menu

Following parameters can be accessed if [InletPres Assign] P 5 I R is set to [AI2] R , 2.

### [AI2 Type] R , 2 L

Configuration of analog input AI2.

Setting	Code / Value	Description
[Voltage]	I 0 U	0-10 Vdc <b>Factory setting</b>
[Current]	0 R	0-20 mA
[PTC Management]	P L C	1 to 6 PTC (in serial)
[KTY]	K L Y	1 KTY84
[PT1000]	I P L 3	1 PT1000 connected with 2 wires
[PT100]	I P L 2	1 PT100 connected with 2 wires
[Water Prob]	L E U E L	Water level
[3PT1000]	3 P L 3	3 PT1000 connected with 2 wires
[3PT100]	3 P L 2	3 PT100 connected with 2 wires

### [AI2 min value] U , L 2 ★

AI2 voltage scaling parameter of 0%.

This parameter can be accessed if [AI2 Type] R , 2 L is set to [Voltage] I 0 U.

Identical to [AI1 min value] U , L 1 (see page 205).

### [AI2 max value] U , H 2 ★

AI2 voltage scaling parameter of 100%.

This parameter can be accessed if [AI2 Type] R , 2 L is set to [Voltage] I 0 U.

Identical to [AI1 max value] U , H 1 (see page 205).

### [AI2 min. value] C r L 2 ★

AI2 current scaling parameter of 0%.

This parameter can be accessed if [AI2 Type] R , 2 L is set to [Current] 0 R.

Identical to [AI1 min. value] C r L 1 (see page 205).

### [AI2 max. value] C r H 2 ★

AI2 current scaling parameter of 100%.

This parameter can be accessed if [AI2 Type] R , 2 L is set to [Current] 0 R.

Identical to [AI1 max. value] C r H 1 (see page 205).

### [AI2 Lowest Process] R , 2 J

AI2 lowest process.

Identical to [AI1 Lowest Process] R , 1 J (see page 206).

### [AI2 Highest Process] R , 2 K

AI2 highest process.

Identical to [AI1 Highest Process] R , 1 K (see page 206).

**[AI3 sensor config.] , C R 3 - Menu****Access**

[Complete settings] → [Sensors assignment] → [AI3 sensor config.]

**About This Menu**

Following parameters can be accessed if [InletPres Assign] P 5 I R is set to [AI3] R , 3 .

**[AI3 Type] R , 3 E**

Configuration of analog input AI3.

Identical to [AI2 Type] R , 2 E with factory setting: [Current] 0 R. (see page 207)

**[AI3 min value] 0 , L 3 ★**

AI3 voltage scaling parameter of 0%.

This parameter can be accessed if [AI3 Type] R , 3 E is set to [Voltage] 1 0 0 .

Identical to [AI1 min value] 0 , L 1 (see page 205).

**[AI3 max value] 0 , H 3 ★**

AI3 voltage scaling parameter of 100%.

This parameter can be accessed if [AI3 Type] R , 3 E is set to [Voltage] 1 0 0 .

Identical to [AI1 max value] 0 , H 1 (see page 205).

**[AI3 min. value] C r L 3 ★**

AI3 current scaling parameter of 0%.

This parameter can be accessed if [AI3 Type] R , 3 E is set to [Current] 0 R.

Identical to [AI1 min. value] C r L 1 (see page 205).

**[AI3 max. value] C r H 3 ★**

AI3 current scaling parameter of 100%.

This parameter can be accessed if [AI3 Type] R , 3 E is set to [Current] 0 R.

Identical to [AI1 max. value] C r H 1 (see page 205).

**[AI3 Lowest Process] R , 3 J**

AI3 lowest process.

Identical to [AI1 Lowest Process] R , 1 J (see page 206).

**[AI3 Highest Process] R , 3 K**

AI3 highest process.

Identical to [AI1 Highest Process] R , 1 K (see page 206).



**[AI4 sensor config.] , L H 4 - Menu****Access**

[Complete settings] → [Sensors assignment] → [AI4 sensor config.]

**About This Menu**

Following parameters can be accessed if VW3A3203 I/O extension module has been inserted and if [InletPres Assign] P S I H is set to [AI4] H , 4.

**[AI4 Type] H , 4 E ★**

Configuration of analog input AI4.

This parameter can be accessed if VW3A3203 I/O extension module has been inserted.

Setting	Code / Value	Description
[Voltage]	I D U	0-10 Vdc
[Current]	D H	0-20 mA
[Voltage +/-]	n I D U	-10/+10 Vdc <b>Factory setting</b>
[PTC Management]	P E C	1 to 6 PTC (in serial)
[KTY]	K E Y	1 KTY84
[PT1000]	I P E 3	1 PT1000 connected with 2 wires
[PT100]	I P E 2	1 PT100 connected with 2 wires
[3 PT1000]	3 P E 3	3 PT1000 connected with 2 wires
[3 PT100]	3 P E 2	3 PT100 connected with 2 wires
[PT1000 in 3 wires]	I P E 3 3	1 PT1000 connected with 3 wires (AI4 & AI5 only)
[PT100 in 3 wires]	I P E 2 3	1 PT100 connected with 3 wires (AI4 & AI5 only)
[3 PT1000 in 3 wires]	3 P E 3 3	3 PT1000 connected with 3 wires (AI4 & AI5 only)
[3 PT100 in 3 wires]	3 P E 2 3	3 PT100 connected with 3 wires (AI4 & AI5 only)

**[AI4 min value] U , L 4 ★**

AI4 voltage scaling parameter of 0%.

Identical to [AI1 min value] U , L 1 (see page 205).

**[AI4 max value] U , H 4 ★**

AI4 voltage scaling parameter of 100%.

Identical to [AI1 max value] U , H 1 (see page 205).

**[AI4 min. value] C r L 4 ★**

AI4 current scaling parameter of 0%.

Identical to [AI1 min. value] C r L 1 (see page 205).

**[AI4 max. value] C r H 4 ★**

AI4 current scaling parameter of 100%.

Identical to [AI1 max. value] C r H 1 (see page 205).

**[AI4 Lowest Process] R , 4 J**

A14 lowest process.

Identical to **[AI1 Lowest Process] R , 1 J** (*see page 206*).

**[AI4 Highest Process] R , 4 K**

A14 highest process.

Identical to **[AI1 Highest Process] R , 1 K** (*see page 206*).

## [AI5 sensor config.] , C H 5 - Menu

### Access

[Complete settings] → [Sensors assignment] → [AI5 sensor config.]

### About This Menu

Following parameters can be accessed if VW3A3203 I/O extension module has been inserted and if [InletPres Assign] P 5 I H is set to [AI5] H , 5 .

### [AI5 Type] H , 5 E ★

Configuration of analog input AI5.

This parameter can be accessed if VW3A3203 I/O extension module has been inserted.

Identical to [AI4 Type] H , 4 E (see page 209).

### [AI5 min value] U , L 5 ★

AI5 voltage scaling parameter of 0%.

Identical to [AI1 min value] U , L 1 (see page 205).

### [AI5 max value] U , H 5 ★

AI5 voltage scaling parameter of 100%.

Identical to [AI1 max value] U , H 1 (see page 205).

### [AI5 min. value] C r L 5 ★

AI5 current scaling parameter of 0%.

Identical to [AI1 min. value] C r L 1 (see page 205).

### [AI5 max. value] C r H 5 ★

AI5 current scaling parameter of 100%.

Identical to [AI1 max. value] C r H 1 (see page 205).

### [AI5 Lowest Process] H , 5 J

AI5 lowest process.

Identical to [AI1 Lowest Process] H , 1 J (see page 206).

### [AI5 Highest Process] H , 5 K

AI5 highest process.

Identical to [AI1 Highest Process] H , 1 K (see page 206).

**[AIV1 sensor config.]** , [ C U ] - Menu**Access**

[Complete settings] → [Sensors assignment] → [AIV1 sensor config.]

**About This Menu**

Following parameters can be accessed if [InletPres Assign] P 5 I A is set to [AI Virtual 1] A , U I .

**[AIV1 Channel Assignment] A , C I**

Channel assignment for virtual analog input AIV1.

Setting	Code / Value	Description
[Not Configured]	n a	Not assigned <b>Factory setting</b>
[Ref. Freq-Modbus]	Π d b	Reference frequency via Modbus
[Ref. Freq-CANopen]	C R n	Reference frequency via CANopen if a CANopen module has been inserted
[Ref. Freq-Com. Module]	n E E	Reference frequency via fieldbus module if a fieldbus module has been inserted
[Embedded Ethernet]	E E H	Embedded Ethernet

**[AIV1 Lowest Process] A U I J**

AI virtual: minimum process value.

Setting	Description
-32,767...32,767	Setting range <b>Factory setting:</b> 0

**[AIV1 Highest Process] A U I K**

AI virtual x: maximum process value.

Setting	Description
-32,767...32,767	Setting range <b>Factory setting:</b> 0

**[Sensors assignment] 5 2 2 - Menu****Access****[Complete settings] → [Sensors assignment]****[OutletPres Assign] P 5 2 R**

Outlet pressure sensor assignment.

Setting	Code / Value	Description
[Not Configured]	n o	Not assigned <b>Factory setting</b>
[AI1]...[AI3]	R , 1...R , 3	Analog input AI1...AI3
[AI4]...[AI5]	R , 4...R , 5	Analog input AI4...AI5 if VW3A3203 I/O extension module has been inserted
[AI Virtual 1]	R , V 1	Virtual analogic input 1

**[AI1 sensor config.]** **C R I - Menu****Access****[Complete settings] → [Sensors assignment] → [AI1 sensor config.]****[AI1 Type] R , I E**

Configuration of analog input AI1.

Setting	Code / Value	Description
<b>[Voltage]</b>	<b>I D u</b>	0-10 Vdc <b>Factory setting</b>
<b>[Current]</b>	<b>D R</b>	0-20 mA

**[AI1 min value] u , L I ★**

AI1 voltage scaling parameter of 0%.

This parameter can be accessed if **[AI1 Type] R , I E** is set to **[Voltage] I D u**.

Setting	Description
0.0...10.0 Vdc	Setting range <b>Factory setting:</b> 0.0 Vdc

**[AI1 max value] u , H I ★**

AI1 voltage scaling parameter of 100%.

This parameter can be accessed if **[AI1 Type] R , I E** is set to **[Voltage] I D u**.

Setting	Description
0.0...10.0 Vdc	Setting range <b>Factory setting:</b> 10.0 Vdc

**[AI1 min. value] C r L I ★**

AI1 current scaling parameter of 0%.

This parameter can be accessed if **[AI1 Type] R , I E** is set to **[Current] D R**.

Setting	Description
0.0...20.0 mA	Setting range <b>Factory setting:</b> 0.0 mA

**[AI1 max. value] C r H I ★**

AI1 current scaling parameter of 100%.

This parameter can be accessed if **[AI1 Type] R , I E** is set to **[Current] D R**.

Setting	Description
0.0...20.0 mA	Setting range <b>Factory setting:</b> 20.0 mA

**[A11 Lowest Process] R , I J**

A11 lowest process.

Setting	Description
-32,767...32,767	Setting range. Value in application customer unit. <b>Factory setting:</b> 0

**[A11 Highest Process] R , I K**

A11 highest process.

Setting	Description
-32,767...32,767	Setting range. Value in application customer unit. <b>Factory setting:</b> 0

**[AI2 sensor config.] ▢ C R 2 - Menu**

**Access**

[Complete settings] → [Sensors assignment] → [AI2 sensor config.]

**[AI2 Type] R , 2 E**

Configuration of analog input AI2.

Setting	Code / Value	Description
[Voltage]	1 0 u	0-10 Vdc <b>Factory setting</b>
[Current]	0 R	0-20 mA
[PTC Management]	P E C	1 to 6 PTC (in serial)
[KTY]	K E Y	1 KTY84
[PT1000]	1 P E 3	1 PT1000 connected with 2 wires
[PT100]	1 P E 2	1 PT100 connected with 2 wires
[Water Prob]	L E u E L	Water level
[3PT1000]	3 P E 3	3 PT1000 connected with 2 wires
[3PT100]	3 P E 2	3 PT100 connected with 2 wires

**[AI2 min value] u , L 2 ★**

AI2 voltage scaling parameter of 0%.

This parameter can be accessed if [AI2 Type] R , 2 E is set to [Voltage] 1 0 u.

Identical to [AI1 min value] u , L 1 (see page 214).

**[AI2 max value] u , H 2 ★**

AI2 voltage scaling parameter of 100%.

This parameter can be accessed if [AI2 Type] R , 2 E is set to [Voltage] 1 0 u.

Identical to [AI1 max value] u , H 1 (see page 214).

**[AI2 min. value] C r L 2 ★**

AI2 current scaling parameter of 0%.

This parameter can be accessed if [AI2 Type] R , 2 E is set to [Current] 0 R.

Identical to [AI1 min. value] C r L 1 (see page 214).

**[AI2 max. value] C r H 2 ★**

AI2 current scaling parameter of 100%.

This parameter can be accessed if [AI2 Type] R , 2 E is set to [Current] 0 R.

Identical to [AI1 max. value] C r H 1 (see page 214).

**[AI2 Lowest Process] R , 2 J**

AI2 lowest process.

Identical to [AI1 Lowest Process] R , 1 J (see page 206).

**[AI2 Highest Process] R , 2 K**

AI2 highest process.

Identical to [AI1 Highest Process] R , 1 K (see page 206).



**[AI3 sensor config.] ▢ C R 3 - Menu****Access**

**[Complete settings] → [Sensors assignment] → [AI3 sensor config.]**

**[AI3 Type] R , 3 E**

Configuration of analog input AI3.

Identical to **[AI2 Type] R , 2 E** with factory setting: **[Current] ▢ R** (see page 216).

**[AI3 min value] ▢ , L 3 ★**

AI3 voltage scaling parameter of 0%.

This parameter can be accessed if **[AI2 Type] R , 2 E** is set to **[Voltage] I ▢ ▢**.

Identical to **[AI1 min value] ▢ , L 1** (see page 214).

**[AI3 max value] ▢ , H 3 ★**

AI3 voltage scaling parameter of 100%.

This parameter can be accessed if **[AI3 Type] R , 3 E** is set to **[Voltage] I ▢ ▢**.

Identical to **[AI1 max value] ▢ , H 1** (see page 214).

**[AI3 min. value] C r L 3 ★**

AI3 current scaling parameter of 0%.

This parameter can be accessed if **[AI3 Type] R , 3 E** is set to **[Current] ▢ R**.

Identical to **[AI1 min. value] C r L 1** (see page 214).

**[AI3 max. value] C r H 3 ★**

AI3 current scaling parameter of 100%.

This parameter can be accessed if **[AI3 Type] R , 3 E** is set to **[Current] ▢ R**.

Identical to **[AI1 max. value] C r H 1** (see page 214).

**[AI3 Lowest Process] R , 3 J**

AI3 lowest process.

Identical to **[AI1 Lowest Process] R , 1 J** (see page 206).

**[AI3 Highest Process] R , 3 K**

AI3 highest process.

Identical to **[AI1 Highest Process] R , 1 K** (see page 206).

**[AI4 sensor config.] ▢ C R 4 - Menu**

**Access**

[Complete settings] → [Sensors assignment] → [AI4 sensor config.]

**[AI4 Type] R , 4 E ★**

Configuration of analog input AI4.

This parameter can be accessed if VW3A3203 I/O extension module has been inserted.

Setting	Code / Value	Description
[Voltage]	I D u	0-10 Vdc
[Current]	D R	0-20 mA
[Voltage +/-]	n I D u	-10/+10 Vdc <b>Factory setting</b>
[PTC Management]	P E C	1 to 6 PTC (in serial)
[KTY]	K E Y	1 KTY84
[PT1000]	I P E 3	1 PT1000 connected with 2 wires
[PT100]	I P E 2	1 PT100 connected with 2 wires
[3 PT1000]	3 P E 3	3 PT1000 connected with 2 wires
[3 PT100]	3 P E 2	3 PT100 connected with 2 wires
[PT1000 in 3 wires]	I P E 3 3	1 PT1000 connected with 3 wires (AI4 & AI5 only)
[PT100 in 3 wires]	I P E 2 3	1 PT100 connected with 3 wires (AI4 & AI5 only)
[3 PT1000 in 3 wires]	3 P E 3 3	3 PT1000 connected with 3 wires (AI4 & AI5 only)
[3 PT100 in 3 wires]	3 P E 2 3	3 PT100 connected with 3 wires (AI4 & AI5 only)

**[AI4 min value] u , L 4 ★**

AI4 voltage scaling parameter of 0%.

Identical to [AI1 min value] u , L 1 (see page 214).

**[AI4 max value] u , H 4 ★**

AI4 voltage scaling parameter of 100%.

Identical to [AI1 max value] u , H 1 (see page 214).

**[AI4 min. value] C r L 4 ★**

AI4 current scaling parameter of 0%.

Identical to [AI1 min. value] C r L 1 (see page 214).

**[AI4 max. value] C r H 4 ★**

AI4 current scaling parameter of 100%.

Identical to [AI1 max. value] C r H 1 (see page 214).

**[AI4 Lowest Process] R , 4 J**

AI4 lowest process.

Identical to [AI1 Lowest Process] R , 1 J (see page 206).

**[AI4 Highest Process] R , 4 K**

AI4 highest process.

Identical to [AI1 Highest Process] R , 1 K (see page 206).

**[AI5 sensor config.]** ▢ **C R 5 - Menu****Access**

**[Complete settings] → [Sensors assignment] → [AI5 sensor config.]**

**[AI5 Type] R , 5 L ★**

Configuration of analog input AI5.

This parameter can be accessed if VW3A3203 I/O extension module has been inserted.

Identical to **[AI4 Type] R , 4 L** (see page 209).

**[AI5 min value] U , L 5 ★**

AI5 voltage scaling parameter of 0%.

Identical to **[AI1 min value] U , L 1** (see page 214).

**[AI5 max value] U , H 5 ★**

AI5 voltage scaling parameter of 100%.

Identical to **[AI1 max value] U , H 1** (see page 214).

**[AI5 min. value] C r L 5 ★**

AI5 current scaling parameter of 0%.

Identical to **[AI1 min. value] C r L 1** (see page 214).

**[AI5 max. value] C r H 5 ★**

AI5 current scaling parameter of 100%.

Identical to **[AI1 max. value] C r H 1** (see page 214).

**[AI5 Lowest Process] R , 5 J**

AI5 lowest process.

Identical to **[AI1 Lowest Process] R , 1 J** (see page 206).

**[AI5 Highest Process] R , 5 K**

AI5 highest process.

Identical to **[AI1 Highest Process] R , 1 K** (see page 206).

**[AIV1 sensor config.]** ▢ [ ] / - **Menu**

**Access**

[Complete settings] → [Sensors assignment] → [AIV1 sensor config.]

**[AIV1 Channel Assignment]** # , [ ]

Channel assignment for virtual analog input AIV1.

Setting	Code / Value	Description
[Not Configured]	<i>n a</i>	Not assigned <b>Factory setting</b>
[Ref. Freq-Modbus]	<i>Π d b</i>	Reference frequency via Modbus
[Ref. Freq-CANopen]	<i>ϵ R n</i>	Reference frequency via CANopen if a CANopen module has been inserted
[Ref. Freq-Com. Module]	<i>n E t</i>	Reference frequency via fieldbus module if a fieldbus module has been inserted
[Embedded Ethernet]	<i>E t H</i>	Embedded Ethernet

**[AIV1 Lowest Process]** # [ ] / J

AI virtual x: minimum process value.

Setting	Description
-32,767...32,767	Setting range <b>Factory setting: 0</b>

**[AIV1 Highest Process]** # [ ] / K

AI virtual x: maximum process value.

Setting	Description
-32,767...32,767	Setting range <b>Factory setting: 0</b>

**[Sensors assignment] 5 C C - Menu****Access**

[Complete settings] → [Sensors assignment]

**[Inst. Flow Assign.] F 5 I A ★**

Installation flow sensor assignment.

Setting	Code / Value	Description
[Not Configured]	n a	Not assigned <b>Factory setting</b>
[AI1]...[AI3]	R , 1...R , 3	Analog input AI1...AI3
[AI4]...[AI5]	R , 4...R , 5	Analog input AI4...AI5 if VW3A3203 I/O extension module has been inserted
[AI Virtual 1]	R , V 1	Virtual analogic input 1
[PulseInput Assignment On DI5]...[PulseInput Assignment On DI6]	P , 5...P , 6	Digital input DI5...DI6 used as pulse input
[Flow Estimation]	S L P F	Sensor less estimated flow

**[AI1 sensor config.] , F / - Menu****Access**

[Complete settings] → [Sensors assignment] → [AI1 sensor config.]

**[AI1 Type] R , I E**

Configuration of analog input AI1.

Setting	Code / Value	Description
[Voltage]	I 0 u	0-10 Vdc <b>Factory setting</b>
[Current]	0 R	0-20 mA

**[AI1 min value] u , L / ★**

AI1 voltage scaling parameter of 0%.

This parameter can be accessed if [AI1 Type] R , I E is to [Voltage] I 0 u.

Setting	Description
0.0...10.0 Vdc	Setting range <b>Factory setting:</b> 0.0 Vdc

**[AI1 max value] u , H / ★**

AI1 voltage scaling parameter of 100%.

This parameter can be accessed if [AI1 Type] R , I E is set to [Voltage] I 0 u.

Setting	Description
0.0...10.0 Vdc	Setting range <b>Factory setting:</b> 10.0 Vdc

**[AI1 min. value] C r L / ★**

AI1 current scaling parameter of 0%.

This parameter can be accessed if [AI1 Type] R , I E is set to [Current] 0 R.

Setting	Description
0.0...20.0 mA	Setting range <b>Factory setting:</b> 0.0 mA

**[AI1 max. value] C r H / ★**

AI1 current scaling parameter of 100%.

This parameter can be accessed if [AI1 Type] R , I E is set to [Current] 0 R.

Setting	Description
0.0...20.0 mA	Setting range <b>Factory setting:</b> 20.0 mA

**[A11 Lowest Process] R , I J**

A11 lowest process.

Setting	Description
-32,767...32,767	Setting range. Value in application customer unit. <b>Factory setting:</b> 0

**[A11 Highest Process] R , I K**

A11 highest process.

Setting	Description
-32,768...32,767	Setting range. Value in application customer unit. <b>Factory setting:</b> 0

**[AI2 sensor config.] , F 2 - Menu**

**Access**

[Complete settings] → [Sensors assignment] → [AI2 sensor config.]

**[AI2 Type] # , 2 E**

Configuration of analog input AI2.

Setting	Code / Value	Description
[Voltage]	1 0 u	0-10 Vdc <b>Factory setting</b>
[Current]	0 #	0-20 mA
[PTC Management]	P E C	1 to 6 PTC (in serial)
[KTY]	K E Y	1 KTY84
[PT1000]	1 P E 3	1 PT1000 connected with 2 wires
[PT100]	1 P E 2	1 PT100 connected with 2 wires
[Water Prob]	L E u E L	Water level
[3PT1000]	3 P E 3	3 PT1000 connected with 2 wires
[3PT100]	3 P E 2	3 PT100 connected with 2 wires

**[AI2 min value] u , L 2 ★**

AI2 voltage scaling parameter of 0%.

This parameter can be accessed if [AI2 Type] # , 2 E is set to [Voltage] 1 0 u.

Identical to [AI1 min value] u , L 1 (see page 222).

**[AI2 max value] u , H 2 ★**

AI2 voltage scaling parameter of 100%.

This parameter can be accessed if [AI2 Type] # , 2 E is set to [Voltage] 1 0 u.

Identical to [AI1 max value] u , H 1 (see page 222).

**[AI2 min. value] C r L 2 ★**

AI2 current scaling parameter of 0%.

This parameter can be accessed if [AI2 Type] # , 2 E is set to [Current] 0 #.

Identical to [AI1 min. value] C r L 1 (see page 222).

**[AI2 max. value] C r H 2 ★**

AI2 current scaling parameter of 100%.

This parameter can be accessed if [AI2 Type] # , 2 E is set to [Current] 0 #.

Identical to [AI1 max. value] C r H 1 (see page 222).

**[AI2 Lowest Process] # , 2 J**

AI2 lowest process.

Identical to [AI1 Lowest Process] # , 1 J (see page 223).

**[AI2 Highest Process] # , 2 K**

AI2 highest process.

Identical to [AI1 Highest Process] # , 1 K (see page 223).



**[AI3 sensor config.] , F 3 - Menu****Access**

**[Complete settings] → [Sensors assignment] → [AI3 sensor config.]**

**[AI3 Type] R , 3 E**

Configuration of analog input AI3.

Identical to **[AI2 Type] R , 2 E** with factory setting: **[Current] 0 R** (see page 224).

**[AI3 min value] U , L 3 ★**

AI3 voltage scaling parameter of 0%.

This parameter can be accessed if **[AI3 Type] R , 3 E** is set to **[Voltage] 1 0 U**.

Identical to **[AI1 min value] U , L 1** (see page 222).

**[AI3 max value] U , H 3 ★**

AI3 voltage scaling parameter of 100%.

This parameter can be accessed if **[AI3 Type] R , 3 E** is set to **[Voltage] 1 0 U**.

Identical to **[AI1 max value] U , H 1** (see page 222).

**[AI3 min. value] C r L 3 ★**

AI3 current scaling parameter of 0%.

This parameter can be accessed if **[AI3 Type] R , 3 E** is set to **[Current] 0 R**.

Identical to **[AI1 min. value] C r L 1** (see page 222).

**[AI3 max. value] C r H 3 ★**

AI3 current scaling parameter of 100%.

This parameter can be accessed if **[AI3 Type] R , 3 E** is set to **[Current] 0 R**.

Identical to **[AI1 max. value] C r H 1** (see page 222).

**[AI3 Lowest Process] R , 3 J**

AI3 lowest process.

Identical to **[AI1 Lowest Process] R , 1 J** (see page 223).

**[AI3 Highest Process] R , 3 K**

AI3 highest process.

Identical to **[AI1 Highest Process] R , 1 K** (see page 223).

**[AI4 sensor config.] , F 4 - Menu****Access**

[Complete settings] → [Sensors assignment] → [AI4 sensor config.]

**[AI4 Type] # , 4 E ★**

Configuration of analog input AI4.

This parameter can be accessed if VW3A3203 I/O extension module has been inserted.

Setting	Code / Value	Description
[Voltage]	I 0 u	0-10 Vdc
[Current]	0 A	0-20 mA
[Voltage +/-]	n I 0 u	-10/+10 Vdc <b>Factory setting</b>
[PTC Management]	P E C	1 to 6 PTC (in serial)
[KTY]	K E Y	1 KTY84
[PT1000]	I P E 3	1 PT1000 connected with 2 wires
[PT100]	I P E 2	1 PT100 connected with 2 wires
[3 PT1000]	3 P E 3	3 PT1000 connected with 2 wires
[3 PT100]	3 P E 2	3 PT100 connected with 2 wires
[PT1000 in 3 wires]	I P E 3 3	1 PT1000 connected with 3 wires (AI4 & AI5 only)
[PT100 in 3 wires]	I P E 2 3	1 PT100 connected with 3 wires (AI4 & AI5 only)
[3 PT1000 in 3 wires]	3 P E 3 3	3 PT1000 connected with 3 wires (AI4 & AI5 only)
[3 PT100 in 3 wires]	3 P E 2 3	3 PT100 connected with 3 wires (AI4 & AI5 only)

**[AI4 min value] u , L 4 ★**

AI4 voltage scaling parameter of 0%.

Identical to [AI1 min value] u , L 1 (see page 222).

**[AI4 max value] u , H 4 ★**

AI4 voltage scaling parameter of 100%.

Identical to [AI1 max value] u , H 1 (see page 222).

**[AI4 min. value] C r L 4 ★**

AI4 current scaling parameter of 0%.

Identical to [AI1 min. value] C r L 1 (see page 222).

**[AI4 max. value] C r H 4 ★**

AI4 current scaling parameter of 100%.

Identical to [AI1 max. value] C r H 1 (see page 222).

**[AI4 Lowest Process] # , 4 J**

AI4 lowest process.

Identical to [AI1 Lowest Process] # , I J (see page 223).

**[AI4 Highest Process] # , 4 K**

AI4 highest process.

Identical to [AI1 Highest Process] # , I K (see page 223).

**[AI5 sensor config.] , F 5 - Menu****Access**

**[Complete settings] → [Sensors assignment] → [AI5 sensor config.]**

**[AI5 Type] # , 5 L ★**

Configuration of analog input AI5.

This parameter can be accessed if VW3A3203 I/O extension module has been inserted.

Identical to **[AI4 Type] # , 4 L** (see page 226).

**[AI5 min value] ∪ , L 5 ★**

AI5 voltage scaling parameter of 0%.

Identical to **[AI1 min value] ∪ , L 1** (see page 222).

**[AI5 max value] ∪ , H 5 ★**

AI5 voltage scaling parameter of 100%.

Identical to **[AI1 max value] ∪ , H 1** (see page 222).

**[AI5 min. value] C r L 5 ★**

AI5 current scaling parameter of 0%.

Identical to **[AI1 min. value] C r L 1** (see page 222).

**[AI5 max. value] C r H 5 ★**

AI5 current scaling parameter of 100%.

Identical to **[AI1 max. value] C r H 1** (see page 222).

**[AI5 Lowest Process] # , 5 J**

AI5 lowest process.

Identical to **[AI1 Lowest Process] # , 1 J** (see page 223).

**[AI5 Highest Process] # , 5 K**

AI5 highest process.

Identical to **[AI1 Highest Process] # , 1 K** (see page 223).

**[DI5 Pulse Sensor Config.] , F B - Menu****Access**

[Complete settings] → [Sensors assignment] → [Inst. Flow Assign] → [ PulseInput Assignment]  
→ [DI5 Pulse Sensor Config.]

**About This Menu**

Following parameters can be accessed if [Inst. Flow Assign.] F 5 I A is set to [DI5 PulseInput Assignment] P , 5.

**[DI5 PulseInput Low Freq] P , L 5**

Pulse input DI5 low frequency.

Setting	Description
0.00...30,000.00 Hz	Setting range <b>Factory setting:</b> 0.00 Hz

**[DI5 PulseInput High Freq] P , H 5**

Pulse input DI5 high frequency.

Setting	Description
0.00...30.00 kHz	Setting range <b>Factory setting:</b> 30.00 kHz

**[DI5 Min Process] P , 5 J**

Minimum process value for selected input.

Setting	Description
-32,767...32,767	Setting range <b>Factory setting:</b> 0

**[DI5 Max Process] P , 5 K**

Maximum process value for selected input.

Setting	Description
-32,767...32,767	Setting range <b>Factory setting:</b> 0

## [DI6 Pulse Sensor Config.] , F 9 - Menu

### Access

[Complete settings] → [Sensors assignment] → [DI6 Pulse Sensor Config.]

### About This Menu

Following parameters can be accessed if [Inst. Flow Assign.] F 5 / H is set to [DI6 PulseInput Assignment] P , 6 .

Identical to [DI5 Pulse Sensor Config.] , F 8 - Menu ([see page 337](#)).

### [DI6 PulseInput Low Freq] P , L 6

Pulse input DI6 low frequency.

### [DI6 PulseInput High Freq] P , H 6

Pulse input DI6 high frequency.

### [DI6 Min Process] P , 6 J

Minimum process value for selected input.

### [DI6 Max Process] P , 6 K

Maximum process value for selected input.

## [AIV1 sensor config.] , F V I - Menu

### Access

[Complete settings] → [Sensors assignment] → [AIV1 sensor config.]

### [AIV1 Channel Assignment] A , C I

Channel assignment for virtual analog input AIV1.

Setting	Code / Value	Description
[Not Configured]	n o	Not assigned <b>Factory setting</b>
[Ref. Freq-Modbus]	Π d b	Reference frequency via Modbus
[Ref. Freq-CANopen]	C A n	Reference frequency via CANopen if a CANopen module has been inserted
[Ref. Freq-Com. Module]	n E t	Reference frequency via fieldbus module if a fieldbus module has been inserted
[Embedded Ethernet]	E t H	Embedded Ethernet

### [AIV1 Lowest Process] A u I J

AI virtual x: minimum process value.

This parameter is also available when selecting [Ref. Freq-Modbus] Π d b and [Embedded Ethernet] E t H.

Setting	Description
-32,767...32,767	Setting range <b>Factory setting:</b> 0

### [AIV1 Highest Process] A u I K

AI virtual x: maximum process value.

This parameter is also available when selecting [Ref. Freq-Modbus] Π d b and [Embedded Ethernet] E t H.

Setting	Description
-32,767...32,767	Setting range <b>Factory setting:</b> 0

**[Sensors assignment] 5 L C - Menu****Access**

[Complete settings] → [Sensors assignment]

**[Pump Flow Assign.] F 5 2 A ★**

Pump flow sensor assignment.

Setting	Code / Value	Description
[Not Configured]	<i>n o</i>	Not assigned <b>Factory setting</b>
[AI1]...[AI3]	<i>A , 1...A , 3</i>	Analog input AI1...AI3
[AI4]...[AI5]	<i>A , 4...A , 5</i>	Analog input AI4...AI5 if VW3A3203 I/O extension module has been inserted
[AI Virtual 1]	<i>A , V 1</i>	Virtual analogic input 1
[PulseInput Assignment On DI5]...[PulseInput Assignment On DI6]	<i>P , 5...P , 6</i>	Digital input DI5...DI6 used as pulse input
[Flow Estimation]	<i>S L P F</i>	Sensor less estimated flow

## [AI1 sensor config.] PF I - Menu

### Access

[Complete settings] → [Sensors assignment] → [AI1 sensor config.]

### About This Menu

This menu can be accessed if:

- [Pump Flow Assign.] FSZP is set to [AI1] R I, and
- [Pump System Architecture] PPSA is not set to [No] n o.

### [AI1 Type] R I E

Configuration of analog input AI1.

Setting	Code / Value	Description
[Voltage]	10 V	0-10 Vdc <b>Factory setting</b>
[Current]	20 mA	0-20 mA

### [AI1 min value] V L I ★

AI1 voltage scaling parameter of 0%.

This parameter can be accessed if [AI1 Type] R I E is to [Voltage] 10 V.

Setting	Description
0.0...10.0 Vdc	Setting range <b>Factory setting:</b> 0.0 Vdc

### [AI1 max value] V H I ★

AI1 voltage scaling parameter of 100%.

This parameter can be accessed if [AI1 Type] R I E is set to [Voltage] 10 V.

Setting	Description
0.0...10.0 Vdc	Setting range <b>Factory setting:</b> 10.0 Vdc

### [AI1 min. value] C L I ★

AI1 current scaling parameter of 0%.

This parameter can be accessed if [AI1 Type] R I E is set to [Current] 20 mA.

Setting	Description
0.0...20.0 mA	Setting range <b>Factory setting:</b> 0.0 mA

### [AI1 max. value] C H I ★

AI1 current scaling parameter of 100%.

This parameter can be accessed if [AI1 Type] R I E is set to [Current] 20 mA.

Setting	Description
0.0...20.0 mA	Setting range <b>Factory setting:</b> 20.0 mA



**[A11 Lowest Process] R , I J**

A11 lowest process.

Setting	Description
-32,767...32,767	Setting range. Value in application customer unit. <b>Factory setting:</b> 0

**[A11 Highest Process] R , I K**

A11 highest process.

Setting	Description
-32,767...32,767	Setting range. Value in application customer unit. <b>Factory setting:</b> 0

## [AI2 sensor config.] P F 2 - Menu

### Access

[Complete settings] → [Sensors assignment] → [AI2 sensor config.]

### About This Menu

This menu can be accessed if:

- [Pump Flow Assign.] F 5 2 A is set to [AI2] A , 2 , and
- [Pump System Architecture] П P 5 A is not set to [No] n o .

### [AI2 Type] A , 2 E

Configuration of analog input AI2.

Setting	Code / Value	Description
[Voltage]	1 0 u	0-10 Vdc <b>Factory setting</b>
[Current]	o A	0-20 mA
[PTC Management]	P E C	1 to 6 PTC (in serial)
[KTY]	K E Y	1 KTY84
[PT1000]	1 P E 3	1 PT1000 connected with 2 wires
[PT100]	1 P E 2	1 PT100 connected with 2 wires
[Water Prob]	L E u E L	Water level
[3PT1000]	3 P E 3	3 PT1000 connected with 2 wires
[3PT100]	3 P E 2	3 PT100 connected with 2 wires

### [AI2 min value] u , L 2 ★

AI2 voltage scaling parameter of 0%.

This parameter can be accessed if [AI2 Type] A , 2 E is set to [Voltage] 1 0 u .

Identical to [AI1 min value] u , L 1 (see page 232).

### [AI2 max value] u , H 2 ★

AI2 voltage scaling parameter of 100%.

This parameter can be accessed if [AI2 Type] A , 2 E is set to [Voltage] 1 0 u .

Identical to [AI1 max value] u , H 1 (see page 232).

### [AI2 min. value] C r L 2 ★

AI2 current scaling parameter of 0%.

This parameter can be accessed if [AI2 Type] A , 2 E is set to [Current] o A .

Identical to [AI1 min. value] C r L 1 (see page 232).

### [AI2 max. value] C r H 2 ★

AI2 current scaling parameter of 100%.

This parameter can be accessed if [AI2 Type] A , 2 E is set to [Current] o A .

Identical to [AI1 max. value] C r H 1 (see page 232).

**[AI2 Lowest Process] R , 2 J**

AI2 lowest process.

Identical to **[AI1 Lowest Process] R , 1 J** (*see page 233*).

**[AI2 Highest Process] R , 2 K**

AI2 highest process.

Identical to **[AI1 Highest Process] R , 1 K** (*see page 233*).

## [AI3 sensor config.] P F 3 - Menu

### Access

[Complete settings] → [Sensors assignment] → [AI3 sensor config.]

### About This Menu

This menu can be accessed if:

- [Pump Flow Assign.] F 5 2 A is set to [AI3] A , 3 , and
- [Pump System Architecture] П P 5 A is not set to [No] n o .

### [AI3 Type] A , 3 E

Configuration of analog input AI3.

Identical to [AI2 Type] A , 2 E with factory setting: [Current] D A (see page 234).

### [AI3 min value] u , L 3 ★

AI3 voltage scaling parameter of 0%.

This parameter can be accessed if [AI3 Type] A , 3 E is set to [Voltage] I D u .

Identical to [AI1 min value] u , L 1 (see page 232).

### [AI3 max value] u , H 3 ★

AI3 voltage scaling parameter of 100%.

This parameter can be accessed if [AI3 Type] A , 3 E is set to [Voltage] I D u .

Identical to [AI1 max value] u , H 1 (see page 232).

### [AI3 min. value] C r L 3 ★

AI3 current scaling parameter of 0%.

This parameter can be accessed if [AI3 Type] A , 3 E is set to [Current] o A .

Identical to [AI1 min. value] C r L 1 (see page 232).

### [AI3 max. value] C r H 3 ★

AI3 current scaling parameter of 100%.

This parameter can be accessed if [AI3 Type] A , 3 E is set to [Current] o A .

Identical to [AI1 max. value] C r H 1 (see page 232).

### [AI3 Lowest Process] A , 3 J

AI3 lowest process.

Identical to [AI1 Lowest Process] A , 1 J (see page 233).

### [AI3 Highest Process] A , 3 K

AI3 highest process.

Identical to [AI1 Highest Process] A , 1 K (see page 233).

## [AI4 sensor config.] P F 4 - Menu

### Access

[Complete settings] → [Sensors assignment] → [AI4 sensor config.]

### About This Menu

This menu can be accessed if:

- [Pump Flow Assign.] F 5 2 A is set to [AI4] A , 4, and
- [Pump System Architecture] P P 5 A is not set to [No] n o.

### [AI4 Type] A , 4 E ★

Configuration of analog input AI4.

This parameter can be accessed if VW3A3203 I/O extension module has been inserted.

Setting	Code / Value	Description
[Voltage]	I O u	0-10 Vdc
[Current]	O R	0-20 mA
[Voltage +/-]	n I O u	-10/+10 Vdc <b>Factory setting</b>
[PTC Management]	P E C	1 to 6 PTC (in serial)
[KTY]	K E Y	1 KTY84
[PT1000]	I P E 3	1 PT1000 connected with 2 wires
[PT100]	I P E 2	1 PT100 connected with 2 wires
[3 PT1000]	3 P E 3	3 PT1000 connected with 2 wires
[3 PT100]	3 P E 2	3 PT100 connected with 2 wires
[PT1000 in 3 wires]	I P E 3 3	1 PT1000 connected with 3 wires (AI4 & AI5 only)
[PT100 in 3 wires]	I P E 2 3	1 PT100 connected with 3 wires (AI4 & AI5 only)
[3 PT1000 in 3 wires]	3 P E 3 3	3 PT1000 connected with 3 wires (AI4 & AI5 only)
[3 PT100 in 3 wires]	3 P E 2 3	3 PT100 connected with 3 wires (AI4 & AI5 only)

### [AI4 min value] u , L 4 ★

AI4 voltage scaling parameter of 0%.

Identical to [AI1 min value] u , L 1 (see page 232).

### [AI4 max value] u , H 4 ★

AI4 voltage scaling parameter of 100%.

Identical to [AI1 max value] u , H 1 (see page 232).

### [AI4 min. value] C r L 4 ★

AI4 current scaling parameter of 0%.

Identical to [AI1 min. value] C r L 1 (see page 232).

### [AI4 max. value] C r H 4 ★

AI4 current scaling parameter of 100%.

Identical to [AI1 max. value] C r H 1 (see page 232).

**[AI4 Lowest Process] R , 4 J**

A14 lowest process.

Identical to **[AI1 Lowest Process] R , 1 J** (*see page 233*).

**[AI4 Highest Process] R , 4 K**

A14 highest process.

Identical to **[AI1 Highest Process] R , 1 K** (*see page 233*).

## [AI5 sensor config.] P F 5 - Menu

### Access

[Complete settings] → [Sensors assignment] → [AI5 sensor config.]

### About This Menu

This menu can be accessed if:

- [Pump Flow Assign.] F 5 2 A is set to [AI5] A , 5 , and
- [Pump System Architecture] P P 5 A is not set to [No] n o .

### [AI5 Type] A , 5 E ★

Configuration of analog input AI5.

This parameter can be accessed if VW3A3203 I/O extension module has been inserted.

Identical to [AI4 Type] A , 4 E (see page 237).

### [AI5 min value] u , L 5 ★

AI5 voltage scaling parameter of 0%.

Identical to [AI1 min value] u , L 1 (see page 232).

### [AI5 max value] u , H 5 ★

AI5 voltage scaling parameter of 100%.

Identical to [AI1 max value] u , H 1 (see page 232).

### [AI5 min. value] C r L 5 ★

AI5 current scaling parameter of 0%.

Identical to [AI1 min. value] C r L 1 (see page 232).

### [AI5 max. value] C r H 5 ★

AI5 current scaling parameter of 100%.

Identical to [AI1 max. value] C r H 1 (see page 232).

### [AI5 Lowest Process] A , 5 J

AI5 lowest process.

Identical to [AI1 Lowest Process] A , 1 J (see page 233).

### [AI5 Highest Process] A , 5 K

AI5 highest process.

Identical to [AI1 Highest Process] A , 1 K (see page 233).

## [DI5 configuration] PFB - Menu

### Access

[Complete settings] → [Sensors assignment] → [Inst. Flow Assign] → [PulseInput Assignment] → [DI5 configuration]

### About This Menu

This menu can be accessed if:

- [Pump Flow Assign.] FS2A is set to [di5 PulseInput Assignment] d15, and
- [Pump System Architecture] PPSA is not set to [No] na.

### [PulseInput DI5 Low Freq] P,LS

Pulse input DI5 low frequency.

Setting	Description
0.00...30,000.00 Hz	Setting range Factory setting: 0.00 Hz

### [PulseInput DI5 High Freq] P,HS

Pulse input DI5 high frequency.

Setting	Description
0.00...30.00 kHz	Setting range Factory setting: 30.00 kHz

### [DI5 Min Process] P,5J

Minimum process value for selected input.

Setting	Description
-32,767...32,767	Setting range Factory setting: 0

### [DI5 Max Process] P,5K

Maximum process value for selected input.

Setting	Description
-32,767...32,767	Setting range Factory setting: 0



## [DI6 configuration] P F 9 - Menu

### Access

[Complete settings] → [Sensors assignment] → [DI6 configuration]

### About This Menu

This menu can be accessed if:

- [Pump Flow Assign.] F 5 2 A is set to [di6 PulseInput Assignment] d , 6 , and
- [Pump System Architecture] П P 5 A is not set to [No] n o .

Identical to [DI5 configuration] P F 8 - Menu (*see page 240*).

### [PulseInput DI6 Low Freq] P , L 6

Pulse input DI6 low frequency.

### [PulseInput DI6 High Freq] P , H 6

Pulse input DI6 high frequency.

### [DI6 Min Process] P , 6 J

Minimum process value for selected input.

### [DI6 Max Process] P , 6 K

Maximum process value for selected input.

**[AIV1 configuration] P F V I - Menu****Access**

[Complete settings] → [Sensors assignment] → [AIV1 configuration]

**About This Menu**

This menu can be accessed if:

- [Pump Flow Assign.] F S Z A is set to [AI Virtual 1] A I V I, and
- [Pump System Architecture] P P S A is not set to [No] n o.

**[AIV1 Channel Assignment] A , C I**

Channel assignment for virtual analog input AIV1.

Setting	Code / Value	Description
[Not Configured]	n o	Not assigned <b>Factory setting</b>
[Ref. Freq-Modbus]	M d b	Reference frequency via Modbus
[Ref. Freq-CANopen]	C A n	Reference frequency via CANopen if a CANopen module has been inserted
[Ref. Freq-Com. Module]	n E t	Reference frequency via fieldbus module if a fieldbus module has been inserted
[Embedded Ethernet]	E t H	Embedded Ethernet

**[AIV1 Lowest Process] A U I J**

AI virtual x: minimum process value.

This parameter is also available when selecting [Ref. Freq-Modbus] M d b and [Embedded Ethernet] E t H.

Setting	Description
-32,767...32,767	Setting range. Value in application customer unit <b>Factory setting: 0</b>

**[AIV1 Highest Process] A U I K**

AI virtual x: maximum process value.

This parameter is also available when selecting [Ref. Frequency via Modbus] M d b and [Embedded Ethernet] E t H.

Setting	Description
-32,767...32,767	Setting range. Value in application customer unit <b>Factory setting: 0</b>

**[Sensors assignment] 5 C C - Menu****Access**

[Complete settings] → [Sensors assignment]

**[Level Sensor Assign] L C 5 A ★**

Level sensor assignment.

This parameter can be accessed if [Application Selection] *R P P L* is set to [Level] *L E V E L*.

Setting	Code / Value	Description
[Not Configured]	<i>n o</i>	Not assigned <b>Factory setting</b>
[AI1]...[AI3]	<i>A , 1...A , 3</i>	Analog input AI1...AI3
[AI4]...[AI5]	<i>A , 4...A , 5</i>	Analog input AI4...AI5 if VW3A3203 I/O extension module has been inserted
[AI Virtual 1]	<i>A , V 1</i>	Virtual analogic input 1

**[AI1 configuration] L C R I - Menu****Access**

[Complete settings] → [Sensors assignment] → [AI1 configuration]

**About This Menu**

This menu can be accessed if [Level Sensor Assign] L C 5 R is set to [AI1] R , I .

**[AI1 Type] R , I E**

Configuration of analog input AI1.

Setting	Code / Value	Description
[Voltage]	I 0 u	0-10 Vdc <b>Factory setting</b>
[Current]	0 R	0-20 mA

**[AI1 min value] u , L I ★**

AI1 voltage scaling parameter of 0%.

This parameter can be accessed if [AI1 Type] R , I E is set to [Voltage] I 0 u .

Setting	Description
0.0...10.0 Vdc	Setting range <b>Factory setting:</b> 0.0 Vdc

**[AI1 max value] u , H I ★**

AI1 voltage scaling parameter of 100%.

This parameter can be accessed if [AI1 Type] R , I E is set to [Voltage] I 0 u .

Setting	Description
0.0...10.0 Vdc	Setting range <b>Factory setting:</b> 10.0 Vdc

**[AI1 min. value] C r L I ★**

AI1 current scaling parameter of 0%.

This parameter can be accessed if [AI1 Type] R , I E is set to [Current] 0 R .

Setting	Description
0.0...20.0 mA	Setting range <b>Factory setting:</b> 0.0 mA

**[AI1 max. value] C r H I ★**

AI1 current scaling parameter of 100%.

This parameter can be accessed if [AI1 Type] R , I E is set to [Current] 0 R .

Setting	Description
0.0...20.0 mA	Setting range <b>Factory setting:</b> 20.0 mA

**[A11 Lowest Process] R , I J**

A11 lowest process.

Setting	Description
-32,767...32,767	Setting range. Value in application customer unit. <b>Factory setting:</b> 0

**[A11 Highest Process] R , I K**

A11 highest process.

Setting	Description
-32,767...32,767	Setting range. Value in application customer unit. <b>Factory setting:</b> 0

## [AI2 configuration] L C R 2 - Menu

### Access

[Complete settings] → [Sensors assignment] → [AI2 configuration]

### About This Menu

This menu can be accessed if [Level Sensor Assign] L C 5 R is set to [AI2] R , 2 .

### [AI2 Type] R , 2 E

Configuration of analog input AI2.

Setting	Code / Value	Description
[Voltage]	1 0 u	0-10 Vdc <b>Factory setting</b>
[Current]	0 R	0-20 mA
[PTC Management]	P E C	1 to 6 PTC (in serial)
[KTY]	K E Y	1 KTY84
[PT1000]	1 P E 3	1 PT1000 connected with 2 wires
[PT100]	1 P E 2	1 PT100 connected with 2 wires
[Water Prob]	L E u E L	Water level
[3PT1000]	3 P E 3	3 PT1000 connected with 2 wires
[3PT100]	3 P E 2	3 PT100 connected with 2 wires

### [AI2 min value] u , L 2 ★

AI2 voltage scaling parameter of 0%.

This parameter can be accessed if [AI2 Type] R , 2 E is set to [Voltage] 1 0 u .

Identical to [AI1 min value] u , L 1 (see page 244).

### [AI2 max value] u , H 2 ★

AI2 voltage scaling parameter of 100%.

This parameter can be accessed if [AI2 Type] R , 2 E is set to [Voltage] 1 0 u .

Identical to [AI1 max value] u , H 1 (see page 244).

### [AI2 min. value] C r L 2 ★

AI2 current scaling parameter of 0%.

This parameter can be accessed if [AI2 Type] R , 2 E is set to [Current] 0 R .

Identical to [AI1 min. value] C r L 1 (see page 244).

### [AI2 max. value] C r H 2 ★

AI2 current scaling parameter of 100%.

This parameter can be accessed if [AI2 Type] R , 2 E is set to [Current] 0 R .

Identical to [AI1 max. value] C r H 1 (see page 244).

### [AI2 Lowest Process] R , 2 J

AI2 lowest process.

Identical to [AI1 Lowest Process] R , 1 J (see page 245).

### [AI2 Highest Process] R , 2 K

AI2 highest process.

Identical to [AI1 Highest Process] R , 1 K (see page 245).

## [AI3 configuration] L C R E - Menu

### Access

[Complete settings] → [Sensors assignment] → [AI3 configuration]

### About This Menu

This menu can be accessed if [Level Sensor Assign] L C 5 R is set to [AI3] R , E .

### [AI3 Type] R , E E

Configuration of analog input AI3.

Identical to [AI2 Type] R , E E with factory setting: [Current] R R .

### [AI3 min value] R , L E ★

AI3 voltage scaling parameter of 0%.

This parameter can be accessed if [AI2 Type] R , E E is set to [Voltage] I R R .

Identical to [AI1 min value] R , L I (see page 244).

### [AI3 max value] R , H E ★

AI3 voltage scaling parameter of 100%.

This parameter can be accessed if [AI3 Type] R , E E is set to [Voltage] I R R .

Identical to [AI1 max value] R , H I (see page 244).

### [AI3 min. value] C R L E ★

AI3 current scaling parameter of 0%.

This parameter can be accessed if [AI3 Type] R , E E is set to [Current] R R .

Identical to [AI1 min. value] C R L I (see page 244).

### [AI3 max. value] C R H E ★

AI3 current scaling parameter of 100%.

This parameter can be accessed if [AI3 Type] R , E E is set to [Current] R R .

Identical to [AI1 max. value] C R H I (see page 244).

### [AI3 Lowest Process] R , E J

AI3 lowest process.

Identical to [AI1 Lowest Process] R , I J (see page 245).

### [AI3 Highest Process] R , E K

AI3 highest process.

Identical to [AI1 Highest Process] R , I K (see page 245).

**[AI4 configuration] L C R 4 - Menu**

**Access**

[Complete settings] → [Sensors assignment] → [AI4 configuration]

**About This Menu**

This menu can be accessed if [Level Sensor Assign] L C 5 R is set to [AI5] R , 5 .

**[AI4 Type] R , 4 E ★**

Configuration of analog input AI4.

This parameter can be accessed if VW3A3203 I/O extension module has been inserted.

Setting	Code / Value	Description
[Voltage]	I D u	0-10 Vdc
[Current]	D R	0-20 mA
[Voltage +/-]	n I D u	-10/+10 Vdc <b>Factory setting</b>
[PTC Management]	P E C	1 to 6 PTC (in serial)
[KTY]	K E Y	1 KTY84
[PT1000]	I P E 3	1 PT1000 connected with 2 wires
[PT100]	I P E 2	1 PT100 connected with 2 wires
[3 PT1000]	3 P E 3	3 PT1000 connected with 2 wires
[3 PT100]	3 P E 2	3 PT100 connected with 2 wires
[PT1000 in 3 wires]	I P E 3 3	1 PT1000 connected with 3 wires (AI4 & AI5 only)
[PT100 in 3 wires]	I P E 2 3	1 PT100 connected with 3 wires (AI4 & AI5 only)
[3 PT1000 in 3 wires]	3 P E 3 3	3 PT1000 connected with 3 wires (AI4 & AI5 only)
[3 PT100 in 3 wires]	3 P E 2 3	3 PT100 connected with 3 wires (AI4 & AI5 only)

**[AI4 min value] u , L 4 ★**

AI4 voltage scaling parameter of 0%.

Identical to [AI1 min value] u , L 1 (see page 244).

**[AI4 max value] u , H 4 ★**

AI4 voltage scaling parameter of 100%.

Identical to [AI1 max value] u , H 1 (see page 244).

**[AI4 min. value] C r L 4 ★**

AI4 current scaling parameter of 0%.

Identical to [AI1 min. value] C r L 1 (see page 244).

**[AI4 max. value] C r H 4 ★**

AI4 current scaling parameter of 100%.

Identical to [AI1 max. value] C r H 1 (see page 244).

**[AI4 Lowest Process] R , 4 J**

AI4 lowest process.

Identical to [AI1 Lowest Process] R , 1 J (see page 245).

**[AI4 Highest Process] R , 4 K**

AI4 highest process.

Identical to [AI1 Highest Process] R , 1 K (see page 245).



## [AI5 configuration] L C R 5 - Menu

### Access

[Complete settings] → [Sensors assignment] → [AI5 configuration]

### About This Menu

This menu can be accessed if [Level Sensor Assign] L C 5 R is set to [AI5] R , 5.

### [AI5 Type] R , 5 E ★

Configuration of analog input AI5.

This parameter can be accessed if VW3A3203 I/O extension module has been inserted.

Identical to [AI4 Type] R , 4 E .

### [AI5 min value] U , L 5 ★

AI5 voltage scaling parameter of 0%.

Identical to [AI1 min value] U , L 1 (see page 244).

### [AI5 max value] U , H 5 ★

AI5 voltage scaling parameter of 100%.

Identical to [AI1 max value] U , H 1 (see page 244).

### [AI5 min. value] C r L 5 ★

AI5 current scaling parameter of 0%.

Identical to [AI1 min. value] C r L 1 (see page 289).

### [AI5 max. value] C r H 5 ★

AI5 current scaling parameter of 100%.

Identical to [AI1 max. value] C r H 1 (see page 244).

### [AI5 Lowest Process] R , 5 J

AI5 lowest process.

Identical to [AI1 Lowest Process] R , 1 J (see page 245).

### [AI5 Highest Process] R , 5 K

AI5 highest process.

Identical to [AI1 Highest Process] R , 1 K (see page 245).

## [AIV1 configuration] L C U I - Menu

### Access

[Complete settings] → [Sensors assignment] → [AIV1 configuration]

### About This Menu

This menu can be accessed if [Level Sensor Assign] L C 5 A is set to [AIV1] A , V I.

### [AIV1 Channel Assignment] A , C I

Channel assignment for virtual analog input AIV1.

Setting	Code / Value	Description
[Not Configured]	n a	Not assigned <b>Factory setting</b>
[Ref. Freq-Modbus]	Π d b	Reference frequency via Modbus
[Ref. Freq-CANopen]	C A n	Reference frequency via CANopen if a CANopen module has been inserted
[Ref. Freq-Com. Module]	n E t	Reference frequency via fieldbus module if a fieldbus module has been inserted
[Embedded Ethernet]	E t H	Embedded Ethernet

### [AIV1 Lowest Process] A U I J

AI virtual x: minimum process value.

Setting	Description
-32,767...32,767	Setting range. Value in application customer unit <b>Factory setting:</b> 0

### [AIV1 Highest Process] A U I K

AI virtual x: maximum process value.

Setting	Description
-32,767...32,767	Setting range. Value in application customer unit <b>Factory setting:</b> 0

## Section 7.6

### [Command and Reference]

#### [Command and Reference] $C_r P$ - Menu

##### Access

[Complete settings] → [Command and Reference]

##### Command and Reference Channels Parameter Can Be Accessed

Run commands (forward, reverse, stop, and so on) and references can be sent using the following channels:

Command	Reference
Terminals: Digital inputs DI	Terminals: Analog inputs AI, pulse input
Graphic Display Terminal	Graphic Display Terminal
Integrated Modbus	Integrated Modbus
CANopen®	CANopen
Fieldbus module	Fieldbus module
–	+/- speed via the Graphic Display Terminal
Integrated Ethernet Modbus TCP	Integrated Ethernet Modbus TCP

**NOTE:** The stop keys on the Graphic Display Terminal can be programmed as non-priority keys. A stop key can only have priority if the **[Stop Key Enable]  $P 5 E$**  parameter menu is set to **[Yes]  $Y E 5$** .

The behavior of the drive can be adapted according to requirements:

- **[Not separ.]  $S , P$** : Command and reference are sent via the same channel.
- **[Separate]  $S E P$** : Command and reference may be sent via different channels. In these configurations, control via the communication bus is performed in accordance with the DRIVECOM standard with only 5 freely assignable bits (see communication parameter manual). The application functions cannot be accessed via the communication interface.
- **[I/O profile]  $, P$** : The command and the reference can come from different channels. This configuration both simplifies and extends use via the communication interface. Commands may be sent via the digital inputs on the terminals or via the communication bus. When commands are sent via a bus, they are available on a word, which acts as virtual terminals containing only digital inputs. Application functions can be assigned to the bits in this word. More than one function can be assigned to the same bit.

**NOTE:** Stop commands from the Graphic Display Terminal remain active even if the terminals are not the active command channel.

Reference Channel for [Not separ.] S, Π, [Separate] SEP and [I/O profile] I, O Configurations, PID Not Configured

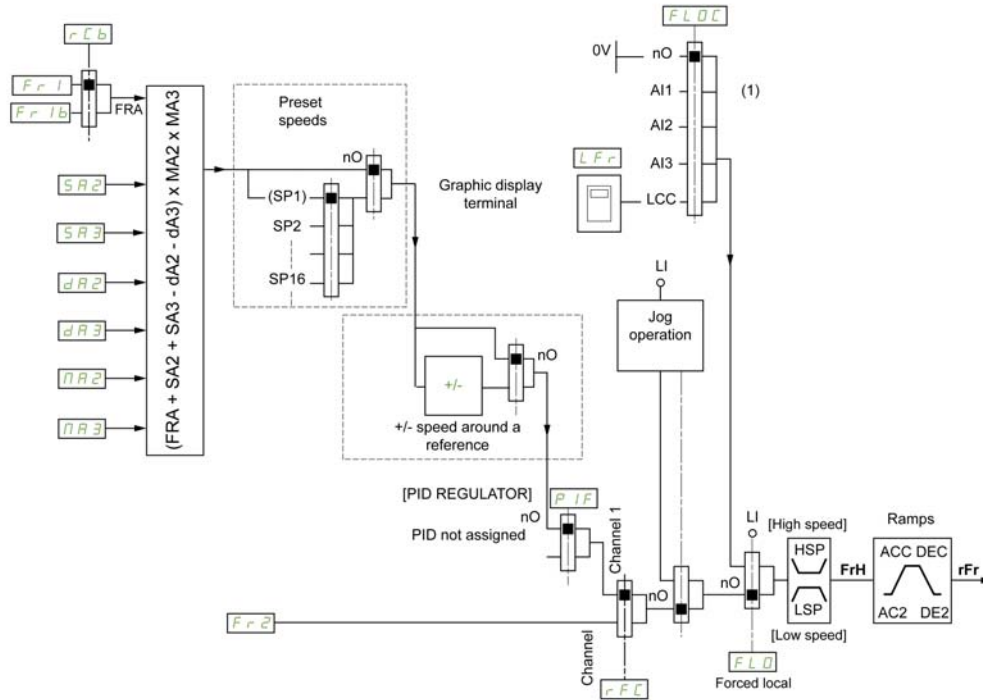

(1) Note: Forced local is not active in [I/O].

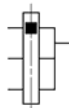

The black square represents the factory setting assignment.

Fr 1, SA2, SA3, dA2, dA3, PA2, PA3: Graphic Display Terminal, integrated Modbus serial, CANopen®, and fieldbus module.

Fr 1b, for SEP and I, O: Graphic Display Terminal, integrated Modbus, CANopen®, integrated Ethernet Modbus TCP, and fieldbus module.

Fr 1b, for S, Π: Graphic Display Terminal, only accessible if Fr 1 = terminals.

Fr 2: Graphic Display Terminal, integrated Modbus serial, CANopen®, integrated Ethernet Modbus TCP, +/- speed, and fieldbus module.

Reference Channel for [Not separ.]  $S, \Pi$ , [Separate]  $SEP$  and [I/O profile]  $\sigma$  Configurations, PID Configured with PID References at the Terminals

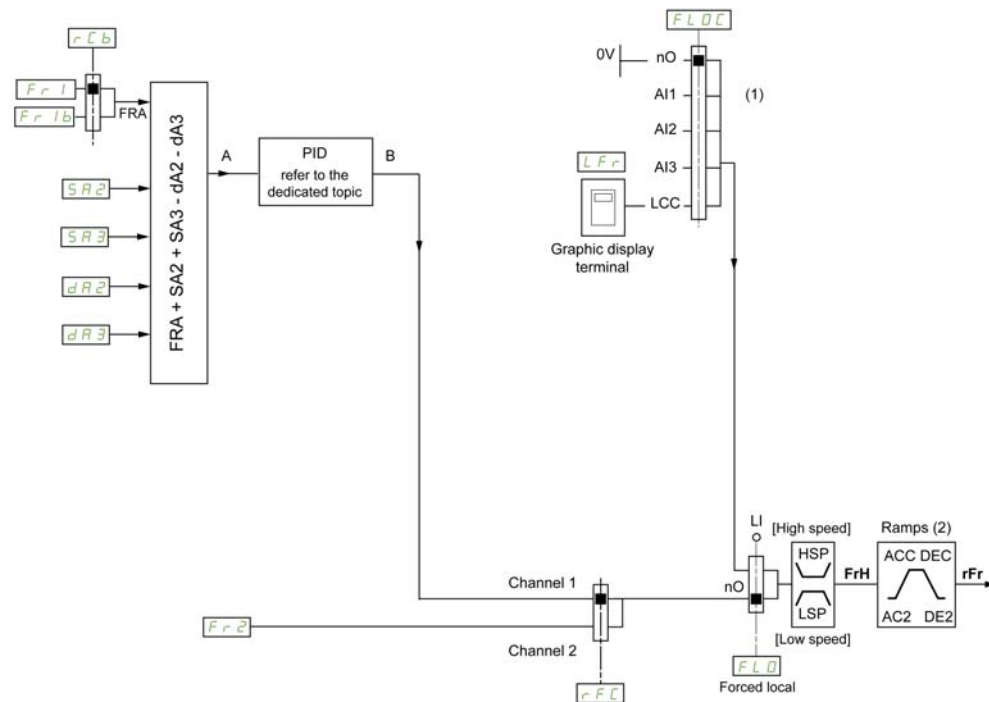

- (1) **Note:** Forced local is not active in [I/O profile].
- (2) Ramps not active if the PID function is active in automatic mode.

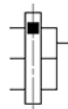

The black square represents the factory setting assignment.

$Fr1$ : Graphic Display Terminal, integrated Modbus, CANopen®, and fieldbus module.

$Fr1b$ , for  $SEP$  and  $\sigma$ : Graphic Display Terminal, integrated Modbus serial, CANopen®, and fieldbus module.

$Fr1b$ , for  $S, \Pi$ : Graphic Display Terminal, only accessible if  $Fr1$  = terminals.

$SA2, SA3, dRA2, dRA3$ : Graphic Display Terminal only.

$Fr2$ : Graphic Display Terminal, integrated Modbus serial, CANopen®, +/- speed, and fieldbus module.

**[Ref Freq 1 Config] *F r 1***

Configuration reference frequency 1.

Setting	Code / Value	Description
[Not Configured]	<i>n o</i>	Not assigned
[AI1]	<i>R , 1</i>	Analog input AI1 <b>Factory Setting</b>
[AI2]...[AI3]	<i>R , 2...R , 3</i>	Analog input AI2...AI3
[AI4]...[AI5]	<i>R , 4...R , 5</i>	Analog input AI4...AI5 if VW3A3203 I/O extension module has been inserted
[Ref Frequency via DI]	<i>u P d t</i>	Up/Down function is assigned by DIx
[Ref. Freq-Modbus]	<i>Π d b</i>	Reference frequency via Modbus
[Ref. Freq-CANopen]	<i>C R n</i>	Reference frequency via CANopen if a CANopen module has been inserted
[Ref. Freq-Com. Module]	<i>n E t</i>	Reference frequency via fieldbus module if a fieldbus module has been inserted
[Embedded Ethernet]	<i>E t H</i>	Embedded Ethernet
[PulseInput Assignment On DI5]...[PulseInput Assignment On DI6]	<i>P , 5...P , 6</i>	Digital input DI5...DI6 used as pulse input

**[Ref.1B channel] *F r 1 b***

Configuration reference frequency 1B.

Setting	Code / Value	Description
[Not Configured]	<i>n o</i>	Not assigned <b>Factory setting</b>
[AI1]...[AI3]	<i>R , 1...R , 3</i>	Analog input AI1...AI3
[AI4]...[AI5]	<i>R , 4...R , 5</i>	Analog input AI4...AI5 if VW3A3203 I/O extension module has been inserted
[PulseInput Assignment On DI5]...[PulseInput Assignment On DI6]	<i>P , 5...P , 6</i>	Digital input DI5...DI6 used as pulse input

**[Ref 1B switching] *r C b***

**WARNING**

**UNANTICIPATED EQUIPMENT OPERATION**

This parameter can cause unintended movements, for example an inversion of the direction of the rotation of the motor, a sudden acceleration or a stop.

- Verify that the setting of this parameter does not cause unintended movements.
- Verify that the setting of this parameter does not result in unsafe conditions.

**Failure to follow these instructions can result in death, serious injury, or equipment damage.**

Select switching (1 to 1B).

- If the assigned input or bit is at *D*, [Ref Freq 1 Config] *F r 1* is active.
- If the assigned input or bit is at *I*, [Ref.1B channel] *F r 1 b* is active.

[Ref 1B switching] *r C b* is forced to [Ref Freq Channel 1] *F r 1* if [Control Mode] *C H C F* is set to [Not separ.] *S , Π* with [Ref Freq 1 Config] *F r 1* assigned via the terminals (analog inputs, pulse input).

Setting	Code / Value	Description
[Ref Freq Channel 1]	<i>F r 1</i>	Reference channel = channel 1 (for RFC)
[Ref.1B channel]	<i>F r 1 b</i>	Reference channel = channel 2 (for RFC)
[DI1]...[DI6]	<i>L , 1...L , 6</i>	Digital input DI1...DI6
[DI11]...[DI16]	<i>L , 11...L , 16</i>	Digital input DI11...DI16 if VW3A3203 I/O extension module has been inserted

Setting	Code / Value	Description
[CD00]...[CD10]	C d 0 0 ... C d 1 0	Virtual digital input CMD.0...CMD.10 in <b>[I/O profile]</b> , 0 configuration
[CD11]...[CD15]	C d 1 1 ... C d 1 5	Virtual digital input CMD.11...CMD.15 regardless of configuration
[C100]...[C110]	C 1 0 0 ... C 1 1 0	Virtual digital input CMD1.0...CMD1.10 with integrated Modbus Serial in <b>[I/O profile]</b> , 0 configuration
[C111]...[C115]	C 1 1 1 ... C 1 1 5	Virtual digital input CMD1.11...CMD1.15 with integrated Modbus Serial regardless of configuration
[C200]...[C210]	C 2 0 0 ... C 2 1 0	Virtual digital input CMD2.0...CMD2.10 with CANopen® fieldbus module in <b>[I/O profile]</b> , 0 configuration
[C211]...[C215]	C 2 1 1 ... C 2 1 5	Virtual digital input CMD2.11...CMD2.15 with CANopen® fieldbus module regardless of configuration
[C300]...[C310]	C 3 0 0 ... C 3 1 0	Virtual digital input CMD3.0...CMD3.10 with a fieldbus module in <b>[I/O profile]</b> , 0 configuration
[C311]...[C315]	C 3 1 1 ... C 3 1 5	Virtual digital input CMD3.11...CMD3.15 with a fieldbus module regardless of configuration
[C500]...[C510]	C 5 0 0 ... C 5 1 0	Virtual digital input CMD5.0...CMD5.10 with integrated Ethernet ModbusTCP in <b>[I/O profile]</b> , 0 configuration
[C511]...[C515]	C 5 1 1 ... C 5 1 5	Virtual digital input CMD5.11...CMD5.15 with integrated Ethernet ModbusTCP regardless of configuration

### [Reverse Disable] r , n

Reverse directions disable.

**NOTE:** Anti-Jam function takes priority over **[Reverse Disable]** r , n function. If an Anti jam function is used, reverse direction is applied despite of the **[Reverse disable]** r , n configuration.

Lock of movement in reverse direction does not apply to direction requests sent by digital inputs.

Reverse direction requests sent by digital inputs are taken into account.

Reverse direction requests sent by the Graphic Display Terminal or sent by the line are not taken into account.

Any reverse speed reference originating from the PID, summing input, and so on, is interpreted as a zero reference (0 Hz).

Setting	Code / Value	Description
[No]	n 0	No
[Yes]	Y E 5	Yes <b>Factory Setting</b>

### [Control Mode] C H C F

Mixed mode configuration.

## WARNING

### UNANTICIPATED EQUIPMENT OPERATION

Disabling **[I/O profile]** , 0 resets the drive to the factory settings.

- Verify that restoring the factory settings is compatible with the type of wiring used.

**Failure to follow these instructions can result in death, serious injury, or equipment damage.**

Setting	Code / Value	Description
[Not separ.]	S , n	Reference and command, not separate <b>Factory Setting</b>
[Separate]	S E P	Separate reference and command. This assignment cannot be accessed in <b>[I/O profile]</b> , 0.
[I/O profile]	, 0	I/O profile

**[Command Switching] C C 5 ★**

Control channel switch.

This parameter can be accessed if **[Control Mode] C H C F** is set to **[Separate] S E P** or to **[I/O profile] I O**.

If the assigned input or bit is at 0, channel **[Cmd channel 1] C d 1** is active. If the assigned input or bit is at 1, channel **[Cmd channel 2] C d 2** is active.

**⚠ WARNING**

**UNANTICIPATED EQUIPMENT OPERATION**

This parameter can cause unintended movements, for example an inversion of the direction of the rotation of the motor, a sudden acceleration or a stop.

- Verify that the setting of this parameter does not cause unintended movements.
- Verify that the setting of this parameter does not result in unsafe conditions.

**Failure to follow these instructions can result in death, serious injury, or equipment damage.**

Setting	Code / Value	Description
<b>[Command channel 1]</b>	<i>C d 1</i>	Command channel = channel 1 (for CCS) <b>Factory setting</b>
<b>[Command channel 2]</b>	<i>C d 2</i>	Command channel = channel 2 (for CCS)
<b>[DI1]...[DI6]</b>	<i>L , I ... L , 6</i>	Digital input DI1...DI6
<b>[DI11]...[DI16]</b>	<i>L , I I ... L , 16</i>	Digital input DI11...DI16 if VW3A3203 I/O extension module has been inserted
<b>[C101]...[C110]</b>	<i>C 1 0 0 ... C 1 1 0</i>	Virtual digital input CMD1.01...CMD1.10 with integrated Modbus Serial in <b>[I/O profile] I O</b> configuration
<b>[C111]...[C115]</b>	<i>C 1 1 1 ... C 1 1 5</i>	Virtual digital input CMD1.11...CMD1.15 with integrated Modbus Serial regardless of configuration
<b>[C200]...[C210]</b>	<i>C 2 0 0 ... C 2 1 0</i>	Virtual digital input CMD2.0...CMD2.10 with CANopen® fieldbus module in <b>[I/O profile] I O</b> configuration
<b>[C211]...[C215]</b>	<i>C 2 1 1 ... C 2 1 5</i>	Virtual digital input CMD2.11...CMD2.15 with CANopen® fieldbus module regardless of configuration
<b>[C300]...[C310]</b>	<i>C 3 0 0 ... C 3 1 0</i>	Virtual digital input CMD3.0...CMD3.10 with a fieldbus module in <b>[I/O profile] I O</b> configuration
<b>[C311]...[C315]</b>	<i>C 3 1 1 ... C 3 1 5</i>	Virtual digital input CMD3.11...CMD3.15 with a fieldbus module regardless of configuration
<b>[C500]...[C510]</b>	<i>C 5 0 0 ... C 5 1 0</i>	Virtual digital input CMD5.0...CMD5.10 with integrated Ethernet ModbusTCP in <b>[I/O profile] I O</b> configuration
<b>[C511]...[C515]</b>	<i>C 5 1 1 ... C 5 1 5</i>	Virtual digital input CMD5.11...CMD5.15 with integrated Ethernet ModbusTCP regardless of configuration

**[Cmd channel 1] C d 1 ★**

Command channel 1 assignment.

This parameter can be accessed if **[Control Mode] C H C F** is set to **[Separate] S E P** or **[I/O profile] I O**.

Setting	Code / Value	Description
<b>[Terminals]</b>	<i>t E r</i>	Terminal block source <b>Factory Setting</b>
<b>[Ref. Freq- Rmt. Term]</b>	<i>L C C</i>	Reference Frequency via remote terminal
<b>[Ref. Freq-Modbus]</b>	<i>M d b</i>	Reference frequency via Modbus
<b>[Ref. Freq-CANopen]</b>	<i>C A n</i>	Reference frequency via CANopen if a CANopen module has been inserted
<b>[Ref. Freq-Com. Module]</b>	<i>n E t</i>	Reference frequency via fieldbus module if a fieldbus module has been inserted
<b>[Embedded Ethernet]</b>	<i>E t H</i>	Embedded Ethernet



**[Cmd channel 2] C d 2** ★

Command channel 2 assignment.

This parameter can be accessed if **[Control Mode] C H C F** is set to **[Separate] S E P** or **[I/O profile] i o**.  
Identical to **[Cmd channel 1] C d 1** with factory setting **[Ref. Freq- Modbus] n d b**.

**[Freq Switch Assign] r F C****⚠ WARNING****UNANTICIPATED EQUIPMENT OPERATION**

This parameter can cause unintended movements, for example an inversion of the direction of the rotation of the motor, a sudden acceleration or a stop.

- Verify that the setting of this parameter does not cause unintended movements.
- Verify that the setting of this parameter does not result in unsafe conditions.

**Failure to follow these instructions can result in death, serious injury, or equipment damage.**

frequency switching assignment.

If the assigned input or bit is at 0, channel **[Ref Freq Channel 1] F r 1** is active.

If the assigned input or bit is at 1, channel **[Ref Freq Channel 2] F r 2** is active.

Setting	Code / Value	Description
<b>[Ref Freq Channel 1]</b>	<i>F r 1</i>	Reference channel = channel 1 (for RFC)
<b>[Ref Freq Channel 2]</b>	<i>F r 2</i>	Reference channel = channel 2 (for RFC)
<b>[DI1]...[DI6]</b>	<i>L i 1...L i 6</i>	Digital input DI1...DI6
<b>[DI11]...[DI16]</b>	<i>L i 11...L i 16</i>	Digital input DI11...DI16 if VW3A3203 I/O extension module has been inserted
<b>[C101]...[C110]</b>	<i>C 1 0 0...C 1 1 0</i>	Virtual digital input CMD1.01...CMD1.10 with integrated Modbus Serial in <b>[I/O profile] i o</b> configuration
<b>[C111]...[C115]</b>	<i>C 1 1 1...C 1 1 5</i>	Virtual digital input CMD1.11...CMD1.15 with integrated Modbus Serial regardless of configuration
<b>[C200]...[C210]</b>	<i>C 2 0 0...C 2 1 0</i>	Virtual digital input CMD2.0...CMD2.10 with CANopen® fieldbus module in <b>[I/O profile] i o</b> configuration
<b>[C211]...[C215]</b>	<i>C 2 1 1...C 2 1 5</i>	Virtual digital input CMD2.11...CMD2.15 with CANopen® fieldbus module regardless of configuration
<b>[C300]...[C310]</b>	<i>C 3 0 0...C 3 1 0</i>	Virtual digital input CMD3.0...CMD3.10 with a fieldbus module in <b>[I/O profile] i o</b> configuration
<b>[C311]...[C315]</b>	<i>C 3 1 1...C 3 1 5</i>	Virtual digital input CMD3.11...CMD3.15 with a fieldbus module regardless of configuration
<b>[C500]...[C510]</b>	<i>C 5 0 0...C 5 1 0</i>	Virtual digital input CMD5.0...CMD5.10 with integrated Ethernet ModbusTCP in <b>[I/O profile] i o</b> configuration
<b>[C511]...[C515]</b>	<i>C 5 1 1...C 5 1 5</i>	Virtual digital input CMD5.11...CMD5.15 with integrated Ethernet ModbusTCP regardless of configuration
<b>[DI1 (Low level)]...[DI6 (Low level)]</b>	<i>L i L ...L i L</i>	Digital input DI1...DI6 used at low level
<b>[DI11 (Low level)]...[DI16 (Low level)]</b>	<i>L i 1 L ...L i 1 6 L</i>	Digital input DI11...DI16 used at low level if VW3A3203 I/O extension module has been inserted

**[Ref Freq 2 Config] F r 2**

Configuration reference frequency 2.

Setting	Code / Value	Description
[Not Configured]	n a	Not assigned. If [Control Mode] C H C F is set to [Not separ.] S , n , the command is at the terminals with a zero reference. If [Control Mode] C H C F is set to [Separate] S E P or [I/O profile] i a , the reference is zero. <b>Factory Setting</b>
[AI1]...[AI3]	R , 1...R , 3	Analog input AI1...AI3
[AI4]...[AI5]	R , 4...R , 5	Analog input AI4...AI5 if VW3A3203 I/O extension module has been inserted
[Ref Frequency via DI]	u P d t	+/- speed command assigned to DIx
[Ref.Freq-Rmt.Term]	L C C	Display terminal source
[Ref. Freq-Modbus]	n d b	Reference frequency via Modbus
[Ref. Freq-CANopen]	C R n	Reference frequency via CANopen if a CANopen module has been inserted
[Ref. Freq-Com. Module]	n E t	Reference frequency via fieldbus module if a fieldbus module has been inserted
[Embedded Ethernet]	E t h	Integrated Ethernet Modbus TCP
[PulseInput Assignment On DI5]...[PulseInput Assignment On DI6]	P , 5...P , 6	Digital input DI5...DI6 used as pulse input

**[Copy Ch1-Ch2] C a P** 

Copy channel 1 reference frequency to channel 2.

⚠ WARNING
<p><b>UNANTICIPATED EQUIPMENT OPERATION</b></p> <p>This parameter can cause unintended movements, for example an inversion of the direction of the rotation of the motor, a sudden acceleration or a stop.</p> <ul style="list-style-type: none"> <li>● Verify that the setting of this parameter does not cause unintended movements.</li> <li>● Verify that the setting of this parameter does not result in unsafe conditions.</li> </ul> <p><b>Failure to follow these instructions can result in death, serious injury, or equipment damage.</b></p>

Can be used to copy the current reference and/or the command with switching in order to avoid speed surges, for example.

If [Control Mode] C H C F (see page 255) is set to [Not separ.] S , n or [Separate] S E P , copying is possible only from channel 1 to channel 2.

If **[Control Mode] C H C F** is set to **[I/O profile] 1 0**, copying is possible in both directions. A reference or a command cannot be copied to a channel on the terminals. The reference copied is **[Pre-Ramp Ref Freq] F r H** (before ramp) unless the destination channel reference is set via +/- speed. In this case, the reference copied is **[Output frequency] r F r** (after ramp).

Setting	Code / Value	Description
<b>[No]</b>	<i>n 0</i>	No copy <b>Factory Setting</b>
<b>[Reference Frequency]</b>	<i>5 P</i>	Copy reference
<b>[Command]</b>	<i>C d</i>	Copy command
<b>[Cmd + Ref Frequency]</b>	<i>R L L</i>	Copy reference and command

As the Graphic Display Terminal may be selected as the command and/or reference channel, its action modes can be configured.

Comments:

- The Graphic Display Terminal command/reference is only active if the command and/or reference channels from the terminal are active except for **[T/K] F E** (command via the Graphic Display Terminal), which takes priority over these channels. Press **[T/K] F E** (command via the Graphic Display Terminal) again to revert control to the selected channel.
- Command and reference via the Graphic Display Terminal are impossible if the latter is connected to more than one drive.
- The preset PID reference functions can only be accessed if **[Control Mode] C H C F** is set to **[Not separ.] 5 1 0** or **[Separate] 5 E P**.
- The command via the Graphic Display Terminal can be accessed regardless of the **[Control Mode] C H C F**.

### [Forced Local Freq] F L 0 C

Forced local reference source assignment.

Setting	Code / Value	Description
<b>[Not Configured]</b>	<i>n 0</i>	Not assigned (control via the terminals with zero reference) <b>Factory Setting</b>
<b>[AI1]...[AI3]</b>	<i>R 1...R 3</i>	Analog input AI1...AI3
<b>[AI4]...[AI5]</b>	<i>R 4...R 5</i>	Analog input AI4...AI5 if VW3A3203 I/O extension module has been inserted
<b>[Ref.Freq-Rmt.Term]</b>	<i>L C C</i>	Display terminal source
<b>[PulseInput Assignment On DI5]...[PulseInput Assignment On DI6]</b>	<i>P 5...P 6</i>	Digital input DI5...DI6 used as pulse input

### [Time-out Forc. Local] F L 0 t ★

Time for channel confirmation after forced local.

This parameter can be accessed if **[Forced Local Assign] F L 0** is not set to **[No] n 0**.

Setting ( )	Description
0.1...30.0 s	Setting range <b>Factory setting:</b> 10.0 s

**[Forced Local Assign] F L 0**

Forced local assignment.

Forced local mode is active when the input is at state 1.

**[Forced Local Assign] F L 0** is forced to **[No] n 0** if **[Control Mode] C H C F** is set to **[I/O profile] , 0**

Setting	Code / Value	Description
<b>[Not Assigned]</b>	<b>n 0</b>	Not assigned <b>Factory setting</b>
<b>[DI1]...[DI6]</b>	<b>L , / ... L , 5</b>	Digital input DI1...DI6
<b>[DI11]...[DI16]</b>	<b>L , / / ... L , / 5</b>	Digital input DI11...DI16 if VW3A3203 I/O extension module has been inserted

**[Reverse Assign] r r 5**

Reverse assignment.

Setting	Code / Value	Description
<b>[Not Assigned]</b>	<b>n 0</b>	Not assigned <b>Factory setting</b>
<b>[DI1]...[DI6]</b>	<b>L , / ... L , 5</b>	Digital input DI1...DI6
<b>[DI11]...[DI16]</b>	<b>L , / / ... L , / 5</b>	Digital input DI11...DI16 if VW3A3203 I/O extension module has been inserted
<b>[CD00]...[CD10]</b>	<b>C d 0 0 ... C d 1 0</b>	Virtual digital input CMD.0...CMD.10 in <b>[I/O profile] , 0</b> configuration
<b>[CD11]...[CD15]</b>	<b>C d / / ... C d / 5</b>	Virtual digital input CMD.11...CMD.15 regardless of configuration
<b>[C100]...[C110]</b>	<b>C 1 0 0 ... C 1 1 0</b>	Virtual digital input CMD1.0...CMD1.10 with integrated Modbus Serial in <b>[I/O profile] , 0</b> configuration
<b>[C111]...[C115]</b>	<b>C / / / ... C / / 5</b>	Virtual digital input CMD1.11...CMD1.15 with integrated Modbus Serial regardless of configuration
<b>[C200]...[C210]</b>	<b>C 2 0 0 ... C 2 1 0</b>	Virtual digital input CMD2.0...CMD2.10 with CANopen® fieldbus module in <b>[I/O profile] , 0</b> configuration
<b>[C211]...[C215]</b>	<b>C 2 / / ... C 2 / 5</b>	Virtual digital input CMD2.11...CMD2.15 with CANopen® fieldbus module regardless of configuration
<b>[C300]...[C310]</b>	<b>C 3 0 0 ... C 3 1 0</b>	Virtual digital input CMD3.0...CMD3.10 with a fieldbus module in <b>[I/O profile] , 0</b> configuration
<b>[C311]...[C315]</b>	<b>C 3 / / ... C 3 / 5</b>	Virtual digital input CMD3.11...CMD3.15 with a fieldbus module regardless of configuration
<b>[C500]...[C510]</b>	<b>C 5 0 0 ... C 5 1 0</b>	Virtual digital input CMD5.0...CMD5.10 with integrated Ethernet Modbus TCP in <b>[I/O profile] , 0</b> configuration
<b>[C511]...[C515]</b>	<b>C 5 / / ... C 5 / 5</b>	Virtual digital input CMD5.11...CMD5.15 with integrated Ethernet Modbus TCP regardless of configuration

[2/3-wire control]  $\text{E L C}$  

2-wire or 3-wire control.

**⚠ WARNING**

**UNANTICIPATED EQUIPMENT OPERATION**

If this parameter is changed, the parameters [Reverse Assign]  $r r 5$  and [2-wire type]  $\text{E L E}$  and the assignments of the digital inputs are reset to the factory setting.

Verify that this change is compatible with the type of wiring used.

**Failure to follow these instructions can result in death, serious injury, or equipment damage.**

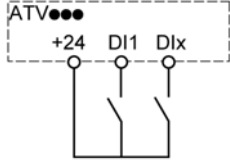
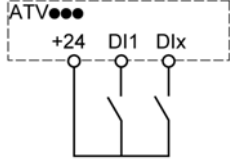
Setting	Code / Value	Description
[2-Wire Control]	$\text{Z C}$	<p><b>2-wire control (level commands):</b> This is the input state (0 or 1) or edge (0 to 1 or 1 to 0), which controls running or stopping.</p> <p>Example of <b>source</b> wiring:</p>  <p>DI1 Forward DIx Reverse</p> <p><b>Factory setting</b></p>
[3-Wire Control]	$\text{Z C}$	<p><b>3-wire control (pulse commands) [3 wire]:</b> A <b>forward</b> or <b>reverse</b> pulse is sufficient to command starting, a <b>stop</b> pulse is sufficient to command stopping.</p> <p>Example of <b>source</b> wiring:</p>  <p>DI1 Stop DI2 Forward DIx Reverse</p>

[2-wire type]  $\text{E L E}$   

Type of 2-wire control.

This parameter can be accessed if [2/3-wire control]  $\text{E L C}$  is set to [2-Wire Control]  $\text{Z C}$ .

**⚠ WARNING**

**UNANTICIPATED EQUIPMENT OPERATION**

Verify that the parameter setting is compatible with the type of wiring used.

**Failure to follow these instructions can result in death, serious injury, or equipment damage.**

Setting	Code / Value	Description
[Level]	$\text{L E L}$	State 0 or 1 is taken into account for run (1) or stop (0)
[Transition]	$\text{E r n}$	A change of state (transition or edge) is necessary to initiate operation in order to avoid accidental restarts after a break in the supply mains <b>Factory setting</b>
[Level With Fwd Priority]	$\text{P F o}$	State 0 or 1 is taken into account for run or stop, but the "forward" input takes priority over the "reverse" input

**[Stop Key Enable] P 5 5** 

Stop key enable.

⚠ WARNING
<p><b>LOSS OF CONTROL</b></p> <p>This function disables the Stop key of the Display Terminal if the setting of the parameter <b>[Command Channel] C П d C</b> is not <b>H П .</b></p> <p>Only set this parameter to <b>n o</b> if you have implemented appropriate alternative stop functions.</p> <p><b>Failure to follow these instructions can result in death, serious injury, or equipment damage.</b></p>

This is a freewheel stop. If the active command channel is the Graphic Display Terminal, the stop is performed according to the **[Type of stop] 5 5 5** irrespective of the configuration of **[Stop Key Enable] P 5 5**.

Setting	Code / Value	Description
<b>[No]</b>	<b>n o</b>	–
<b>[Yes]</b>	<b>5 5 5</b>	Gives priority to the STOP key on the Graphic Display Terminal when the Graphic Display Terminal is not enabled as the command channel. <b>Factory Setting</b>

**[HMI cmd.] b П P**

HMI command.

Setting	Code / Value	Description
<b>[Stop]</b>	<b>5 5 o P</b>	Stops the drive (although the controlled direction of operation and reference of the previous channel are copied (to be taken into account on the next RUN command)).
<b>[Bumpless]</b>	<b>b u П P</b>	Does not stop the drive (the controlled direction of operation and the reference of the previous channel are copied)
<b>[Disabled]</b>	<b>d , 5</b>	Disabled <b>Factory Setting</b>

## Section 7.7

### [Pump functions] - [Booster control]

#### Introduction

The aim of the booster control function is to maintain the desired pressure at the outlet of the pumps according to the demand by:

- Managing the velocity of the variable speed pump connected to the drive.
- Staging/De-staging the auxiliary fixed speed pumps.

#### What Is in This Section?

This section contains the following topics:

Topic	Page
[System Architecture] ПР9 - Menu	264
[Pumps configuration] Р √ ПР - Menu	269
[System Architecture] ПР9 - Menu	272
[Booster control] б 5 ∟ - Menu	273
[Stage/Destage condition] 5 д ∟ П - Menu	274
[Stage/Destage method] 5 д П П - Menu	276
[Booster control] б 5 ∟ - Menu	280

## [System Architecture] ПР9 - Menu

### Access

[Complete settings] → [Pump functions] → [Booster control] → [System architecture]

### About This Menu

This menu is used to define the equipment architecture.

The architecture is chosen by setting **[Pump System Architecture] ПPSA** to **[Single Drive] undol**: one variable speed pump and up to five fixed speed pumps.

The total number of pumps is set with **[Nb Of Pumps] ПPN**:

- With lead pump alternation, using interlocked switching relays for all pumps to connect them on mains or on the drive.
- Without lead pump alternation, using digital outputs to command the auxiliary pumps (with soft starters for example). The lead pump is always connected to the drive.

### Pump Cycling Mode

This functionality allows changing the start order of all available pumps in order to manage their wear.

There are several ways to perform the pump cycling strategy by setting **[Pump Cycling Mode] ПPCL**:

- Cycling based on pump order:
  - **[FIFO] F, Fd** mode: pumps are started and stopped in ascending order
  - **[LIFO] L, Fd** mode: pumps are started in ascending order while they are stopped in descending order
- Cycling based on running time:
  - **[Runtime] rE, PE**: the available pump with the lowest running time is started first and the running pump with the highest running time is stopped first.
  - **[Runtime&LIFO] rELF**: cycling based on a combination of running time and LIFO mode. The available pump with the lowest running time is started first and the running pump started at latest is stopped first.

### Lead Pump Alternation

The lead pump alternation function allows permuting the available pumps in order that each pump can become the lead pump (variable speed pump) instead of an auxiliary pump (fixed speed pump).

The lead pump is the first pump to be started and the last pump to be stopped. It is always associated to the variable speed drive.

The function can be activated by setting **[Lead Pump Alternation] ПPLA**:

- **[No] na**: no lead pump alternation, the pump 1 is always the lead pump. The pump cycling is applied only on auxiliary pumps.
- **[Start] YES**: the lead pump is permuted between all available pumps at each pump operation start.
- **[Redundancy] rEd**: lead pump alternation is effective only if the pump 1 is not available.

When lead pump alternation is activated, catch on fly function should be configured to reduce over current when a pump is started as the lead pump while it was running as auxiliary pump before. It is also possible to set **[Pump Ready Delay] ПP, d** to delay the availability of an auxiliary pump for a new start after it has been stopped.

### Display Parameters

A set of parameters to display the system is available in **[Display] Пon** - **[Pump parameters] ПPr** - **[Multipump System] ПPS** -:

- The state of the system **[MultiPump State] ПPS**.
- The quantity of pumps available **[Available Pumps] ПPA** and the quantity of pump already staged **[Nb of Staged Pumps] ПPSn**.
- The number of the pump selected to be the lead pump **[Lead Pump] PL, d**.
- The number of the next pump to be staged **[Next Staged Pump] PnE5** and de-staged **[Next Destaged Pump] PnEd**.
- For each pump (pump 1 in the example):
  - The state **[Pump 1 State] P1S**
  - The type **[Pump 1 Type] P1E**
  - The cumulated run time **[Pump 1 Runtime] P1oE**
  - The cumulated number of starts **[Pump 1 Nb Starts] P1nS**



### Example of Architecture Without Lead Pump Alternation and Two Fixed Speed Pumps

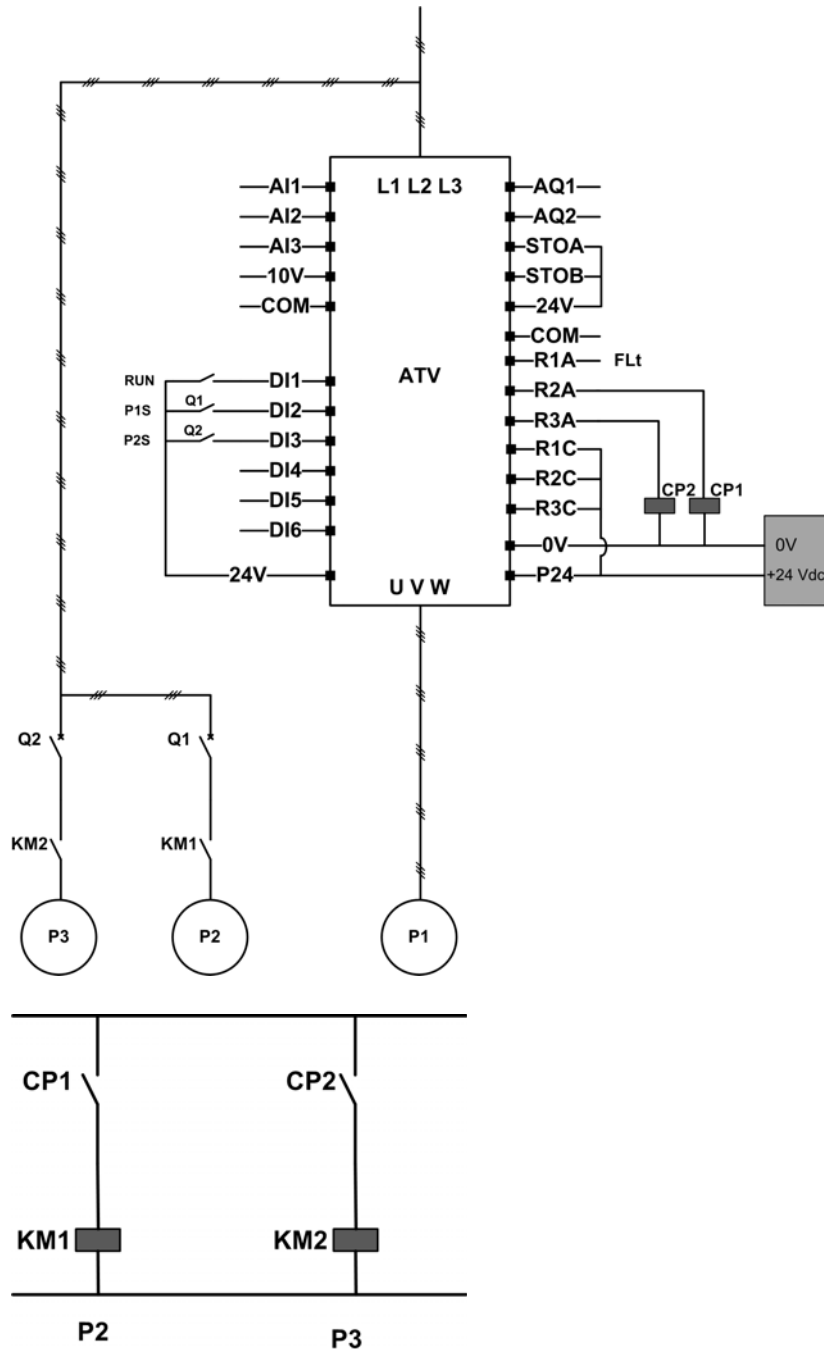

Pump 2 and pump 3 are controlled by relay outputs R2 and R3.

The state of each pump is provided to the drive via digital inputs DI2 and DI3:

- 1 = the pump is ready to operate.
- 0 = the pump is not available.

KM1 is switched ON when CP1 is activated. CP1 is controlled via the relay output R2.

KM2 is switched ON when CP2 is activated. CP2 is controlled via the relay output R3.

Q1 and Q2 must be switched ON to have both pump 2 and pump 3 ready to operate.

Example of Architecture with Lead Pump Alternation on Three Pumps

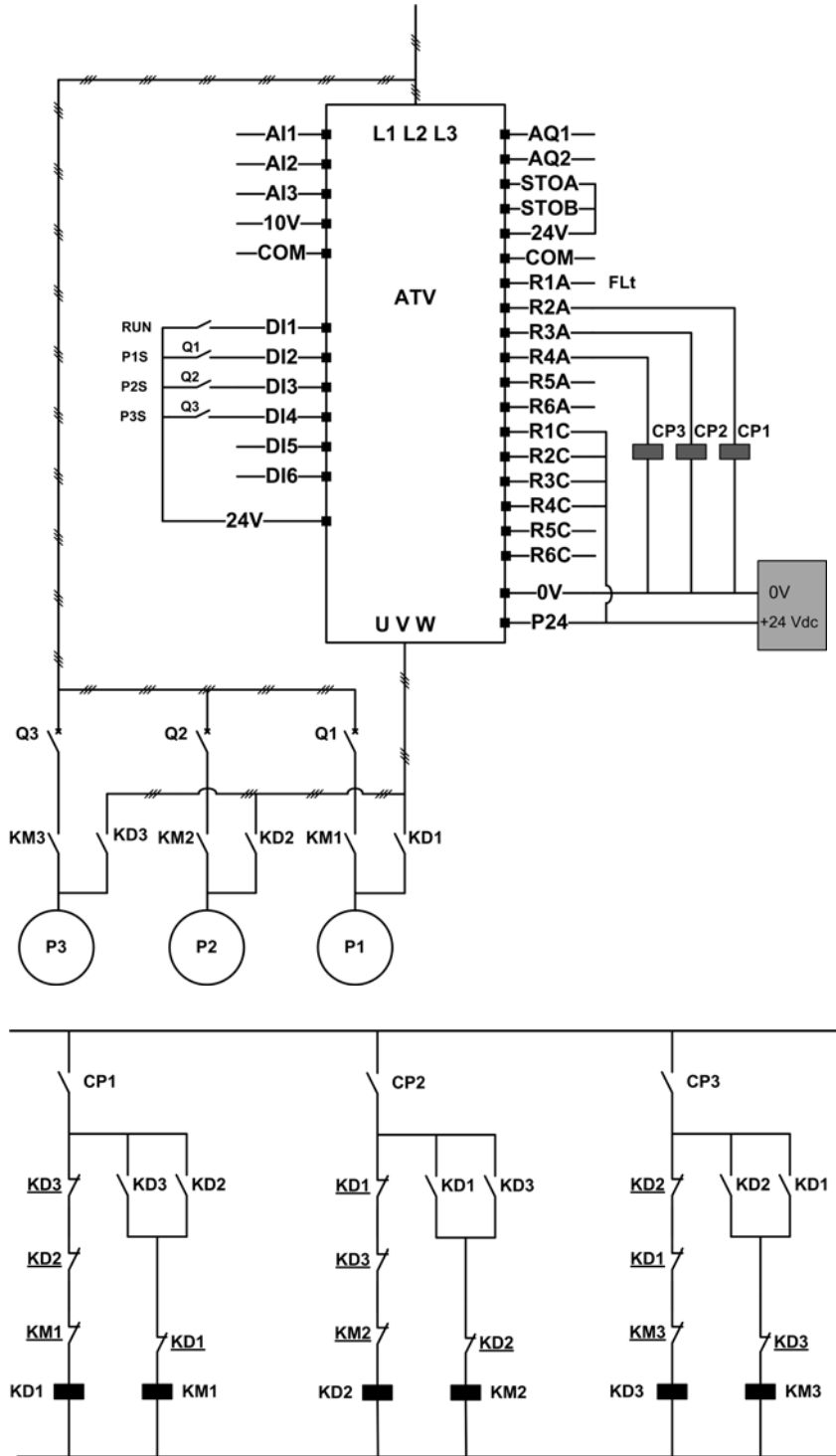

Each pump is controlled by a relay output:

- Pump 1 control via relay output R2.
- Pump 2 control via relay output R3.
- Pump 3 control via relay output R4.

The state of each pump is provided to the drive via digital inputs DI2, DI3, and DI4:

- 1 = the pump is ready to operate.
- 0 = the pump is not available.

If the relay output R2 is the first activated, the pump 1 becomes the lead pump. CP1 is switched ON via relay output R2, KD1 is switched ON and the pump 1 is connected to the drive.

The other pumps cannot be connected to the drive thanks to KD1 (switched OFF) which prevent KD2 and KD3 to be activated when CP2 and CP3 are switched ON. The other pumps become auxiliary pumps and they are connected to the supply mains trough KM2 and KM3 which are activated when, respectively, CP2 and CP3 are switched ON, that is, when R3 and R4 are activated.

When relay output R3 is the first activated, the pump 2 becomes the lead pump. The other pumps become auxiliary pumps which are connected to the supply mains via KM1 and KM3.

When relay output R4 is the first activated, the pump 3 becomes the lead pump. The other pumps become auxiliary pumps which are connected to the supply mains via KM1 and KM2.

Q1, Q2, and Q3 must be switched ON to have all pumps ready to operate.

To change the lead pump, it is necessary to deactivate all relay outputs which means that all pumps must be already stopped. It is then possible to decide which relay output to be activated first and so defining the new lead pump.

**Example of Architecture with Lead Pump Alternation on Three Pumps and Auto/Manu Switch**

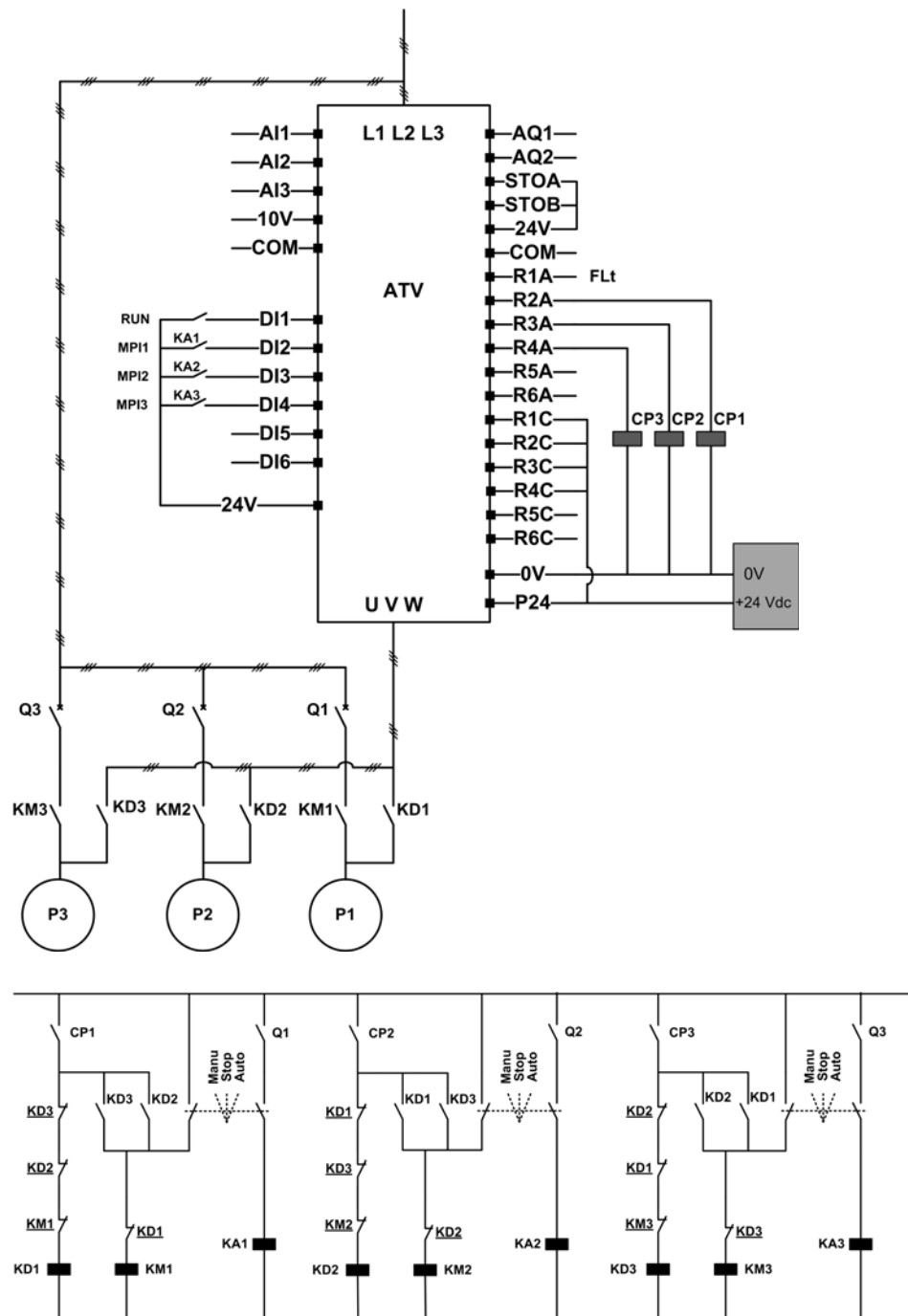

Each pump is controlled by a relay output:

- Pump 1 control via relay output R2.
- Pump 2 control via relay output R3.
- Pump 3 control via relay output R4.

The state of each pump is provided to the drive via digital inputs DI2, DI3, and DI4:

- 1 = the pump is ready to operate.
- 0 = the pump is not available (stopped or in manual mode).

In automatic mode: Same principle as previous architecture with lead pump alternation.

In manual mode: All pumps are connected to the supply mains through KM1, KM2, and KM3.

**[Pump System Architecture] *Π P S A***

Pump system architecture selection.

Setting	Code / Value	Description
[No]	<i>n o</i>	Multi-pump control deactivated <b>Factory setting</b>
[Single Drive]	<i>V n d o L</i>	Single drive with or without auxiliary pumps

**[Nb Of Pumps] *Π P P n* ★**

Number of pumps.

This parameter can be accessed if **[Pump System Architecture] *Π P S A*** is set to **[Single Drive]**

*V n d o L*.

Setting	Description
1...6	Setting range <b>Factory setting: 1</b>

## [Pumps configuration] $P \cup \cap P$ - Menu

### Access

[Complete settings] → [Pump functions] → [Booster control] → [System architecture] → [Pumps configuration]

### Input and Output Configuration for Each Pump

For each pump (pump 1 in the example), it is necessary to set:

- The drive digital output for the command: [Pump 1 Cmd Assign]  $\cap P \sigma /$  if [Lead Pump Alternation]  $\cap P L A$  is not set to [No]  $n \sigma$ .
- The drive digital input for the pump availability information: [Pump 1 Ready Assign]  $\cap P , /$ . If not configured, the pump is considered as always available.

An internal configurable delay [Pump Ready Delay]  $\cap P , d$  is available. When the digital input assigned to [Pump 1 Ready Assign]  $\cap P , /$  switches to the active state or after de-staging, the related pump is considered as not available during [Pump Ready Delay]  $\cap P , d$ .

This is used to wait that the auxiliary pumps are stopped and that all contactors between the drive and the motor (if existing) are closed before staging.

### Warnings and Errors Handling

If the available capacity of the system is exceeded:

- [MultiPump Capacity Warn]  $\cap P C A$  warning is active if the number of pumps to be started is higher than the number of available pumps.

If the selected lead pump is not available:

- A [Lead Pump Warn]  $\cap P L A$  warning is active if the lead pump becomes not available while in run or if there is no lead pump available at run command.
- A [Lead Pump Error]  $\cap P L F$  error is active if the lead pump becomes not available while in run. If configured, the delay [Pump Ready Delay]  $\cap P , d$  is applied on the error triggering if there is no lead pump available at run command.

This error is handled whatever the active command channel if booster control or level control function is configured.

The drive response to a [Lead Pump Error]  $\cap P L F$  is set with [MultiPump ErrorResp]  $\cap P F b$  parameter.

### [Pump 1 Cmd Assign] $\cap P \sigma /$ ★

Command assignment for pump 1.

This parameter can be accessed if [Nb Of Pumps]  $\cap P P n$  is set to [1]  $/$  or above.

Setting	Code / Value	Description
[No]	$n \sigma$	Not assigned <b>Factory setting</b>
[R2]...[R3]	$r 2 \dots r 3$	Relay output R2...R3
[R4]...[R6]	$r 4 \dots r 6$	Relay output R4...R6 if VW3A3204 relay output option module has been inserted
[Analog output DQ11]...[Analog output DQ12]	$d \sigma 1 1 \dots d \sigma 1 2$	Analog / digital output DO11...DO12 if VW3A3203 I/O extension module has been inserted

**[Pump 1 Ready Assign] ПР , 1 ★**

Pump 1 ready to operate assignment.

This parameter can be accessed if **[Nb Of Pumps] ПРРn** is set to **[1] 1** or above.

Setting	Code / Value	Description
[Not Assigned]	n 0	Not assigned <b>Factory setting</b>
[DI1]...[DI6]	L , 1...L , 6	Digital input DI1...DI6
[DI11]...[DI16]	L , 11...L , 16	Digital input DI11...DI16 if VW3A3203 I/O extension module has been inserted
[CD00]...[CD10]	C d 00...C d 10	Virtual digital input CMD.0...CMD.10 in <b>[I/O profile] , 0</b> configuration
[CD11]...[CD15]	C d 11...C d 15	Virtual digital input CMD.11...CMD.15 regardless of configuration
[C100]...[C110]	C 1 00...C 1 10	Virtual digital input CMD1.0...CMD1.10 with integrated Modbus Serial in <b>[I/O profile] , 0</b> configuration
[C111]...[C115]	C 1 11...C 1 15	Virtual digital input CMD1.11...CMD1.15 with integrated Modbus Serial regardless of configuration
[C200]...[C210]	C 2 00...C 2 10	Virtual digital input CMD2.0...CMD2.10 with CANopen® fieldbus module in <b>[I/O profile] , 0</b> configuration
[C211]...[C215]	C 2 11...C 2 15	Virtual digital input CMD2.11...CMD2.15 with CANopen® fieldbus module regardless of configuration
[C300]...[C310]	C 3 00...C 3 10	Virtual digital input CMD3.0...CMD3.10 with a fieldbus module in <b>[I/O profile] , 0</b> configuration
[C311]...[C315]	C 3 11...C 3 15	Virtual digital input CMD3.11...CMD3.15 with a fieldbus module regardless of configuration
[C500]...[C510]	C 5 00...C 5 10	Virtual digital input CMD5.0...CMD5.10 with integrated Ethernet Modbus TCP in <b>[I/O profile] , 0</b> configuration
[C511]...[C515]	C 5 11...C 5 15	Virtual digital input CMD5.11...CMD5.15 with integrated Ethernet Modbus TCP regardless of configuration
[DI1 (Low level)]...[DI6 (Low level)]	L 1 L ...L 6 L	Digital input DI1...DI6 used at low level
[DI11 (Low level)]...[DI16 (Low level)]	L 11 L ...L 16 L	Digital input DI11...DI16 used at low level if VW3A3203 I/O extension module has been inserted

**[Pump 2 Cmd Assign] ПР 0 2 ★**

Command assignment for pump 2.

This parameter can be accessed if **[Nb Of Pumps] ПРРn** is set to **[2] 2** or above.

Identical to **[Pump 1 Cmd Assign] ПР 0 1** (see page 269).

**[Pump 2 Ready Assign] ПР , 2 ★**

Pump 2 ready to operate assignment.

This parameter can be accessed if **[Nb Of Pumps] ПРРn** is set to **[2] 2** or above.

Identical to **[Pump 1 Ready Assign] ПР , 1** (see page 270).

**[Pump 3 Cmd Assign] ПР 0 3 ★**

Command assignment for pump 3.

This parameter can be accessed if **[Nb Of Pumps] ПРРn** is set to **[3] 3** or above.

Identical to **[Pump 1 Cmd Assign] ПР 0 1** (see page 269).

**[Pump 3 Ready Assign] ПР , 3 ★**

Pump 3 ready to operate assignment.

This parameter can be accessed if **[Nb Of Pumps] ПРРn** is set to **[3] 3** or above.

Identical to **[Pump 1 Ready Assign] ПР , 1** (see page 270).

**[Pump 4 Cmd Assign] ПР ⓐ 4 ★**

Command assignment for pump 4.

This parameter can be accessed if **[Nb Of Pumps] ПРР n** is set to **[4] 4** or above.

Identical to **[Pump 1 Cmd Assign] ПР ⓐ 1** (*see page 269*).

**[Pump 4 Ready Assign] ПР , 4 ★**

Pump 4 ready to operate assignment.

This parameter can be accessed if **[Nb Of Pumps] ПРР n** is set to **[4] 4** or above.

Identical to **[Pump 1 Ready Assign] ПР , 1** (*see page 270*).

**[Pump 5 Cmd Assign] ПР ⓐ 5 ★**

Command assignment for pump 5.

This parameter can be accessed if **[Nb Of Pumps] ПРР n** is set to **[5] 5** or above.

Identical to **[Pump 1 Cmd Assign] ПР ⓐ 1** (*see page 269*).

**[Pump 5 Ready Assign] ПР , 5 ★**

Pump 5 ready to operate assignment.

This parameter can be accessed if **[Nb Of Pumps] ПРР n** is set to **[5] 5** or above.

Identical to **[Pump 1 Ready Assign] ПР , 1** (*see page 270*).

**[Pump 6 Cmd Assign] ПР ⓐ 6 ★**

Command assignment for pump 6.

This parameter can be accessed if **[Nb Of Pumps] ПРР n** is set to **[6] 6** or above.

Identical to **[Pump 1 Cmd Assign] ПР ⓐ 1** (*see page 269*).

**[Pump 6 Ready Assign] ПР , 6 ★**

Pump 6 ready to operate assignment.

This parameter can be accessed if **[Nb Of Pumps] ПРР n** is set to **[6] 6** or above.

Identical to **[Pump 1 Ready Assign] ПР , 1** (*see page 270*).

**[System Architecture] П P 9 - Menu****Access**

[Complete settings] → [Pump functions] → [Boost control] → [System architecture]

**[Pump Cycling Mode] П P P C**

Pump cycling mode.

Setting	Code / Value	Description
[FIFO]	F I F O	First in first out
[LIFO]	L I F O	Last in first out
[Runtime]	r E I P E	Pump runtime <b>Factory setting</b>
[Runtime&LIFO]	r E L F	Runtime and Last in first out

**[Lead Pump Alternation] П P L A**

Lead pump alternation.

Setting	Code / Value	Description
[No]	n o	Deactivated <b>Factory setting</b>
[Standard]	Y E S	Standard alternation
[Redundancy]	r E d	Redundancy mode

**[Pump Ready Delay] П P I d**

Pump ready delay.

It corresponds to the stop time of the auxiliary pumps. The auxiliary pumps are considered as in running state and can not be staged during this delay, whatever the active command channel.

Setting	Description
0...3600 s	Setting range <b>Factory setting:</b> 0 s

**[MultiPump ErrorResp] П P F b**

Response to multipump error.

Setting	Code / Value	Description
[Ignore]	n o	Detected error ignored
[Freewheel Stop]	Y E S	Freewheel stop <b>Factory setting</b>
[Per STT]	S E E	Stop according to [Type of stop] S E E parameter but without an error triggered after stop
[Ramp stop]	r P P	Stop on ramp



## [Booster control] b 5 C - Menu

### Access

[Complete settings] → [Pump functions] → [Booster control] → [Booster control]

### About This Menu

This menu is used to set the booster control parameters.

### [Booster Control] b C Π

Booster control activation.

Setting	Code / Value	Description
[No]	n 0	Booster control function disabled <b>Factory setting</b>
[Yes]	Y E 5	Booster control function enabled

## [Stage/Destage condition] 5 d C Π - Menu

### Access

[Complete settings] → [Pump functions] → [Booster control] → [Booster control] → [Stage/Destage condition]

### About This Menu

It is necessary to specify how the stage and de-stage conditions are managed by setting the [Stage/Destage condition] 5 d C Π - menu:

- [Speed] 5 P d: staging/de-staging occurs according to conditions on the drive output frequency (Lead pump velocity).
- [Feedback] F b K: staging/de-staging occurs according to conditions on the outlet pressure feedback.

After a staging or de-staging condition is taken into account, no new staging or de-staging can occur during [Booster S/D Interval] b 5 d t delay. This is applied in any case, regardless of the settings of the function.

### Staging/Destaging on Speed Condition

- Staging occurs if the reference frequency stays above [Booster Stg Speed] b 5 5 for longer than [Booster Stg Delay] b 5 d.
- De-staging occurs if the reference frequency stays below [Booster Dstg Speed] b d 5 for longer than [Booster Dstg Delay] b d d.

### Staging/Destaging on Pressure Feedback Condition

- The working area [Booster Working Range] b C W R is expressed in a % of the reference value for the pressure.
- Staging occurs if PID error (taking into account [PID Inversion] P , C) stays below the working area while PID controller is at high limit speed for longer than [Booster Stg Delay] b 5 d. High limit speed corresponds to limitation speed of PID (minimum between [High Speed] H 5 P & [PID Max Output] P o H).
- De-staging occurs if PID error (taking into account [PID Inversion] P , C) stays above working area while PID controller is at low limit speed, for longer than [Booster Dstg Delay] b d d. Low limit speed corresponds to speed at which PID controller has no effect (maximum between [Low Speed] L 5 P & [PID Min Output] P o L).

### Staging/Destaging on Override

The override area is used whatever the configuration of the system and the strategy used. If the pressure feedback is out of the [Booster Override Range] b C o R range, expressed in % of the reference value for the pressure, a staging/de-staging is immediate. This increases the reactivity of the system in case of an important and rapid variation of the demand. It allows suppressing the staging/de-staging delay.

### [Booster S/D Condition] b 5 d C

Booster stage/de-stage condition.

Setting	Code / Value	Description
[Speed]	5 P d	Staging/De-staging on speed condition
[Feedback]	F b K	Staging/De-staging on pressure feedback condition <b>Factory setting</b>

### [Booster Working Range] b C W R ★

Booster working area in % of the reference value for the pressure.

This parameter can be accessed if [Booster S/D Condition] b 5 d C is set to [Feedback] F b K.

Setting ( )	Description
1.0...100.0%	Setting range in % of the reference value for the pressure <b>Factory setting: 2.0%</b>

**[Booster Stg Speed] b 5 5 ★**

Booster stage speed.

This parameter can be accessed if **[Booster S/D Condition] b 5 d C** is set to **[Speed] 5 P d**.

Setting ( )	Description
0.0...500.0 Hz	Setting range <b>Factory setting:</b> 50.0 Hz

**[Booster Dstg Speed] b d 5 ★**

Booster de-stage speed.

This parameter can be accessed if **[Booster S/D Condition] b 5 d C** is set to **[Speed] 5 P d**.

Setting ( )	Description
0.0...500.0 Hz	Setting range <b>Factory setting:</b> 40.0 Hz

**[Booster Stg Delay] b 5 d**

Booster stage delay.

Setting ( )	Description
0.0...999.9 s	Setting range <b>Factory setting:</b> 10.0 s

**[Booster Dstg Delay] b d d**

Booster de-stage delay.

Setting ( )	Description
0.0...999.9 s	Setting range <b>Factory setting:</b> 10.0 s

**[Booster Override Range] b C o R**

Booster override range.

Setting ( )	Code / Value	Description
<b>[No]</b>	n o	Booster override range disabled <b>Factory setting</b>
0.1...100.0%		Setting range

## [Stage/Destage method] 5 d n n - Menu

### Access

[Complete settings] → [Pump functions] → [Booster control] → [Booster control] → [Stage/Destage method]

### About This Menu

The stage/de-stage method is set by **[Booster S/D Control] b 5 d n** parameter:

- **[Speed] b 5 P d**: during stage/de-stage, PID controller is by-passed and a fixed reference frequency is applied.
- **[Feedback] b F b**: outlet pressure remains regulated by the PID controller during stage/de-stage.
- **[Advanced] A d V C**: outlet pressure remains regulated by the PID controller during stage/de-stage and disturbances due to stage/de-stage are taken into account by the PID controller to reduce them.

### Staging/Destaging on Speed Control

When the staging is requested, after the delay **[Booster Stg Ramp Delay] b 5 r d**, the variable speed pump output frequency is reduced to reach **[Booster Stg Bypass Spd] b 5 b 5** according to **[Booster Stg Bypass Time] b 5 b t**.

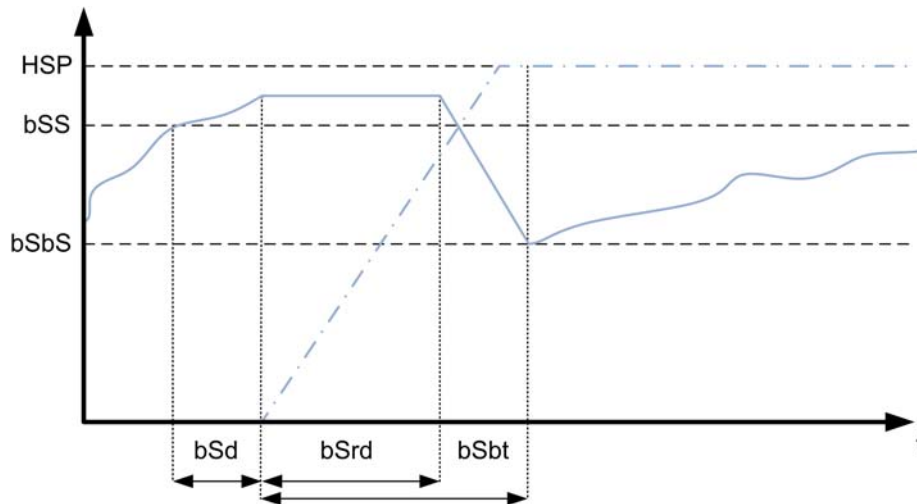

When the de-staging is requested, after the delay **[Booster Dstg Ramp Delay] b d r d**, the variable speed pump output frequency is increased to reach **[Booster Dstg Bypass Spd] b d b 5** according to **[Booster Dstg Bypass Time] b d b t**.

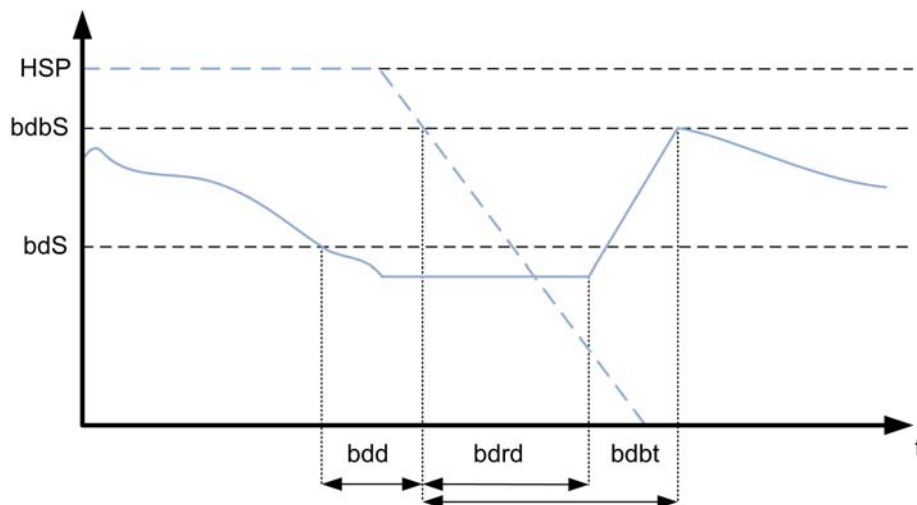

**Staging/Destaging on Pressure Feedback Control**

- When the staging is requested, a pump is started and the outlet pressure remains regulated according to the PID controller settings.
- When the de-staging is requested, a pump is stopped and the outlet pressure remains regulated according to the PID controller settings.

**Staging/Destaging on Advanced Pressure Control**

- When the staging is requested, a pump is started after the **[FeedFwd Stage Delay] F F S d** and the outlet pressure remains regulated according to the PID controller settings, in addition to a feedforward strategy to reduce the pressure overshoot.
- When the de-staging is requested, a pump is stopped after the **[FeedFwd Destage Delay] F F d d** and the outlet pressure remains regulated according to the PID controller settings, in addition to a feedforward strategy to reduce the pressure undershoot.
- The PID controller speed loop parameters should be adjusted to compensate the pressure variation linked to the normal operation of the system (close or open valves for example) without staging or de-staging a pump. The aim of the feedforward function is to reduce the overshoot or undershoot following a pump stage or de-stage. These two parameters should be set without variations generated by the system (close or open valves for example). The feedforward parameters should be adjusted after the PID controller is set.
- The **[FeedFwd Disturb Gain] F F G** parameter is a static gain that should be adjusted to reduce the maximum value of the output pressure overshoot or undershoot following a pump stage or de-stage.
- The **[FeedFwd Disturb Time] F F t G** parameter correspond to the time between the pump stage or de-stage command to the time when the maximum value of the output pressure overshoot or undershoot following a pump stage or de-stage is reached.

**[Booster S/D Control] b 5 d n**

Booster stage/de-stage control.

Setting	Code / Value	Description
[Speed]	b 5 P d	Basic speed
[Feedback]	b F b K	Basic feedback <b>Factory setting</b>
[Advanced]	A d V C	Advanced

**[Booster Stg Bypass Speed] b 5 b 5 ★**

Booster stage bypass speed.

This parameter can be accessed if **[Booster S/D Control] b 5 d n** is set to **[Speed] b 5 P d**.

Setting ( )	Description
0.0...500.0 Hz	Setting range <b>Factory setting:</b> 45.0 Hz

**[Booster Stg Bypass Time] b 5 b t ★**

Booster stage bypass time.

This parameter can be accessed if **[Booster S/D Control] b 5 d n** is set to **[Speed] b 5 P d**.

Setting ( )	Description
0.0...999.9 s	Setting range <b>Factory setting:</b> 3.0 s

**[Booster Stg Ramp Delay] b S r d ★**

Booster stage ramp delay.

This parameter can be accessed if **[Booster S/D Control] b S d Π** is set to **[Speed] b S P d**.

Setting ( )	Description
0.0...999.9 s	Setting range <b>Factory setting:</b> 1.0 s

**[Booster Dstg Bypass Spd] b d b S ★**

Booster de-stage bypass speed.

This parameter can be accessed if **[Booster S/D Control] b S d Π** is set to **[Speed] b S P d**.

Setting ( )	Description
0.0...500.0 Hz	Setting range <b>Factory setting:</b> 50.0 Hz

**[Booster Dstg Bypass Time] b d b t ★**

Booster de-stage bypass time.

This parameter can be accessed if **[Booster S/D Control] b S d Π** is set to **[Speed] b S P d**.

Setting ( )	Description
0.0...999.9 s	Setting range <b>Factory setting:</b> 1.0 s

**[Booster Dstg Ramp Delay] b d r d ★**

Booster de-stage ramp delay.

This parameter can be accessed if **[Booster S/D Control] b S d Π** is set to **[Speed] b S P d**.

Setting ( )	Description
0.0...999.9 s	Setting range <b>Factory setting:</b> 0.0 s

**[FeedFwd Stage Delay] F F S d ★**

Feed forward stage delay.

This parameter can be accessed if **[Booster S/D Control] b S d Π** is set to **[Advanced] A d V C**.

Setting ( )	Description
0.0...999.9 s	Setting range <b>Factory setting:</b> 1.0 s

**[FeedFwd Destage Delay] F F d d ★**

Feed forward de-stage delay.

This parameter can be accessed if **[Booster S/D Control] b S d Π** is set to **[Advanced] A d V C**.

Setting ( )	Description
0.0...999.9 s	Setting range <b>Factory setting:</b> 0.0 s

**[FeedFwd Disturb Gain] F F G ★**

Feed forward disturbance gain.

This parameter can be accessed if **[Booster S/D Control] b S d Π** is set to **[Advanced] # d V C**.

Setting ( )	Description
0.0...100.0%	Setting range <b>Factory setting:</b> 20.0%

**[FeedFwd Disturb Time] F F E G ★**

Feed forward disturbance time.

This parameter can be accessed if **[Booster S/D Control] b S d Π** is set to **[Advanced] # d V C**.

Setting ( )	Description
0.0...99.9 s	Setting range <b>Factory setting:</b> 3.0 s

## [Booster control] b 5 C - Menu

### Access

[Complete settings] → [Pump functions] → [Booster control] → [Booster control]

### [Booster S/D Interval] b 5 d t

Booster stage/de-stage time interval.

Setting ( )	Description
0.0...999.9 s	Setting range <b>Factory setting:</b> 15.0 s



## Section 7.8

### [Pump functions] - [Level control]

#### Introduction

The aim of the level control function is to operate:

- Filling operation
- Emptying operation

This function offers a random level functionality by changing the start and stop level after each operation (at the end of filling or emptying operation) in order to start and stop the next filling or emptying operation from different levels.

The level control function can be used for single pump or multi-pump architecture.

#### What Is in This Section?

This section contains the following topics:

Topic	Page
[System architecture] П Р 9 - Menu	282
[Pumps configuration] Р 1 П Р - Menu	283
[Level control] L c c - Menu	284
[AI1 configuration] L C A 1 - Menu	289
[AI2 configuration] L C A 2 - Menu	291
[AI3 configuration] L C A 3 - Menu	292
[AI4 configuration] L C A 4 - Menu	293
[AI5 configuration] L C A 5 - Menu	294
[AIV1 configuration] L C u 1 - Menu	295
[Level control] L c c - Menu	296
[Level settings] L c L - Menu	299

## [System architecture] П P 9 - Menu

### Access

[Complete settings] → [Pump functions] → [Level control] → [System architecture]

### About This Menu

Identical to [System architecture] П P 9 - Menu (*see page 264*).

---

## [Pumps configuration] P ∪ ∩ P - Menu

### Access

[Complete settings] → [Pump functions] → [Level control] → [System architecture] → [Pumps configuration]

### About This Menu

Identical to [Pumps configuration] P ∪ ∩ P - Menu (*see page 269*).

## [Level control] L C C - Menu

### Access

[Complete settings] → [Pump functions] → [Level control] → [Level control]

### About This Menu

The function activation is done by setting the [LevelCtrl Mode] L C M:

- [No] n o: the function is not activated.
- [Filling] F i L L: the function is activated to operate a filling operation.
- [Emptying] E m P P L Y: the function is activated to operate an emptying operation.

### System Configuration

It is necessary to specify how the level of the liquid is acquired by setting the [LevelCtrl Sensor Type] L C n t:

- [Level sensor] L E u E L or [Pressure sensor] P r E S: the level information comes from an analog sensor. The value returned by each sensor (sensor 1 in the example) is compared continuously to the configured levels [Level 1 Pump Start] L r L I and [Level 1 Pump Stop] L P L I. It is necessary to associate an analog input for the level measurement by setting [Level Sensor Assign] L C S R.
- [Level Switches] S w: the level information comes from digital inputs. In this case. The state of each digital input indicates which pump to start and which pump to stop. The quantity of level switches required is equal to [Nb Of Pumps] n P P n. It is necessary to associate digital inputs (digital input 1 in the example) for the level measurement by setting [Level Switch1 Assign] L C W I.

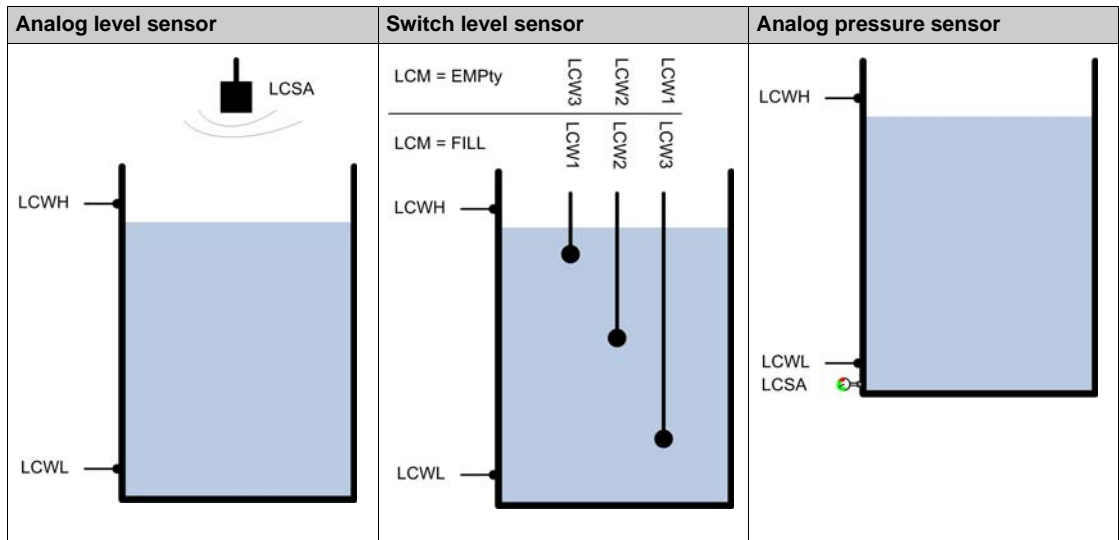

A random level factor [LevelCtrl Random Factor] L C r X can be set to reduce caking in the tank. A value of 0% deactivates the function. The start level for the first pump to start and the stop level for the last pump to stop is applied taking into account a random offset based on +/- [LevelCtrl Random Factor] L C r X %.

### Level Control Strategy

Three level control strategies are available through [LevelCtrl Strategy] L C S t parameter:

- If using an analog sensor (analog sensor level or pressure sensor), [Standard] b A S , C level control strategy and [Energy Optimized] A d u strategy are available.
- If using level switches, [Switches] t r A d strategy is available.

#### [Standard] b A S , C level control strategy

Starting and stopping pump is based on the comparison between the analog level sensor value and configured level values start and stop levels (Example for pump 1: the start level for the first pump to start [Level 1st Pump Start] L r L I and the stop level for the last pump to stop [Level 1st Pump Stop] L P L I) according to the number of used pumps in the system.

[Empty Tank Level] L C t J and [Full Tank Level] L C t K should be set to used this level control strategy.

The reference frequency follows a trajectory computed according to the level in tank.

The following figures show the principal of the basic strategy in the case of one pump for filling and emptying process:

Filling

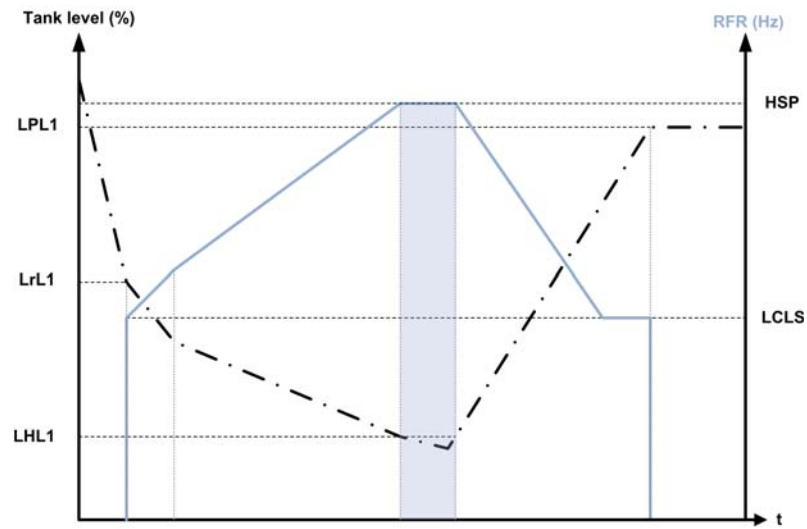

Emptying

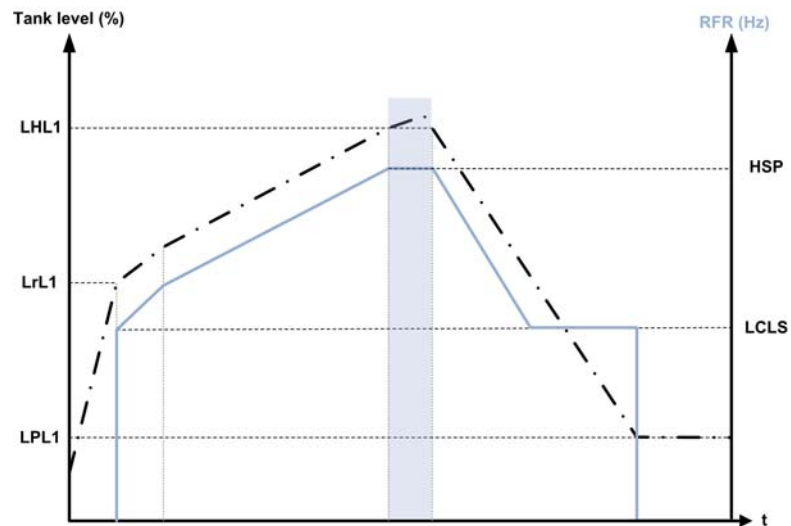

The following figures show how you can extrapolate this strategy in case of one variable speed pump and two fixed speed pumps:

Filling / three pumps

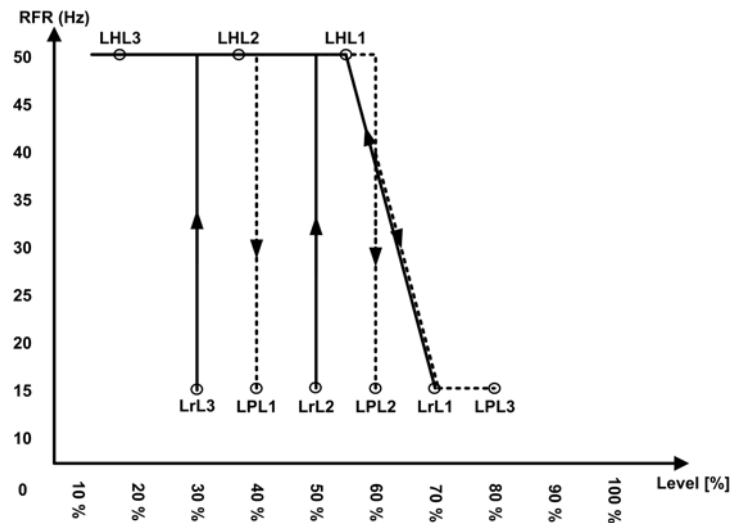

Emptying / three pumps

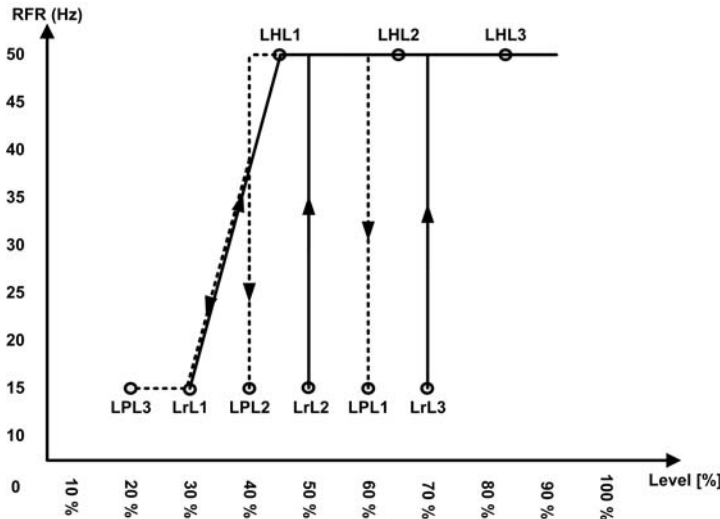

Cycle description example for emptying process with three pumps:

The variable speed pump starts at the first pump to start level **[Level 1st Pump Start] L r L 1**. If the level in the tank is still increasing, its frequency reference increases up to **[High Speed] H S P**. It corresponds to the tank level **[Level 1st Pump at HSP] L H L 1**.

When the level in the tank reaches the second pump to start **[Level 2nd Pump Start] L r L 2**, a fixed speed pump starts, the variable speed pumps is still at **[High Speed] H S P**.

When the level in the tank reaches the third pump to start level **[Level 3rd Pump Start] L r L 3**, the second fixed speed pump starts, the variable speed pumps is still at **[High Speed] H S P**.

When the level in the tank decreases under the first pump to stop level **[Level 1st Pump Stop] L P L 1**, a fixed speed pump stops, the variable speed pumps is still at **[High Speed] H S P**.

When the level in the tank decreases under second pump to stop level **[Level 2nd Pump Stop] L P L 2**, the second fixed speed pump stops, the variable speed pumps is still at **[High Speed] H S P**.

If the level in the tank is still decreasing, the frequency reference decreases up to **[LevelCtrl Low Speed] L C L 5**.

When the level in the tank decreases under the third pump to stop level **[Level 3rd Pump Stop] L P L 3**, the variable speed pump stops.

**[Energy Optimized] A d u** strategy

To perform this strategy, following data are required:

- Estimated or measured system flow.
- The volume of the tank **[Tank Volume] L C E u** and the minimum delivery height of the system **[Min Delivery Height] L C d H**.
- Validated pump curve characteristics (Hn, Pn, Qn at nominal speed). The pump curves should be configured previously in the **[Pump characteristics] P C r -** menu; pump parameterization is valid if the pump curve status **[Status] P C 5** equals to **[ACTIVE] A C E i V E**.

This strategy consists on the internal calculation of the optimal velocity profile which corresponds to the minimum of the energy consumed by the system during a filling or emptying process. The system runs at an optimal working point during the filling or emptying process.

**[Switches] t r A d** strategy

Starting and stopping pumps is based on level switches status (0: OFF or 1: ON). The variable speed pump runs at its nominal speed and the drive manages the auxiliary fixed speed pumps.

The following figure shows the principal with the switches strategy (example with 3 pumps):

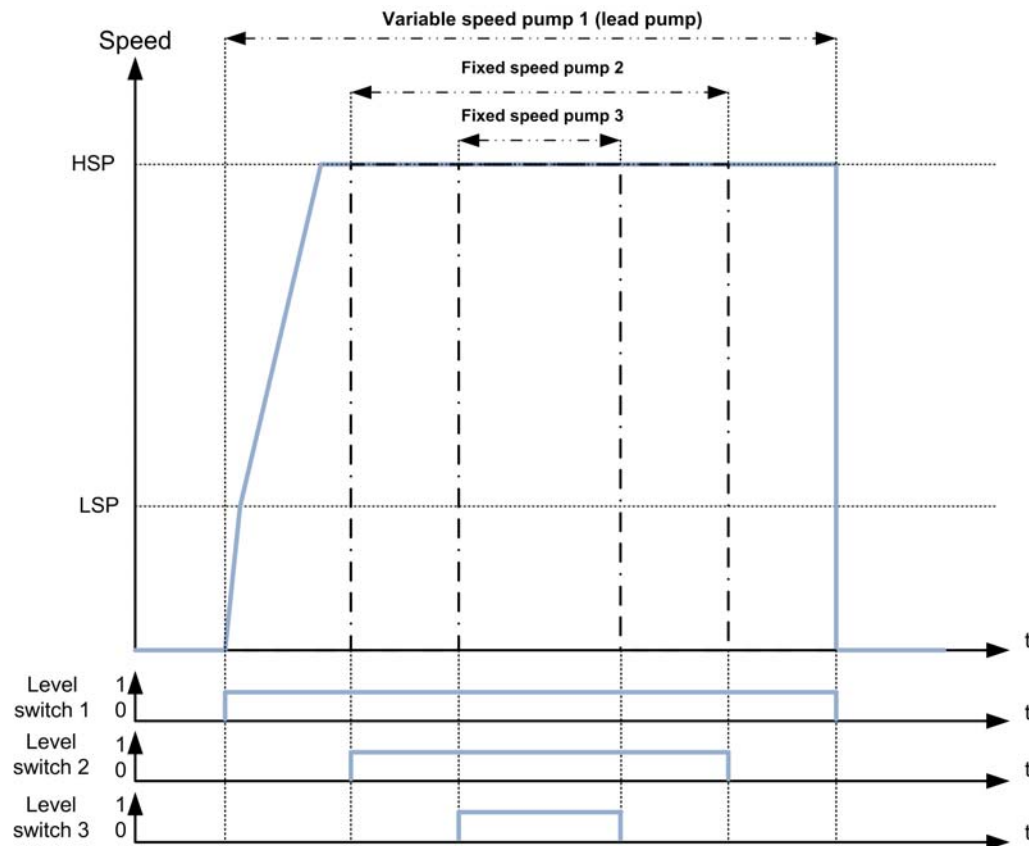

The previous example shows the way that the pumps are stopped if **[LevelCtrl Stop Mode] LC P Π** is set to **[Individual Stop] ι η δ ι υ**. It is possible to stop all the pumps at the same time when level switch 1 changes to OFF state by setting **[LevelCtrl Stop Mode] LC P Π** to **[Simultaneous Stop] ε ρ Π Π**.

### Warnings and Errors Handling

- A **[High Level Warning] LC H R** warning is active if the maximum level switch defined by **[Max Level Switch Assign] LC W L** is active.  
If it occurs during filling process, a **[High Level Error] LC H F** error is activated.
- A **[Low Level Warning] LC L R** warning is active if the minimum level switch defined by **[Min Level Switch Assign] LC W H** is active.  
If it occurs during emptying process, a **[Low Level Error] LC L F** error is activated.
- All pumps are stopped in case of **[High Level Error] LC H F** or **[Low Level Error] LC L F** error, whatever the setting of **[LevelCtrl Error Resp] LC F b**.
- A **[Level Switch Warning] LC W R** warning is active in case of an inconsistent feedback from the level switches (for example, if the level switches 1 and 3 are active and the level switch 2 is inactive).

### [LevelCtrl Mode] LC Π

Level control mode.

Setting	Code / Value	Description
[No]	η ρ	Deactivated <b>Factory setting</b>
[Filling]	F ι L L	Filling mode
[Emptying]	E Π P E Y	Emptying mode

**[LevelCtrl Sensor Type] L C n t ★**

Level control sensor type.

This parameter can be accessed if **[LevelCtrl Mode] L c n** is not set to **[No] n o**.

Setting	Code / Value	Description
<b>[Level Switches]</b>	<b>5W</b>	Level switches <b>Factory setting</b>
<b>[Level Sensor]</b>	<b>L E V E L</b>	Level sensor
<b>[Pressure Sensor]</b>	<b>P r E S</b>	Pressure sensor

**[LevelCtrl Strategy] L C S t ★**

Level control strategy.

This parameter can be accessed if **[LevelCtrl Mode] L c n** is not set to **[No] n o**.

Setting	Code / Value	Description
<b>[Switches]</b>	<b>t r A d</b>	Switches <b>Factory setting</b>
<b>[Standard]</b>	<b>b A S i c</b>	Standard
<b>[Energy Optimized]</b>	<b>A d V</b>	Energy optimized

**[Level Sensor Assign] L C S A ★**

Level sensor assignment.

This parameter can be accessed if:

- **[LevelCtrl Mode] L C n** is not set to **[No] n o**, and
- **[LevelCtrl Sensor Type] L C n t** is not set to **[Level Switches] L 5**

This parameter can be accessed if **[Application Selection] A P P L** is set to **[Level] L E V E L**.

Setting	Code / Value	Description
<b>[Not Configured]</b>	<b>n o</b>	Not assigned <b>Factory setting</b>
<b>[AI1]...[AI3]</b>	<b>A , 1...A , 3</b>	Analog input AI1...AI3
<b>[AI4]...[AI5]</b>	<b>A , 4...A , 5</b>	Analog input AI4...AI5 if VW3A3203 I/O extension module has been inserted
<b>[AI Virtual 1]</b>	<b>A , V 1</b>	Virtual analogic input 1



**[AI1 configuration] L C R I - Menu****Access**

[Complete settings] → [Pump functions] → [Level control] → [AI1 configuration]

**[AI1 Type] R , I E**

Configuration of analog input AI1.

Setting	Code / Value	Description
[Voltage]	I D u	0-10 Vdc <b>Factory setting</b>
[Current]	D R	0-20 mA

**[AI1 min value] u , L I ★**

AI1 voltage scaling parameter of 0%.

This parameter can be accessed if [AI1 Type] R , I E is set to [Voltage] I D u.

Setting	Description
0.0...10.0 Vdc	Setting range <b>Factory setting:</b> 0.0 Vdc

**[AI1 max value] u , H I ★**

AI1 voltage scaling parameter of 100%.

This parameter can be accessed if [AI1 Type] R , I E is set to [Voltage] I D u.

Setting	Description
0.0...10.0 Vdc	Setting range <b>Factory setting:</b> 10.0 Vdc

**[AI1 min. value] C r L I ★**

AI1 current scaling parameter of 0%.

This parameter can be accessed if [AI1 Type] R , I E is set to [Current] D R.

Setting	Description
0.0...20.0 mA	Setting range <b>Factory setting:</b> 0.0 mA

**[AI1 max. value] C r H I ★**

AI1 current scaling parameter of 100%.

This parameter can be accessed if [AI1 Type] R , I E is set to [Current] D R.

Setting	Description
0.0...20.0 mA	Setting range <b>Factory setting:</b> 20.0 mA

**[A11 Lowest Process] R , I J**

A11 lowest process.

Setting	Description
-32,767...32,767	Setting range. Value in application customer unit <b>Factory setting:</b> 0

**[A11 Highest Process] R , I K**

A11 highest process.

Setting	Description
-32,767...32,767	Setting range. Value in application customer unit <b>Factory setting:</b> 0

## [AI2 configuration] L C R 2 - Menu

### Access

[Complete settings] → [Pump functions] → [Level control] → [AI2 configuration]

### [AI2 Type] R , 2 E

Configuration of analog input AI2.

Setting	Code / Value	Description
[Voltage]	1 0 U	0-10 Vdc Factory setting
[Current]	0 R	0-20 mA
[PTC Management]	P E C	1 to 6 PTC (in serial)
[KTY]	K E Y	1 KTY84
[PT1000]	1 P E 3	1 PT1000 connected with 2 wires
[PT100]	1 P E 2	1 PT100 connected with 2 wires
[Water Prob]	L E U E L	Water level
[3PT1000]	3 P E 3	3 PT1000 connected with 2 wires
[3PT100]	3 P E 2	3 PT100 connected with 2 wires

### [AI2 min value] U , L 2 ★

AI2 voltage scaling parameter of 0%.

This parameter can be accessed if [AI2 Type] R , 2 E is set to [Voltage] 1 0 U.

Identical to [AI1 min value] U , L 1 (see page 289).

### [AI2 max value] U , H 2 ★

AI2 voltage scaling parameter of 100%.

This parameter can be accessed if [AI2 Type] R , 2 E is set to [Voltage] 1 0 U.

Identical to [AI1 max value] U , H 1 (see page 289).

### [AI2 min. value] C r L 2 ★

AI2 current scaling parameter of 0%.

This parameter can be accessed if [AI2 Type] R , 2 E is set to [Current] 0 R.

Identical to [AI1 min. value] C r L 1 (see page 289).

### [AI2 max. value] C r H 2 ★

AI2 current scaling parameter of 100%.

This parameter can be accessed if [AI2 Type] R , 2 E is set to [Current] 0 R.

Identical to [AI1 max. value] C r H 1 (see page 289).

### [AI2 Lowest Process] R , 2 J

AI2 lowest process.

Identical to [AI1 Lowest Process] R , 1 J (see page 290).

### [AI2 Highest Process] R , 2 K

AI2 highest process.

Identical to [AI1 Highest Process] R , 1 K (see page 290).

## [AI3 configuration] L C R E - Menu

### Access

[Complete settings] → [Pump functions] → [Level control] → [AI3 configuration]

### [AI3 Type] R , E E

Configuration of analog input AI3.

Identical to [AI2 Type] R , E E with factory setting: [Current] D R (see page 291).

### [AI3 min value] U , L E ★

AI3 voltage scaling parameter of 0%.

This parameter can be accessed if [AI2 Type] R , E E is set to [Voltage] I D U.

Identical to [AI1 min value] U , L I (see page 289).

### [AI3 max value] U , H E ★

AI3 voltage scaling parameter of 100%.

This parameter can be accessed if [AI3 Type] R , E E is set to [Voltage] I D U.

Identical to [AI1 max value] U , H I (see page 289).

### [AI3 min. value] C r L E ★

AI3 current scaling parameter of 0%.

This parameter can be accessed if [AI3 Type] R , E E is set to [Current] D R.

Identical to [AI1 min. value] C r L I (see page 289).

### [AI3 max. value] C r H E ★

AI3 current scaling parameter of 100%.

This parameter can be accessed if [AI3 Type] R , E E is set to [Current] D R.

Identical to [AI1 max. value] C r H I (see page 289).

### [AI3 Lowest Process] R , E J

AI3 lowest process.

Identical to [AI1 Lowest Process] R , I J (see page 290).

### [AI3 Highest Process] R , E K

AI3 highest process.

Identical to [AI1 Highest Process] R , I K (see page 290).

**[AI4 configuration] L C R 4 - Menu****Access**

[Complete settings] → [Pump functions] → [Level control] → [AI4 configuration]

**[AI4 Type] R , 4 E ★**

Configuration of analog input AI4.

This parameter can be accessed if VW3A3203 I/O extension module has been inserted.

Setting	Code / Value	Description
[Voltage]	I 0 u	0-10 Vdc
[Current]	0 R	0-20 mA
[Voltage +/-]	n I 0 u	-10/+10 Vdc <b>Factory setting</b>
[PTC Management]	P E C	1 to 6 PTC (in serial)
[KTY]	K E Y	1 KTY84
[PT1000]	I P E 3	1 PT1000 connected with 2 wires
[PT100]	I P E 2	1 PT100 connected with 2 wires
[3 PT1000]	3 P E 3	3 PT1000 connected with 2 wires
[3 PT100]	3 P E 2	3 PT100 connected with 2 wires
[PT1000 in 3 wires]	I P E 3 3	1 PT1000 connected with 3 wires (AI4 & AI5 only)
[PT100 in 3 wires]	I P E 2 3	1 PT100 connected with 3 wires (AI4 & AI5 only)
[3 PT1000 in 3 wires]	3 P E 3 3	3 PT1000 connected with 3 wires (AI4 & AI5 only)
[3 PT100 in 3 wires]	3 P E 2 3	3 PT100 connected with 3 wires (AI4 & AI5 only)

**[AI4 min value] u , L 4 ★**

AI4 voltage scaling parameter of 0%.

Identical to [AI1 min value] u , L 1 (see page 289).

**[AI4 max value] u , H 4 ★**

AI4 voltage scaling parameter of 100%.

Identical to [AI1 max value] u , H 1 (see page 289).

**[AI4 min. value] C r L 4 ★**

AI4 current scaling parameter of 0%.

Identical to [AI1 min. value] C r L 1 (see page 289).

**[AI4 max. value] C r H 4 ★**

AI4 current scaling parameter of 100%.

Identical to [AI1 max. value] C r H 1 (see page 289).

**[AI4 Lowest Process] R , 4 J**

AI4 lowest process.

Identical to [AI1 Lowest Process] R , 1 J (see page 290).

**[AI4 Highest Process] R , 4 K**

AI4 highest process.

Identical to [AI1 Highest Process] R , 1 K (see page 290).

## [AI5 configuration] L C H 5 - Menu

### Access

[Complete settings] → [Pump functions] → [Level control] → [AI5 configuration]

### [AI5 Type] H , 5 E ★

Configuration of analog input AI5.

This parameter can be accessed if VW3A3203 I/O extension module has been inserted.

Identical to [AI4 Type] H , 4 E (see page 293).

### [AI5 min value] U , L 5 ★

AI5 voltage scaling parameter of 0%.

Identical to [AI1 min value] U , L 1 (see page 289).

### [AI5 max value] U , H 5 ★

AI5 voltage scaling parameter of 100%.

Identical to [AI1 max value] U , H 1 (see page 289).

### [AI5 min. value] C r L 5 ★

AI5 current scaling parameter of 0%.

Identical to [AI1 min. value] C r L 1 (see page 289).

### [AI5 max. value] C r H 5 ★

AI5 current scaling parameter of 100%.

Identical to [AI1 max. value] C r H 1 (see page 289).

### [AI5 Lowest Process] H , 5 J

AI5 lowest process.

Identical to [AI1 Lowest Process] H , 1 J (see page 290).

### [AI5 Highest Process] H , 5 K

AI5 highest process.

Identical to [AI1 Highest Process] H , 1 K (see page 290).

**[AIV1 configuration] L C U I - Menu****Access**

[Complete settings] → [Pump functions] → [Level control] → [AIV1 configuration]

**[AIV1 Channel Assignment] A , C I**

Channel assignment for virtual analog input AIV1.

Setting	Code / Value	Description
[Not Configured]	n a	Not assigned <b>Factory setting</b>
[Ref. Freq-Modbus]	n d b	Reference frequency via Modbus
[Ref. Freq-CANopen]	C A n	Reference frequency via CANopen if a CANopen module has been inserted
[Ref. Freq-Com. Module]	n E t	Reference frequency via fieldbus module if a fieldbus module has been inserted
[Embedded Ethernet]	E t H	Embedded Ethernet

**[AIV1 Lowest Process] A U I J**

AI virtual x: minimum process value.

Setting	Description
-32,767...32,767	Setting range <b>Factory setting: 0</b>

**[AIV1 Highest Process] A U I K**

AI virtual x: maximum process value.

Setting	Description
-32,767...32,767	Setting range <b>Factory setting: 0</b>

**[Level control] L c c - Menu**

**Access**

[Complete settings] → [Pump functions] → [Level control] → [Level control]

**About This Menu**

This menu can be accessed if [Pump System Architecture] *Π P S A* is not set to [No] *n o*.

**[Min Level Switch Assign] L c W L ★**

Minimum level switch assignment.

This parameter can be accessed if [LevelCtrl Mode] *L c Π* is not set to [No] *n o*.

Setting	Code / Value	Description
[Not Assigned]	<i>n o</i>	Not assigned <b>Factory setting</b>
[DI1]...[DI6]	<i>L , l ... L , l 6</i>	Digital input DI1...DI6
[DI11]...[DI16]	<i>L , l l ... L , l l 6</i>	Digital input DI11...DI16 if VW3A3203 I/O extension module has been inserted
[CD00]...[CD10]	<i>C d 0 0 ... C d 1 0</i>	Virtual digital input CMD.0...CMD.10 in [I/O profile] , <i>o</i> configuration
[CD11]...[CD15]	<i>C d 1 1 ... C d 1 5</i>	Virtual digital input CMD.11...CMD.15 regardless of configuration
[C100]...[C110]	<i>C 1 0 0 ... C 1 1 0</i>	Virtual digital input CMD1.0...CMD1.10 with integrated Modbus Serial in [I/O profile] , <i>o</i> configuration
[C111]...[C115]	<i>C 1 1 1 ... C 1 1 5</i>	Virtual digital input CMD1.11...CMD1.15 with integrated Modbus Serial regardless of configuration
[C200]...[C210]	<i>C 2 0 0 ... C 2 1 0</i>	Virtual digital input CMD2.0...CMD2.10 with CANopen® fieldbus module in [I/O profile] , <i>o</i> configuration
[C211]...[C215]	<i>C 2 1 1 ... C 2 1 5</i>	Virtual digital input CMD2.11...CMD2.15 with CANopen® fieldbus module regardless of configuration
[C300]...[C310]	<i>C 3 0 0 ... C 3 1 0</i>	Virtual digital input CMD3.0...CMD3.10 with a fieldbus module in [I/O profile] , <i>o</i> configuration
[C311]...[C315]	<i>C 3 1 1 ... C 3 1 5</i>	Virtual digital input CMD3.11...CMD3.15 with a fieldbus module regardless of configuration
[C500]...[C510]	<i>C 5 0 0 ... C 5 1 0</i>	Virtual digital input CMD5.0...CMD5.10 with integrated Ethernet Modbus TCP in [I/O profile] , <i>o</i> configuration
[C511]...[C515]	<i>C 5 1 1 ... C 5 1 5</i>	Virtual digital input CMD5.11...CMD5.15 with integrated Ethernet Modbus TCP regardless of configuration

**[Max Level Switch Assign] L c W h ★**

Maximum level switch assignment.

This parameter can be accessed if [LevelCtrl Mode] *L c Π* is not set to [No] *n o*.

Setting	Code / Value	Description
[Not Assigned]	<i>n o</i>	Not assigned <b>Factory setting</b>
[DI1]...[DI6]	<i>L , l ... L , l 6</i>	Digital input DI1...DI6
[DI11]...[DI16]	<i>L , l l ... L , l l 6</i>	Digital input DI11...DI16 if VW3A3203 I/O extension module has been inserted
[CD00]...[CD10]	<i>C d 0 0 ... C d 1 0</i>	Virtual digital input CMD.0...CMD.10 in [I/O profile] , <i>o</i> configuration
[CD11]...[CD15]	<i>C d 1 1 ... C d 1 5</i>	Virtual digital input CMD.11...CMD.15 regardless of configuration
[C100]...[C110]	<i>C 1 0 0 ... C 1 1 0</i>	Virtual digital input CMD1.0...CMD1.10 with integrated Modbus Serial in [I/O profile] , <i>o</i> configuration
[C111]...[C115]	<i>C 1 1 1 ... C 1 1 5</i>	Virtual digital input CMD1.11...CMD1.15 with integrated Modbus Serial regardless of configuration
[C200]...[C210]	<i>C 2 0 0 ... C 2 1 0</i>	Virtual digital input CMD2.0...CMD2.10 with CANopen® fieldbus module in [I/O profile] , <i>o</i> configuration



Setting	Code / Value	Description
[C211]...[C215]	C 2 1 1 ... C 2 1 5	Virtual digital input CMD2.11...CMD2.15 with CANopen® fieldbus module regardless of configuration
[C300]...[C310]	C 3 0 0 ... C 3 1 0	Virtual digital input CMD3.0...CMD3.10 with a fieldbus module in <b>[I/O profile]</b> configuration
[C311]...[C315]	C 3 1 1 ... C 3 1 5	Virtual digital input CMD3.11...CMD3.15 with a fieldbus module regardless of configuration
[C500]...[C510]	C 5 0 0 ... C 5 1 0	Virtual digital input CMD5.0...CMD5.10 with integrated Ethernet Modbus TCP in <b>[I/O profile]</b> configuration
[C511]...[C515]	C 5 1 1 ... C 5 1 5	Virtual digital input CMD5.11...CMD5.15 with integrated Ethernet Modbus TCP regardless of configuration

### [Tank Volume] L C E U ★

Tank volume to be filled or emptied.

This parameter can be accessed if **[LevelCtrl Strategy] L c 5 E** is set to **[Energy Optimized] R d U**.

Setting	Description
0...32,767	Setting range according to <b>[Flow rate unit] 5 u F r</b> <b>Factory setting:</b> 0

### [LevelCtrl Low Speed] L C L S ★

Level control low speed.

This parameter can be accessed if **[LevelCtrl Strategy] L c 5 E** is set to **[Standard] b R S i c**.

Setting ( )	Description
0.0...500.0 Hz	Setting range <b>Factory setting:</b> 35.0 Hz

### [LevelCtrl Random Factor] L C r X ★

Level control random factor.

This parameter can be accessed if **[LevelCtrl Mode] L c P** is not set to **[No] n o**.

Setting ( )	Description
0...100%	Setting range <b>Factory setting:</b> 0%

### [LevelCtrl Stop Mode] L C P P ★

Level control stop mode.

This parameter can be accessed if **[LevelCtrl Strategy] L c 5 E** is not set to **[Switches] E r R d**.

Setting	Code / Value	Description
<b>[Simultaneous Stop]</b>	c o P P	All pumps stopped simultaneously
<b>[Individual Stop]</b>	i n d i V	Each pump stopped individually <b>Factory setting</b>

**[Empty Tank Level] L C E J ★**

Empty tank level sensor value.

This parameter can be accessed if **[LevelCtrl Strategy] L c 5 E** is not set to **[Switches] E r A d**.

Setting	Description
-32,767...32,767 m	Setting range in meter or in pressure value according to <b>[LevelCtrl Sensor Type] L C n E</b> <b>Factory setting:</b> 0.00 m

**[Full Tank Level] L C E K ★**

Full tank level sensor value.

This parameter can be accessed if **[LevelCtrl Strategy] L c 5 E** is not set to **[Switches] E r A d**.

Setting	Description
-32,767...32,767 m	Setting range in meter or in pressure value according to <b>[LevelCtrl Sensor Type] L C n E</b> <b>Factory setting:</b> 0.00 m

**[Min Delivery Height] L C d h ★**

Minimum delivery height.

This parameter can be accessed if **[LevelCtrl Strategy] L c 5 E** is set to **[Energy Optimized] A d u**.

Setting	Description
0.00...327.67 m	Setting range according to <b>[Flow rate unit] 5 u F r</b> <b>Factory setting:</b> 0.00 m

**[LevelCtrl Error Resp] L C F b ★**

Level control error response.

This parameter can be accessed if **[LevelCtrl Mode] L c n** is not set to **[No] n o**.

Setting	Code / Value	Description
<b>[Ignore]</b>	<b>n o</b>	Detected error ignored
<b>[Freewheel Stop]</b>	<b>5 E 5</b>	Freewheel stop <b>Factory setting</b>
<b>[Per STT]</b>	<b>5 E E</b>	Stop according to <b>[Type of stop] 5 E E</b> parameter but without an error triggered after stop
<b>[Ramp stop]</b>	<b>r n P</b>	Stop on ramp

## [Level settings] L c L - Menu

### Access

[Complete settings] → [Pump functions] → [Level control] → [Level settings]

### About This Menu

According to the configured [LevelCtrl Strategy] L C S E , it is necessary to assign:

- Digital inputs for the level switches, in case of [Switches] E r A d has been selected.
- Levels in % for the next pump to start, for next pump to stop, and for the pump at high speed, in case of [Standard] b A S , C or [Energy Optimized] A d u level control strategy has been selected.

### [Level Switch1 Assign] L c W 1 ★

Level switch 1 assignment.

This parameter can be accessed if:

- [LevelCtrl Strategy] L C S E is set to [Switches] E r A d, and
- [Nb Of Pumps] P P P n is higher than 0.

Setting	Code / Value	Description
[Not Assigned]	n o	Not assigned <b>Factory setting</b>
[DI1]...[DI6]	L , I ... L , 6	Digital input DI1...DI6
[DI11]...[DI16]	L , I I ... L , 16	Digital input DI11...DI16 if VW3A3203 I/O extension module has been inserted
[CD00]...[CD10]	C d 0 0 ... C d 1 0	Virtual digital input CMD.0...CMD.10 in [I/O profile] , o configuration
[CD11]...[CD15]	C d 1 1 ... C d 1 5	Virtual digital input CMD.11...CMD.15 regardless of configuration
[C100]...[C110]	C 1 0 0 ... C 1 1 0	Virtual digital input CMD1.0...CMD1.10 with integrated Modbus Serial in [I/O profile] , o configuration
[C111]...[C115]	C 1 1 1 ... C 1 1 5	Virtual digital input CMD1.11...CMD1.15 with integrated Modbus Serial regardless of configuration
[C200]...[C210]	C 2 0 0 ... C 2 1 0	Virtual digital input CMD2.0...CMD2.10 with CANopen® fieldbus module in [I/O profile] , o configuration
[C211]...[C215]	C 2 1 1 ... C 2 1 5	Virtual digital input CMD2.11...CMD2.15 with CANopen® fieldbus module regardless of configuration
[C300]...[C310]	C 3 0 0 ... C 3 1 0	Virtual digital input CMD3.0...CMD3.10 with a fieldbus module in [I/O profile] , o configuration
[C311]...[C315]	C 3 1 1 ... C 3 1 5	Virtual digital input CMD3.11...CMD3.15 with a fieldbus module regardless of configuration
[C500]...[C510]	C 5 0 0 ... C 5 1 0	Virtual digital input CMD5.0...CMD5.10 with integrated Ethernet Modbus TCP in [I/O profile] , o configuration
[C511]...[C515]	C 5 1 1 ... C 5 1 5	Virtual digital input CMD5.11...CMD5.15 with integrated Ethernet Modbus TCP regardless of configuration

### [Level Switch2 Assign] L c W 2 ★

Level switch 2 assignment.

This parameter can be accessed if:

- [LevelCtrl Strategy] L C S E is set to [Switches] E r A d, and
- [Nb Of Pumps] P P P n is higher than 1.

Identical to [Level Switch1 Assign] L c W 1 (see page 299).

### [Level Switch3 Assign] L c W 3 ★

Level switch 3 assignment.

This parameter can be accessed if:

- [LevelCtrl Strategy] L C S E is set to [Switches] E r A d, and
- [Nb Of Pumps] P P P n is higher than 2.

Identical to [Level Switch1 Assign] L c W 1 (see page 299).

**[Level Switch4 Assign] L c W 4 ★**

Level switch 4 assignment.

This parameter can be accessed if:

- **[LevelCtrl Strategy] L C 5 E** is set to **[Switches] E r H d**, and
- **[Nb Of Pumps] N P P n** is higher than 3.

Identical to **[Level Switch1 Assign] L c W 1** (see page 299).

**[Level Switch5 Assign] L c W 5 ★**

Level switch 5 assignment.

This parameter can be accessed if:

- **[LevelCtrl Strategy] L C 5 E** is set to **[Switches] E r H d**, and
- **[Nb Of Pumps] N P P n** is higher than 4.

Identical to **[Level Switch1 Assign] L c W 1** (see page 299).

**[Level Switch6 Assign] L c W 6 ★**

Level switch 6 assignment.

This parameter can be accessed if:

- **[LevelCtrl Strategy] L C 5 E** is set to **[Switches] E r H d**, and
- **[Nb Of Pumps] N P P n** is higher than 5.

Identical to **[Level Switch1 Assign] L c W 1** (see page 299).

**[Level 1st Pump Start] L r L I ★**

Level to start first pump.

This parameter can be accessed if:

- **[LevelCtrl Strategy] L C 5 E** is not set to **[Switches] E r H d**, and
- **[Nb Of Pumps] N P P n** is higher than 0.

Setting ( )	Description
0...100%	Setting range Factory setting: 0%

**[Level 1st Pump Stop] L P L I ★**

Level to stop first pump.

This parameter can be accessed if:

- **[LevelCtrl Strategy] L C 5 E** is not set to **[Switches] E r H d**, and
- **[Nb Of Pumps] N P P n** is higher than 0.

Setting ( )	Description
0...100%	Setting range Factory setting: 0%

**[Level 1st Pump at HSP] L h L I ★**

Level to reach first pump high speed.

This parameter can be accessed if:

- **[LevelCtrl Strategy] L C 5 E** is not set to **[Switches] E r H d**, and
- **[Nb Of Pumps] N P P n** is higher than 0.

Setting ( )	Description
0...100%	Setting range Factory setting: 0%

**[Level 2nd Pump Start] L r L 2 ★**

Level to start second pump.

This parameter can be accessed if:

- **[LevelCtrl Strategy] L C 5 E** is not set to **[Switches] E r A d**, and
- **[Nb Of Pumps] N P P n** is higher than 1.

Identical to **[Level 1st Pump Start] L r L 1** (*see page 300*).

**[Level 2nd Pump Stop] L P L 2 ★**

Level to stop second pump.

This parameter can be accessed if:

- **[LevelCtrl Strategy] L C 5 E** is not set to **[Switches] E r A d**, and
- **[Nb Of Pumps] N P P n** is higher than 1.

Identical to **[Level 1st Pump Start] L r L 1** (*see page 300*).

**[Level 2nd Pump at HSP] L h L 2 ★**

Level to reach second pump high speed.

This parameter can be accessed if:

- **[LevelCtrl Strategy] L C 5 E** is not set to **[Switches] E r A d**, and
- **[Nb Of Pumps] N P P n** is higher than 1.

Identical to **[Level 1st Pump Start] L r L 1** (*see page 300*).

**[Level 3rd Pump Start] L r L 3 ★**

Level to start third pump.

This parameter can be accessed if:

- **[LevelCtrl Strategy] L C 5 E** is not set to **[Switches] E r A d**, and
- **[Nb Of Pumps] N P P n** is higher than 2.

Identical to **[Level 1st Pump Start] L r L 1** (*see page 300*).

**[Level 3rd Pump Stop] L P L 3 ★**

Level to stop third pump.

This parameter can be accessed if:

- **[LevelCtrl Strategy] L C 5 E** is not set to **[Switches] E r A d**, and
- **[Nb Of Pumps] N P P n** is higher than 2.

Identical to **[Level 1st Pump Start] L r L 1** (*see page 300*).

**[Level 3rd Pump at HSP] L h L 3 ★**

Level to reach third pump high speed.

This parameter can be accessed if:

- **[LevelCtrl Strategy] L C 5 E** is not set to **[Switches] E r A d**, and
- **[Nb Of Pumps] N P P n** is higher than 2.

Identical to **[Level 1st Pump Start] L r L 1** (*see page 300*).

**[Level 4th Pump Start] L r L 4 ★**

Level to start fourth pump.

This parameter can be accessed if:

- **[LevelCtrl Strategy] L C 5 E** is not set to **[Switches] E r A d**, and
- **[Nb Of Pumps] N P P n** is higher than 3.

Identical to **[Level 1st Pump Start] L r L 1** (*see page 300*).

**[Level 4th Pump Stop] L P L 4 ★**

Level to stop fourth pump.

This parameter can be accessed if:

- **[LevelCtrl Strategy] L C 5 E** is not set to **[Switches] E r R d**, and
- **[Nb Of Pumps] N P P n** is higher than 3.

Identical to **[Level 1st Pump Start] L r L l** (*see page 300*).

**[Level 4th Pump at HSP] L h L 4 ★**

Level to reach fourth pump high speed.

This parameter can be accessed if:

- **[LevelCtrl Strategy] L C 5 E** is not set to **[Switches] E r R d**, and
- **[Nb Of Pumps] N P P n** is higher than 3.

Identical to **[Level 1st Pump Start] L r L l** (*see page 300*).

**[Level 5th Pump Start] L r L 5 ★**

Level to start fifth pump.

This parameter can be accessed if:

- **[LevelCtrl Strategy] L C 5 E** is not set to **[Switches] E r R d**, and
- **[Nb Of Pumps] N P P n** is higher than 4.

Identical to **[Level 1st Pump Start] L r L l** (*see page 300*).

**[Level 5th Pump Stop] L P L 5 ★**

Level to stop fifth pump.

This parameter can be accessed if:

- **[LevelCtrl Strategy] L C 5 E** is not set to **[Switches] E r R d**, and
- **[Nb Of Pumps] N P P n** is higher than 4.

Identical to **[Level 1st Pump Start] L r L l** (*see page 300*).

**[Level 5th Pump at HSP] L h L 5 ★**

Level to reach fifth pump high speed.

This parameter can be accessed if:

- **[LevelCtrl Strategy] L C 5 E** is not set to **[Switches] E r R d**, and
- **[Nb Of Pumps] N P P n** is higher than 4.

Identical to **[Level 1st Pump Start] L r L l** (*see page 300*).

**[Level 6th Pump Start] L r L 6 ★**

Level to start sixth pump.

This parameter can be accessed if:

- **[LevelCtrl Strategy] L C 5 E** is not set to **[Switches] E r R d**, and
- **[Nb Of Pumps] N P P n** is higher than 5.

Identical to **[Level 1st Pump Start] L r L l** (*see page 300*).

**[Level 6th Pump Stop] L P L 6 ★**

Level to stop sixth pump.

This parameter can be accessed if:

- **[LevelCtrl Strategy] L C 5 E** is not set to **[Switches] E r R d**, and
- **[Nb Of Pumps] N P P n** is higher than 5.

Identical to **[Level 1st Pump Start] L r L l** (*see page 300*).

**[Level 6th Pump at HSP] L h L 6 ★**

Level to reach sixth pump high speed.

This parameter can be accessed if:

- **[LevelCtrl Strategy] L C 5 E** is not set to **[Switches] E r A d**, and
- **[Nb Of Pumps] n P P n** is higher than 5.

Identical to **[Level 1st Pump Start] L r L 1** (*see page 300*).

---

## Section 7.9

### [Pump functions] - [PID controller]

---

#### What Is in This Section?

This section contains the following topics:

Topic	Page
[PID controller] $P, I, D$ - Overview	305
[Feedback] $F, D, B$ - Menu	308
[Reference frequency] $r, F$ - Menu	314
[PID preset references] $P, r, I$ - Menu	317
[Reference frequency] $r, F$ - Menu	319
[Settings] $S, E$ - Menu	320



## [PID controller] $P_{id}$ - Overview

### About This Menu

**NOTE:** This function cannot be used with some other functions. Follow the instructions about the compatibility of functions.

### Block Diagram

The function is activated by assigning an analog input to the PID feedback (measurement).

The PID feedback needs to be assigned to one of the analog inputs AI1 to AI5 or a pulse input, according to whether any I/O extension module has been inserted.

The PID reference needs to be assigned to the following parameters:

- Preset references via digital inputs ([Ref PID Preset 2]  $rP2$ , [Ref PID Preset 3]  $rP3$ , [Ref PID Preset 4]  $rP4$ ).
- In accordance with the configuration of [Intern PID Ref]  $rPi$ :
  - [Internal PID ref]  $rPi$ , or
  - Reference A [Ref Freq 1 Config]  $Fr1$  or [Ref.1B channel]  $Fr1b$ .

### Combination Table for Preset PID References:

DI ( $rP4$ )	DI ( $rP2$ )	$rP2 = na$	Reference
			$rPi$ or $Fr1(b)$
0	0		$rPi$ or $Fr1(b)$
0	1		$rP2$
1	0		$rP3$
1	1		$rP4$

A predictive speed reference can be used to initialize the speed on restarting the process.

Scaling of feedback and references:

- [Min PID feedback]  $P_{F1}$ , [Max PID feedback]  $P_{F2}$  parameters can be used to scale the PID feedback (sensor range). **This scale MUST be maintained for all other parameters.**
- [Min PID Process]  $P_{P1}$ , [Max PID Process]  $P_{P2}$  parameters can be used to scale the adjustment range, for example the reference. **Check that the adjustment range remains within the sensor range.**

The maximum value of the scaling parameters is 32,767. To facilitate the installation, it is recommended to use values as close as possible to this maximum level, while retaining powers of 10 in relation to the actual values. The scaling is without unit if [Type of control]  $EkLk$  is set to [NA]  $nA$ , in % if set to [OTHER]  $okHEr$ , in process unit if set to [PRESSURE]  $PRES55$  or [FLOW]  $FLow$ .

### Example

Adjustment of the volume in a tank, 6...15 m<sup>3</sup>.

- Probe used 4-20 mA, 4.5 m<sup>3</sup> for 4 mA and 20 m<sup>3</sup> for 20 mA, with the result that  $P_{F1} = 4,500$  and  $P_{F2} = 20,000$ .
- Adjustment range 6 to 15 m<sup>3</sup>, with the result that  $P_{P1} = 6,000$  (min. reference) and  $P_{P2} = 15,000$  (max. reference).
- Example references:
  - $rP1$  (internal reference) = 9,500
  - $rP2$  (preset reference) = 6,500
  - $rP3$  (preset reference) = 8,000
  - $rP4$  (preset reference) = 11,200

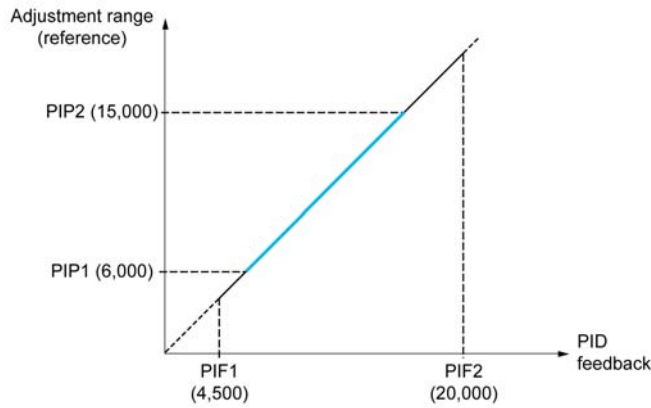

Other parameters:

- Reversal of the direction of correction **[PID Inversion] P, C**. If **[PID Inversion] P, C** is set to **[No] n o**, the speed of the motor increases when the detected error is positive (for example pressure control with a compressor). If **[PID Inversion] P, C** is set to **[Yes] y e s**, the speed of the motor decreases when the detected error is positive (for example temperature control using a cooling fan).
- The integral gain may be short-circuited by a digital input.
- A warning on the **[PID feedback] P, F** may be configured.
- A warning on the **[PID error] r P E** may be configured.

**"Manual - Automatic" Operation with PID**

This function combines the PID controller, the preset speeds, and a manual reference. Depending on the state of the digital input, the speed reference is given by the preset speeds or by a manual reference input via the PID function.

Manual PID reference **[Manual PID reference] P, Π**:

- Analog inputs AI1 to AI5
- Pulse inputs

Predictive speed reference **[Predictive Speed Ref] F P, ι**:

- **[AI1] A, 1**: analog input
- **[AI2] A, 2**: analog input
- **[AI3] A, 3**: analog input
- **[AI4] A, 4**: analog input
- **[AI5] A, 5**: analog input
- **[DI5 PulseInput Assignment] P, 5**: pulse input
- **[DI6 PulseInput Assignment] P, 6**: pulse input
- **[Ref.Freq-Rmt.Term] L C C**: Graphic Display Terminal
- **[Modbus] Π d b**: integrated Modbus
- **[CANopen] C A n**: CANopen®
- **[Com. Module] n E E**: fieldbus option module (if inserted)
- **[Embedded Ethernet] E E H**: integrated Ethernet Modbus TCP

**Setting Up the PID Controller**

**1. Configuration in PID mode.**

Refer to the Block Diagram (see page 305).

**2. Perform a test in factory settings mode.**

To optimize the drive, adjust **[PID Prop.Gain] r P G** or **[PID Intgl.Gain] r, G** gradually and independently, and observe the effect on the PID feedback in relation to the reference.

**3. If the factory settings are unstable or the reference is incorrect.**

Step	Action
1	Perform a test with a speed reference in Manual mode (without PID controller) and with the drive on load for the speed range of the system: <ul style="list-style-type: none"> <li>• In steady state, the speed must be stable and comply with the reference, and the PID feedback signal must be stable.</li> <li>• In transient state, the speed must follow the ramp and stabilize quickly, and the PID feedback must follow the speed. If not, see the settings for the drive and/or sensor signal and wiring.</li> </ul>

Step	Action
2	Switch to PID mode.
3	Set <b>[PID ramp] <math>P_r P</math></b> to the minimum permitted by the mechanism without triggering an <b>[DC Bus Overvoltage] <math>o b F</math></b> .
4	Set the integral gain <b>[PID Intgl.Gain] <math>r_i G</math></b> to minimum.
5	Leave the derivative gain <b>[PID derivative gain] <math>r_d G</math></b> at 0.
6	Observe the PID feedback and the reference.
7	Switch the drive ON/OFF a number of times or vary the load or reference rapidly a number of times.
8	Set the proportional gain <b>[PID Prop.Gain] <math>r_P G</math></b> in order to ascertain the compromise between response time and stability in transient phases (slight overshoot and 1 to 2 oscillations before stabilizing).
9	If the reference varies from the preset value in steady state, gradually increase the integral gain <b>[PID Intgl.Gain] <math>r_i G</math></b> , reduce the proportional gain <b>[PID Prop.Gain] <math>r_P G</math></b> in the event of instability (pump applications), find a compromise between response time and static precision (see diagram).
10	Lastly, the derivative gain may permit the overshoot to be reduced and the response time to be improved, although this is more difficult to obtain a compromise in terms of stability, as it depends on 3 gains.
11	Perform in-production tests over the whole reference range.

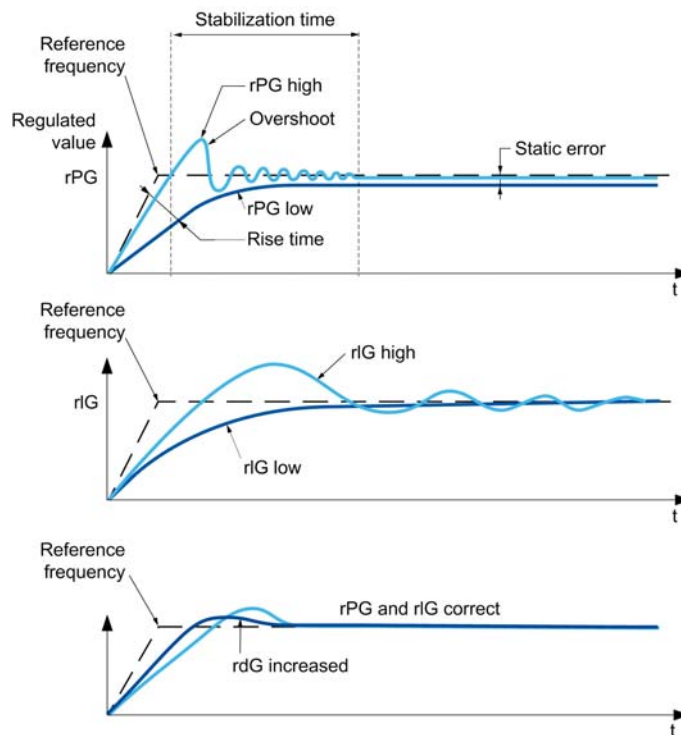

The oscillation frequency depends on the system kinematics:

Parameter	Rise time	Overshoot	Stabilization time	Static Error
rPG +	- -	+	=	-
rIG +	-	++	+	- -
rdG +	=	-	-	=

**[Feedback] F d b - Menu****Access**

[Complete settings] → [Pump functions] → [PID controller] → [Feedback]

**About This Menu**

**NOTE:** This function cannot be used with some other functions. Follow the instructions about the compatibility of functions.

**[Type of Control] t o c t**

Type of control for the PID = unit choice.

Setting	Code / Value	Description
[nA]	n A	(without unit) <b>Factory setting</b>
[Pressure]	P	Pressure control and unit
[Flow]	F	Flow control and unit
[Other]	o	Other control and unit (%)

**[PID Feedback] P , F**

PID controller feedback.

Setting	Code / Value	Description
[No]	n o	Not assigned <b>Factory setting</b>
[AI1]...[AI3]	A , 1... A , 3	Analog input AI1...AI3
[AI4]...[AI5]	A , 4... A , 5	Analog input AI4...AI5 if VW3A3203 I/O extension module has been inserted
[AI Virtual 1]	A , v 1	Virtual analogic input 1
[PulseInput Assignment On DI5]...[PulseInput Assignment On DI6]	P , 5... P , 6	Digital input DI5...DI6 used as pulse input

**[AI1 Type] A , t ★**

Configuration of analog input AI1.

This parameter can be accessed if [PID Feedback] P , F is set to [AI1] A , 1.

Setting	Code / Value	Description
[Voltage]	l 0 v	0-10 Vdc <b>Factory setting</b>
[Current]	0 A	0-20 mA

**[AI1 min value] v , l / ★**

AI1 voltage scaling parameter of 0%.

This parameter can be accessed if:

- [PID Feedback] P , F is set to [AI1] A , 1, and
- [AI1 Type] A , t is not set to [Voltage] l 0 v.

Setting	Description
0.0...10.0 Vdc	Setting range <b>Factory setting:</b> 0.0 Vdc

**[AI1 max value]  $\cup, H, I$  ★**

AI1 voltage scaling parameter of 100%.

This parameter can be accessed if:

- **[PID Feedback]  $P, F$**  is set to **[AI1]  $R, I$** , and
- **[AI1 Type]  $R, I, E$**  is not set to **[Voltage]  $ID \cup$** .

Setting	Description
0.0...10.0 Vdc	Setting range <b>Factory setting:</b> 10.0 Vdc

**[AI1 min. value]  $C, R, L, I$  ★**

AI1 current scaling parameter of 0%.

This parameter can be accessed if:

- **[PID Feedback]  $P, F$**  is set to **[AI1]  $R, I$** , and
- **[AI1 Type]  $R, I, E$**  is not set to **[Current]  $DR$** .

Setting	Description
0.0...20.0 mA	Setting range <b>Factory setting:</b> 0.0 mA

**[AI1 max. value]  $C, R, H, I$  ★**

AI1 current scaling parameter of 100%.

This parameter can be accessed if:

- **[PID Feedback]  $P, F$**  is set to **[AI1]  $R, I$** , and
- **[AI1 Type]  $R, I, E$**  is not set to **[Current]  $DR$** .

Setting	Description
0.0...20.0 mA	Setting range <b>Factory setting:</b> 20.0 mA

**[AI2 Type]  $R, I, 2, E$  ★**

Configuration of analog input AI2.

This parameter can be accessed if **[PID Feedback]  $P, F$**  is set to **[AI2]  $R, I, 2$** .

Setting	Code / Value	Description
<b>[Voltage]</b>	$ID \cup$	0-10 Vdc <b>Factory setting</b>
<b>[Current]</b>	$DR$	0-20 mA
<b>[PTC Management]</b>	$P, E, C$	1 to 6 PTC (in serial)
<b>[KTY]</b>	$K, E, Y$	1 KTY84
<b>[PT1000]</b>	$I, P, E, 3$	1 PT1000 connected with 2 wires
<b>[PT100]</b>	$I, P, E, 2$	1 PT100 connected with 2 wires
<b>[Water Prob]</b>	$L, E, \cup, E, L$	Water level
<b>[3PT1000]</b>	$3, P, E, 3$	3 PT1000 connected with 2 wires
<b>[3PT100]</b>	$3, P, E, 2$	3 PT100 connected with 2 wires

**[AI2 min value]  $\cup, I, L, 2$  ★**

AI2 voltage scaling parameter of 0%.

This parameter can be accessed if:

- **[PID Feedback]  $P, F$**  is set to **[AI2]  $R, I, 2$** , and
- **[AI2 Type]  $R, I, 2, E$**  is not set to **[Voltage]  $ID \cup$** .

Identical to **[AI1 min value]  $\cup, I, L, I$**  (see page 308).

**[AI2 max value]  $\mu, H 2$  ★**

AI2 voltage scaling parameter of 100%.

This parameter can be accessed if:

- **[PID Feedback]  $P, F$**  is set to **[AI2]  $A, 2$** , and
- **[AI2 Type]  $A, 2 E$**  is not set to **[Voltage]  $10 \mu$** .

Identical to **[AI1 max value]  $\mu, H 1$**  (see page 309).

**[AI2 min. value]  $C, L 2$  ★**

AI2 current scaling parameter of 0%.

This parameter can be accessed if:

- **[PID Feedback]  $P, F$**  is set to **[AI2]  $A, 2$** , and
- **[AI2 Type]  $A, 2 E$**  is not set to **[Current]  $0 A$** .

Identical to **[AI1 min. value]  $C, L 1$**  (see page 309).

**[AI2 max. value]  $C, H 2$  ★**

AI2 current scaling parameter of 100%.

This parameter can be accessed if:

- **[PID Feedback]  $P, F$**  is set to **[AI2]  $A, 2$** , and
- **[AI2 Type]  $A, 2 E$**  is not set to **[Current]  $0 A$** .

Identical to **[AI1 max. value]  $C, H 1$**  (see page 309).

**[AI3 Type]  $A, 3 E$  ★**

Configuration of analog input AI3.

This parameter can be accessed if **[PID Feedback]  $P, F$**  is set to **[AI3]  $A, 3$** .

Identical to **[AI2 Type]  $A, 2 E$**  with factory setting: **[Current]  $0 A$**  (see page 309).

**[AI3 min value]  $\mu, L 3$  ★**

AI3 voltage scaling parameter of 0%.

This parameter can be accessed if:

- **[PID Feedback]  $P, F$**  is set to **[AI3]  $A, 3$** , and
- **[AI3 Type]  $A, 3 E$**  is not set to **[Voltage]  $10 \mu$** .

Identical to **[AI1 min value]  $\mu, L 1$**  (see page 308).

**[AI3 max value]  $\mu, H 3$  ★**

AI3 voltage scaling parameter of 100%.

This parameter can be accessed if:

- **[PID Feedback]  $P, F$**  is set to **[AI3]  $A, 3$** , and
- **[AI3 Type]  $A, 3 E$**  is not set to **[Voltage]  $10 \mu$** .

Identical to **[AI1 max value]  $\mu, H 1$**  (see page 309).

**[AI3 min. value]  $C, L 3$  ★**

AI3 current scaling parameter of 0%.

This parameter can be accessed if:

- **[PID Feedback]  $P, F$**  is set to **[AI3]  $A, 3$** , and
- **[AI3 Type]  $A, 3 E$**  is not set to **[Current]  $0 A$** .

Identical to **[AI1 min. value]  $C, L 1$**  (see page 309).

**[AI3 max. value] C r H 3 ★**

AI3 current scaling parameter of 100%.

This parameter can be accessed if:

- **[PID Feedback] P , F** is set to **[AI3] R , 3**, and
- **[AI3 Type] R , 3 E** is not set to **[Current] D R**.

Identical to **[AI1 max. value] C r H 1** (see page 309).

**[AI4 Type] R , 4 E ★**

Configuration of analog input AI4.

This parameter can be accessed if:

- VW3A3203 I/O extension module has been inserted, and
- **[PID Feedback] P , F** is set to **[AI4] R , 4**.

Setting	Code / Value	Description
<b>[Voltage]</b>	<b>1 0 u</b>	0-10 Vdc
<b>[Current]</b>	<b>D R</b>	0-20 mA
<b>[Voltage +/-]</b>	<b>n 1 0 u</b>	-10/+10 Vdc <b>Factory setting</b>
<b>[PTC Management]</b>	<b>P E C</b>	1 to 6 PTC (in serial)
<b>[KTY]</b>	<b>K E Y</b>	1 KTY84
<b>[PT1000]</b>	<b>1 P E 3</b>	1 PT1000 connected with 2 wires
<b>[PT100]</b>	<b>1 P E 2</b>	1 PT100 connected with 2 wires
<b>[3 PT1000]</b>	<b>3 P E 3</b>	3 PT1000 connected with 2 wires
<b>[3 PT100]</b>	<b>3 P E 2</b>	3 PT100 connected with 2 wires
<b>[PT1000 in 3 wires]</b>	<b>1 P E 3 3</b>	1 PT1000 connected with 3 wires (AI4 & AI5 only)
<b>[PT100 in 3 wires]</b>	<b>1 P E 2 3</b>	1 PT100 connected with 3 wires (AI4 & AI5 only)
<b>[3 PT1000 in 3 wires]</b>	<b>3 P E 3 3</b>	3 PT1000 connected with 3 wires (AI4 & AI5 only)
<b>[3 PT100 in 3 wires]</b>	<b>3 P E 2 3</b>	3 PT100 connected with 3 wires (AI4 & AI5 only)

**[AI4 min value] u , L 4 ★**

AI4 voltage scaling parameter of 0%.

This parameter can be accessed if:

- **[PID Feedback] P , F** is set to **[AI4] R , 4**, and
- **[AI4 Type] R , 4 E** is not set to **[Voltage] 1 0 u**.

Identical to **[AI1 min value] u , L 1** (see page 308).

**[AI4 max value] u , H 4 ★**

AI4 voltage scaling parameter of 100%.

This parameter can be accessed if:

- **[PID Feedback] P , F** is set to **[AI4] R , 4**, and
- **[AI4 Type] R , 4 E** is not set to **[Voltage] 1 0 u**.

Identical to **[AI1 max value] u , H 1** (see page 309).

**[AI4 min. value] C r L 4 ★**

AI4 current scaling parameter of 0%.

This parameter can be accessed if:

- **[PID Feedback] P , F** is set to **[AI4] R , 4**, and
- **[AI4 Type] R , 4 E** is not set to **[Current] D R**.

Identical to **[AI1 min. value] C r L 1** (see page 309).

**[AI4 max. value] C r H 4 ★**

AI4 current scaling parameter of 100%.

This parameter can be accessed if:

- **[PID Feedback] P , F** is set to **[AI4] R , 4**, and
- **[AI4 Type] R , 4 E** is not set to **[Current] D R**.

Identical to **[AI1 max. value] C r H 1** (see page 309).

**[AI5 Type] R , 5 E ★**

Configuration of analog input AI5.

This parameter can be accessed if:

- VW3A3203 I/O extension module has been inserted, and
- **[PID Feedback] P , F** is set to **[AI5] R , 5**.

Identical to **[AI4 Type] R , 4 E** (see page 311).

**[AI5 min value] u , L 5 ★**

AI5 voltage scaling parameter of 0%.

This parameter can be accessed if:

- **[PID Feedback] P , F** is set to **[AI5] R , 5**, and
- **[AI5 Type] R , 5 E** is not set to **[Voltage] I D u**.

Identical to **[AI1 min value] u , L 1** (see page 308).

**[AI5 max value] u , H 5 ★**

AI5 voltage scaling parameter of 100%.

This parameter can be accessed if:

- **[PID Feedback] P , F** is set to **[AI5] R , 5**, and
- **[AI5 Type] R , 5 E** is not set to **[Voltage] I D u**.

Identical to **[AI1 max value] u , H 1** (see page 309).

**[AI5 min. value] C r L 5 ★**

AI5 current scaling parameter of 0%.

This parameter can be accessed if:

- **[PID Feedback] P , F** is set to **[AI5] R , 5**, and
- **[AI5 Type] R , 5 E** is not set to **[Current] D R**.

Identical to **[AI1 min. value] C r L 1** (see page 309).

**[AI5 max. value] C r H 5 ★**

AI5 current scaling parameter of 100%.

This parameter can be accessed if:

- **[PID Feedback] P , F** is set to **[AI5] R , 5**, and
- **[AI5 Type] R , 5 E** is not set to **[Current] D R**.

Identical to **[AI1 max. value] C r H 1** (see page 309).

**[Min PID feedback] P , F 1 ★**

Minimum PID feedback.

This parameter can be accessed if **[PID Feedback] P , F** is not set to **[No] n o**.

Setting ( )	Description
0... <b>[Max PID feedback] P , F 2</b>	Setting range Factory setting: 100



**[Max PID feedback] P , F 2 ★**

Maximum PID feedback.

This parameter can be accessed if **[PID Feedback] P , F** is not set to **[No] n o .**

Setting ( )	Description
<b>[Min PID feedback] P , F 1</b> ...32,767	Setting range <b>Factory setting:</b> 1,000

**[PID feedback] r P F ★**

Value for PID feedback, display only.

This parameter can be accessed if **[PID Feedback] P , F** is not set to **[No] n o .**

Setting	Description
0...65,535	Setting range <b>Factory setting:</b> _

**[Min Fbk Warning] P A L ★**

Minimum feedback level warning.

This parameter can be accessed if **[PID Feedback] P , F** is not set to **[No] n o .**

Setting ( )	Description
0...65,535	Setting range <b>Factory setting:</b> 100

**[Max Fbk Warning] P A H ★**

Maximum feedback level warning.

This parameter can be accessed if **[PID Feedback] P , F** is not set to **[No] n o .**

Setting ( )	Description
0...65,535	Setting range <b>Factory setting:</b> 1,000

## [Reference frequency] $r F$ - Menu

### Access

[Complete settings] → [Pump functions] → [PID controller] → [Reference frequency]

### About This Menu

**NOTE:** This function cannot be used with some other functions. Follow the instructions about the compatibility of functions.

### [Intern PID Ref] $P_{II}$ ★

Internal PID controller reference.

This parameter can be accessed if [PID Feedback]  $P_{IF}$  is not set to [Not Configured]  $n o$ .

Setting	Code / Value	Description
[No]	$n o$	The PID controller reference is given by [Ref Freq 1 Config] $F_{r1}$ or [Ref.1B channel] $F_{r1b}$ with summing/subtraction/multiplication functions. Refer to the block diagram ( <a href="#">see page 305</a> ). <b>Factory setting</b>
[Yes]	$y e s$	The PID controller reference is internal via [Internal PID ref] $r P_{II}$ .

### [Ref Freq 1 Config] $F_{r1}$ ★

Configuration reference frequency 1.

This parameter can be accessed if:

- [PID Feedback]  $P_{IF}$  is not set to [Not Configured]  $n o$ , and
- [Intern PID Ref]  $P_{II}$  is set to [No]  $n o$ .

Setting	Code / Value	Description
[Not Configured]	$n o$	Not assigned
[AI1]	$A_{I1}$	Analog input AI1 <b>Factory Setting</b>
[AI2]...[AI3]	$A_{I2}...A_{I3}$	Analog input AI2...AI3
[AI4]...[AI5]	$A_{I4}...A_{I5}$	Analog input AI4...AI5 if VW3A3203 I/O extension module has been inserted
[Ref Frequency via DI]	$u P d t$	Up/Down function is assigned by DIx
[Ref. Freq-Modbus]	$M o d b$	Reference frequency via Modbus
[Ref. Freq-CANopen]	$C A n$	Reference frequency via CANopen if a CANopen module has been inserted
[Ref. Freq-Com. Module]	$n e t$	Reference frequency via fieldbus module if a fieldbus module has been inserted
[Embedded Ethernet]	$E t H$	Embedded Ethernet
[PulseInput Assignment On DI5]...[PulseInput Assignment On DI6]	$P_{I5}...P_{I6}$	Digital input DI5...DI6 used as pulse input

### [Min PID reference] $P_{IP1}$ ★

Minimum PID reference.

This parameter can be accessed if [PID Feedback]  $P_{IF}$  is not set to [Not Configured]  $n o$ .

Setting ( )	Description
[Min PID feedback] $P_{IP1}$ ... [Max PID reference] $P_{IP2}$	Setting range <b>Factory setting:</b> 150

**[Max PID reference] P , P 2 ★**

Maximum PID reference.

This parameter can be accessed if **[PID Feedback] P , F** is not set to **[Not Configured] n o**.

Setting ( )	Description
<b>[Min PID reference] P , P 1</b> ... <b>[Max PID feedback] P , F 2</b>	Setting range <b>Factory setting:</b> 900

**[Internal PID ref] r P , ★**

Internal PID controller reference.

This parameter can be accessed if:

- **[PID Feedback] P , F** is not set to **[Not Configured] n o**, and
- **[Intern PID Ref] P , r** is set to **[Yes] Y E 5**.

Setting ( )	Description
<b>[Min PID reference] P , P 1</b> ... <b>[Max PID reference] P , P 2</b>	Setting range <b>Factory setting:</b> 150

**[Auto/Manual assign.] P A u ★**

Auto/Manual select input.

This parameter can be accessed if **[PID Feedback] P , F** is not set to **[Not Configured] n o**.

Setting	Code / Value	Description
<b>[Not Assigned]</b>	n o	Not assigned <b>Factory setting</b>
<b>[DI1]...[DI6]</b>	L , l ... L , l 6	Digital input DI1...DI6
<b>[DI11]...[DI16]</b>	L , l l l ... L , l l 6	Digital input DI11...DI16 if VW3A3203 I/O extension module has been inserted
<b>[CD00]...[CD10]</b>	C d 0 0 ... C d 1 0	Virtual digital input CMD.0...CMD.10 in <b>[I/O profile] , o</b> configuration
<b>[CD11]...[CD15]</b>	C d 1 1 ... C d 1 5	Virtual digital input CMD.11...CMD.15 regardless of configuration
<b>[C100]...[C110]</b>	C 1 0 0 ... C 1 1 0	Virtual digital input CMD1.0...CMD1.10 with integrated Modbus Serial in <b>[I/O profile] , o</b> configuration
<b>[C111]...[C115]</b>	C 1 1 1 ... C 1 1 5	Virtual digital input CMD1.11...CMD1.15 with integrated Modbus Serial regardless of configuration
<b>[C200]...[C210]</b>	C 2 0 0 ... C 2 1 0	Virtual digital input CMD2.0...CMD2.10 with CANopen® fieldbus module in <b>[I/O profile] , o</b> configuration
<b>[C211]...[C215]</b>	C 2 1 1 ... C 2 1 5	Virtual digital input CMD2.11...CMD2.15 with CANopen® fieldbus module regardless of configuration
<b>[C300]...[C310]</b>	C 3 0 0 ... C 3 1 0	Virtual digital input CMD3.0...CMD3.10 with a fieldbus module in <b>[I/O profile] , o</b> configuration
<b>[C311]...[C315]</b>	C 3 1 1 ... C 3 1 5	Virtual digital input CMD3.11...CMD3.15 with a fieldbus module regardless of configuration
<b>[C500]...[C510]</b>	C 5 0 0 ... C 5 1 0	Virtual digital input CMD5.0...CMD5.10 with integrated Ethernet Modbus TCP in <b>[I/O profile] , o</b> configuration
<b>[C511]...[C515]</b>	C 5 1 1 ... C 5 1 5	Virtual digital input CMD5.11...CMD5.15 with integrated Ethernet Modbus TCP regardless of configuration

**[Manual PID Reference] P , n ★**

Manual PID reference.

Reference input in manual mode.

This parameter can be accessed if:

- **[PID Feedback] P , F** is not set to **[Not Configured] n o**, and
- **[Auto/Manual assign.] P A u** is not set to **[No] n o**.

The preset speeds are active on the manual reference if they have been configured.

Setting	Code / Value	Description
[No]	<i>n a</i>	Not assigned <b>Factory setting</b>
[AI1]...[AI3]	<i>R , 1...R , 3</i>	Analog input AI1...AI3
[AI4]...[AI5]	<i>R , 4...R , 5</i>	Analog input AI4...AI5 if VW3A3203 I/O extension module has been inserted
[Ref.Freq-Rmt.Term]	<i>L C C</i>	Display terminal source
[Ref. Freq-Modbus]	<i>Π d b</i>	Reference frequency via Modbus
[Ref. Freq- CANopen]	<i>C R n</i>	Reference frequency via CANopen
[Ref. Freq-Com. Module]	<i>n E E</i>	Reference frequency via COM module
[Embedded Ethernet]	<i>E E H</i>	Embedded Ethernet source
[PulseInput Assignment On DI5]...[PulseInput Assignment On DI6]	<i>P , 5...P , 6</i>	Digital input DI5...DI6 used as pulse input

## [PID preset references] $P_{r1}$ - Menu

### Access

[Complete settings] → [Pump functions] → [PID controller] → [Reference frequency] → [PID preset references]

### About This Menu

The function can be accessed if [PID feedback ass.]  $P_{r1F}$  is assigned.

### [2 PID Preset Assign] $P_{r2}$

2 PID preset assignment.

If the assigned input or bit is at 0, the function is inactive.

If the assigned input or bit is at 1, the function is active.

Setting	Code / Value	Description
[Not Assigned]	$n a$	Not assigned <b>Factory setting</b>
[DI1]...[DI6]	$L 1 L 6$	Digital input DI1...DI6
[DI11]...[DI16]	$L 11 L 16$	Digital input DI11...DI16 if VW3A3203 I/O extension module has been inserted
[CD00]...[CD10]	$C d 00 C d 10$	Virtual digital input CMD.0...CMD.10 in [I/O profile] $i a$ configuration
[CD11]...[CD15]	$C d 11 C d 15$	Virtual digital input CMD.11...CMD.15 regardless of configuration
[C100]...[C110]	$C 100 C 110$	Virtual digital input CMD1.0...CMD1.10 with integrated Modbus Serial in [I/O profile] $i a$ configuration
[C111]...[C115]	$C 111 C 115$	Virtual digital input CMD1.11...CMD1.15 with integrated Modbus Serial regardless of configuration
[C200]...[C210]	$C 200 C 210$	Virtual digital input CMD2.0...CMD2.10 with CANopen® fieldbus module in [I/O profile] $i a$ configuration
[C211]...[C215]	$C 211 C 215$	Virtual digital input CMD2.11...CMD2.15 with CANopen® fieldbus module regardless of configuration
[C300]...[C310]	$C 300 C 310$	Virtual digital input CMD3.0...CMD3.10 with a fieldbus module in [I/O profile] $i a$ configuration
[C311]...[C315]	$C 311 C 315$	Virtual digital input CMD3.11...CMD3.15 with a fieldbus module regardless of configuration
[C500]...[C510]	$C 500 C 510$	Virtual digital input CMD5.0...CMD5.10 with integrated Ethernet Modbus TCP in [I/O profile] $i a$ configuration
[C511]...[C515]	$C 511 C 515$	Virtual digital input CMD5.11...CMD5.15 with integrated Ethernet Modbus TCP regardless of configuration
[DI1 (Low level)]...[DI6 (Low level)]	$L 1 L 6 L$	Digital input DI1...DI6 used at low level
[DI11 (Low level)]...[DI16 (Low level)]	$L 11 L 16 L$	Digital input DI11...DI16 used at low level if VW3A3203 I/O extension module has been inserted

### [4 PID Preset Assign] $P_{r4}$

4 PID preset assignment.

Identical to [2 PID Preset Assign]  $P_{r2}$  (see page 317).

Verify that [2 PID Preset Assign]  $P_{r2}$  has been assigned before assigning this function.

**[Ref PID Preset 2] *r P 2* ★**

Second PID preset reference.

This parameter can be accessed only if **[2 PID Preset Assign] *P r 2*** is assigned.

Setting ( )	Description
<b>[Min PID reference] <i>P , P 1</i>...[Max PID reference] <i>P , P 2</i></b>	Setting range <b>Factory setting:</b> 300

**[Ref PID Preset 3] *r P 3* ★**

Third PID preset reference.

This parameter can be accessed only if **[4 preset PID ref.] *P r 4*** is assigned.

Setting ( )	Description
<b>[Min PID reference] <i>P , P 1</i>...[Max PID reference] <i>P , P 2</i></b>	Setting range <b>Factory setting:</b> 600

**[Ref PID Preset 4] *r P 4* ★**

Fourth PID preset reference.

This parameter can be accessed only if **[2 preset PID ref.] *P r 2*** and **[4 preset PID ref.] *P r 4*** are assigned.

Setting ( )	Description
<b>[Min PID reference] <i>P , P 1</i>...[Max PID reference] <i>P , P 2</i></b>	Setting range <b>Factory setting:</b> 900

## [Reference frequency] $r F$ - Menu

### Access

[Complete settings] → [Pump functions] → [PID controller] → [Reference frequency]

### [Predictive Speed Ref] $F P$ , ★

Predictive speed reference.

This parameter can be accessed if [Access Level]  $L R C$  is set to [Expert]  $E P r$ .

Setting	Code / Value	Description
[No]	$n o$	Not assigned <b>Factory setting</b>
[AI1]...[AI3]	$A , 1 \dots A , 3$	Analog input AI1...AI3
[AI4]...[AI5]	$A , 4 \dots A , 5$	Analog input AI4...AI5 if VW3A3203 I/O extension module has been inserted
[Ref. Freq- Rmt.Term]	$L C C$	Reference frequency via remote terminal
[Ref. Freq-Modbus]	$M o d b$	Reference frequency via Modbus
[Ref. Freq-CANopen]	$C A n$	Reference frequency via CANopen
[Ref. Freq-Com. Module]	$n E t$	Reference frequency via communication module
[Embedded Ethernet]	$E t H$	Embedded Ethernet
[PulseInput Assignment On DI5]...[PulseInput Assignment On DI6]	$P , 5 \dots P , 6$	Digital input DI5...DI6 used as pulse input

### [Speed Input %] $P S r$ ★

PID speed input % reference.

This parameter can be accessed if [Access Level]  $L R C$  is set to [Expert]  $E P r$ .

Setting ( )	Description
1...100%	Setting range <b>Factory setting:</b> 100%

## [Settings] 5 L - Menu

### Access

[Complete settings] → [Pump functions] → [PID controller] → [Settings]

### About This Menu

Following parameters can be accessed if [PID Feedback]  $P, F$  is not set to [Not Configured]  $n o$ .

**NOTE:** This function cannot be used with some other functions. Follow the instructions about the compatibility of functions.

### [PID Prop.Gain] $r P G$ ★

Proportional gain.

Setting ( )	Description
0.01...100.00	Setting range <b>Factory setting:</b> 1.00

### [PI Intgl.Gain] $r I G$ ★

Integral gain.

Setting ( )	Description
0.01...100.00	Setting range <b>Factory setting:</b> 1.00

### [PID derivative gain] $r d G$ ★

Derivative gain.

Setting ( )	Description
0.00...100.00	Setting range <b>Factory setting:</b> 0.00

### [PID ramp] $P r P$ ★

PID acceleration/deceleration ramp, defined to go from [Min PID reference]  $P, P 1$  to [Max PID reference]  $P, P 2$  and conversely.

Setting ( )	Description
0.0...99.9 s	Setting range <b>Factory setting:</b> 0.0 s

### [PID Inversion] $P, I$ ★

PID inversion.

Setting	Code / Value	Description
[No]	$n o$	No <b>Factory setting</b>
[YES]	$y e s$	Yes



**[PID Min Output] P o L ★**

PID controller minimum output in Hz.

Setting ( )	Description
0.0...500.0 Hz	Setting range <b>Factory setting:</b> 0.0 Hz

**[PID Max Output] P o H ★**

PID controller maximum output in Hz.

Setting ( )	Description
0.0...500.0 Hz	Setting range <b>Factory setting:</b> 60.0 Hz

**[PID Error Warning] P E r ★**

PID error warning.

Setting ( )	Description
0...65,535	Setting range <b>Factory setting:</b> 100

**[PID Integral OFF] P , 5 ★**

Integral shunt.

If the assigned input or bit is at 0, the function is inactive (the PID integral is enabled).

If the assigned input or bit is at 1, the function is active (the PID integral is disabled).

Setting	Code / Value	Description
[Not Assigned]	n o	Not assigned <b>Factory setting</b>
[DI1]...[DI6]	L , 1...L , 6	Digital input DI1...DI6
[DI11]...[DI16]	L , 11...L , 16	Digital input DI11...DI16 if VW3A3203 I/O extension module has been inserted
[CD00]...[CD10]	C d 0 0...C d 1 0	Virtual digital input CMD.0...CMD.10 in <b>[I/O profile]</b> , o configuration
[CD11]...[CD15]	C d 1 1...C d 1 5	Virtual digital input CMD.11...CMD.15 regardless of configuration
[C100]...[C110]	C 1 0 0...C 1 1 0	Virtual digital input CMD1.0...CMD1.10 with integrated Modbus Serial in <b>[I/O profile]</b> , o configuration
[C111]...[C115]	C 1 1 1...C 1 1 5	Virtual digital input CMD1.11...CMD1.15 with integrated Modbus Serial regardless of configuration
[C200]...[C210]	C 2 0 0...C 2 1 0	Virtual digital input CMD2.0...CMD2.10 with CANopen® fieldbus module in <b>[I/O profile]</b> , o configuration
[C211]...[C215]	C 2 1 1...C 2 1 5	Virtual digital input CMD2.11...CMD2.15 with CANopen® fieldbus module regardless of configuration
[C300]...[C310]	C 3 0 0...C 3 1 0	Virtual digital input CMD3.0...CMD3.10 with a fieldbus module in <b>[I/O profile]</b> , o configuration
[C311]...[C315]	C 3 1 1...C 3 1 5	Virtual digital input CMD3.11...CMD3.15 with a fieldbus module regardless of configuration
[C500]...[C510]	C 5 0 0...C 5 1 0	Virtual digital input CMD5.0...CMD5.10 with integrated Ethernet Modbus TCP in <b>[I/O profile]</b> , o configuration
[C511]...[C515]	C 5 1 1...C 5 1 5	Virtual digital input CMD5.11...CMD5.15 with integrated Ethernet Modbus TCP regardless of configuration

**[PID acceleration time] ACCP ★**

PID: acceleration during start-up.

PID start ramp can be applied before starting the PID controller to allow reaching quickly the PID reference without increasing PID gains. If configured, the **[Start Accel Ramp] ACC5** is applied up to **[Low Speed] L5P** instead of **[PID acceleration time] ACCP**.

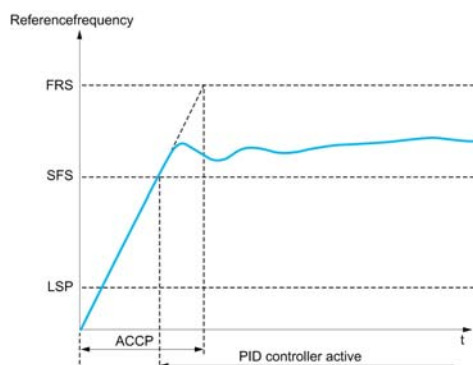

Setting ( )	Description
0.01...99,99 s <sup>(1)</sup>	Setting range <b>Factory setting:</b> 0.50 s
1	Range 0.01 to 99.99 s or 0.1 to 999.9 s or 1...6,000 s according to <b>[Ramp increment] INC</b> .

**[PID Start Ref Freq] SF5 ★**

PID: speed reference for start-up.

Setting ( )	Description
0.0...500.0 Hz	Setting range If <b>[PID Start Ref Freq] SF5</b> is lower than <b>[Low speed] L5P</b> , this function has no effect. <b>Factory setting:</b> 0.0 Hz

## Section 7.10

### [Pump functions] - [Sleep/wakeup]

#### What Is in This Section?

This section contains the following topics:

Topic	Page
[Sleep/Wakeup] <i>S P W</i> - Overview	324
[Sleep menu] <i>S L P</i> - Menu	327
[AI1 Sensor config.] <i>S , F 1</i> - Menu	329
[AI2 Sensor config.] <i>S , F 2</i> - Menu	331
[AI3 Sensor config.] <i>S , F 3</i> - Menu	333
[AI4 Sensor config.] <i>S , F 4</i> - Menu	334
[AI5 Sensor config.] <i>S , F 5</i> - Menu	336
[DI5 Sensor Configuration] <i>S , F B</i> - Menu	337
[DI6 Sensor Configuration] <i>S , F 9</i> - Menu	338
[AIV1 Sensor config.] <i>S , V 1</i> - Menu	339
[Sleep menu] <i>S L P</i> - Menu	340
[AI1 Sensor config.] <i>S a R 1</i> - Menu	341
[AI2 Sensor config.] <i>S a R 2</i> - Menu	343
[AI3 Sensor config.] <i>S a R 3</i> - Menu	345
[AI4 Sensor config.] <i>S a R 4</i> - Menu	346
[AI5 Sensor config.] <i>S a R 5</i> - Menu	348
[AIV1 Sensor config.] <i>S a V 1</i> - Menu	349
[Sleep menu] <i>S L P</i> - Menu	350
[Boost] <i>S b t</i> - Menu	351
[Advanced sleep check] <i>R d 5</i> - Menu	352
[Wake up menu] <i>W K P</i> - Menu	354
[AI1 Sensor config.] <i>W a R 1</i> - Menu	355
[AI2 Sensor config.] <i>W a R 2</i> - Menu	357
[AI3 Sensor config.] <i>W a R 3</i> - Menu	359
[AI4 Sensor config.] <i>W a R 4</i> - Menu	360
[AI5 Sensor config.] <i>W a R 5</i> - Menu	362
[AIV1 Sensor config.] <i>W a V 1</i> - Menu	363
[Wake up menu] <i>W K P</i> - Menu	364

## [Sleep/Wakeup] 5 P W - Overview

### About This Menu

Following parameters can be accessed if [PID feedback ass.] P , F is not set to [Not Configured] n o .

### WARNING

#### UNANTICIPATED EQUIPMENT OPERATION

Verify that activating this function does not result in unsafe conditions.

**Failure to follow these instructions can result in death, serious injury, or equipment damage.**

The purpose of the "Sleep / Wake-Up" function is to stop the motor in process standstill situations.

It allows you to save energy and helps to prevent premature aging of some equipment that cannot run for a long time at low speed because the greasing or cooling depends on the machine speed.

In a pressure-controlled pumping application:

- The purpose of the Sleep / Wake-Up function is to manage periods of the application where the water demand is low and where it is not needed to keep the main pumps running.
- It allows you to save energy in low demand periods. Then, when the demand is increasing, the application needs to wake up in order to meet the demand.
- Optionally, during a sleep period, a Jockey pump can be started to maintain an emergency service pressure or meet a low water demand.

Depending on user-defined wakeup conditions, the motor is restarted automatically.

### Sleep/Wake-Up in PID Control Mode

When the drive is used in PID control, one of the following conditions is used to switch the application to the sleep state:

- Sleep on low speed (when all fixed pumps are Off in case of a multi-pump application).
- Sleep on low sleep sensor value (using flow sensor for monitoring).
- Sleep on low motor power (when all fixed pumps are Off in case of a multi-pump application).
- Sleep on external condition (using drive input).

The drive is in "PID control mode" when PID is active. Typically when:

- PID is configured, and
- Channel 1 is selected, and
- PID is in automatic mode.

When the drive is in a sleep state, a wake-up condition is used to restart the application:

- Wake-up on PID Feedback level
- Wake-up on PID Error level
- Wake-up on low-pressure condition

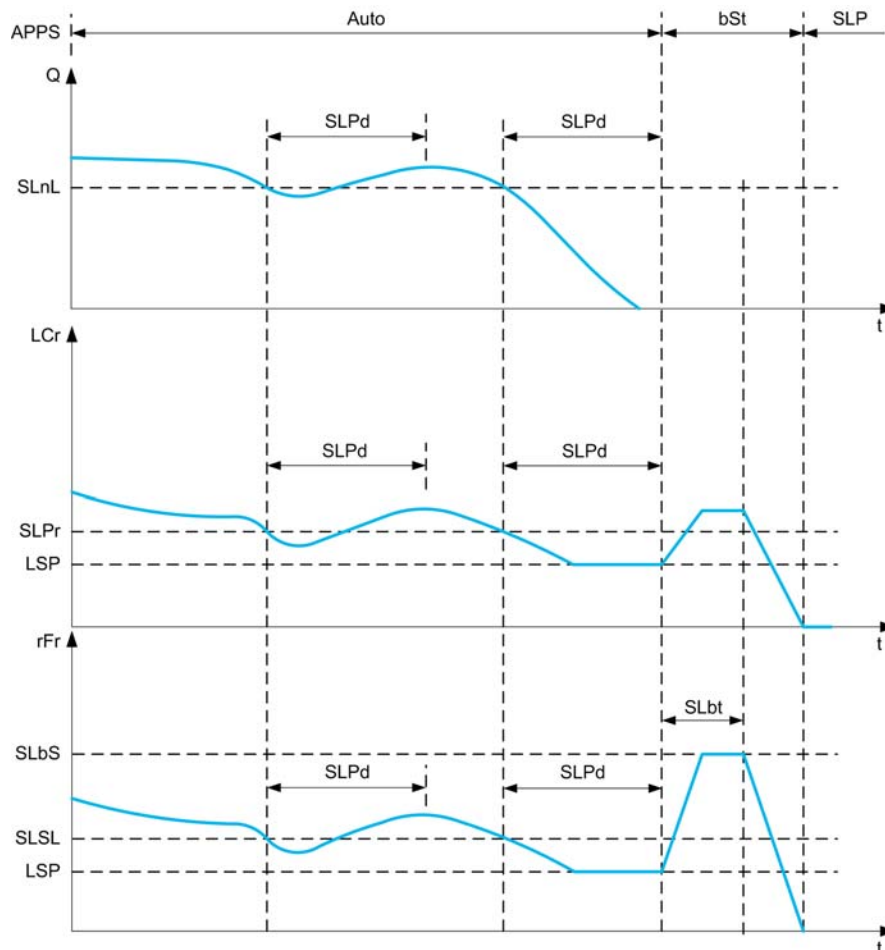

### Sleep Conditions in PID Control Mode

If there is no valid wake-up condition, then the system switches to the sleep mode after one of the configured sleep conditions remains longer than **[Sleep Delay] SLPd**.

The sleep detection mode is selected by configuring **[Sleep Detect Mode] SLPn**. Then the system switches to sleep mode if the selected condition is met:

Configuration	Condition
<b>LF</b> sleep on flow sensor value	Sensor value is below the sleep level
<b>SW</b> sleep on switch or external condition	The switch input becomes active
<b>SPd</b> sleep on speed	The output frequency is below the sleep speed and all auxiliary
<b>PWr</b> sleep on power level	The output power is below the sleep power
<b>HP</b> sleep on pressure sensor value	Sensor value is higher than the sleep level
<b>or</b> multiple conditions	At least 1 of the configured condition to enter in sleep mode is met

### Wake-Up Conditions in PID Control Mode

The system wakes up according to **[Wake Up Mode] WUPn** configuration:

- On PID Feedback level
- On PID Error level.
- On low-pressure condition.

If **[Feedback] FBK** is selected, then the system wakes up and goes back in PID control mode:

- When PID feedback drops below configured **[Wake Up Process Level] WUPF** if PID is configured in Direct mode, (**[PID Inversion] PIC** is set to **no**).
- When PID feedback raises above configured **[Wake Up Process Level] WUPF**, if PID is configured in Reverse mode (**[PID Inversion] PIC** is set to **YES**).

If **[Error] E r r** is selected, then the system wakes up and goes back in PID control mode:

- When PID feedback drops below (**[PID reference] r P C** - **[Wake Up Process Error] W u P E**), if PID is configured in Direct mode (**[PID Inversion] P , C** is set to **n o**).
- When PID feedback raises above (**[PID reference] r P C** + **[Wake Up Process Error] W u P E**), if PID is configured in Reverse mode (**[PID Inversion] P , C** is set to **y e s**).

If **[Pressure] L P** is selected, then the system wakes up and goes back in PID control mode when the pressure feedback drops below **[Wake Up Process Level] W u P F**.

### Boosting Phase in PID Control Mode

When entering the sleep mode, the motor accelerates to **[Sleep Boost Speed] S L b S** during **[Sleep Boost Time] S L b t** and then stops.

If **[Sleep Boost Time] S L b t** is set to 0, then the boost phase is ignored.

### Initial State in PID Control Mode

Just after the system starts in automatic mode (a run order appears while in automatic mode - channel 1 already selected and PID auto):

- If a wake-up condition is met, the drive goes in PID control mode (PID started).
- If a wake-up condition is not met, the drive goes in sleep mode (PID stays stopped and motor is kept halted), and Boosting phase is ignored.

When the control is switched to automatic mode while the motor is running (switch to channel 1 or switch to PID auto mode for example), the drive stays in running state and switches to PID automatic mode.

### Configuration of Sleep External Condition (Usage of a No Flow Switch for Example)

Sleep switch allows you to select the source of sleep external condition:

- **n o**: no input selected for the sleep external condition.
- **d i X**: the sleep external condition (switch for example) is connected to DIx (the assignment is also possible on a control bit in I/O profile).

### Configuration of Sleep Sensor (Flow or Pressure Sensor)

The assignment of a sleep sensor, the configuration of the selected physical input and the configuration of scaling to process value are performed.

A sleep sensor source is selected by **[Inst. Flow Assign.] F S I R** and **[OutletPres Assign] P S Z R** which allows to select the analog or pulse input on which the sensor is connected:

- **n o**: no input selected for sleep sensor value.
- **R , X**: sleep sensor is connected to AIx.
- **R , u X**: sleep sensor is connected to virtual AIUx.
- **P , X**: sleep sensor is connected to pulse input PIx.

The configuration of an analog input is performed.

The configuration of a pulse input is performed.

Depending on the selected source, the process range of the sensor is configured by:

- **[AIx Lowest Process] R , X J**, **[AIx Highest Process] R , X K** (without unit), when connected on an analog input.
- **[Alv1 Lowest Process] R V , J**, **[Alv1 Highest Process] R V , K** (without unit), when using the virtual analog input.
- **[DIx PulseInput Low Freq] P , L X**, **[DIx PulseInput High Freq] P , H X** (without unit), when connected on a pulse input configured in frequency.

**[Sleep menu] 5 L P - Menu****Access**

[Complete settings] → [Pump functions] → [Sleep/Wakeup] → [Sleep menu]

**About This Menu****[Sleep Detect Mode] 5 L P Π**

Sleep detection mode.

Setting	Code / Value	Description
[No]	<i>n o</i>	Not configured <b>Factory setting</b>
[Switch]	<i>5 w</i>	System enters in sleep mode on switch condition
[Flow]	<i>L f</i>	System enters in sleep mode on low flow condition
[Speed]	<i>5 P d</i>	System enters in sleep mode on speed condition
[Power]	<i>P w r</i>	System enters in sleep mode on power condition
[Pressure]	<i>H P</i>	System enters in sleep mode on high-pressure condition
[Multiple]	<i>o r</i>	System enters in sleep mode on multiple-OR condition

**[Sleep Switch Assign] 5 L P W**

Sleep switch assignment.

This parameter can be accessed if [Sleep Detect Mode] 5 L P Π is set to [Switch] 5 w.

Select an external condition to enter in sleep mode (for example, flow switch).

Setting	Code / Value	Description
[Not Assigned]	<i>n o</i>	Not assigned <b>Factory setting</b>
[DI1]...[DI6]	<i>L , I ... L , I 6</i>	Digital input DI1...DI6
[DI11]...[DI16]	<i>L , I I ... L , I 16</i>	Digital input DI11...DI16 if VW3A3203 I/O extension module has been inserted
[CD00]...[CD10]	<i>C d 0 0 ... C d 1 0</i>	Virtual digital input CMD.0...CMD.10 in [I/O profile] , o configuration
[CD11]...[CD15]	<i>C d 1 1 ... C d 1 5</i>	Virtual digital input CMD.11...CMD.15 regardless of configuration
[C100]...[C110]	<i>C 1 0 0 ... C 1 1 0</i>	Virtual digital input CMD1.0...CMD1.10 with integrated Modbus Serial in [I/O profile] , o configuration
[C111]...[C115]	<i>C 1 1 1 ... C 1 1 5</i>	Virtual digital input CMD1.11...CMD1.15 with integrated Modbus Serial regardless of configuration
[C200]...[C210]	<i>C 2 0 0 ... C 2 1 0</i>	Virtual digital input CMD2.0...CMD2.10 with CANopen® fieldbus module in [I/O profile] , o configuration
[C211]...[C215]	<i>C 2 1 1 ... C 2 1 5</i>	Virtual digital input CMD2.11...CMD2.15 with CANopen® fieldbus module regardless of configuration
[C300]...[C310]	<i>C 3 0 0 ... C 3 1 0</i>	Virtual digital input CMD3.0...CMD3.10 with a fieldbus module in [I/O profile] , o configuration
[C311]...[C315]	<i>C 3 1 1 ... C 3 1 5</i>	Virtual digital input CMD3.11...CMD3.15 with a fieldbus module regardless of configuration
[C500]...[C510]	<i>C 5 0 0 ... C 5 1 0</i>	Virtual digital input CMD5.0...CMD5.10 with integrated Ethernet Modbus TCP in [I/O profile] , o configuration
[C511]...[C515]	<i>C 5 1 1 ... C 5 1 5</i>	Virtual digital input CMD5.11...CMD5.15 with integrated Ethernet Modbus TCP regardless of configuration
[DI1 (Low level)]...[DI6 (Low level)]	<i>L I L ... L I 6 L</i>	Digital input DI1...DI6 used at low level
[DI11 (Low level)]...[DI16 (Low level)]	<i>L I I L ... L I 16 L</i>	Digital input DI11...DI16 used at low level if VW3A3203 I/O extension module has been inserted

**[Inst. Flow Assign.] F 5 I R** ★

Installation flow sensor assignment.

This parameter can be accessed if **[Sleep Detect Mode] 5 L P 11** is set to **[Sensor] 5 n 5 r**.

Setting	Code / Value	Description
<b>[Not Configured]</b>	<i>n a</i>	Not assigned <b>Factory setting</b>
<b>[AI1]...[AI3]</b>	<i>R , 1...R , 3</i>	Analog input AI1...AI3
<b>[AI4]...[AI5]</b>	<i>R , 4...R , 5</i>	Analog input AI4...AI5 if VW3A3203 I/O extension module has been inserted
<b>[AI Virtual 1]</b>	<i>R , V 1</i>	Virtual analogic input 1
<b>[PulseInput Assignment On DI5]...[PulseInput Assignment On DI6]</b>	<i>P , 5...P , 6</i>	Digital input DI5...DI6 used as pulse input
<b>[Flow Estimation]</b>	<i>5 L P F</i>	Sensor less estimated flow



## [AI1 Sensor config.] 5 , F I - Menu

### Access

[Complete settings] → [Pump functions] → [Sleep/wakeup] → [Sleep menu] → [AI1 Sensor config.]

### About This Menu

This menu can be accessed if:

- [Inst. Flow Assign.] F 5 I R is set to [AI1] R , I, and
- [Sleep Detect Mode] 5 L P N is set to
  - [Flow] L F, or
  - [Multiple] a r .

### [AI1 Type] R , I E

Configuration of analog input AI1.

Setting	Code / Value	Description
[Voltage]	I 0 u	0-10 Vdc <b>Factory setting</b>
[Current]	0 R	0-20 mA

### [AI1 min value] u , L I ★

AI1 voltage scaling parameter of 0%.

This parameter can be accessed if [AI1 Type] R , I E is set to [Voltage] I 0 u.

Setting	Description
0.0...10.0 Vdc	Setting range <b>Factory setting:</b> 0.0 Vdc

### [AI1 max value] u , H I ★

AI1 voltage scaling parameter of 100%.

This parameter can be accessed if [AI1 Type] R , I E is set to [Voltage] I 0 u.

Setting	Description
0.0...10.0 Vdc	Setting range <b>Factory setting:</b> 10.0 Vdc

### [AI1 min. value] C r L I ★

AI1 current scaling parameter of 0%.

This parameter can be accessed if [AI1 Type] R , I E is set to [Current] a R.

Setting	Description
0.0...20.0 mA	Setting range <b>Factory setting:</b> 0.0 mA

### [AI1 max. value] C r H I ★

AI1 current scaling parameter of 100%.

This parameter can be accessed if [AI1 Type] R , I E is set to [Current] a R.

Setting	Description
0.0...20.0 mA	Setting range <b>Factory setting:</b> 20.0 mA

**[A11 Lowest Process] R , I J**

A11 lowest process.

Setting	Description
-32,768...32,767	Setting range. Value in application customer unit. <b>Factory setting:</b> 0

**[A11 Highest Process] R , I K**

A11 highest process.

Setting	Description
-32,768...32,767	Setting range. Value in application customer unit. <b>Factory setting:</b> 0

## [AI2 Sensor config.] 5 , F 2 - Menu

### Access

[Complete settings] → [Pump functions] → [Sleep/wakeup] → [Sleep menu] → [AI2 Sensor config.]

### About This Menu

This menu can be accessed if:

- [Inst. Flow Assign.] F 5 I A is set to [AI2] A , 2 , and
- [Sleep Detect Mode] 5 L P A is set to
  - [Flow] L F , or
  - [Multiple] a r .

### [AI2 Type] A , 2 E

Configuration of analog input AI2.

Setting	Code / Value	Description
[Voltage]	1 0 u	0-10 Vdc <b>Factory setting</b>
[Current]	a A	0-20 mA
[PTC Management]	P E C	1 to 6 PTC (in serial)
[KTY]	K E Y	1 KTY84
[PT1000]	1 P E 3	1 PT1000 connected with 2 wires
[PT100]	1 P E 2	1 PT100 connected with 2 wires
[Water Prob]	L E u E L	Water level
[3PT1000]	3 P E 3	3 PT1000 connected with 2 wires
[3PT100]	3 P E 2	3 PT100 connected with 2 wires

### [AI2 min value] u , L 2 ★

AI2 voltage scaling parameter of 0%.

This parameter can be accessed if [AI2 Type] A , 2 E is set to [Voltage] 1 0 u.

Identical to [AI1 min value] u , L 1 (see page 329).

### [AI2 max value] u , H 2 ★

AI2 voltage scaling parameter of 100%.

This parameter can be accessed if [AI2 Type] A , 2 E is set to [Voltage] 1 0 u.

Identical to [AI1 max value] u , H 1 (see page 329).

### [AI2 min. value] C r L 2 ★

AI2 current scaling parameter of 0%.

This parameter can be accessed if [AI2 Type] A , 2 E is set to [Current] a A.

Identical to [AI1 min. value] C r L 1 (see page 329).

### [AI2 max. value] C r H 2 ★

AI2 current scaling parameter of 100%.

This parameter can be accessed if [AI2 Type] A , 2 E is set to [Current] a A.

Identical to [AI1 max. value] C r H 1 (see page 329).

**[AI2 Lowest Process] R , 2 J**

AI2 lowest process.

Identical to **[AI1 Lowest Process] R , 1 J** (*see page 330*).

**[AI2 Highest Process] R , 2 K**

AI2 highest process.

Identical to **[AI1 Highest Process] R , 1 K** (*see page 330*).

## [AI3 Sensor config.] 5 , F 3 - Menu

### Access

[Complete settings] → [Pump functions] → [Sleep/wakeup] → [Sleep menu] → [AI3 Sensor config.]

### About this menu

This menu can be accessed if:

- [Inst. Flow Assign.] F 5 I A is set to [AI3] A , 3 , and
- [Sleep Detect Mode] 5 L P N is set to
  - [Flow] L F , or
  - [Multiple] 0 r .

### [AI3 Type] A , 3 E

Configuration of analog input AI3.

Identical to [AI2 Type] A , 2 E (see page 331) with factory setting: [Current] 0 A .

### [AI3 min value] 0 , L 3 ★

AI3 voltage scaling parameter of 0%.

This parameter can be accessed if A , 3 E is set to [Voltage] 1 0 0 .

Identical to [AI1 min value] 0 , L 1 (see page 329).

### [AI3 max value] 0 , H 3 ★

AI3 voltage scaling parameter of 100%.

This parameter can be accessed if A , 3 E is set to [Voltage] 1 0 0 .

Identical to [AI1 max value] 0 , H 1 (see page 329).

### [AI3 min. value] C r L 3 ★

AI3 current scaling parameter of 0%.

This parameter can be accessed if A , 3 E is set to [Current] 0 A .

Identical to [AI1 min. value] C r L 1 (see page 329).

### [AI3 max. value] C r H 3 ★

AI3 current scaling parameter of 100%.

This parameter can be accessed if A , 3 E is set to [Current] 0 A .

Identical to [AI1 max. value] C r H 1 (see page 329).

### [AI3 Lowest Process] A , 3 J

AI3 lowest process.

Identical to [AI1 Lowest Process] A , 1 J (see page 330).

### [AI3 Highest Process] A , 3 K

AI3 highest process.

Identical to [AI1 Highest Process] A , 1 K (see page 330).

## [AI4 Sensor config.] 5 , F 4 - Menu

### Access

[Complete settings] → [Pump functions] → [Sleep/wakeup] → [Sleep menu] → [AI4 Sensor config.]

### About This Menu

This menu can be accessed if:

- [Inst. Flow Assign.] F 5 I A is set to [AI4] A , 4 , and
- [Sleep Detect Mode] 5 L P N is set to
  - [Flow] L F , or
  - [Multiple] a r .

### [AI4 Type] A , 4 E ★

Configuration of analog input AI4.

This parameter can be accessed if VW3A3203 I/O extension module has been inserted.

Setting	Code / Value	Description
[Voltage]	1 0 u	0-10 Vdc
[Current]	0 A	0-20 mA
[Voltage +/-]	n 1 0 u	-10/+10 Vdc <b>Factory setting</b>
[PTC Management]	P E C	1 to 6 PTC (in serial)
[KTY]	K E Y	1 KTY84
[PT1000]	1 P E 3	1 PT1000 connected with 2 wires
[PT100]	1 P E 2	1 PT100 connected with 2 wires
[3 PT1000]	3 P E 3	3 PT1000 connected with 2 wires
[3 PT100]	3 P E 2	3 PT100 connected with 2 wires
[PT1000 in 3 wires]	1 P E 3 3	1 PT1000 connected with 3 wires (AI4 & AI5 only)
[PT100 in 3 wires]	1 P E 2 3	1 PT100 connected with 3 wires (AI4 & AI5 only)
[3 PT1000 in 3 wires]	3 P E 3 3	3 PT1000 connected with 3 wires (AI4 & AI5 only)
[3 PT100 in 3 wires]	3 P E 2 3	3 PT100 connected with 3 wires (AI4 & AI5 only)

### [AI4 min value] u , L 4 ★

AI4 voltage scaling parameter of 0%.

Identical to [AI1 min value] u , L 1 (see page 329).

### [AI4 max value] u , H 4 ★

AI4 voltage scaling parameter of 100%.

Identical to [AI1 max value] u , H 1 (see page 329).

### [AI4 min. value] C r L 4 ★

AI4 current scaling parameter of 0%.

Identical to [AI1 min. value] C r L 1 (see page 329).

### [AI4 max. value] C r H 4 ★

AI4 current scaling parameter of 100%.

Identical to [AI1 max. value] C r H 1 (see page 329).

**[AI4 Lowest Process] R , 4 J**

AI4 lowest process.

Identical to **[AI1 Lowest Process] R , 1 J** (*see page 330*).

**[AI4 Highest Process] R , 4 K**

AI4 highest process.

Identical to **[AI1 Highest Process] R , 1 K** (*see page 330*).

## [AI5 Sensor config.] 5 , F 5 - Menu

### Access

[Complete settings] → [Pump functions] → [Sleep/wakeup] → [Sleep menu] → [AI5 Sensor config.]

### About This Menu

This menu can be accessed if:

- [Inst. Flow Assign.] F 5 I A is set to [AI5] A , 5 , and
- [Sleep Detect Mode] 5 L P N is set to
  - [Flow] L F , or
  - [Multiple] a r .

### [AI5 Type] A , 5 E ★

Configuration of analog input AI5.

This parameter can be accessed if VW3A3203 relay output option module has been inserted.

Identical to [AI4 Type] A , 4 E (see page 334).

### [AI5 min value] u , L 5 ★

AI5 voltage scaling parameter of 0%.

Identical to [AI1 min value] u , L 1 (see page 329).

### [AI5 max value] u , H 5 ★

AI5 voltage scaling parameter of 100%.

Identical to [AI1 max value] u , H 1 (see page 329).

### [AI5 min. value] C r L 5 ★

AI5 current scaling parameter of 0%.

Identical to [AI1 min. value] C r L 1 (see page 329).

### [AI5 max. value] C r H 5 ★

AI5 current scaling parameter of 100%.

Identical to [AI1 max. value] C r H 1 (see page 329).

### [AI5 Lowest Process] A , 5 J

AI5 lowest process.

Identical to [AI1 Lowest Process] A , 1 J (see page 330).

### [AI5 Highest Process] A , 5 K

AI5 highest process.

Identical to [AI1 Highest Process] A , 1 K (see page 330).



## [DI5 Sensor Configuration] 5 , F B - Menu

### Access

[Complete settings] → [Pump functions] → [Sleep/wakeup] → [Sleep menu] → [DI5 Sensor Configuration]

### About This Menu

This menu can be accessed if:

- [Inst. Flow Assign.] F 5 I A is set to [DI5 PulseInput Assignment] P , 5 , and
- [Sleep Detect Mode] 5 L P Π is set to
  - [Flow] L F , or
  - [Multiple] α r .

### [DI5 PulseInput Low Freq] P , L 5

DI5 pulse input low frequency.

Setting	Description
0.00...30,000.00 Hz	Setting range Factory setting: 0.00 Hz

### [DI5 PulseInput High Freq] P , H 5

DI5 pulse input high frequency.

Setting	Description
0.00...30.00 kHz	Setting range Factory setting: 30.00 kHz

### [DI5 Min Process] P , 5 J

Minimum process value for selected input.

Setting	Description
-32,767...32,767	Setting range Factory setting: 0

### [DI5 Max Process] P , 5 K

Maximum process value for selected input.

Setting	Description
-32,767...32,767	Setting range Factory setting: 0

## [DI6 Sensor Configuration] 5 , F 9 - Menu

### Access

[Complete settings] → [Pump functions] → [Sleep/wakeup] → [Sleep menu] → [DI6 Sensor Configuration]

### About This Menu

Identical to [DI5 Sensor Configuration] 5 , F 8 - Menu (*see page 337*).

This menu can be accessed if:

- [Inst. Flow Assign.] F 5 I A is set to [DI6 PulseInput Assignment] P , E, and
- [Sleep Detect Mode] 5 L P Π is set to
  - [Flow] L F, or
  - [Multiple] 0 r.

### [DI6 PulseInput Low Freq] P , L E

DI6 pulse input low frequency.

### [DI6 PulseInput High Freq] P , H E

DI6 pulse input high frequency.

### [DI6 Min Process] P , E J

Minimum process value for selected input.

### [DI6 Max Process] P , E K

Maximum process value for selected input.

## [AIV1 Sensor config.] 5 , V / - Menu

### Access

[Complete settings] → [Pump functions] → [Sleep/wakeup] → [Sleep menu] → [AIV1 Sensor config.]

### About This Menu

This menu can be accessed if:

- [Inst. Flow Assign.] *F 5 I A* is set to [AI Virtual 1] *A 1 U I*, and
- [Sleep Detect Mode] *5 L P N* is set to
  - [Flow] *L F*, or
  - [Multiple] *a r*.

### [AIV1 Channel Assignment] *A 1 C I*

Channel assignment for virtual analog input AIV1.

Setting	Code / Value	Description
[Not Configured]	<i>n o</i>	Not assigned <b>Factory setting</b>
[Ref. Freq-Modbus]	<i>n d b</i>	Reference frequency via Modbus
[Ref. Freq-CANopen]	<i>C A n</i>	Reference frequency via CANopen if a CANopen module has been inserted
[Ref. Freq-Com. Module]	<i>n E t</i>	Reference frequency via fieldbus module if a fieldbus module has been inserted
[Embedded Ethernet]	<i>E t H</i>	Embedded Ethernet

### [AIV1 Lowest Process] *A 1 I J*

AI virtual x: minimum process value.

Setting	Description
-32,767...32,767	Setting range <b>Factory setting: 0</b>

### [AIV1 Highest Process] *A 1 I K*

AI virtual x: maximum process value.

Setting	Description
-32,767...32,767	Setting range <b>Factory setting: 0</b>

**[Sleep menu] 5 L P - Menu**

**Access**

[Complete settings] → [Pump functions] → [Sleep/wakeup] → [Sleep menu]

**[Sleep Flow Level] 5 L n L ★**

Sleep flow level.

Sensor level under which the system should enter the sleep mode (Zero value to deactivate).

This parameter can be accessed if:

- [Inst. Flow Assign.] F 5 I R is not set to [Not Configured] n o, and
- [Sleep Detect Mode] 5 L P Π is set to
  - [Flow] L F, or
  - [Multiple] o r.

Setting ( )	Description
[No] n o to 32,767	Setting range Unit: [Flow rate unit] 5 u F r (for example, %, l/s; m3/h) Factory setting: [No] n o

**[OutletPres Assign] P 5 2 R ★**

Outlet pressure sensor assignment.

This parameter can be accessed if:

- [Sleep Detect Mode] 5 L P Π is set to [Pressure] H P, or
- [Sleep Detect Mode] 5 L P Π is set to [Multiple] o r.

Setting	Code / Value	Description
[Not Configured]	n o	Not assigned Factory setting
[AI1]...[AI3]	R , 1...R , 3	Analog input AI1...AI3
[AI4]...[AI5]	R , 4...R , 5	Analog input AI4...AI5 if VW3A3203 I/O extension module has been inserted
[AI Virtual 1]	R , V 1	Virtual analogic input 1

## [AI1 Sensor config.] 5 0 R I - Menu

### Access

[Complete settings] → [Pump functions] → [Sleep/wakeup] → [Sleep menu] → [AI1 Sensor config.]

### About This Menu

This menu can be accessed if:

- [OutletPres Assign] P 5 2 R is set to [AI1] R , I, and
- [Sleep Detect Mode] 5 L P Π is set to
  - [Pressure] H P, or
  - [Multiple] 0 r .

### [AI1 Type] R , I E

Configuration of analog input AI1.

Setting	Code / Value	Description
[Voltage]	I 0 u	0-10 Vdc <b>Factory setting</b>
[Current]	0 R	0-20 mA

### [AI1 min value] u , L I ★

AI1 voltage scaling parameter of 0%.

This parameter can be accessed if [AI1 Type] R , I E is set to [Voltage] I 0 u.

Setting	Description
0.0...10.0 Vdc	Setting range <b>Factory setting:</b> 0.0 Vdc

### [AI1 max value] u , H I ★

AI1 voltage scaling parameter of 100%.

This parameter can be accessed if [AI1 Type] R , I E is set to [Voltage] I 0 u.

Setting	Description
0.0...10.0 Vdc	Setting range <b>Factory setting:</b> 10.0 Vdc

### [AI1 min. value] C r L I ★

AI1 current scaling parameter of 0%.

This parameter can be accessed if [AI1 Type] R , I E is set to [Current] 0 R.

Setting	Description
0.0...20.0 mA	Setting range <b>Factory setting:</b> 0.0 mA

### [AI1 max. value] C r H I ★

AI1 current scaling parameter of 100%.

This parameter can be accessed if [AI1 Type] R , I E is set to [Current] 0 R.

Setting	Description
0.0...20.0 mA	Setting range <b>Factory setting:</b> 20.0 mA

**[A11 Lowest Process] R , I J**

A11 lowest process.

Setting	Description
-32,768...32,767	Setting range. Value in application customer unit. <b>Factory setting:</b> 0

**[A11 Highest Process] R , I K**

A11 highest process.

Setting	Description
-32,768...32,767	Setting range. Value in application customer unit. <b>Factory setting:</b> 0

## [AI2 Sensor config.] 5 0 A 2 - Menu

### Access

[Complete settings] → [Pump functions] → [Sleep/wakeup] → [Sleep menu] → [AI2 Sensor config.]

### About This Menu

This menu can be accessed if:

- [OutletPres Assign] P 5 2 A is set to [AI2] A , 2 , and
- [Sleep Detect Mode] 5 L P Π is set to
  - [Pressure] H P , or
  - [Multiple] 0 r .

### [AI2 Type] A , 2 Ɛ

Configuration of analog input AI2.

Setting	Code / Value	Description
[Voltage]	1 0 Ʃ	0-10 Vdc <b>Factory setting</b>
[Current]	0 A	0-20 mA
[PTC Management]	P Ɛ C	1 to 6 PTC (in serial)
[KTY]	K Ɛ Y	1 KTY84
[PT1000]	1 P Ɛ 3	1 PT1000 connected with 2 wires
[PT100]	1 P Ɛ 2	1 PT100 connected with 2 wires
[Water Prob]	L E Ʃ E L	Water level
[3PT1000]	3 P Ɛ 3	3 PT1000 connected with 2 wires
[3PT100]	3 P Ɛ 2	3 PT100 connected with 2 wires

### [AI2 min value] Ʃ , L 2 ★

AI2 voltage scaling parameter of 0%.

This parameter can be accessed if [AI2 Type] A , 2 Ɛ is set to [Voltage] 1 0 Ʃ.

Identical to [AI1 min value] Ʃ , L 1 (see page 341).

### [AI2 max value] Ʃ , H 2 ★

AI2 voltage scaling parameter of 100%.

This parameter can be accessed if [AI2 Type] A , 2 Ɛ is set to [Voltage] 1 0 Ʃ.

Identical to [AI1 max value] Ʃ , H 1 (see page 341).

### [AI2 min. value] C r L 2 ★

AI2 current scaling parameter of 0%.

This parameter can be accessed if [AI2 Type] A , 2 Ɛ is set to [Current] 0 A.

Identical to [AI1 min. value] C r L 1 (see page 341).

### [AI2 max. value] C r H 2 ★

AI2 current scaling parameter of 100%.

This parameter can be accessed if [AI2 Type] A , 2 Ɛ is set to [Current] 0 A.

Identical to [AI1 max. value] C r H 1 (see page 341).

**[AI2 Lowest Process] R , 2 J**

AI2 lowest process.

Identical to **[AI1 Lowest Process] R , 1 J** (*see page 342*).

**[AI2 Highest Process] R , 2 K**

AI2 highest process.

Identical to **[AI1 Highest Process] R , 1 K** (*see page 342*).



## [AI3 Sensor config.] 5 0 A 3 - Menu

### Access

[Complete settings] → [Pump functions] → [Sleep/wakeup] → [Sleep menu] → [AI3 Sensor config.]

### About this menu

This menu can be accessed if:

- [OutletPres Assign] P 5 2 A is set to [AI3] A , 3 , and
- [Sleep Detect Mode] 5 L P 11 is set to
  - [Pressure] H P , or
  - [Multiple] 0 r .

### [AI3 Type] A , 3 E

Configuration of analog input AI3.

Identical to [AI2 Type] A , 2 E (see page 343) with factory setting: [Current] 0 A .

### [AI3 min value] 0 , L 3 ★

AI3 voltage scaling parameter of 0%.

This parameter can be accessed if A , 3 E is set to [Voltage] 1 0 0 .

Identical to [AI1 min value] 0 , L 1 (see page 341).

### [AI3 max value] 0 , H 3 ★

AI3 voltage scaling parameter of 100%.

This parameter can be accessed if A , 3 E is set to [Voltage] 1 0 0 .

Identical to [AI1 max value] 0 , H 1 (see page 341).

### [AI3 min. value] C r L 3 ★

AI3 current scaling parameter of 0%.

This parameter can be accessed if A , 3 E is set to [Current] 0 A .

Identical to [AI1 min. value] C r L 1 (see page 341).

### [AI3 max. value] C r H 3 ★

AI3 current scaling parameter of 100%.

This parameter can be accessed if A , 3 E is set to [Current] 0 A .

Identical to [AI1 max. value] C r H 1 (see page 341).

### [AI3 Lowest Process] A , 3 J

AI3 lowest process.

Identical to [AI1 Lowest Process] A , 1 J (see page 342).

### [AI3 Highest Process] A , 3 K

AI3 highest process.

Identical to [AI1 Highest Process] A , 1 K (see page 342).

## [AI4 Sensor config.] 5 0 R 4 - Menu

### Access

[Complete settings] → [Pump functions] → [Sleep/wakeup] → [Sleep menu] → [AI4 Sensor config.]

### About This Menu

This menu can be accessed if:

- [OutletPres Assign] P 5 2 R is set to [AI4] R , 4, and
- [Sleep Detect Mode] 5 L P Π is set to
  - [Pressure] H P, or
  - [Multiple] 0 r .

### [AI4 Type] R , 4 L ★

Configuration of analog input AI4.

This parameter can be accessed if VW3A3203 I/O extension module has been inserted.

Setting	Code / Value	Description
[Voltage]	1 0 u	0-10 Vdc
[Current]	0 R	0-20 mA
[Voltage +/-]	n 1 0 u	-10/+10 Vdc <b>Factory setting</b>
[PTC Management]	P E C	1 to 6 PTC (in serial)
[KTY]	K E Y	1 KTY84
[PT1000]	1 P E 3	1 PT1000 connected with 2 wires
[PT100]	1 P E 2	1 PT100 connected with 2 wires
[3 PT1000]	3 P E 3	3 PT1000 connected with 2 wires
[3 PT100]	3 P E 2	3 PT100 connected with 2 wires
[PT1000 in 3 wires]	1 P E 3 3	1 PT1000 connected with 3 wires (AI4 & AI5 only)
[PT100 in 3 wires]	1 P E 2 3	1 PT100 connected with 3 wires (AI4 & AI5 only)
[3 PT1000 in 3 wires]	3 P E 3 3	3 PT1000 connected with 3 wires (AI4 & AI5 only)
[3 PT100 in 3 wires]	3 P E 2 3	3 PT100 connected with 3 wires (AI4 & AI5 only)

### [AI4 min value] u , L 4 ★

AI4 voltage scaling parameter of 0%.

Identical to [AI1 min value] u , L 1 (see page 341).

### [AI4 max value] u , H 4 ★

AI4 voltage scaling parameter of 100%.

Identical to [AI1 max value] u , H 1 (see page 341).

### [AI4 min. value] C r L 4 ★

AI4 current scaling parameter of 0%.

Identical to [AI1 min. value] C r L 1 (see page 341).

### [AI4 max. value] C r H 4 ★

AI4 current scaling parameter of 100%.

Identical to [AI1 max. value] C r H 1 (see page 341).

**[AI4 Lowest Process] R , 4 J**

AI4 lowest process.

Identical to **[AI1 Lowest Process] R , 1 J** (*see page 342*).

**[AI4 Highest Process] R , 4 K**

AI4 highest process.

Identical to **[AI1 Highest Process] R , 1 K** (*see page 342*).

## [AI5 Sensor config.] 5 ▢ R 5 - Menu

### Access

[Complete settings] → [Pump functions] → [Sleep/wakeup] → [Sleep menu] → [AI5 Sensor config.]

### About This Menu

This menu can be accessed if:

- [OutletPres Assign] P 5 2 R is set to [AI5] R , 5, and
- [Sleep Detect Mode] 5 L P Π is set to
  - [Pressure] H P, or
  - [Multiple] ▢ r .

### [AI5 Type] R , 5 L ★

Configuration of analog input AI5.

This parameter can be accessed if VW3A3203 relay output option module has been inserted.

Identical to [AI4 Type] R , 4 L (see page 346).

### [AI5 min value] ▢ , L 5 ★

AI5 voltage scaling parameter of 0%.

Identical to [AI1 min value] ▢ , L 1 (see page 341).

### [AI5 max value] ▢ , H 5 ★

AI5 voltage scaling parameter of 100%.

Identical to [AI1 max value] ▢ , H 1 (see page 341).

### [AI5 min. value] C r L 5 ★

AI5 current scaling parameter of 0%.

Identical to [AI1 min. value] C r L 1 (see page 341).

### [AI5 max. value] C r H 5 ★

AI5 current scaling parameter of 100%.

Identical to [AI1 max. value] C r H 1 (see page 341).

### [AI5 Lowest Process] R , 5 J

AI5 lowest process.

Identical to [AI1 Lowest Process] R , 1 J (see page 342).

### [AI5 Highest Process] R , 5 K

AI5 highest process.

Identical to [AI1 Highest Process] R , 1 K (see page 342).

## [AIV1 Sensor config.] 5 0 V / - Menu

### Access

[Complete settings] → [Pump functions] → [Sleep/wakeup] → [Sleep menu] → [AIV1 Sensor config.]

### About This Menu

This menu can be accessed if:

- [OutletPres Assign] P 5 2 A is set to [AI Virtual 1] A 1 0 I, and
- [Sleep Detect Mode] 5 L P 0 is set to
  - [Pressure] H P, or
  - [Multiple] 0 r .

### [AIV1 Channel Assignment] A 1 C 1

Channel assignment for virtual analog input AIV1.

Setting	Code / Value	Description
[Not Configured]	n 0	Not assigned <b>Factory setting</b>
[Ref. Freq-Modbus]	0 d b	Reference frequency via Modbus
[Ref. Freq-CANopen]	C A n	Reference frequency via CANopen if a CANopen module has been inserted
[Ref. Freq-Com. Module]	n E t	Reference frequency via fieldbus module if a fieldbus module has been inserted
[Embedded Ethernet]	E t H	Embedded Ethernet

### [AIV1 Lowest Process] A 1 I J

AI virtual x: minimum process value.

Setting	Description
-32,767...32,767	Setting range <b>Factory setting: 0</b>

### [AIV1 Highest Process] A 1 I K

AI virtual x: maximum process value.

Setting	Description
-32,767...32,767	Setting range <b>Factory setting: 0</b>

## [Sleep menu] *SLP* - Menu

### Access

[Complete settings] → [Pump functions] → [Sleep/wakeup] → [Sleep menu]

### [Sleep Pressure Level] *SLPL*

Sleep pressure level.

This parameter can be accessed if:

- [OutletPres Assign] *PS2R* is not set to [Not Configured] *no*, and
- [Sleep Detect Mode] *SLPN* is set to
  - [Pressure] *HP*, or
  - [Multiple] *or*.

Setting ( )	Description
[No] <i>no</i> to 32,767	Setting range Unit: [Flow rate unit] <i>SUR</i> (for example, %, l/s; m3/h) Factory setting: [No] <i>no</i>

### [Sleep Min Speed] *SLSL* ★

Sleep flow level.

Speed level under which the system should enter the sleep mode.

This parameter can be accessed if:

- [Sleep Detect Mode] *SLPN* is set to [Speed] *SPd*, or
- [Sleep Detect Mode] *SLPN* is set to [Multiple] *or*.

Setting ( )	Description
0...500.0 Hz	Setting range Factory setting: [No] <i>no</i>

### [Sleep Power Level] *SLPr* ★

Sleep power level.

Power level under which the system should enter the sleep mode.

This parameter can be accessed if:

- [Sleep Detect Mode] *SLPN* is set to [Power] *Pwr*, or
- [Sleep Detect Mode] *SLPN* is set to [Multiple] *or*.

Setting ( )	Description
0...[Nominal Motor Power] <i>nPr</i>	Setting range Factory setting: [No] <i>no</i>

### [Sleep Delay] *SLPd* ★

Sleep delay.

This parameter can be accessed if [Sleep Detect Mode] *SLPN* is not set to [Not Configured] *no*.

Setting ( )	Description
0...3,600 s	Setting range Factory setting: 20 s

**[Boost] 5 b t - Menu****Access**

[Complete settings] → [Pump functions] → [Sleep/wakeup] → [Sleep menu] → [Boost]

**About This Menu**

Following parameters can be accessed if [Sleep Detect Mode] 5 L P 7 is not set to [No] n o.

**[Sleep Boost Speed] 5 L b 5 ★**

Sleep boost speed.

Setting ( )	Description
0...500.0 Hz	Setting range Factory setting: n o

**[Sleep Boost Time] 5 L b t ★**

Sleep boost time.

This parameter can be accessed if [Sleep Boost Speed] 5 L b 5 is not set to 0.

Setting ( )	Description
0...3,600 s	Setting range Factory setting: n o

## [Advanced sleep check] *AdS* - Menu

### Access

[Complete settings] → [Pump functions] → [Sleep/wakeup] → [Sleep menu] → [Advanced sleep check]

### About This Menu

This function can be activated if [Type of control] *ELC* is set to [Speed] *SPD* or [Power] *PWR*.

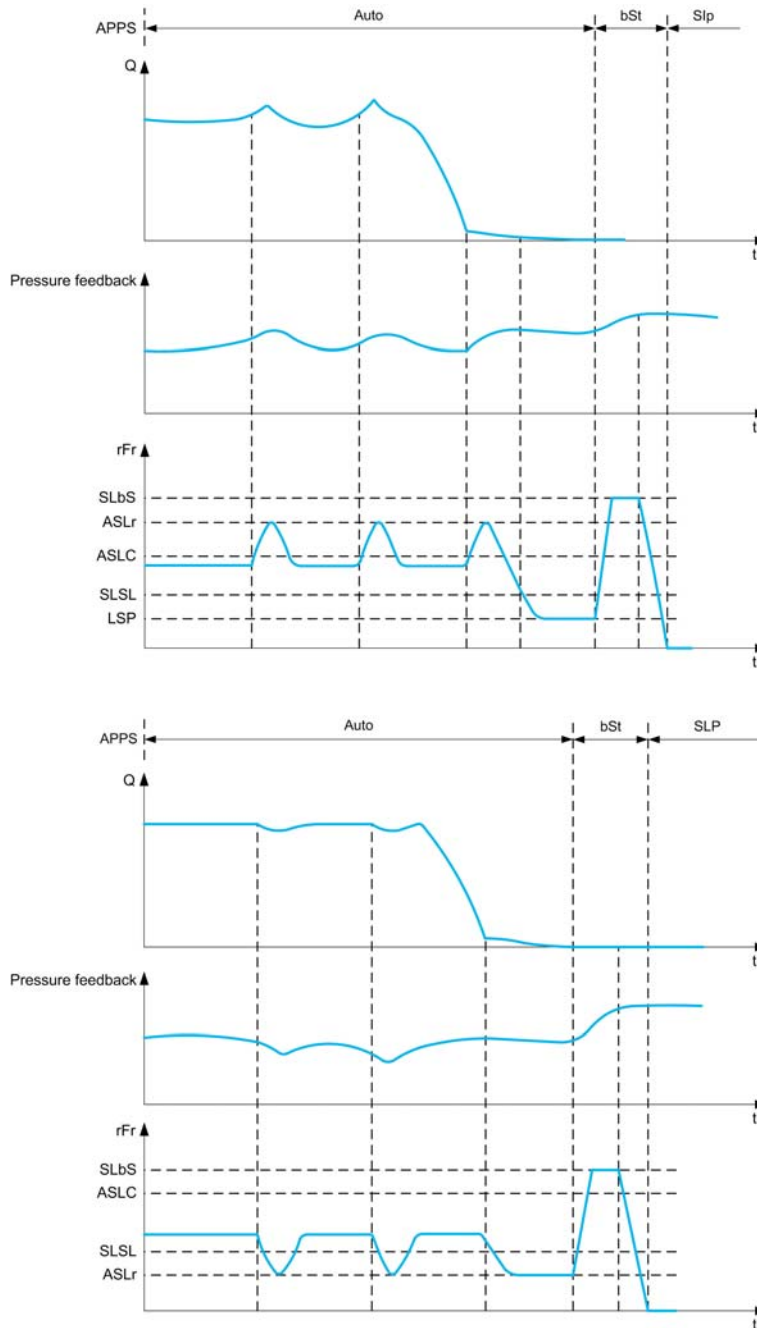



**[Sleep Mode] # 5 L 0**

Advanced sleep mode.

Setting ( )	Code / Value	Description
[No]	n o	No <b>Factory setting</b>
[YES]	y e s	Yes

**[Sleep Condition] # 5 L 1 ★**

Advanced sleep verifies speed condition.

This parameter can be accessed if **[Sleep Mode] # 5 L 0** is not set to **[No] n o**.

Setting ( )	Description
0...[High Speed] H 5 P	Setting range <b>Factory setting:</b> 0.0 Hz

**[Sleep Delay] # 5 L 2 ★**

Advanced sleep verifies delay.

This parameter can be accessed if **[Sleep Mode] # 5 L 0** is not set to **[No] n o**.

Setting ( )	Description
0...9,999 s	Setting range <b>Factory setting:</b> 20 s

**[Check Sleep Ref Spd] # 5 L 3 ★**

Advanced sleep verifies speed reference.

This parameter can be accessed if **[Sleep Mode] # 5 L 0** is not set to **[No] n o**.

Setting ( )	Description
0...[High Speed] H 5 P	Setting range <b>Factory setting:</b> 0.0 Hz

**[Wake up menu] WK P - Menu****Access**

[Complete settings] → [Pump functions] → [Sleep/wakeup] → [Wake up menu]

**About This Menu**

This menu can be accessed if [Sleep Detect Mode] *SLP* is not set to [Not Configured] *no*.

**[Wake Up Mode] WUP ★**

Wake-up mode.

Setting	Code / Value	Description
[Feedback]	<i>FBK</i>	Wake-up on PID feedback level <b>Factory setting</b>
[Error]	<i>ERR</i>	Wake-up on PID error level
[Pressure]	<i>LP</i>	Wake-up on low-pressure condition

**[Wake Up Process Level] WUPF ★**

Wake-up process value level.

This parameter can be accessed if [Wake Up Mode] *WUP* is set to [Feedback] *FBK*.

Setting ( )	Description
[Min PID feedback] <i>P1F1</i> ...[Max PID feedback] <i>P1F2</i>	Setting range <b>Factory setting: 0</b>

**[Wake Up Process Error] WUPE ★**

Wake-up process value error level.

This parameter can be accessed if [Wake Up Mode] *WUP* is set to [Error] *ERR*.

Setting ( )	Description
0...[Max PID feedback] <i>P1F2</i>	Setting range <b>Factory setting: 0,0 Hz</b>

**[OutletPres Assign] P52A ★**

Outlet pressure sensor assignment.

This parameter can be accessed if [Wake Up Mode] *WUP* is set to [Pressure] *LP*.

Setting	Code / Value	Description
[Not Configured]	<i>no</i>	Not assigned <b>Factory setting</b>
[AI1]...[AI3]	<i>A11</i> ... <i>A13</i>	Analog input AI1...AI3
[AI4]...[AI5]	<i>A14</i> ... <i>A15</i>	Analog input AI4...AI5 if VW3A3203 I/O extension module has been inserted
[AI Virtual 1]	<i>A1V1</i>	Virtual analogic input 1

## [AI1 Sensor config.] $W \square R \ I$ - Menu

### Access

[Complete settings] → [Pump functions] → [Sleep/wakeup] → [Wake up menu] → [AI1 Sensor config.]

### About This Menu

This menu can be accessed if:

- [OutletPres Assign]  $P \ S \ 2 \ R$  is set to [AI1]  $R \ , \ I$ , and
- [Wake Up Mode]  $W \ U \ P \ \Pi$  is set to [Pressure]  $L \ P$ .

### [AI1 Type] $R \ , \ I \ E$

Configuration of analog input AI1.

Setting	Code / Value	Description
[Voltage]	$I \ 0 \ \mu$	0-10 Vdc <b>Factory setting</b>
[Current]	$0 \ R$	0-20 mA

### [AI1 min value] $\mu \ , \ L \ \star$

AI1 voltage scaling parameter of 0%.

This parameter can be accessed if [AI1 Type]  $R \ , \ I \ E$  is set to [Voltage]  $I \ 0 \ \mu$ .

Setting	Description
0.0...10.0 Vdc	Setting range <b>Factory setting:</b> 0.0 Vdc

### [AI1 max value] $\mu \ , \ H \ \star$

AI1 voltage scaling parameter of 100%.

This parameter can be accessed if [AI1 Type]  $R \ , \ I \ E$  is set to [Voltage]  $I \ 0 \ \mu$ .

Setting	Description
0.0...10.0 Vdc	Setting range <b>Factory setting:</b> 10.0 Vdc

### [AI1 min. value] $C \ r \ L \ \star$

AI1 current scaling parameter of 0%.

This parameter can be accessed if [AI1 Type]  $R \ , \ I \ E$  is set to [Current]  $0 \ R$ .

Setting	Description
0.0...20.0 mA	Setting range <b>Factory setting:</b> 0.0 mA

### [AI1 max. value] $C \ r \ H \ \star$

AI1 current scaling parameter of 100%.

This parameter can be accessed if [AI1 Type]  $R \ , \ I \ E$  is set to [Current]  $0 \ R$ .

Setting	Description
0.0...20.0 mA	Setting range <b>Factory setting:</b> 20.0 mA

**[A11 Lowest Process] R , I J**

A11 lowest process.

Setting	Description
-32,768...32,767	Setting range. Value in application customer unit. <b>Factory setting:</b> 0

**[A11 Highest Process] R , I K**

A11 highest process.

Setting	Description
-32,768...32,767	Setting range. Value in application customer unit. <b>Factory setting:</b> 0

## [AI2 Sensor config.] W O R 2 - Menu

### Access

[Complete settings] → [Pump functions] → [Sleep/wakeup] → [Wake up menu] → [AI2 Sensor config.]

### About This Menu

This menu can be accessed if:

- [OutletPres Assign] P S 2 R is set to [AI2] R , 2 , and
- [Wake Up Mode] W U P M is set to [Pressure] L P .

### [AI2 Type] R , 2 E

Configuration of analog input AI2.

Setting	Code / Value	Description
[Voltage]	1 0 V	0-10 Vdc <b>Factory setting</b>
[Current]	0 A	0-20 mA
[PTC Management]	P E C	1 to 6 PTC (in serial)
[KTY]	K E Y	1 KTY84
[PT1000]	1 P E 3	1 PT1000 connected with 2 wires
[PT100]	1 P E 2	1 PT100 connected with 2 wires
[Water Prob]	L E U E L	Water level
[3PT1000]	3 P E 3	3 PT1000 connected with 2 wires
[3PT100]	3 P E 2	3 PT100 connected with 2 wires

### [AI2 min value] V , L 2 ★

AI2 voltage scaling parameter of 0%.

This parameter can be accessed if [AI2 Type] R , 2 E is set to [Voltage] 1 0 V .

Identical to [AI1 min value] V , L 1 (see page 355).

### [AI2 max value] V , H 2 ★

AI2 voltage scaling parameter of 100%.

This parameter can be accessed if [AI2 Type] R , 2 E is set to [Voltage] 1 0 V .

Identical to [AI1 max value] V , H 1 (see page 355).

### [AI2 min. value] C r L 2 ★

AI2 current scaling parameter of 0%.

This parameter can be accessed if [AI2 Type] R , 2 E is set to [Current] 0 A .

Identical to [AI1 min. value] C r L 1 (see page 355).

### [AI2 max. value] C r H 2 ★

AI2 current scaling parameter of 100%.

This parameter can be accessed if [AI2 Type] R , 2 E is set to [Current] 0 A .

Identical to [AI1 max. value] C r H 1 (see page 355).

**[AI2 Lowest Process] R , 2 J**

AI2 lowest process.

Identical to **[AI1 Lowest Process] R , 1 J** (*see page 356*).

**[AI2 Highest Process] R , 2 K**

AI2 highest process.

Identical to **[AI1 Highest Process] R , 1 K** (*see page 356*).

## [AI3 Sensor config.] W 0 R 3 - Menu

### Access

[Complete settings] → [Pump functions] → [Sleep/wakeup] → [Wake up menu] → [AI3 Sensor config.]

### About This Menu

This menu can be accessed if:

- [OutletPres Assign] P 5 2 R is set to [AI3] R , 3, and
- [Wake Up Mode] W 0 P 11 is set to [Pressure] L P.

### [AI3 Type] R , 3 E

Configuration of analog input AI3.

Identical to [AI2 Type] R , 2 E (see page 357) with factory setting: [Current] 0 R.

### [AI3 min value] 0 , L 3 ★

AI3 voltage scaling parameter of 0%.

This parameter can be accessed if R , 3 E is set to [Voltage] 1 0 0.

Identical to [AI1 min value] 0 , L 1 (see page 355).

### [AI3 max value] 0 , H 3 ★

AI3 voltage scaling parameter of 100%.

This parameter can be accessed if R , 3 E is set to [Voltage] 1 0 0.

Identical to [AI1 max value] 0 , H 1 (see page 355).

### [AI3 min. value] C r L 3 ★

AI3 current scaling parameter of 0%.

This parameter can be accessed if R , 3 E is set to [Current] 0 R.

Identical to [AI1 min. value] C r L 1 (see page 355).

### [AI3 max. value] C r H 3 ★

AI3 current scaling parameter of 100%.

This parameter can be accessed if R , 3 E is set to [Current] 0 R.

Identical to [AI1 max. value] C r H 1 (see page 355).

### [AI3 Lowest Process] R , 3 J

AI3 lowest process.

Identical to [AI1 Lowest Process] R , 1 J (see page 356).

### [AI3 Highest Process] R , 3 K

AI3 highest process.

Identical to [AI1 Highest Process] R , 1 K (see page 356).

## [AI4 Sensor config.] W 0 R 4 - Menu

### Access

[Complete settings] → [Pump functions] → [Sleep/wakeup] → [Wake up menu] → [AI4 Sensor config.]

### About This Menu

This menu can be accessed if:

- [OutletPres Assign] P 5 2 R is set to [AI4] R , 4, and
- [Wake Up Mode] W 0 P 11 is set to [Pressure] L P.

### [AI4 Type] R , 4 E ★

Configuration of analog input AI4.

This parameter can be accessed if VW3A3203 I/O extension module has been inserted.

Setting	Code / Value	Description
[Voltage]	1 0 0	0-10 Vdc
[Current]	0 R	0-20 mA
[Voltage +/-]	n 1 0 0	-10/+10 Vdc <b>Factory setting</b>
[PTC Management]	P E C	1 to 6 PTC (in serial)
[KTY]	K E Y	1 KTY84
[PT1000]	1 P E 3	1 PT1000 connected with 2 wires
[PT100]	1 P E 2	1 PT100 connected with 2 wires
[3 PT1000]	3 P E 3	3 PT1000 connected with 2 wires
[3 PT100]	3 P E 2	3 PT100 connected with 2 wires
[PT1000 in 3 wires]	1 P E 3 3	1 PT1000 connected with 3 wires (AI4 & AI5 only)
[PT100 in 3 wires]	1 P E 2 3	1 PT100 connected with 3 wires (AI4 & AI5 only)
[3 PT1000 in 3 wires]	3 P E 3 3	3 PT1000 connected with 3 wires (AI4 & AI5 only)
[3 PT100 in 3 wires]	3 P E 2 3	3 PT100 connected with 3 wires (AI4 & AI5 only)

### [AI4 min value] 0 , L 4 ★

AI4 voltage scaling parameter of 0%.

Identical to [AI1 min value] 0 , L 1 (see page 355).

### [AI4 max value] 0 , H 4 ★

AI4 voltage scaling parameter of 100%.

Identical to [AI1 max value] 0 , H 1 (see page 355).

### [AI4 min. value] C r L 4 ★

AI4 current scaling parameter of 0%.

Identical to [AI1 min. value] C r L 1 (see page 355).

### [AI4 max. value] C r H 4 ★

AI4 current scaling parameter of 100%.

Identical to [AI1 max. value] C r H 1 (see page 355).



**[AI4 Lowest Process] R , 4 J**

AI4 lowest process.

Identical to **[AI1 Lowest Process] R , 1 J** (*see page 356*).

**[AI4 Highest Process] R , 4 K**

AI4 highest process.

Identical to **[AI1 Highest Process] R , 1 K** (*see page 356*).

## [AI5 Sensor config.] W 0 R 5 - Menu

### Access

[Complete settings] → [Pump functions] → [Sleep/wakeup] → [Wake up menu] → [AI5 Sensor config.]

### About This Menu

This menu can be accessed if:

- [OutletPres Assign] P 5 2 R is set to [AI5] R , 5 , and
- [Wake Up Mode] W 0 P 11 is set to [Pressure] L P .

### [AI5 Type] R , 5 E ★

Configuration of analog input AI5.

This parameter can be accessed if VW3A3203 relay output option module has been inserted.

Identical to [AI4 Type] R , 4 E (see page 360).

### [AI5 min value] 0 , L 5 ★

AI5 voltage scaling parameter of 0%.

Identical to [AI1 min value] 0 , L 1 (see page 355).

### [AI5 max value] 0 , H 5 ★

AI5 voltage scaling parameter of 100%.

Identical to [AI1 max value] 0 , H 1 (see page 355).

### [AI5 min. value] C r L 5 ★

AI5 current scaling parameter of 0%.

Identical to [AI1 min. value] C r L 1 (see page 355).

### [AI5 max. value] C r H 5 ★

AI5 current scaling parameter of 100%.

Identical to [AI1 max. value] C r H 1 (see page 355).

### [AI5 Lowest Process] R , 5 J

AI5 lowest process.

Identical to [AI1 Lowest Process] R , 1 J (see page 356).

### [AI5 Highest Process] R , 5 K

AI5 highest process.

Identical to [AI1 Highest Process] R , 1 K (see page 356).

## [AIV1 Sensor config.] W 0 V / - Menu

### Access

[Complete settings] → [Pump functions] → [Sleep/wakeup] → [Wake up menu] → [AIV1 Sensor config.]

### About This Menu

This menu can be accessed if:

- [OutletPres Assign] P 5 2 A is set to [AI Virtual 1] A , V I, and
- [Wake Up Mode] W 0 P 0 is set to [Pressure] L P.

### [AIV1 Channel Assignment] A , C I

Channel assignment for virtual analog input AIV1.

Setting	Code / Value	Description
[Not Configured]	n o	Not assigned <b>Factory setting</b>
[Ref. Freq-Modbus]	0 d b	Reference frequency via Modbus
[Ref. Freq-CANopen]	C A n	Reference frequency via CANopen if a CANopen module has been inserted
[Ref. Freq-Com. Module]	n E t	Reference frequency via fieldbus module if a fieldbus module has been inserted
[Embedded Ethernet]	E t H	Embedded Ethernet

### [AIV1 Lowest Process] A 0 I J

AI virtual x: minimum process value.

Setting	Description
-32,767...32,767	Setting range <b>Factory setting: 0</b>

### [AIV1 Highest Process] A 0 I K

AI virtual x: maximum process value.

Setting	Description
-32,767...32,767	Setting range <b>Factory setting: 0</b>

**[Wake up menu] WK P - Menu****Access**

[Complete settings] → [Pump functions] → [Sleep/wakeup] → [Wake up menu]

**About This Menu**

This menu can be accessed if [Sleep Detect Mode] SL P Π is not set to [Not Configured] n o.

**[Wake Up Press Level] W U P L ★**

Wake-up pressure level.

Pressure level over which the system should leave the sleep mode.

This parameter can be accessed if [Wake Up Mode] W U P Π is set to [Pressure] L P.

Setting ( )	Description
[No] n o to 32,767	Setting range Unit: [P sensor unit] S U P r (for example, Pa, Bar, PSI, %) Factory setting: [No] n o

## Section 7.11

### [Pump functions] - [Feedback monitoring]

#### [Feedback monitoring] F K Π - Menu

##### Access

[Complete settings] → [Pump functions] → [Feedback monitoring]

##### About This Menu

The function is typically used to detect cases where the installation capability is exceeded or where the installation is not operating properly:

- Fire hydrant opened.
- Pump start-up with open discharge valve.
- Mechanical breakdown of pipes.
- Water leakage.

When the drive is running at high speed, this function monitors the PID feedback in order to detect if it is out of a given range around the setpoint during a configurable time.

By using a warning or a detected error, this function also indicates that:

- The capability of the installation is exceeded
- The proper control could not be ensured
- Something is wrong on the installation.

This graphic presents the PID feedback monitoring:

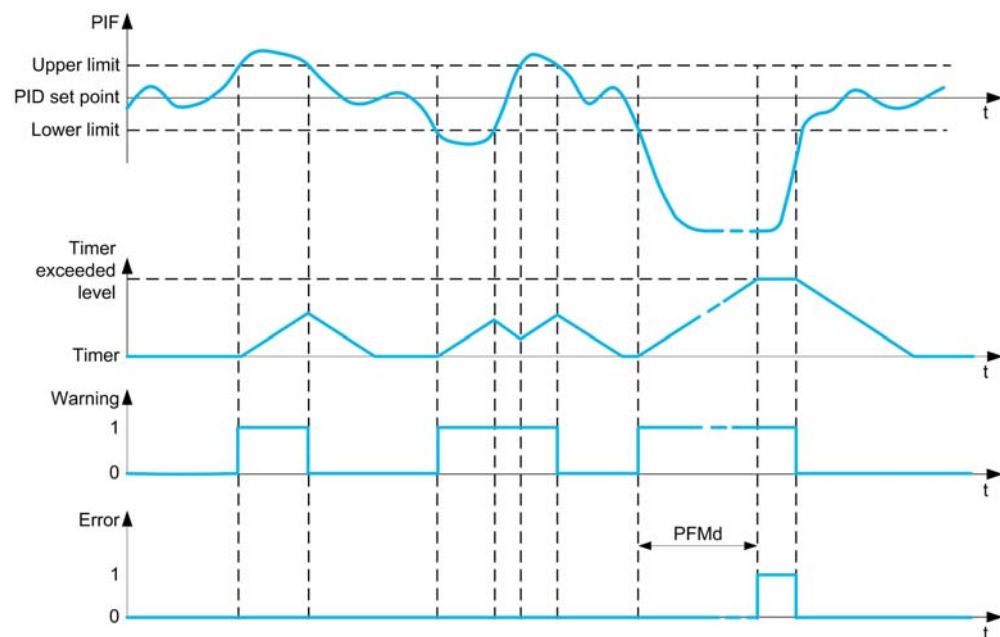

#### [PID Fdbk Monitoring] P F Π Π

PID feedback monitoring mode.

Parameter used to activate the function.

Setting	Code / Value	Description
[No]	0 0	No <b>Factory setting</b>
[YES]	5 5	Yes

**[PID Fdbk Range] P F Π r ★**

PID feedback monitoring range.

Range within which the PID feedback value is supposed to stay in normal situation.

This parameter can be accessed if **[PID Fdbk Monitoring] P F Π Π** is not set to **[No] n o**.

Setting ( )	Description
0...100%	Setting range <b>Factory setting:</b> 3%

**[PID Fdbk Error Delay] P F Π d ★**

PID feedback monitoring delay.

Delay to trig an error after detection of an anomaly.

This parameter can be accessed if **[PID Fdbk Monitoring] P F Π Π** is not set to **[No] n o**.

Setting ( )	Description
0...3,600 s	Setting range <b>Factory setting:</b> 10 s

**[PID Fdbk Error Resp] P F Π b ★**

PID feedback monitoring response to a detected error.

Define how the drive reacts when a feedback monitoring error occurs.

This parameter can be accessed if **[PID Fdbk Monitoring] P F Π Π** is not set to **[No] n o**.

Setting	Code / Value	Description
<b>[Ignore]</b>	n o	Detected error ignored
<b>[Freewheel Stop]</b>	Y E 5	Freewheel stop
<b>[Per STT]</b>	S E E	Stop according to <b>[Type of stop] S E E</b> parameter but without an error triggered after stop
<b>[Fallback Speed]</b>	L F F	Change to fallback speed, maintained as long as the detected error persists and the run command has not been removed <sup>(1)</sup>
<b>[Ramp stop]</b>	r Π P	Stop on ramp <b>Factory setting</b>
<b>1</b> Because, in this case, the detected error does not trigger a stop, it is recommended to assign a relay or logic output to its indication.		

## Section 7.12

### [Pump functions] - [Pump characteristics]

#### [Pump characteristics] P C r - Menu

##### Access

[Complete settings] → [Pump functions] → [Pump characteristics]

##### About This Menu

Centrifugal pump characteristic allows you to define the curve points for:

- Head
- Mechanical power
- Efficiency

The pump manufacture supplies these elements and it is necessary to define the performances of a pump at a given speed.

Pump data is characterized in several points and for a given speed (typically nominal speed):

- Speed (N) used for characterization: typically nominal speed.
- Flow (Q) on each characteristic point.
- Head (H) on each characteristic point.
- Power (P) on each characteristic point.

Example for simplified pump data curves:

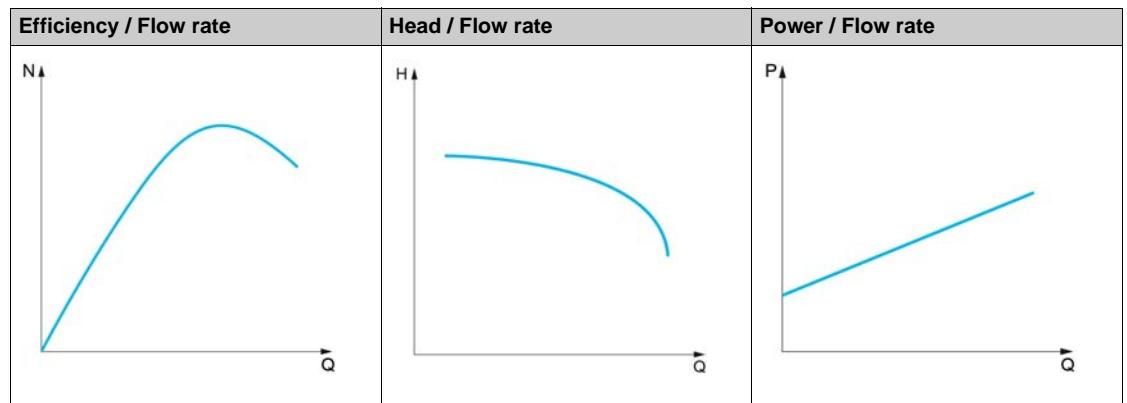

This function allows to:

- interpolate the curves at a given speed, thus minimizing interpolation errors,
- interpolate the curves for other pump speeds using affinity motor control types.

**Use-case**

Several functions need **[HQ] H Q** or **[PQ] P Q** curves before being used.  
Monitoring of pump working point on pump curve:

Use-case	Characterized Pump Data (vs. pump speed)	
	HQ	PQ
"Head vs Flow" curve	X	
"Power vs Flow" curve		X
"Power vs Speed" (fixed Q values)		X

Sensorless flow estimation:

Use-case	Characterized Pump Data (vs. pump speed)	
	HQ	PQ
Estimation of flow from head	X	
Estimation of flow from power		X

**Function Activation**

To activate this function, set **[Mode] P C N** to **[HQ] H Q** or **[PQ] P Q** or **[PHQ] P H Q**. It depends on the data you enter.

After entering all the data (curve + BEP), set **[Pump Curve Activate] P C A** to **[YES] Y E S**.

**Curve Setting**

The entering points should be spaced as evenly as possible over the operating range for the given speed:

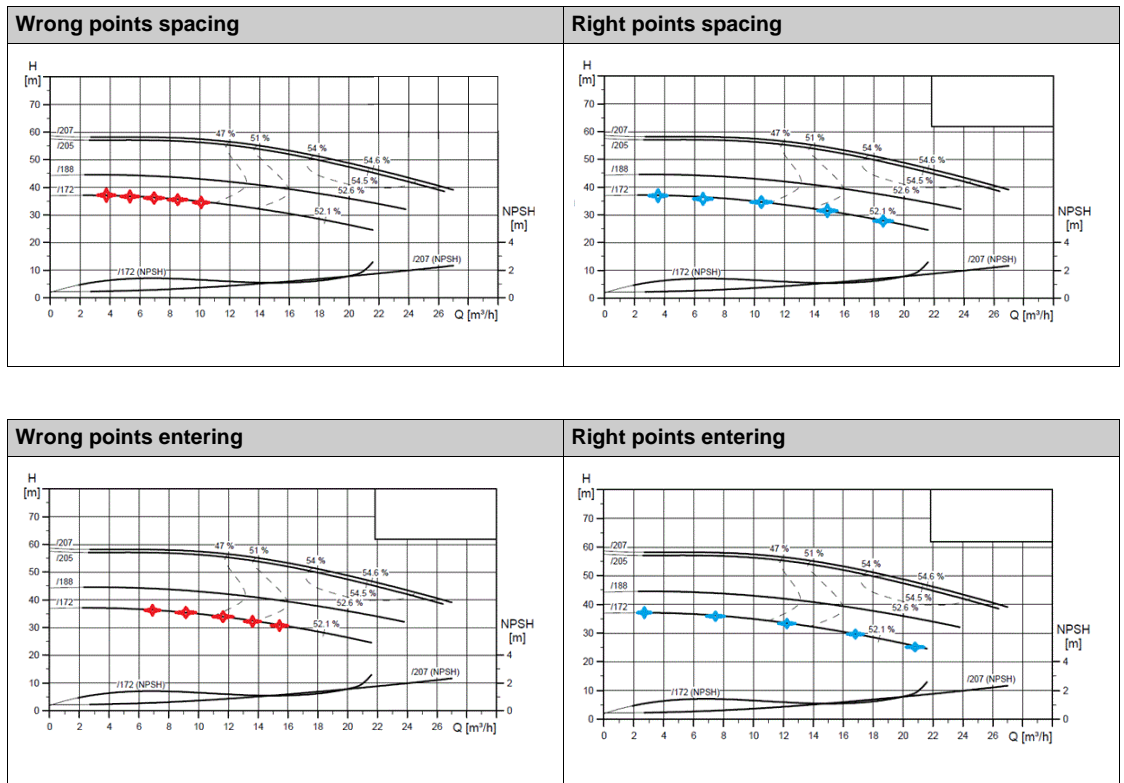

For **[HQ] H Q** or **[PQ] P Q** curves, 5 points are advised:

- Q1 near the zero flow point.
- Q3 near the BEP point.
- Q5 near the zero head point.
- Q2 equidistant between Q1 and Q3.
- Q4 equidistant between Q3 and Q5.



### Configuration of Best Efficiency Point (BEP)

The configuration of BEP allows you to display this on  $H Q$ ,  $P Q$  and  $E Q$  curve:

- Pump curve flow rate at BEP: **[Flow at BEP] P C b Q**.
- Pump curve head at BEP: **[Head BEP] P C b H**.
- Pump curve power at BEP: **[Power BEP] P C b P**.

This graphic represents the curve and the BEP:

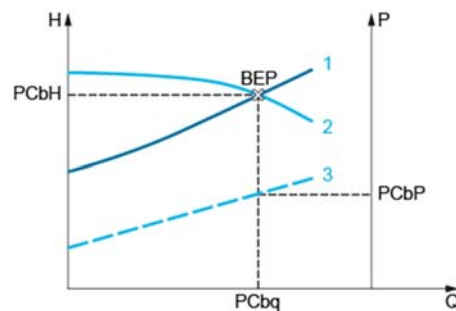

- 1 System curve
- 2 Pump  $H Q$  curve
- 3 Pump  $P Q$  curve

### [Mode] P C $\Pi$

Pump curve mode.

Select which curve data are managed and is entered on.

Setting	Code / Value	Description
[No]	$n o$	Function is not activated <b>Factory setting</b>
[HQ]	$H Q$	H, Q data is activated
[PQ]	$P Q$	P, Q data is activated
[PHQ]	$P H Q$	P, H, Q data is activated

### [Pump Flow Assign.] F S $\mathcal{P}$ A ★

Pump flow sensor assignment.

This parameter can be accessed if **[PumpLF Monitoring] P L F  $\Pi$**  is set to **[Flow] Q** or to **[Flow vs Speed] Q n**.

Setting	Code / Value	Description
[Not Configured]	$n o$	Not assigned <b>Factory setting</b>
[AI1]...[AI3]	$A , 1 \dots A , 3$	Analog input AI1...AI3
[AI4]...[AI5]	$A , 4 \dots A , 5$	Analog input AI4...AI5 if VW3A3203 I/O extension module has been inserted
[AI Virtual 1]	$A , V 1$	Virtual analogic input 1
[PulseInput Assignment On DI5]...[PulseInput Assignment On DI6]	$P , 5 \dots P , 6$	Digital input DI5...DI6 used as pulse input
[Flow Estimation]	$S L P F$	Sensor less estimated flow

**[Pump Curve Activate] P C A ★**

Pump curve activation.

Parameter used to reset or validate data to be used by other functions.

This parameter can be accessed if **[Mode] P C Π** is not set to **[No] n o**.

Setting	Code / Value	Description
<b>[No]</b>	<i>n o</i>	Pump characteristics are deactivated and data can be modified <b>Factory setting</b>
<b>[YES]</b>	<i>Y E S</i>	Ask for pump characteristic activation. If it does not succeed, write back NO; else lock data modification

**[Status] P C S ★**

Pump curve status.

This parameter can be accessed if **[Mode] P C Π** is not set to **[No] n o**.

Setting	Code / Value	Description
<b>[None]</b>	<i>n o n E</i>	Function is not configured <b>Factory setting</b>
<b>[INACTIVE]</b>	<i>n A C t</i>	Function is configured but inactive (data is unlocked)
<b>[ACTIVE]</b>	<i>A C t i V E</i>	Data is activated and can be used for other functions (data is locked)
<b>[FAILED]</b>	<i>F A i L E d</i>	Data activation does not succeed (some points have not been entered or data entered does not comply with the rules)

**[Pump Speed] P C S P ★**

Pump speed for which curves are entered.

This parameter can be accessed if **[Mode] P C Π** is not set to **[No] n o**.

Setting	Description
0...32,767 rpm	Setting range <b>Factory setting:</b> 0 rpm

**[Flow at BEP] P C b q ★**

Pump curve flow rate at BEP.

This parameter can be accessed if **[Mode] P C Π** is not set to **[No] n o**.

Setting ( )	Description
0...32,767	Setting range according to <b>[Flow rate unit] S u F r</b> <b>Factory setting:</b> 0

**[Head BEP] P C b H ★**

Pump curve head at BEP.

This parameter can be accessed if **[Mode] P C Π** is not set to **[No] n o**.

Setting ( )	Description
0...32,767	Setting range according to <b>[P sensor unit] S u P r</b> <b>Factory setting:</b> 0

**[Power BEP] P C b P ★**

Pump curve power at BEP.

This parameter can be accessed if **[Mode] P C Π** is not set to **[No] n o**.

Setting ( )	Description
0...32,767	Setting range according to <b>[Motor Standard] b F r</b> <b>Factory setting: 0</b>

**[Flow 1] P C q 1 ★**

Pump curve flow rate for point 1.

Flow rate entered at point 1 (for HQ and PQ curves).

This parameter can be accessed if **[Mode] P C Π** is not set to **[No] n o**.

Setting ( )	Description
0...32,767	Setting range according to <b>[Flow rate unit] S u F r</b> <b>Factory setting: 0</b>

**[Head 1] P C H 1 ★**

Pump curve head for point 1.

Head entered at point 1 (for HQ curve).

This parameter can be accessed if **[Mode] P C Π** is set to **[HQ] H q** or **[PHQ] P H q**.

Setting ( )	Description
0...32,767	Setting range according to <b>[P sensor unit] S u P r</b> <b>Factory setting: 0</b>

**[Power 1] P C P 1 ★**

Pump curve power for point 1.

Mechanical power entered at point 1 (for PQ curve).

This parameter can be accessed if **[Mode] P C Π** is set to **[PQ] P q** or **[PHQ] P H q**.

Setting ( )	Description
0...32,767	Setting range according to <b>[Motor Standard] b F r</b> <b>Factory setting: 0</b>

**[Flow 2] P C q 2 ★**

Pump curve flow rate for point 2.

Flow rate entered at point 2 (for HQ and PQ curves).

This parameter can be accessed if **[Mode] P C Π** is not set to **[No] n o**.

Setting ( )	Description
0...32,767	Setting range according to <b>[Flow rate unit] S u F r</b> <b>Factory setting: 0</b>

**[Head 2] PCH2★**

Pump curve head for point 2.

Head entered at point 2 (for HQ curve).

Setting ( )	Description
0...32,767	Setting range according to <b>[P sensor unit] S u P r</b> <b>Factory setting: 0</b>

**[Power 2] PCP2★**

Pump curve power for point 2.

Mechanical power entered at point 2 (for PQ curve).

This parameter can be accessed if **[Mode] P C Π** is set to **[PQ] P 9** or **[PHQ] P H 9**.

Setting ( )	Description
0...32,767	Setting range according to <b>[Motor Standard] b F r</b> <b>Factory setting: 0</b>

**[Flow 3] PCH3★**

Pump curve flow rate for point 3.

Flow rate entered at point 3 (for HQ and PQ curves).

This parameter can be accessed if **[Mode] P C Π** is not set to **[No] n o**.

Setting ( )	Description
0...32,767	Setting range according to <b>[Flow rate unit] S u F r</b> <b>Factory setting: 0</b>

**[Head 3] PCH3★**

Pump curve head for point 3.

Head entered at point 3 (for HQ curve).

This parameter can be accessed if **[Mode] P C Π** is set to **[HQ] H 9** or **[PHQ] P H 9**.

Setting ( )	Description
0...32,767	Setting range according to <b>[P sensor unit] S u P r</b> <b>Factory setting: 0</b>

**[Power 3] PCP3★**

Pump curve power for point 3.

Mechanical power entered at point 3 (for PQ curve).

This parameter can be accessed if **[Mode] P C Π** is set to **[PQ] P 9** or **[PHQ] P H 9**.

Setting ( )	Description
0...32,767	Setting range according to <b>[Motor Standard] b F r</b> <b>Factory setting: 0</b>

**[Flow 4] P C 9 4 ★**

Pump curve flow rate for point 4.

Flow rate entered at point 4 (for HQ and PQ curves).

This parameter can be accessed if **[Mode] P C Π** is not set to **[No] n o .**

Setting ( )	Description
0...32,767	Setting range according to <b>[Flow rate unit] S u F r</b> <b>Factory setting:</b> 0

**[Head 4] P C H 4 ★**

Pump curve head for point 4.

Head entered at point 4 (for HQ curve).

This parameter ca be accessed if **[Mode] P C Π** is set to **[HQ] H 9** or **[PHQ] P H 9**.

Setting ( )	Description
0...32,767	Setting range according to <b>[P sensor unit] S u P r</b> <b>Factory setting:</b> 0

**[Power 4] P C P 4 ★**

Pump curve power for point 4.

Mechanical power entered at point 4 (for PQ curve).

This parameter ca be accessed if **[Mode] P C Π** is set to **[PQ] P 9** or **[PHQ] P H 9**.

Setting ( )	Description
0...32,767	Setting range according to <b>[Motor Standard] b F r</b> <b>Factory setting:</b> 0

**[Flow 5] P C 9 5 ★**

Pump curve flow rate for point 5.

Flow rate entered at point 5 (for HQ and PQ curves).

This parameter can be accessed if **[Mode] P C Π** is not set to **[No] n o .**

Setting ( )	Description
0...32,767	Setting range according to <b>[Flow rate unit] S u F r</b> <b>Factory setting:</b> 0

**[Head 5] P C H 5 ★**

Pump curve head for point 5.

Head entered at point 5 (for HQ curve).

This parameter ca be accessed if **[Mode] P C Π** is set to **[HQ] H 9** or **[PHQ] P H 9**.

Setting ( )	Description
0...32,767	Setting range according to <b>[P sensor unit] S u P r</b> <b>Factory setting:</b> 0

**[Power 5] P C P 5 ★**

Pump curve power for point 5.

Mechanical power entered at point 5 (for PQ curve).

This parameter can be accessed if **[Mode] P C Π** is set to **[PQ] P 9** or **[PHQ] P H 9**.

Setting ( )	Description
0...32,767	Setting range according to <b>[Motor Standard] b F r</b> <b>Factory setting:</b> 0

**[Head Static Offset] H E □ ★**

Head static offset.

This parameter can be accessed if **[Flow Estimation Mode] F E Π** is set to **[HQ] H 9**.

Setting ( )	Description
0.0...100.0%	Setting range <b>Factory setting:</b> 0.0%

**[Head Dynamic Gain] H E □ ★**

Head dynamic gain.

This parameter can be accessed if **[Flow Estimation Mode] F E Π** is set to **[HQ] H 9**.

Setting ( )	Description
-100.0...100.0%	Setting range <b>Factory setting:</b> 0.0%

**[Head Estimated] S L H □**

Head estimation: Value.

Setting ( )	Description
-32,767...32,767	Setting range according to <b>[P sensor unit] S □ P r</b> <b>Factory setting:</b> 0

## Section 7.13

### [Pump functions] - [Sensorless flow estimation]

#### [Sensorless flow estimation] SFE - Menu

##### Access

[Complete settings] → [Pump functions] → [Sensorless flow estimation]

##### About This Menu

This function allows the estimation of the flow of the pump using the predefined pump curves HQ or PQ set in the pump characteristics.

The PQ curve shall be used if there is no pressure sensor on the system.

The HQ curve shall be used if inlet and/or outlet pressure feedbacks are available (or a differential value).

The curves shall be set in the pump characteristic functions before setting the sensorless flow estimation function.

The figure below shows the calculating area (1) using the HQ curve.

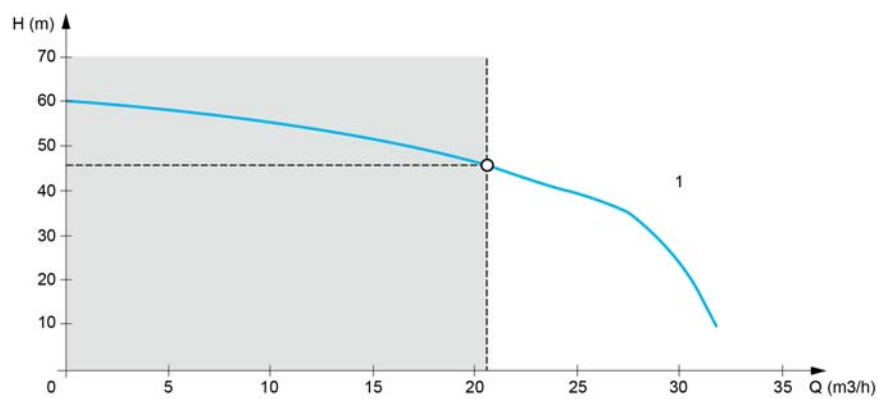

The figure below shows the calculating area (2) using the PQ curve.

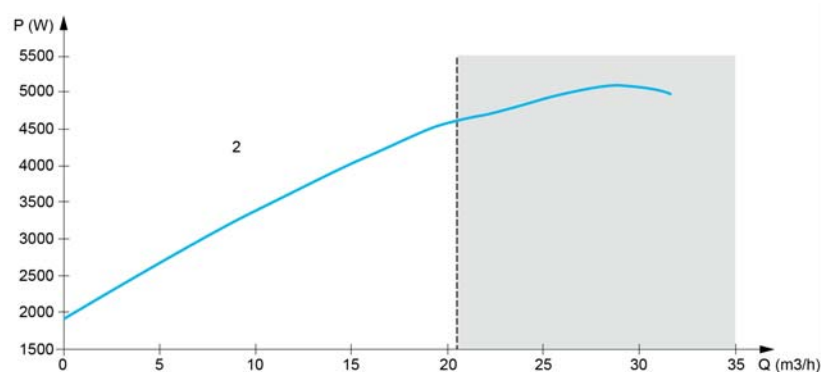

Using the PQ curve, it is necessary to calibrate the function with:

- **[Power Dynamic Gain] PEG** to define a correction gain applied to the estimated power from the drive
- **[Power Static Offset] PEO** to define a correction offset applied to the estimated power from the drive
- **[Liquid Density] rHD** is the density of the fluid to be pumped

Using the HQ curve, it is necessary to enter the data related to the application:

- **[Liquid Density] rHD** is the density of the fluid to be pumped
- **[Head Dynamic Gain] HEG** is the correction gain, modeling the dynamical head losses between the two pressure sensors
- **[Head Static Offset] HEO** is a correction offset applied to the head provided by the pump

**[Flow Estimation Mode] F E Π**

Flow estimation mode.

Setting	Code / Value	Description
[No]	n 0	Function not activated <b>Factory setting</b>
[HQ]	H 9	H, Q data is activated
[PQ]	P 9	P, Q data is activated

**[Head Dynamic Gain] H E G ★**

Head dynamic gain.

This parameter can be accessed if **[Flow Estimation Mode] F E Π** is set to **[HQ] H 9**.

Setting ( )	Description
-100.0...100.0%	Setting range <b>Factory setting:</b> 0.0%

**[Head Static Offset] H E 0 ★**

Head static offset.

This parameter can be accessed if **[Flow Estimation Mode] F E Π** is set to **[HQ] H 9**.

Setting ( )	Description
-100.0...100.0%	Setting range <b>Factory setting:</b> 0.0%

**[Power Dynamic Gain] P E G ★**

Power dynamic gain.

This parameter can be accessed if **[Flow Estimation Mode] F E Π** is set to **[PQ] P 9**.

Setting ( )	Description
-100.0...100.0%	Setting range <b>Factory setting:</b> 0.0%

**[Power Static Offset] P E 0 ★**

Power static offset.

This parameter can be accessed if **[Flow Estimation Mode] F E Π** is set to **[PQ] P 9**.

Setting ( )	Description
-100.0...100.0%	Setting range <b>Factory setting:</b> 0.0%

**[Pump Flow] F 5 2 0**

Pump flow sensor value.

Setting ( )	Description
-32,767...32,767	Setting range <b>Factory setting:</b> -



**[Flow Estimated]** *S L F U* ★

Estimated flow value.

This parameter can be accessed if **[Flow Estimation Mode]** *F E M* is not set to **[No]** *n o*

Setting (i)	Description
Value in application customer unit	Setting range Factory setting: -

# Section 7.14

## [Pump functions] - [Pump start stop]

### [Pump start stop] P S L - Menu

#### Access

[Complete settings] → [Pump functions] → [Pump start stop]

#### About This Menu

This function defines how the acceleration and deceleration are controlled during start and stop of the pump.

The pump working area is within the speed range [Low Speed] L S P - [High Speed] H S P.

The minimum speed is provided by the pump manufacturer according to the application.

Running below the minimum speed and/or starting the pump with a long acceleration ramp time has an impact on the lubrication of the seal, on the cooling of the impeller and the bearings.

A specific check-valve deceleration ramp is available to reduce any large variation of pressure that can generate an instability of the valve.

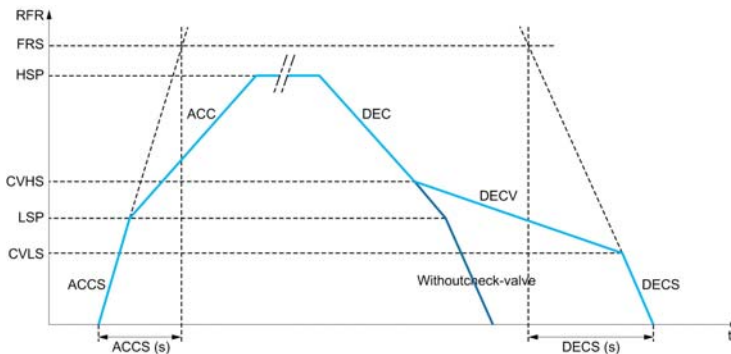

When the pump starts, the pump accelerates up to [Low Speed] L S P according to [Start Accel Ramp] R C C S. When the pump speed is above [Low Speed] L S P, the pump acceleration and deceleration are managed according to [Acceleration] R C C and [Deceleration] d E C if no other function is activated.

When the pump stops:

- The pump decelerates down to [Check Valve Spd 2] C V H S according to [Deceleration] d E C
- The pump decelerates from [Check Valve Spd 2] C V H S to [Check Valve Spd 1] C V L S according to [Dec. Check Valve] d E C V
- The pump decelerates from [Check Valve Spd 1] C V L S to zero speed according to [Deceleration on Stop] d E C S

If [Start Accel Ramp] R C C S = 0, the start ramp is ignored and [Acceleration] R C C is used to start the pump.

If [Dec. Check Valve] d E C V = 0, the check-valve ramp is ignored and is used to decelerate up to [Low Speed] L S P, then [Deceleration on Stop] d E C S is used (see below).

If [Deceleration on Stop] d E C S = 0, the normal deceleration [Deceleration] d E C is used to stop the pump.

#### [Low Speed] L S P

Motor frequency at low speed.

Setting ( )	Description
0...[High Speed] H S P	Setting range Factory setting: 0 Hz

**[High Speed] H 5 P**

Motor frequency at high speed.

Setting ( )	Description
[Low Speed] L 5 P...[Max Frequency] E F r	Setting range Factory setting: 50.0 Hz

**[Acceleration] A C C**

Time to accelerate from 0 to the [Nominal Motor Freq] F r 5.

To have repeatability in ramps, the value of this parameter must be set according to the possibility of the application.

Setting ( )	Description
0.00...6,000.00 s <sup>(1)</sup>	Setting range Factory setting: 10.00 s
(1) Range 0.00 to 99.99 s or 0.0 to 999.9 s or 0 to 6,000 according to [Ramp increment] i n r	

**[Deceleration] d E C**

Time to decelerate from the [Nominal Motor Freq] F r 5 to 0.

To have repeatability in ramps, the value of this parameter must be set according to the possibility of the application.

Setting ( )	Description
0.00...6,000.00 s <sup>(1)</sup>	Setting range Factory setting: 10.00 s
(1) Range 0.00 to 99.99 s or 0.0 to 999.9 s or 0 to 6,000 according to [Ramp increment] i n r	

**[Start Accel Ramp] A C C 5**

Acceleration on start.

Setting ( )	Description
[No] n o...6,000 s <sup>(1)</sup>	Setting range Factory setting: [No] n o
(1) Range 0.00 to 99.99 s or 0.0 to 999.9 s or 0 to 6,000 according to [Ramp increment] i n r	

**[Final Dec. Ramp] d E C 5**

Deceleration on stop.

Setting ( )	Description
[No] n o...6,000 s <sup>(1)</sup>	Setting range Factory setting: [No] n o
(1) Range 0.00 to 99.99 s or 0.0 to 999.9 s or 0 to 6,000 according to [Ramp increment] i n r	

**[Dec. Check Valve] d E C V**

Deceleration while check valve is closing (smooth).

Setting ( )	Description
[No] n o...6,000 s <sup>(1)</sup>	Setting range Factory setting: [No] n o
(1) Range 0.00 to 99.99 s or 0.0 to 999.9 s or 0 to 6,000 according to [Ramp increment] i n r	

**[Check Valve Spd 1] C V L 5 ★**

Speed level up to which check valve ramp is used.

This parameter can be accessed if **[Dec. Check Valve] d E C V** is not set to 0.

Setting ( )	Description
0... <b>[Check Valve Spd 2] C V H 5</b>	Setting range <b>Factory setting:</b> 0 Hz

**[Check Valve Spd 2] C V H 5 ★**

Speed level from which check valve ramp is used.

This parameter can be accessed if **[Dec. Check Valve] d E C V** is not set to 0.

Setting ( )	Description
<b>[Check Valve Spd 1] C V L 5...H 5 P</b>	Setting range <b>Factory setting:</b> 0 Hz

**[Ref Freq Template] b 5 P**

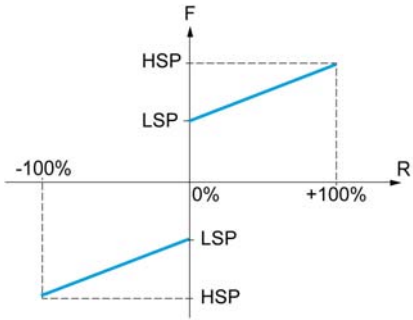
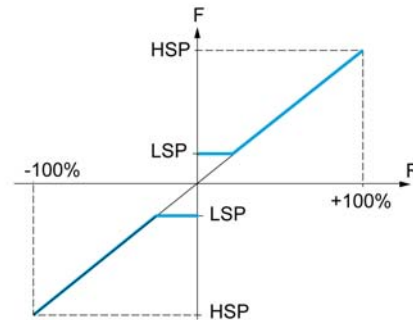
Setting ( )	Code / Value	Description
<b>[Standard]</b>	<b>b 5 d</b>	 <p><b>F</b> Frequency <b>R</b> Reference</p> <p>At zero reference the frequency = LSP <b>Factory setting</b></p>
<b>[Pedestal]</b>	<b>b L 5</b>	 <p><b>F</b> Frequency <b>R</b> Reference</p> <p>At reference = 0 to LSP the frequency = LSP</p>

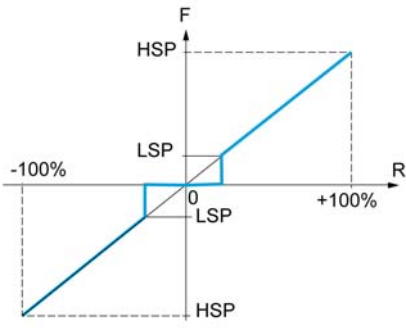
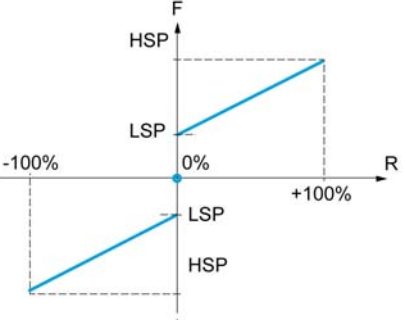
Setting ( )	Code / Value	Description
[Deadband]	<i>b n 5</i>	 <p><b>F</b> Frequency <b>R</b> Reference</p> <p>At reference = 0 to LSP the frequency = 0</p>
[Deadband 0]	<i>b n 5 0</i>	 <p><b>F</b> Frequency <b>R</b> Reference</p> <p>This operation is the same as <b>[Standard] b 5 d</b>, except that in the following cases at zero reference, the frequency = 0: The signal is less than <b>[Min nvalue]</b>, which is greater than 0 (example: 1 Vdc on a 2–10 Vdc input) The signal is greater than <b>[Min nvalue]</b>, which is greater than <b>[Max value]</b> (example: 11 Vdc on a 10–0 Vdc input). If the input range is configured as “bidirectional”, operation remains identical to <b>[Standard] b 5 d</b>. This parameter defines how the speed reference is taken into account, for analog inputs and pulse input only. In the case of the PID controller, this is the PID output reference. The limits are set by the <b>[Low speed] L 5 P</b> and <b>[High speed] H 5 P</b> parameters</p>

## Section 7.15

### [Pump functions] - [Pipe fill]

#### What Is in This Section?

This section contains the following topics:

Topic	Page
[Pipe fill] <i>PF 1</i> - Menu	383
[A11 configuration] <i>PF A 1</i> - Menu	385
[A12 configuration] <i>PF A 2</i> - Menu	387
[A13 configuration] <i>PF A 3</i> - Menu	389
[A14 configuration] <i>PF A 4</i> - Menu	390
[A15 configuration] <i>PF A 5</i> - Menu	392
[A1V1 configuration] <i>PF V 1</i> - Menu	393
[Pipe fill] <i>PF 1</i> - Menu	394

## [Pipe fill] $P F$ , - Menu

### Access

[Complete settings] → [Pump functions] → [Pipe fill]

### About This Menu

This menu can be accessed if:

- [Type of control]  $E O C E$  is set to [Pressure]  $P r E S S$ , and
- [PID feedback]  $P i F$  is not set to [No]  $n o$ .

The pipe fill function helps to prevent a water hammer effect from happening in the pipes when a system is filled in too quickly.

The function covers the horizontal pipe applications which are pressure-controlled by the PID function.

The pipe fill function can always be enabled or conditioned by a digital input (or a control bit in the I/O profile).

At the first start command in automatic mode, the system enters the pipe fill mode.

At next start commands, the drive will enter the pipe fill mode if the system pressure feedback is lower than [Pipe Fill Pressure]  $P F H P$ .

Each time the drive wakes-up, the drive enters the pipe fill mode if [Pipe Fill on Wake Up]  $P F W U$  is set to [Yes]  $Y E S$ .

The system remains in the horizontal pipe fill at [Pipe Fill Speed]  $P F H S$  speed until:

- the pressure feedback becomes greater than [Pipe Fill Pressure]  $P F H P$  parameter, or
- the system has been in the pipe fill for longer than [Pipe Fill Time]  $P F H T$  time.

If one of these conditions is met, the system enters the automatic pressure regulation mode.

**NOTE:** If [Pipe Fill Time]  $P F H T$  is set to 0, the system never enter the Pipe fill mode.

To set up this function, it is recommended to set both [Pipe Fill Speed]  $P F H S$  and [Pipe Fill Time]  $P F H T$  according to the maximum quantity of liquid to fill in the empty system.

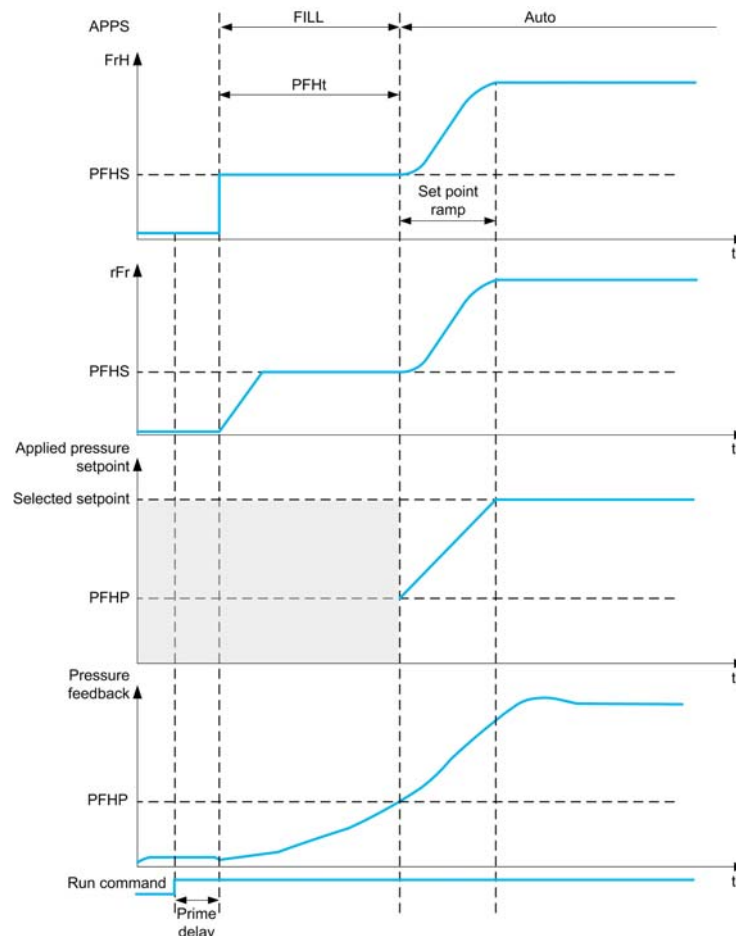

**[Activation Mode] P F Π**

Pipe fill activation mode.

Setting	Code / Value	Description
[No]	<i>n o</i>	Pipes fill disabled <b>Factory setting</b>
[Feedback]	<i>F b K</i>	Pipe fill on PID feedback
[Outlet Pressure]	<i>P 5 2</i>	Pipe fill on outlet pressure

**[OutletPres Assign] P 5 2 A ★**

Outlet pressure sensor assignment.

This parameter can be accessed if **[Activation Mode] P F Π** is set to **[Outlet Pressure] P 5 2**.

Setting	Code / Value	Description
[Not Configured]	<i>n o</i>	Not assigned <b>Factory setting</b>
[AI1]...[AI3]	<i>A , 1...A , 3</i>	Analog input AI1...AI3
[AI4]...[AI5]	<i>A , 4...A , 5</i>	Analog input AI4...AI5 if VW3A3203 I/O extension module has been inserted
[AI Virtual 1]	<i>A , V 1</i>	Virtual analogic input 1



## [AI1 configuration] P F R I - Menu

### Access

[Complete settings] → [Pump functions] → [Pipe fill] → [AI1 configuration]

### About This Menu

This menu can be accessed if:

- [Activation Mode] P F Π is set to [Outlet pressure] P 5 2, and
- [OutletPres Assign] P 5 2 R is set to [AI1] R , I .

### [AI1 Type] R , I E

Configuration of analog input AI1.

Setting	Code / Value	Description
[Voltage]	I D υ	0-10 Vdc <b>Factory setting</b>
[Current]	D R	0-20 mA

### [AI1 min value] υ , L I ★

AI1 voltage scaling parameter of 0%.

This parameter can be accessed if [AI1 Type] R , I E is set to [Voltage] I D υ .

Setting	Description
0.0...10.0 Vdc	Setting range <b>Factory setting:</b> 0.0 Vdc

### [AI1 max value] υ , H I ★

AI1 voltage scaling parameter of 100%.

This parameter can be accessed if [AI1 Type] R , I E is set to [Voltage] I D υ .

Setting	Description
0.0...10.0 Vdc	Setting range <b>Factory setting:</b> 10.0 Vdc

### [AI1 min. value] C r L I ★

AI1 current scaling parameter of 0%.

This parameter can be accessed if [AI1 Type] R , I E is set to [Current] D R .

Setting	Description
0.0...20.0 mA	Setting range <b>Factory setting:</b> 0.0 mA

### [AI1 max. value] C r H I ★

AI1 current scaling parameter of 100%.

This parameter can be accessed if [AI1 Type] R , I E is set to [Current] D R .

Setting	Description
0.0...20.0 mA	Setting range <b>Factory setting:</b> 20.0 mA

**[A11 Lowest Process] R , I J**

A11 lowest process.

Setting	Description
-32,767...32,767	Setting range. Value in application customer unit. <b>Factory setting:</b> 0

**[A11 Highest Process] R , I K**

A11 highest process.

Setting	Description
-32,767...32,767	Setting range. Value in application customer unit. <b>Factory setting:</b> 0

## [AI2 configuration] P F R 2 - Menu

### Access

[Complete settings] → [Pump functions] → [Pipe fill] → [AI2 configuration]

### About This Menu

This menu can be accessed if:

- [Activation Mode] P F Π is set to [Outlet pressure] P 5 2, and
- [OutletPres Assign] P 5 2 R is set to [AI2] R , 2 .

### [AI2 Type] R , 2 Ɛ

Configuration of analog input AI2.

Setting	Code / Value	Description
[Voltage]	1 0 Ʃ	0-10 Vdc <b>Factory setting</b>
[Current]	0 R	0-20 mA
[PTC Management]	P Ɛ Ɔ	1 to 6 PTC (in serial)
[KTY]	K Ɛ Ƴ	1 KTY84
[PT1000]	1 P Ɛ 3	1 PT1000 connected with 2 wires
[PT100]	1 P Ɛ 2	1 PT100 connected with 2 wires
[Water Prob]	L E Ʃ E L	Water level
[3PT1000]	3 P Ɛ 3	3 PT1000 connected with 2 wires
[3PT100]	3 P Ɛ 2	3 PT100 connected with 2 wires

### [AI2 min value] Ʃ , L 2 ★

AI2 voltage scaling parameter of 0%.

This parameter can be accessed if [AI2 Type] R , 2 Ɛ is set to [Voltage] 1 0 Ʃ.

Identical to [AI1 min value] Ʃ , L 1 (see page 385).

### [AI2 max value] Ʃ , H 2 ★

AI2 voltage scaling parameter of 100%.

This parameter can be accessed if [AI2 Type] R , 2 Ɛ is set to [Voltage] 1 0 Ʃ.

Identical to [AI1 max value] Ʃ , H 1 (see page 385).

### [AI2 min. value] Ɔ r L 2 ★

AI2 current scaling parameter of 0%.

This parameter can be accessed if [AI2 Type] R , 2 Ɛ is set to [Current] 0 R.

Identical to [AI1 min. value] Ɔ r L 1 (see page 385).

### [AI2 max. value] Ɔ r H 2 ★

AI2 current scaling parameter of 100%.

This parameter can be accessed if [AI2 Type] R , 2 Ɛ is set to [Current] 0 R.

Identical to [AI1 max. value] Ɔ r H 1 (see page 385).

**[AI2 Lowest Process] R , 2 J**

AI2 lowest process.

Identical to **[AI1 Lowest Process] R , 1 J** (*see page 386*).

**[AI2 Highest Process] R , 2 K**

AI2 highest process.

Identical to **[AI1 Highest Process] R , 1 K** (*see page 386*).

## [AI3 configuration] P F R 3 - Menu

### Access

[Complete settings] → [Pump functions] → [Pipe fill] → [AI3 configuration]

### About This Menu

This menu can be accessed if:

- [Activation Mode] P F 1 is set to [Outlet pressure] P 5 2, and
- [OutletPres Assign] P 5 2 R is set to [AI3] R , 3.

### [AI3 Type] R , 3 E

Configuration of analog input AI3.

Identical to [AI2 Type] R , 2 E with factory setting: [Current] 0 R (see page 387).

### [AI3 min value] 0 , L 3 ★

AI3 voltage scaling parameter of 0%.

This parameter can be accessed if [AI2 Type] R , 2 E is set to [Voltage] 1 0 0.

Identical to [AI1 min value] 0 , L 1 (see page 385).

### [AI3 max value] 0 , H 3 ★

AI3 voltage scaling parameter of 100%.

This parameter can be accessed if [AI3 Type] R , 3 E is set to [Voltage] 1 0 0.

Identical to [AI1 max value] 0 , H 1 (see page 385).

### [AI3 min. value] C r L 3 ★

AI3 current scaling parameter of 0%.

This parameter can be accessed if [AI3 Type] R , 3 E is set to [Current] 0 R.

Identical to [AI1 min. value] C r L 1 (see page 385).

### [AI3 max. value] C r H 3 ★

AI3 current scaling parameter of 100%.

This parameter can be accessed if [AI3 Type] R , 3 E is set to [Current] 0 R.

Identical to [AI1 max. value] C r H 1 (see page 385).

### [AI3 Lowest Process] R , 3 J

AI3 lowest process.

Identical to [AI1 Lowest Process] R , 1 J (see page 386).

### [AI3 Highest Process] R , 3 K

AI3 highest process.

Identical to [AI1 Highest Process] R , 1 K (see page 386).

## [AI4 configuration] P F R 4 - Menu

### Access

[Complete settings] → [Pump functions] → [Pipe fill] → [AI4 configuration]

### About This Menu

This menu can be accessed if:

- [Activation Mode] P F Π is set to [Outlet pressure] P 5 2, and
- [OutletPres Assign] P 5 2 R is set to [AI4] R , 4.

### [AI4 Type] R , 4 4 ★

Configuration of analog input AI4.

This parameter can be accessed if VW3A3203 I/O extension module has been inserted.

Setting	Code / Value	Description
[Voltage]	I 0 4	0-10 Vdc
[Current]	0 R	0-20 mA
[Voltage +/-]	n I 0 4	-10/+10 Vdc <b>Factory setting</b>
[PTC Management]	P 4 C	1 to 6 PTC (in serial)
[KTY]	K 4 Y	1 KTY84
[PT1000]	I P 4 3	1 PT1000 connected with 2 wires
[PT100]	I P 4 2	1 PT100 connected with 2 wires
[3 PT1000]	3 P 4 3	3 PT1000 connected with 2 wires
[3 PT100]	3 P 4 2	3 PT100 connected with 2 wires
[PT1000 in 3 wires]	I P 4 3 3	1 PT1000 connected with 3 wires (AI4 & AI5 only)
[PT100 in 3 wires]	I P 4 2 3	1 PT100 connected with 3 wires (AI4 & AI5 only)
[3 PT1000 in 3 wires]	3 P 4 3 3	3 PT1000 connected with 3 wires (AI4 & AI5 only)
[3 PT100 in 3 wires]	3 P 4 2 3	3 PT100 connected with 3 wires (AI4 & AI5 only)

### [AI4 min value] 4 , L 4 ★

AI4 voltage scaling parameter of 0%.

Identical to [AI1 min value] 4 , L 1 (see page 385).

### [AI4 max value] 4 , H 4 ★

AI4 voltage scaling parameter of 100%.

Identical to [AI1 max value] 4 , H 1 (see page 385).

### [AI4 min. value] C r L 4 ★

AI4 current scaling parameter of 0%.

Identical to [AI1 min. value] C r L 1 (see page 385).

### [AI4 max. value] C r H 4 ★

AI4 current scaling parameter of 100%.

Identical to [AI1 max. value] C r H 1 (see page 385).

**[AI4 Lowest Process] R , 4 J**

AI4 lowest process.

Identical to **[AI1 Lowest Process] R , 1 J** (*see page 386*).

**[AI4 Highest Process] R , 4 K**

AI4 highest process.

Identical to **[AI1 Highest Process] R , 1 K** (*see page 386*).

## [AI5 configuration] P F R 5 - Menu

### Access

[Complete settings] → [Pump functions] → [Pipe fill] → [AI5 configuration]

### About This Menu

This menu can be accessed if:

- [Activation Mode] P F R is set to [Outlet pressure] P 5 2, and
- [OutletPres Assign] P 5 2 R is set to [AI5] R , 5.

### [AI5 Type] R , 5 E ★

Configuration of analog input AI5.

This parameter can be accessed if VW3A3203 I/O extension module has been inserted.

Identical to [AI4 Type] R , 4 E (see page 390).

### [AI5 min value] U , L 5 ★

AI5 voltage scaling parameter of 0%.

Identical to [AI1 min value] U , L 1 (see page 385).

### [AI5 max value] U , H 5 ★

AI5 voltage scaling parameter of 100%.

Identical to [AI1 max value] U , H 1 (see page 385).

### [AI5 min. value] C r L 5 ★

AI5 current scaling parameter of 0%.

Identical to [AI1 min. value] C r L 1 (see page 385).

### [AI5 max. value] C r H 5 ★

AI5 current scaling parameter of 100%.

Identical to [AI1 max. value] C r H 1 (see page 385).

### [AI5 Lowest Process] R , 5 J

AI5 lowest process.

Identical to [AI1 Lowest Process] R , 1 J (see page 386).

### [AI5 Highest Process] R , 5 K

AI5 highest process.

Identical to [AI1 Highest Process] R , 1 K (see page 386).



## [AIV1 configuration] P F V I - Menu

### Access

[Complete settings] → [Pump functions] → [Pipe fill] → [AIV1 configuration]

### About This Menu

This menu can be accessed if:

- [Activation Mode] P F Π is set to [Outlet pressure] P 5 2, and
- [OutletPres Assign] P 5 2 A is set to [AIV1] A , V I.

### [AIV1 Channel Assignment] A , C I

Channel assignment for virtual analog input AIV1.

Setting	Code / Value	Description
[Not Configured]	n o	Not assigned <b>Factory setting</b>
[Ref. Freq-Modbus]	Π d b	Reference frequency via Modbus
[Ref. Freq-CANopen]	C A n	Reference frequency via CANopen if a CANopen module has been inserted
[Ref. Freq-Com. Module]	n E t	Reference frequency via fieldbus module if a fieldbus module has been inserted
[Embedded Ethernet]	E t H	Embedded Ethernet

### [AIV1 Lowest Process] A U I J

AI virtual x: minimum process value.

Setting	Description
-32,767...32,767	Setting range <b>Factory setting: 0</b>

### [AIV1 Highest Process] A U I K

AI virtual x: maximum process value.

Setting	Description
-32,767...32,767	Setting range <b>Factory setting: 0</b>

**[Pipe fill] PF , - Menu****Access**

[Complete settings] → [Pump functions] → [Pipe fill]

**[Activation Source] PFE c ★**

Pipe fill activation source.

This parameter can be accessed if [Activation Mode] PF Π is not set to [No] n o .

Setting	Code / Value	Description
[Not Assigned]	n o	Not assigned <b>Factory setting</b>
[DI1]...[DI6]	L , I ... L , 6	Digital input DI1...DI6
[DI11]...[DI16]	L , I I ... L , 16	Digital input DI11...DI16 if VW3A3203 I/O extension module has been inserted
[CD00]...[CD10]	C d 0 0 ... C d 1 0	Virtual digital input CMD.0...CMD.10 in [I/O profile] , o configuration
[CD11]...[CD15]	C d 1 1 ... C d 1 5	Virtual digital input CMD.11...CMD.15 regardless of configuration
[C100]...[C110]	C 1 0 0 ... C 1 1 0	Virtual digital input CMD1.0...CMD1.10 with integrated Modbus Serial in [I/O profile] , o configuration
[C111]...[C115]	C 1 1 1 ... C 1 1 5	Virtual digital input CMD1.11...CMD1.15 with integrated Modbus Serial regardless of configuration
[C200]...[C210]	C 2 0 0 ... C 2 1 0	Virtual digital input CMD2.0...CMD2.10 with CANopen® fieldbus module in [I/O profile] , o configuration
[C211]...[C215]	C 2 1 1 ... C 2 1 5	Virtual digital input CMD2.11...CMD2.15 with CANopen® fieldbus module regardless of configuration
[C300]...[C310]	C 3 0 0 ... C 3 1 0	Virtual digital input CMD3.0...CMD3.10 with a fieldbus module in [I/O profile] , o configuration
[C311]...[C315]	C 3 1 1 ... C 3 1 5	Virtual digital input CMD3.11...CMD3.15 with a fieldbus module regardless of configuration
[C500]...[C510]	C 5 0 0 ... C 5 1 0	Virtual digital input CMD5.0...CMD5.10 with integrated Ethernet Modbus TCP in [I/O profile] , o configuration
[C511]...[C515]	C 5 1 1 ... C 5 1 5	Virtual digital input CMD5.11...CMD5.15 with integrated Ethernet Modbus TCP regardless of configuration
[DI1 (Low level)]...[DI6 (Low level)]	L I L ... L 6 L	Digital input DI1...DI6 used at low level
[DI11 (Low level)]...[DI16 (Low level)]	L I I L ... L 16 L	Digital input DI11...DI16 used at low level if VW3A3203 I/O extension module has been inserted

**[Pipe Fill on Wake Up] PFW u ★**

Pipe fill cycle on wake-up.

This parameter can be accessed if:

- [Access Level] L AC is set to [Expert] E P r .
- [Activation Mode] PF Π is not set to [No] n o .

Setting	Code / Value	Description
[No]	n o	No pipe fill cycle on wake-up
[Yes]	y e s	A pipe fill cycle operates on wake-up <b>Factory setting</b>

**[Pipe Fill Speed] P F H S ★**

Pipe fill speed.

This parameter can be accessed if

- **[Activation Mode] P F Π** is not set to **[No] n o**, and
- **[Activation Source] P F E c** is not set to **[Not Assigned] n o**.

Setting ( )	Description
0.0...500.0 Hz	Setting range <b>Factory setting:</b> 25.0 Hz

**[Pipe Fill Pressure] P F H P ★**

Pipe fill pressure level.

This parameter can be accessed if

- **[Activation Mode] P F Π** is not set to **[No] n o**, and
- **[Activation Source] P F E c** is not set to **[Not Assigned] n o**.

Setting ( )	Description
0...32,767	Setting range according to <b>[P sensor unit] S u P r</b> . <b>Factory setting:</b> 0

**[Pipe Fill Time] P F H t ★**

Pipe fill time.

This parameter can be accessed if

- **[Activation Mode] P F Π** is not set to **[No] n o**, and
- **[Activation Source] P F E c** is not set to **[Not Assigned] n o**.

Setting ( )	Description
0...32,767 s	Setting range <b>Factory setting:</b> 10 s

## Section 7.16

### [Pump functions] - [Friction loss compensation]

#### What Is in This Section?

This section contains the following topics:

Topic	Page
[Friction loss comp] <i>F L C</i> - Menu	397
[AI1 Installation Flow] <i>F , F 1</i> - Menu	398
[AI2 Installation Flow] <i>F , F 2</i> - Menu	400
[AI3 Installation Flow] <i>F , F 3</i> - Menu	401
[AI4 Installation Flow] <i>F , F 4</i> - Menu	402
[AI5 Installation Flow] <i>F , F 5</i> - Menu	404
[PI5 Installation Flow] <i>F , F B</i> - Menu	405
[PI6 Installation Flow] <i>F , F 9</i> - Menu	406
[AIV1 Installation flow] <i>F , u 1</i> - Menu	407
[Friction loss comp] <i>F L C</i> - Menu	408

## [Friction loss comp] *F L C* - Menu

### Access

[Complete settings] → [Pump functions] → [Friction loss comp]

### About This Menu

This function monitors the system flow and displays an estimation of the head losses of the application.

This function can compensate these head losses by modifying the pressure set point. It helps to maintain a constant pressure at usage point whatever the flow demand.

This monitoring function is at station level and not a pump level only.

This function requires a flow sensor to monitor the flow of the system.

The dynamic estimation of the losses is based on values measured by the application:

- The static losses [**Static Compensation**] *F L H D* measured at no flow between the pumping point and the usage point.
- The dynamic losses, based on an application working point (Flow [**Flow at Point 1**] *F L P 1* ; Head [**Static Compensation**] *F L H D*) measured at nominal flow of the system.

If the function is set to compensation mode, the pressure set point is modified according to the estimated pressure drop.

**NOTE:** At low flow working point, as dynamic head losses are lower than at the nominal working point, this function reduces the pressure set point and thus allows saving electrical power.

### [Mode Selection] *F L C P* ★

Mode selection.

Setting	Code / Value	Description
[Inactive]	<i>n o</i>	Inactive <b>Factory setting</b>
[Display]	<i>P o n</i>	Monitoring only: pressure drop is not used for compensation
[Compensation]	<i>C o P P</i>	Compensation: pressure drop is used to correct pressure set-point

### [Inst. Flow Assign.] *F 5 I A*

Installation flow sensor assignment.

This parameter can be accessed if [**Mode Selection**] *F L C P* is not set to [**No**] *n o*.

Setting	Code / Value	Description
[Not Configured]	<i>n o</i>	Not assigned <b>Factory setting</b>
[AI1]...[AI3]	<i>A , 1...A , 3</i>	Analog input AI1...AI3
[AI4]...[AI5]	<i>A , 4...A , 5</i>	Analog input AI4...AI5 if VW3A3203 I/O extension module has been inserted
[AI Virtual 1]	<i>A , V 1</i>	Virtual analogic input 1
[PulseInput Assignment On DI5]...[PulseInput Assignment On DI6]	<i>P , 5...P , 6</i>	Digital input DI5...DI6 used as pulse input
[Flow Estimation]	<i>S L P F</i>	Sensor less estimated flow

**[AI1 Installation Flow] F , F I - Menu****Access**

[Complete settings] → [Pump functions] → [Friction loss compensation] → [AI1 Installation Flow]

**About This Menu**

The following parameters can be accessed if [Mode Selection] F L C Π is not set to [Inactive] n o and [Inst. Flow Assign.] F S I R is set to [AI1] R , I .

**[AI1 Type] R , I E**

Configuration of analog input AI1.

Setting	Code / Value	Description
[Voltage]	I O u	0-10 Vdc <b>Factory setting</b>
[Current]	O R	0-20 mA

**[AI1 min value] u , L I ★**

AI1 voltage scaling parameter of 0%.

This parameter can be accessed if [AI1 Type] R , I E is not set to [Current] O R .

Setting	Description
0.0...10.0 V	Setting range <b>Factory setting:</b> 0.0 V

**[AI1 max value] u , H I ★**

AI1 voltage scaling parameter of 100%.

This parameter can be accessed if [AI1 Type] R , I E is not set to [Current] O R .

Setting	Description
0.0...10.0 V	Setting range <b>Factory setting:</b> 10.0 V

**[AI1 min. value] C r L I ★**

AI1 current scaling parameter of 0%.

This parameter can be accessed if [AI1 Type] R , I E is set to [Current] O R .

Setting	Description
0.0...20.0 mA	Setting range <b>Factory setting:</b> 0.0 mA

**[AI1 max. value] C r H I ★**

AI1 current scaling parameter of 100%.

This parameter can be accessed if [AI1 Type] R , I E is set to [Current] O R .

Setting	Description
0.0...20.0 mA	Setting range <b>Factory setting:</b> 20.0 mA

**[A11 Lowest Process]R , I J**

Minimum process value for selected input.

Setting	Description
-32,768...32,767	Setting range. Value in application customer unit. <b>Factory setting:</b> 0

**[A11 Highest Process]R , I K**

Maximum process value for selected input.

Setting	Description
-32,768...32,767	Setting range. Value in application customer unit. <b>Factory setting:</b> 0

## [AI2 Installation Flow] F , F 2 - Menu

### Access

[Complete settings] → [Pump functions] → [Friction loss compensation] → [AI2 Installation Flow]

### About This Menu

The following parameters can be accessed if [Mode Selection] F L C Π is not set to [Inactive] n o and [Inst. Flow Assign.] F 5 I R is set to [AI2] R , 2 .

### [AI2 Type] R , 2 E

Configuration of analog input AI2.

Setting	Code / Value	Description
[Voltage]	I D u	0-10 Vdc <b>Factory setting</b>
[Current]	o R	0-20 mA
[PTC Management]	P E C	1 to 6 PTC (in serial)
[KTY]	K E Y	1 KTY84
[PT1000]	I P E 3	1 PT1000 connected with 2 wires
[PT100]	I P E 2	1 PT100 connected with 2 wires
[Water Prob]	L E u E L	Water level
[3PT1000]	3 P E 3	3 PT1000 connected with 2 wires
[3PT100]	3 P E 2	3 PT100 connected with 2 wires

### [AI2 min value] u , L 2 ★

AI2 voltage scaling parameter of 0%.

This parameter can be accessed if [AI2 Type] R , 2 E is set to [Voltage] I D u .

Identical to [AI1 min value] u , L 1 (see page 398).

### [AI2 max value] u , H 2 ★

AI2 voltage scaling parameter of 100%.

This parameter can be accessed if [AI2 Type] R , 2 E is set to [Voltage] I D u .

Identical to [AI1 max value] u , H 1 (see page 398).

### [AI2 min. value] C r L 2 ★

AI2. current scaling parameter of 0%

This parameter can be accessed if [AI2 Type] R , 2 E is set to [Current] o R .

Identical to [AI1 min. value] C r L 1. (see page 398)

### [AI2 max. value] C r H 2 ★

AI2 current scaling parameter of 100%

This parameter can be accessed if [AI2 Type] R , 2 E is set to [Current] o R .

Identical to [AI1 max. value] C r H 1. (see page 398)

### [AI2 Lowest Process] R , 2 J

Minimum process value for selected input.

Identical to [AI1 Lowest Process] R , 1 J. (see page 399)

### [AI2 Highest Process] R , 2 K

Maximum process value for selected input.

Identical to [AI1 Highest Process] R , 1 K. (see page 399)



## [AI3 Installation Flow] F , F 3 - Menu

### Access

[Complete settings] → [Pump functions] → [Friction loss compensation] → [AI3 Installation Flow]

### About This Menu

The following parameters can be accessed if [Mode Selection] F L C Π is not set to [Inactive] n o and [Inst. Flow Assign.] F 5 I A is set to [AI3] A , 3 .

### [AI3 Type] A , 3 E

Configuration of analog input AI3.

Identical to [AI2 Type] A , 2 E (see page 400) with factory setting: [Current] o A .

### [AI3 min value] u , L 3 ★

AI3 voltage scaling parameter of 0%.

This parameter can be accessed if [AI3 Type] A , 3 E is set to [Current] I o u .

Identical to [AI1 min value] u , L 1 (see page 398).

### [AI3 max value] u , H 3 ★

AI3 current scaling parameter of 100%.

This parameter can be accessed if [AI3 Type] A , 3 E is set to [Current] I o u .

Identical to [AI1 max value] u , H 1 (see page 398).

### [AI3 min. value] C r L 3 ★

AI3 current scaling parameter of 0%.

This parameter can be accessed if [AI3 Type] A , 3 E is set to [Voltage] o A .

Identical to [AI1 min. value] C r L 1 . (see page 398)

### [AI3 max. value] C r H 3 ★

AI3 current scaling parameter of 0%.

This parameter can be accessed if [AI3 Type] A , 3 E is set to [Voltage] o A .

Identical to [AI1 max. value] C r H 1 . (see page 398)

### [AI3 Lowest Process] A , 3 J

Minimum process value for selected input.

Identical to [AI1 Lowest Process] A , 1 J . (see page 399)

### [AI3 Highest Process] A , 3 K

Maximum process value for selected input.

Identical to [AI1 Highest Process] A , 1 K . (see page 399)

**[AI4 Installation Flow] F , F 4 - Menu****Access**

[Complete settings] → [Pump functions] → [Friction loss compensation] → [AI4 Installation Flow]

**About This Menu**

Identical to [AI1 Installation Flow] F , F 1 - (see page 329).

The following parameters can be accessed if [Mode Selection] F L C 11 is not set to [Inactive] n 0 and [Inst. Flow Assign.] F 5 1A is set to [AI 4] A , 4.

**[AI4 Type] A , 4 E**

Configuration of analog input AI4.

This parameter can be accessed if VW3A3203 I/O extension module has been inserted.

Setting	Code / Value	Description
[Voltage]	I 0 0	0-10 Vdc
[Current]	0 A	0-20 mA
[Voltage +/-]	n I 0 0	-10/+10 Vdc <b>Factory setting</b>
[PTC Management]	P E C	1 to 6 PTC (in serial)
[KTY]	K E Y	1 KTY84
[PT1000]	I P E 3	1 PT1000 connected with 2 wires
[PT100]	I P E 2	1 PT100 connected with 2 wires
[3 PT1000]	3 P E 3	3 PT1000 connected with 2 wires
[3 PT100]	3 P E 2	3 PT100 connected with 2 wires
[PT1000 in 3 wires]	I P E 3 3	1 PT1000 connected with 3 wires (AI4 & AI5 only)
[PT100 in 3 wires]	I P E 2 3	1 PT100 connected with 3 wires (AI4 & AI5 only)
[3 PT1000 in 3 wires]	3 P E 3 3	3 PT1000 connected with 3 wires (AI4 & AI5 only)
[3 PT100 in 3 wires]	3 P E 2 3	3 PT100 connected with 3 wires (AI4 & AI5 only)

**[AI4 min value] 0 , L 4 ★**

AI4 voltage scaling parameter of 0%.

Identical to [AI1 min value] 0 , L 1 (see page 398).

**[AI4 max value] 0 , H 4 ★**

AI4 voltage scaling parameter of 0%.

Identical to [AI1 max value] 0 , H 1 (see page 398).

**[AI4 min. value] C r L 4 ★**

AI4 current scaling parameter of 0%.

Identical to [AI1 min. value] C r L 1 . (see page 398)

**[AI4 max. value] C r H 4 ★**

AI4 current scaling parameter of 0%.

Identical to [AI1 max. value] C r H 1 . (see page 398)

**[AI4 Lowest Process] R , 4 J**

Minimum process value for selected input.

Identical to **[AI1 Lowest Process] R , 1 J**. (*see page 399*)

**[AI4 Highest Process] R , 4 K**

Maximum process value for selected input.

Identical to **[AI1 Highest Process] R , 1 K**. (*see page 399*)

## [AI5 Installation Flow] F , F 5 - Menu

### Access

[Complete settings] → [Pump functions] → [Friction loss compensation] → [AI5 Installation Flow]

### About This Menu

The following parameters can be accessed if [Mode Selection] F L C 11 is not set to [Inactive] n 0 and [Inst. Flow Assign.] F 5 I 11 is set to [AI4 ] 11 , 4 .

### [AI5 Type] 11 , 5 L ★

Configuration of analog input AI5.

This parameter can be accessed if VW3A3203 I/O extension module has been inserted.

Identical to [AI4 Type] 11 , 4 L (see page 402).

### [AI5 min value] 11 , L 5 ★

AI5 voltage scaling parameter of 0%.

Identical to [AI1 min value] 11 , L 1 (see page 398).

### [AI5 max value] 11 , H 5 ★

AI5 voltage scaling parameter of 0%.

Identical to [AI1 max value] 11 , H 1 (see page 398).

### [AI5 min. value] C r L 5 ★

AI5 current scaling parameter of 0%.

Identical to [AI1 min. value] C r L 1 . (see page 398)

### [AI5 max. value] C r H 5 ★

AI5 current scaling parameter of 0%.

Identical to [AI1 max. value] C r H 1 . (see page 398)

### [AI5 Lowest Process] 11 , 5 J

Minimum process value for selected input.

Identical to [AI1 Lowest Process] 11 , I J . (see page 399)

### [AI5 Highest Process] 11 , 5 K

Maximum process value for selected input.

Identical to [AI1 Highest Process] 11 , I K . (see page 399)

## [PI5 Installation Flow] *F* , *F B* - Menu

### Access

[Complete settings] → [Pump functions] → [Friction loss compensation] → [PI5 Installation Flow]

### About This Menu

The following parameters can be accessed if [Mode Selection] *F L C P* is not set to [Inactive] *n o* and [Inst. Flow Assign.] *F S I A* is set to [DI5 PulseInput Assignment] *P* , *5*.

### [PulseInput DI5 Low Freq] *P* , *L 5*

Minimum pulse input.

Pulse input DI5: frequency for 0% of the equivalent analog signal.

Setting	Description
0.00...30,000.00 Hz	Setting range <b>Factory setting:</b> 0 Hz

### [PulseInput DI5 High Freq] *P* , *H 5*

Maximum pulse input.

Pulse input DI5: frequency for 100% of the equivalent analog signal.

Setting	Description
0.00...30.00 kHz	Setting range <b>Factory setting:</b> 30.00 kHz

### [DI5 Min Process] *P* , *5 J*

Minimum process value for selected input.

Setting	Description
-32,768...32,767	Setting range <b>Factory setting:</b> 0

### [DI5 Max Process] *P* , *5 K*

Maximum process value for selected input.

Setting	Description
-32,768...32,767	Setting range <b>Factory setting:</b> 0

**[PI6 Installation Flow] F , F 9 - Menu****Access**

[Complete settings] → [Pump functions] → [Friction loss compensation] → [PI6 Installation Flow]

**About This Menu**

The following parameters can be accessed if **[Mode Selection] F L C 11** is not set to **[Inactive] n 0** and **[Inst. Flow Assign.] F 5 I 8** is set to **[DI6 PulseInput Assignment] P , 5**.

**[PulseInput DI6 Low Freq] P , L 5**

Minimum pulse input.

Pulse input DI5: frequency for 0% of the equivalent analog signal.

Setting	Description
0.00...30,000.00 Hz	Setting range <b>Factory setting:</b> 0 Hz

**[PulseInput DI6 High Freq] P , H 5**

Maximum pulse input.

Pulse input DI5: frequency for 100% of the equivalent analog signal.

Setting	Description
0.00...30.00 kHz	Setting range <b>Factory setting:</b> 30.00 kHz

**[DI6 Min Process] P , 5 J**

Minimum process value for selected input.

Setting	Description
-32,768...32,767	Setting range <b>Factory setting:</b> 0

**[DI6 Max Process] P , 5 K**

Maximum process value for selected input.

Setting	Description
-32,768...32,767	Setting range <b>Factory setting:</b> 0

## [AIV1 Installation flow] *F I U I* - Menu

### Access

[Complete settings] → [Pump functions] → [Friction loss compensation] → [AIV1 Installation flow]

### About This Menu

The following parameters can be accessed if **[Mode Selection] *F L C P*** is not set to **[Inactive] *n o*** and **[Inst. Flow Assign.] *F S I A*** is set to **[AI Virtual 1] *A I U I***.

### [AIV1 Channel Assignment] *A I C I*

Channel assignment for virtual analog input AIV1.

Setting	Code / Value	Description
[Not Configured]	<i>n o</i>	Not assigned <b>Factory setting</b>
[Ref. Freq-Modbus]	<i>M d b</i>	Reference frequency via Modbus
[Ref. Freq-CANopen]	<i>C A n</i>	Reference frequency via CANopen if a CANopen module has been inserted
[Ref. Freq-Com. Module]	<i>n E t</i>	Reference frequency via fieldbus module if a fieldbus module has been inserted
[Embedded Ethernet]	<i>E t H</i>	Embedded Ethernet

### [AIV1 Lowest Process] *A U I J*

AI virtual x: minimum process value.

Setting	Description
-32,767...32,767	Setting range <b>Factory setting: 0</b>

### [AIV1 Highest Process] *A U I K*

AI virtual x: maximum process value.

Setting	Description
-32,767...32,767	Setting range <b>Factory setting: 0</b>

**[Friction loss comp] *FLC* - Menu****Access**

[Complete settings] → [Pump functions] → [Friction loss comp]

**About This Menu**

The following parameters can be accessed if **[Mode Selection] *FLC*** is not set to **[Inactive] *no*** and **[Inst. Flow Assign.] *FSIR*** is set to **[Not Configured] *no***.

**[Static Compensation] *FLHD* ★**

Static compensation.

Setting ( )	Description
0...32,767	Setting range Factory setting: 0

**[Flow at Point 1] *FL9I* ★**

Flow at point 1.

Setting ( )	Description
0...32,767	Setting range Factory setting: 0

**[Comp. at Point 1] *FLHI* ★**

Compensation at point 1.

Setting ( )	Description
0...32,767	Setting range Factory setting: 0

**[Alpha] *FLdR* ★**

Alpha.

This parameter can be accessed if **[Access Level] *LRC*** is set to **[Expert] *EP***.

Setting ( )	Description
0.0...2.0	Setting range Factory setting: 2.0

**[Delta Pressure] *FLPd* ★**

Friction loss delta pressure.

Setting ( )	Description
-32,768...32,767	Setting range Factory setting: _



## Section 7.17

### [Pump functions] - [Jockey pump]

#### [Jockey pump] $J K P$ - Menu

##### Access

[Complete settings] → [Pump functions] → [Jockey pump]

##### About This Menu

This menu can be accessed if:

- [Type of control]  $t o c t$  is set to [PRESSURE]  $P r E S S$ , and
- [PID feedback]  $P i F$  is assigned, and
- [Sleep Detect Mode]  $S L P M$  is not set to [No]  $n o$ .

This function allows managing a jockey pump.

The jockey pump can be:

- A direct on-line pump in parallel to the variable speed pump, controlled by a digital output, or
- The variable speed pump used at fixed speed.

The jockey pump works in on/off control between two pressure set points.

The jockey pump is used during sleep period to maintain the service pressure.

From an energy efficiency point of view, it is better to start and stop a fixed speed pump than running the variable speed pump continuously at low speed.

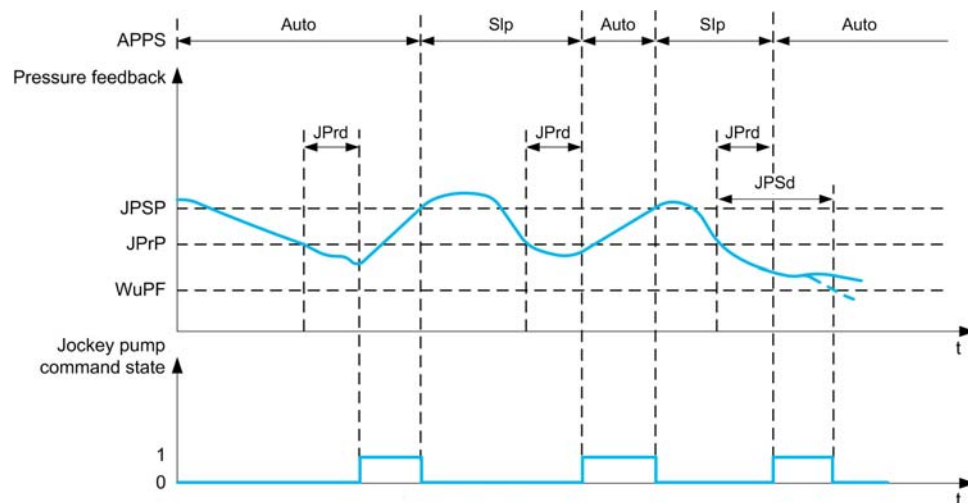

During sleep mode, the pressure feedback is still monitored:

- If the pressure feedback falls below the jockey start pressure [Minimum Pressure]  $J P r P$  during a time longer than [Delay to Start]  $J P r d$ , the jockey pump is started;
- If the pressure feedback is over jockey stop pressure [Maximum Pressure]  $J P S P$ , the jockey pump is stopped

When the jockey pump is started, the pressure feedback is still monitored:

- If the pressure feedback stays below the jockey start pressure [Maximum Pressure]  $J P S P$  for longer than the wake-up delay [Wake Up Delay]  $J P w d$ , it means that the request is greater than what jockey pump can supply alone. The system wakes up and exit from sleep mode.
- If the pressure feedback falls below the wake-up pressure [Wake UP Process level]  $W u P F$ , the system wakes up and exit from sleep mode.

**[Jockey Selection] JP**

Select the jockey pump.

Setting	Code / Value	Description
[No]	<i>no</i>	Not assigned <b>Factory setting</b>
[R2]...[R3]	<i>r 2...r 3</i>	Relay output R2...R3
[R4]...[R6]	<i>r 4...r 6</i>	Relay output R4...R6 if VW3A3204 relay output option module has been inserted
[Analog output DQ11]...[Analog output DQ12]	<i>do 11...do 12</i>	Analog / digital output DO11...DO12 if VW3A3203 I/O extension module has been inserted

**[Minimum Pressure] JP r P ★**

Pressure threshold to start the jockey pump.

This parameter can be accessed if **[Jockey Selection] JP** is not set to **[No] no**.

Setting ( )	Description
0...[Maximum Pressure] JP 5 P	Setting range <b>Factory setting:</b> 0

**[Delay to Start] JP r d ★**

Delay to start the jockey pump.

This parameter can be accessed if **[Jockey Selection] JP** is not set to **[No] no**.

Setting ( )	Description
0...3,600 s	Setting range <b>Factory setting:</b> 0 s

**[Maximum Pressure] JP 5 P ★**

Pressure threshold to stop the jockey pump.

This parameter can be accessed if **[Jockey Selection] JP** is not set to **[No] no**.

Setting ( )	Description
[Minimum Pressure] JP r P...32,767	Setting range <b>Factory setting:</b> 0

**[Wake Up Delay] JP W d ★**

Delay to wake up the system when pressure feedback stays low.

This parameter can be accessed if **[Jockey Selection] JP** is not set to **[No] no**.

Setting ( )	Description
[No] no...3,600 s	Setting range <b>Factory setting:</b> no

**[Reference Speed] JP r S ★**

Pump speed when **[VSP] V 5 P** is selected as jockey pump.

This parameter can be accessed if **[Jockey Selection] JP** is set to **[VSP] V 5 P**.

Setting ( )	Description
[Low Speed] L 5 P...[High Speed] H 5 P	Setting range <b>Factory setting:</b> [Maximum Pressure] JP 5 P

---

## Section 7.18

### [Pump functions] - [Priming pump ctrl]

---

#### What Is in This Section?

This section contains the following topics:

Topic	Page
[Priming pump ctrl] <i>PPC</i> - Menu	412
[AI1 configuration] <i>PPR1</i> - Menu	415
[AI2 configuration] <i>PPR2</i> - Menu	417
[AI3 configuration] <i>PPR3</i> - Menu	418
[AI4 configuration] <i>PPR4</i> - Menu	419
[AI5 configuration] <i>PPR5</i> - Menu	420
[AIV1 configuration] <i>Pfv1</i> - Menu	421
[Priming pump ctrl] <i>PPC</i> - Menu	422

## [Priming pump ctrl] P P C - Menu

### Access

[Complete settings] → [Pump functions] → [Priming pump ctrl]

### About This Menu

This function manages a priming pump.

The priming pump is placed at the inlet of the variable speed lead pump, controlled with a digital output.

The priming pump is used to maintain the inlet pressure to the lead pump.

This is done by running the priming pump before the main pump starts. Nevertheless, it is recommended to enable the dry-Run monitoring function.

The priming pumps keep pumping as long as the lead pump is active.

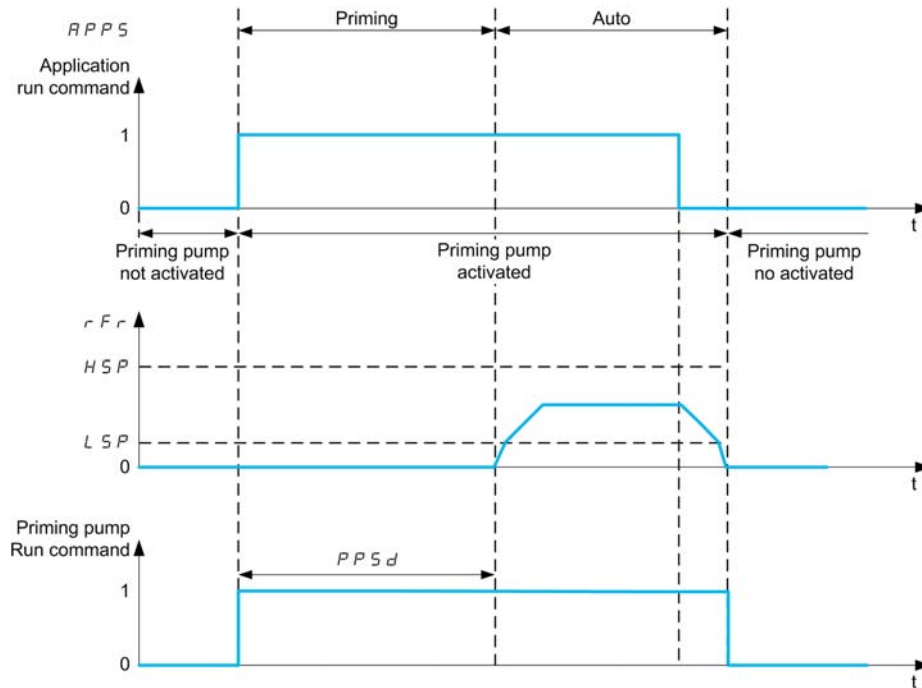

If the priming pump function is activated and the conditions to start the lead pump are present, the priming pump is started immediately while the lead pump will be started when one of the primed conditions is met :

- After the [Priming Time] P P S d delay
- When the digital input assigned with [Primed Switch Assign] P P W R is active for longer than [Primed Condition Delay] P P F d.
- When the analog input assigned with [InletPres Assign] P S I R is over [Primed Inlet Level] P P , L for longer than [Primed Condition Delay] P P F d.

If the priming pump is active, it is stopped when the lead pump is stopped, at the end of the deceleration phase.

When the system goes to the sleep mode, the priming pump is also deactivated.

When the system wakes up, the priming pump is immediately activated while the lead pump will be started when one of the primed conditions is met.

**NOTE:** If, for any reason, one of the pumps has to stop, the other pump has to be stopped too.

**[Priming Pump Assign] P P o R**

Select the priming pump.

Setting	Code / Value	Description
[No]	n o	Not assigned <b>Factory setting</b>
[R2]...[R3]	r 2...r 3	Relay output R2...R3
[R4]...[R6]	r 4...r 6	Relay output R4...R6 if VW3A3204 relay output option module has been inserted
[Analog output DQ11]...[Analog output DQ12]	d o 1 1...d o 1 2	Analog / digital output DO11...DO12 if VW3A3203 I/O extension module has been inserted

**[Primed Switch Assign] P P W R ★**

Primed condition: external switch assignment.

This parameter can be accessed if **[Priming Pump Assign] P P o R** is not set to **[No] n o**.

Setting	Code / Value	Description
[Not Assigned]	n o	Not assigned <b>Factory setting</b>
[DI1]...[DI6]	L , 1...L , 6	Digital input DI1...DI6
[DI11]...[DI16]	L , 1 1...L , 1 6	Digital input DI11...DI16 if VW3A3203 I/O extension module has been inserted
[CD00]...[CD10]	C d 0 0...C d 1 0	Virtual digital input CMD.0...CMD.10 in <b>[I/O profile] , o</b> configuration
[CD11]...[CD15]	C d 1 1...C d 1 5	Virtual digital input CMD.11...CMD.15 regardless of configuration
[C100]...[C110]	C 1 0 0...C 1 1 0	Virtual digital input CMD1.0...CMD1.10 with integrated Modbus Serial in <b>[I/O profile] , o</b> configuration
[C111]...[C115]	C 1 1 1...C 1 1 5	Virtual digital input CMD1.11...CMD1.15 with integrated Modbus Serial regardless of configuration
[C200]...[C210]	C 2 0 0...C 2 1 0	Virtual digital input CMD2.0...CMD2.10 with CANopen® fieldbus module in <b>[I/O profile] , o</b> configuration
[C211]...[C215]	C 2 1 1...C 2 1 5	Virtual digital input CMD2.11...CMD2.15 with CANopen® fieldbus module regardless of configuration
[C300]...[C310]	C 3 0 0...C 3 1 0	Virtual digital input CMD3.0...CMD3.10 with a fieldbus module in <b>[I/O profile] , o</b> configuration
[C311]...[C315]	C 3 1 1...C 3 1 5	Virtual digital input CMD3.11...CMD3.15 with a fieldbus module regardless of configuration
[C500]...[C510]	C 5 0 0...C 5 1 0	Virtual digital input CMD5.0...CMD5.10 with integrated Ethernet Modbus TCP in <b>[I/O profile] , o</b> configuration
[C511]...[C515]	C 5 1 1...C 5 1 5	Virtual digital input CMD5.11...CMD5.15 with integrated Ethernet Modbus TCP regardless of configuration
[DI1 (Low level)]...[DI6 (Low level)]	L , 1 L...L , 6 L	Digital input DI1...DI6 used at low level
[DI11 (Low level)]...[DI16 (Low level)]	L , 1 1 L...L , 1 6 L	Digital input DI11...DI16 used at low level if VW3A3203 I/O extension module has been inserted

**[Primed Inlet Level] P P , L ★**

Primed condition: inlet pressure detection level.

This parameter can be accessed if **[Priming Pump Assign] P P o R** is not set to **[No] n o**.

Setting	Code / Value	Description
[No]	0	Function disabled <b>Factory setting</b>
0.1...3276.0		Setting range according to the configuration done in the <b>[Define system units] 5 u C -</b> menu

**[InletPres Assign] P 5 I R** ★

Inlet pressure sensor assignment.

This parameter can be accessed if:

- **[Priming Pump Assign] P P o R** is not set to **[No] n o**.
- **[Primed Inlet Level] P P , L** is not set to **[No] n o**.

Setting	Code / Value	Description
<b>[Not Configured]</b>	<b>n o</b>	Not assigned <b>Factory setting</b>
<b>[AI1]...[AI3]</b>	<b>R , 1...R , 3</b>	Analog input AI1...AI3
<b>[AI4]...[AI5]</b>	<b>R , 4...R , 5</b>	Analog input AI4...AI5 if VW3A3203 I/O extension module has been inserted
<b>[AI Virtual 1]</b>	<b>R , V 1</b>	Virtual analogic input 1

## [AI1 configuration] P P R I - Menu

### Access

[Complete settings] → [Pump functions] → [Priming pump ctrl] → [AI1 configuration]

### About This Menu

This menu can be accessed if [InletPres Assign] P 5 I R is set to [AI1] R , I .

### [AI1 Type] R , I E

Configuration of analog input AI1.

Setting	Code / Value	Description
[Voltage]	I 0 u	0-10 Vdc <b>Factory setting</b>
[Current]	0 R	0-20 mA

### [AI1 min value] u , L I ★

AI1 voltage scaling parameter of 0%.

This parameter can be accessed if [AI1 Type] R , I E is set to [Voltage] I 0 u .

Setting	Description
0.0...10.0 Vdc	Setting range <b>Factory setting:</b> 0.0 Vdc

### [AI1 max value] u , H I ★

AI1 voltage scaling parameter of 100%.

This parameter can be accessed if [AI1 Type] R , I E is set to [Voltage] I 0 u .

Setting	Description
0.0...10.0 Vdc	Setting range <b>Factory setting:</b> 10.0 Vdc

### [AI1 min. value] C r L I ★

AI1 current scaling parameter of 0%.

This parameter can be accessed if [AI1 Type] R , I E is set to [Current] 0 R .

Setting	Description
0.0...20.0 mA	Setting range <b>Factory setting:</b> 0.0 mA

### [AI1 max. value] C r H I ★

AI1 current scaling parameter of 100%.

This parameter can be accessed if [AI1 Type] R , I E is set to [Current] 0 R .

Setting	Description
0.0...20.0 mA	Setting range <b>Factory setting:</b> 20.0 mA

**[A11 Lowest Process] R , I J**

A11 lowest process.

Setting	Description
-32,767...32,767	Setting range. Value in application customer unit. <b>Factory setting:</b> 0

**[A11 Highest Process] R , I K**

A11 highest process.

Setting	Description
-32,767...32,767	Setting range. Value in application customer unit. <b>Factory setting:</b> 0



## [AI2 configuration] P P R 2 - Menu

### Access

[Complete settings] → [Pump functions] → [Priming pump ctrl] → [AI2 configuration]

### About This Menu

This menu can be accessed if [InletPres Assign] P 5 I R is set to [AI2] R , 2 .

### [AI2 Type] R , 2 E

Configuration of analog input AI2.

Setting	Code / Value	Description
[Voltage]	I 0 U	0-10 Vdc <b>Factory setting</b>
[Current]	0 R	0-20 mA
[PTC Management]	P E C	1 to 6 PTC (in serial)
[KTY]	K E Y	1 KTY84
[PT1000]	I P E 3	1 PT1000 connected with 2 wires
[PT100]	I P E 2	1 PT100 connected with 2 wires
[Water Prob]	L E U E L	Water level
[3PT1000]	3 P E 3	3 PT1000 connected with 2 wires
[3PT100]	3 P E 2	3 PT100 connected with 2 wires

### [AI2 min value] U , L 2 ★

AI2 voltage scaling parameter of 0%.

This parameter can be accessed if [AI2 Type] R , 2 E is set to [Voltage] I 0 U .

Identical to [AI1 min value] U , L 1 (see page 385).

### [AI2 max value] U , H 2 ★

AI2 voltage scaling parameter of 100%.

This parameter can be accessed if [AI2 Type] R , 2 E is set to [Voltage] I 0 U .

Identical to [AI1 max value] U , H 1 (see page 385).

### [AI2 min. value] C r L 2 ★

AI2 current scaling parameter of 0%.

This parameter can be accessed if [AI2 Type] R , 2 E is set to [Current] 0 R .

Identical to [AI1 min. value] C r L 1 (see page 385).

### [AI2 max. value] C r H 2 ★

AI2 current scaling parameter of 100%.

This parameter can be accessed if [AI2 Type] R , 2 E is set to [Current] 0 R .

Identical to [AI1 max. value] C r H 1 (see page 385).

### [AI2 Lowest Process] R , 2 J

AI2 lowest process.

Identical to [AI1 Lowest Process] R , 1 J (see page 386).

### [AI2 Highest Process] R , 2 K

AI2 highest process.

Identical to [AI1 Highest Process] R , 1 K (see page 386).

## [AI3 configuration] P P R 3 - Menu

### Access

[Complete settings] → [Pump functions] → [Priming pump ctrl] → [AI3 configuration]

### About This Menu

This menu can be accessed if [InletPres Assign] P 5 I R is set to [AI3] R , 3 .

### [AI3 Type] R , 3 E

Configuration of analog input AI3.

Identical to [AI2 Type] R , 2 E with factory setting: [Current] 0 R (see page 387).

### [AI3 min value] 0 , L 3 ★

AI3 voltage scaling parameter of 0%.

This parameter can be accessed if [AI2 Type] R , 2 E is set to [Voltage] 1 0 0 .

Identical to [AI1 min value] 0 , L 1 (see page 385).

### [AI3 max value] 0 , H 3 ★

AI3 voltage scaling parameter of 100%.

This parameter can be accessed if [AI3 Type] R , 3 E is set to [Voltage] 1 0 0 .

Identical to [AI1 max value] 0 , H 1 (see page 385).

### [AI3 min. value] 0 , L 3 ★

AI3 current scaling parameter of 0%.

This parameter can be accessed if [AI3 Type] R , 3 E is set to [Current] 0 R .

Identical to [AI1 min. value] 0 , L 1 (see page 385).

### [AI3 max. value] 0 , H 3 ★

AI3 current scaling parameter of 100%.

This parameter can be accessed if [AI3 Type] R , 3 E is set to [Current] 0 R .

Identical to [AI1 max. value] 0 , H 1 (see page 385).

### [AI3 Lowest Process] R , 3 J

AI3 lowest process.

Identical to [AI1 Lowest Process] R , 1 J (see page 386).

### [AI3 Highest Process] R , 3 K

AI3 highest process.

Identical to [AI1 Highest Process] R , 1 K (see page 386).

## [AI4 configuration] P P R 4 - Menu

### Access

[Complete settings] → [Pump functions] → [Priming pump ctrl] → [AI4 configuration]

### About This Menu

This menu can be accessed if [InletPres Assign] P 5 I R is set to [AI4] R , 4.

### [AI4 Type] R , 4 L ★

Configuration of analog input AI4.

This parameter can be accessed if VW3A3203 I/O extension module has been inserted.

Setting	Code / Value	Description
[Voltage]	I 0 u	0-10 Vdc
[Current]	0 R	0-20 mA
[Voltage +/-]	n I 0 u	-10/+10 Vdc <b>Factory setting</b>
[PTC Management]	P t C	1 to 6 PTC (in serial)
[KTY]	K t Y	1 KTY84
[PT1000]	I P t 3	1 PT1000 connected with 2 wires
[PT100]	I P t 2	1 PT100 connected with 2 wires
[3 PT1000]	3 P t 3	3 PT1000 connected with 2 wires
[3 PT100]	3 P t 2	3 PT100 connected with 2 wires
[PT1000 in 3 wires]	I P t 3 3	1 PT1000 connected with 3 wires (AI4 & AI5 only)
[PT100 in 3 wires]	I P t 2 3	1 PT100 connected with 3 wires (AI4 & AI5 only)
[3 PT1000 in 3 wires]	3 P t 3 3	3 PT1000 connected with 3 wires (AI4 & AI5 only)
[3 PT100 in 3 wires]	3 P t 2 3	3 PT100 connected with 3 wires (AI4 & AI5 only)

### [AI4 min value] u , L 4 ★

AI4 voltage scaling parameter of 0%.

Identical to [AI1 min value] u , L 1 (see page 385).

### [AI4 max value] u , H 4 ★

AI4 voltage scaling parameter of 100%.

Identical to [AI1 max value] u , H 1 (see page 385).

### [AI4 min. value] C r L 4 ★

AI4 current scaling parameter of 0%.

Identical to [AI1 min. value] C r L 1 (see page 385).

### [AI4 max. value] C r H 4 ★

AI4 current scaling parameter of 100%.

Identical to [AI1 max. value] C r H 1 (see page 385).

### [AI4 Lowest Process] R , 4 J

AI4 lowest process.

Identical to [AI1 Lowest Process] R , I J (see page 386).

### [AI4 Highest Process] R , 4 K

AI4 highest process.

Identical to [AI1 Highest Process] R , I K (see page 386).

## [AI5 configuration] P P R 5 - Menu

### Access

[Complete settings] → [Pump functions] → [Priming pump ctrl] → [AI5 configuration]

### About This Menu

This menu can be accessed if [InletPres Assign] P 5 I R is set to [AI5] R , 5 .

### [AI5 Type] R , 5 L ★

Configuration of analog input AI5.

This parameter can be accessed if VW3A3203 I/O extension module has been inserted.

Identical to [AI4 Type] R , 4 L (see page 390).

### [AI5 min value] L , L 5 ★

AI5 voltage scaling parameter of 0%.

Identical to [AI1 min value] L , L 1 (see page 385).

### [AI5 max value] L , H 5 ★

AI5 voltage scaling parameter of 100%.

Identical to [AI1 max value] L , H 1 (see page 385).

### [AI5 min. value] L r L 5 ★

AI5 current scaling parameter of 0%.

Identical to [AI1 min. value] L r L 1 (see page 385).

### [AI5 max. value] L r H 5 ★

AI5 current scaling parameter of 100%.

Identical to [AI1 max. value] L r H 1 (see page 385).

### [AI5 Lowest Process] R , 5 J

AI5 lowest process.

Identical to [AI1 Lowest Process] R , 1 J (see page 386).

### [AI5 Highest Process] R , 5 K

AI5 highest process.

Identical to [AI1 Highest Process] R , 1 K (see page 386).

## [AIV1 configuration] P F V I - Menu

### Access

[Complete settings] → [Pump functions] → [Priming pump ctrl] → [AIV1 configuration]

### About This Menu

This menu can be accessed if [InletPres Assign] P 5 I A is set to [AIV1] A , V I .

### [AIV1 Channel Assignment] A , C I

Channel assignment for virtual analog input AIV1.

Setting	Code / Value	Description
[Not Configured]	n o	Not assigned <b>Factory setting</b>
[Ref. Freq-Modbus]	Π d b	Reference frequency via Modbus
[Ref. Freq-CANopen]	ϸ A n	Reference frequency via CANopen if a CANopen module has been inserted
[Ref. Freq-Com. Module]	n E t	Reference frequency via fieldbus module if a fieldbus module has been inserted
[Embedded Ethernet]	E t H	Embedded Ethernet

### [AIV1 Lowest Process] A , I J

AI virtual x: minimum process value.

Setting	Description
-32,767...32,767	Setting range <b>Factory setting: 0</b>

### [AIV1 Highest Process] A , I K

AI virtual x: maximum process value.

Setting	Description
-32,767...32,767	Setting range <b>Factory setting: 0</b>

**[Priming pump ctrl] P P C - Menu****Access**

[Complete settings] → [Pump functions] → [Priming pump ctrl]

**[Primed Condition Delay] P P F d ★**

Primed condition delay.

This parameter can be accessed if:

- [Priming Pump Assign] P P a R is not set to [No] n a.
- [Primed Switch Assign] P P w R is not set to [Not Assigned] n a.
- [Primed Inlet Level] P P i L is not set to [No] D.

Setting ( )	Description
0...60 s	Setting range Factory setting: 0 s

**[Priming Time] P P S d ★**

Delay before starting the lead pump.

This parameter can be accessed if [Priming Pump Assign] P P a R is not set to [No] n a.

Setting ( )	Description
0...3,600 s	Setting range Factory setting: 30 s

## Section 7.19

### [Pump functions] - [Flow limitation]

#### What Is in This Section?

This section contains the following topics:

Topic	Page
[Flow limitation] <i>F L 11</i> - Menu	424
[AI1 sensor config.] <i>L F 1</i> - Menu	426
[AI2 sensor config.] <i>L F 2</i> - Menu	428
[AI3 sensor config.] <i>L F 3</i> - Menu	429
[AI4 sensor config.] <i>L F 4</i> - Menu	430
[AI5 sensor config.] <i>L F 5</i> - Menu	432
[DI5 Pulse Sensor Config.] <i>L F B</i> - Menu	433
[DI6 Pulse Sensor Config.] <i>L F 9</i> - Menu	434
[AIV1 Pulse sensor config.] <i>L F 11</i> - Menu	435
[Flow limitation] <i>F L 11</i> - Menu	436

**[Flow limitation] *F L Π* - Menu**

**Access**

[Complete settings] → [Pump functions] → [Flow limitation]

**About This Menu**

This function allows you to limit the flow of the system to a configured value (according to local requirements, regulation, or availability of water).

This monitoring function is at station level and not a pump level only.

This function requires a flow sensor to monitor the flow of the system.

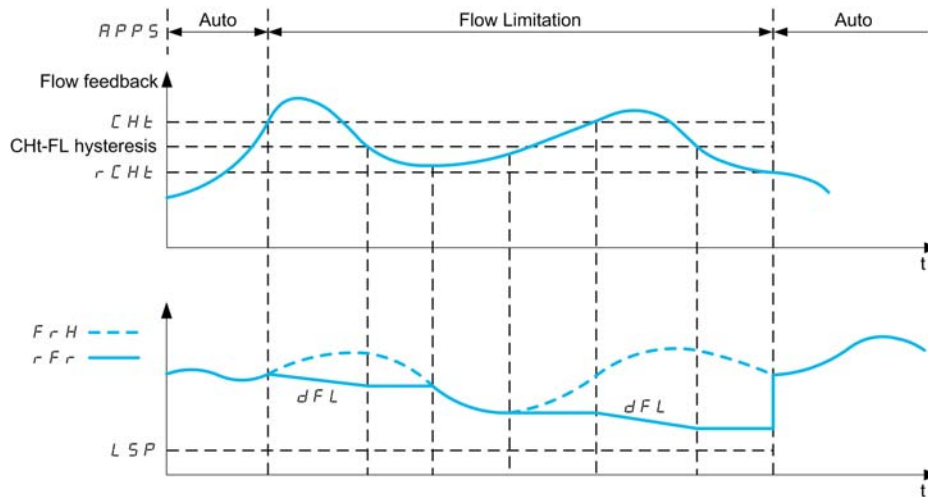

When the flow feedback is higher than the high flow **[Flow Lim Thd Active] CHt**, the pump reduces the speed set point according to the deceleration ramp **[Flow. Limit Dec.] dFL**.

When the flow feedback is lower than the high flow **[Flow Lim Thd Active] CHt** reduced by a fixed hysteresis value, the pump speed is maintained or reduced if the reference frequency decrease.

When the flow feedback is lower than the low flow **[FlowLim Thd Disable] rCHt**, the flow limitation stops and the pump speed follows the system reference frequency.

**NOTE:** This function does not decrease the motor speed under **[Low Speed] LSP** value.

**[Flow limitation Mode] *F L Π***

Flow limitation mode.

Setting	Code / Value	Description
[No]	no	No Factory setting
[YES]	YES	Yes



**[Inst. Flow Assign.] F 5 I R ★**

Installation flow sensor assignment.

This parameter can be accessed if **[Flow limitation Mode] F L M** is not set to **[No] n o**.

Setting	Code / Value	Description
<b>[Not Configured]</b>	<i>n o</i>	Not assigned <b>Factory setting</b>
<b>[AI1]...[AI3]</b>	<i>R , 1...R , 3</i>	Analog input AI1...AI3
<b>[AI4]...[AI5]</b>	<i>R , 4...R , 5</i>	Analog input AI4...AI5 if VW3A3203 I/O extension module has been inserted
<b>[AI Virtual 1]</b>	<i>R , V 1</i>	Virtual analogic input 1
<b>[PulseInput Assignment On DI5]...[PulseInput Assignment On DI6]</b>	<i>P , 5...P , 6</i>	Digital input DI5...DI6 used as pulse input
<b>[Flow Estimation]</b>	<i>S L P F</i>	Sensor less estimated flow

**[AI1 sensor config.] L F I - Menu****Access**

[Complete settings] → [Pump functions] → [Flow limitation] → [AI1 sensor config.]

**About This Menu**

The following parameters can be accessed if [Mode Selection] F L C Π is not set to [Inactive] n o and [Inst. Flow Assign.] F S I R is set to [AI1] R , I .

**[AI1 Type] R , I E**

Configuration of analog input AI1.

Setting	Code / Value	Description
[Voltage]	I O u	0-10 Vdc <b>Factory setting</b>
[Current]	O R	0-20 mA

**[AI1 min value] u , L I ★**

AI1 voltage scaling parameter of 0%.

This parameter can be accessed if [AI1 Type] R , I E is set to [Voltage] I O u .

Setting	Description
0.0...10.0 V	Setting range <b>Factory setting:</b> 0.0 V

**[AI1 max value] u , H I ★**

AI1 voltage scaling parameter of 100%.

This parameter can be accessed if [AI1 Type] R , I E is set to [Voltage] I O u .

Setting	Description
0.0...10.0 V	Setting range <b>Factory setting:</b> 10.0 V

**[AI1 min. value] C r L I ★**

AI1 current scaling parameter of 0%.

This parameter can be accessed if [AI1 Type] R , I E is set to [Current] O R .

Setting	Description
0.0...20.0 mA	Setting range <b>Factory setting:</b> 0.0 mA

**[AI1 max. value] C r H I ★**

AI1 current scaling parameter of 100%.

This parameter can be accessed if [AI1 Type] R , I E is set to [Current] O R .

Setting	Description
0.0...20.0 mA	Setting range <b>Factory setting:</b> 20.0 mA

**[A11 Lowest Process]R , I J**

Minimum process value for selected input.

Setting	Description
-32,768...32,767	Setting range. Value in application customer unit. <b>Factory setting:</b> 0

**[A11 Highest Process]R , I K**

Maximum process value for selected input.

Setting	Description
-32,768...32,767	Setting range. Value in application customer unit. <b>Factory setting:</b> 0

## [AI2 sensor config.] *L F 2* - Menu

### Access

[Complete settings] → [Pump functions] → [Flow limitation] → [AI2 sensor config.]

### About This Menu

The following parameters can be accessed if [Mode Selection] *F L C 11* is not set to [Inactive] *n 0* and [Inst. Flow Assign.] *F 5 I A* is set to [AI2] *A 1, 2*.

### [AI2 Type] *A 1, 2 E*

Configuration of analog input AI2.

Setting	Code / Value	Description
[Voltage]	<i>I 0 u</i>	0-10 Vdc Factory setting
[Current]	<i>0 A</i>	0-20 mA
[PTC Management]	<i>P E C</i>	1 to 6 PTC (in serial)
[KTY]	<i>K E Y</i>	1 KTY84
[PT1000]	<i>I P E 3</i>	1 PT1000 connected with 2 wires
[PT100]	<i>I P E 2</i>	1 PT100 connected with 2 wires
[Water Prob]	<i>L E u E L</i>	Water level
[3PT1000]	<i>3 P E 3</i>	3 PT1000 connected with 2 wires
[3PT100]	<i>3 P E 2</i>	3 PT100 connected with 2 wires

### [AI2 min value] *u 1, L 2* ★

AI2 voltage scaling parameter of 0%.

This parameter can be accessed if [AI2 Type] *A 1, 2 E* is set to [Voltage] *I 0 u*.

Identical to [AI1 min value] *u 1, L 1* (see page 426).

### [AI2 max value] *u 1, H 2* ★

AI2 voltage scaling parameter of 100%.

This parameter can be accessed if [AI2 Type] *A 1, 2 E* is set to [Voltage] *I 0 u*.

Identical to [AI1 max value] *u 1, H 1* (see page 426).

### [AI2 min. value] *C r L 2* ★

AI2 current scaling parameter of 0%.

This parameter can be accessed if [AI2 Type] *A 1, 2 E* is set to [Current] *0 A 1*

Identical to [AI1 min. value] *C r L 2* (see page 426).

### [AI2 max. value] *C r H 2* ★

AI2 current scaling parameter of 100%.

This parameter can be accessed if [AI2 Type] *A 1, 2 E* is set to [Current] *0 A*.

Identical to [AI1 max. value] *C r H 1* (see page 426).

### [AI2 Lowest Process] *A 1, 2 J*

Minimum process value for selected input.

Identical to [AI1 Lowest Process] *A 1, 1 J* (see page 427).

### [AI2 Highest Process] *A 1, 2 K*

Maximum process value for selected input.

Identical to [AI1 Highest Process] *A 1, 1 K* (see page 427).

## [AI3 sensor config.] L F 3 - Menu

### Access

[Complete settings] → [Pump functions] → [Flow limitation] → [AI3 sensor config.]

### About This Menu

The following parameters can be accessed if **[Mode Selection]** F L C Π is not set to **[Inactive]** n o and **[Inst. Flow Assign.]** F 5 I A is set to **[AI3]** A , 3 .

### [AI3 Type] A , 3 E

Configuration of analog input AI3.

Identical to **[AI2 Type]** A , 2 E (see page 428) with factory setting: **[Current]** o A .

### [AI3 min value] u , L 3 ★

AI3 voltage scaling parameter of 0%.

This parameter can be accessed if **[AI3 Type]** A , 3 E is set to **[Voltage]** I o u .

Identical to **[AI1 min value]** u , L 1 (see page 426).

### [AI3 max value] u , H 3 ★

AI3 voltage scaling parameter of 100%.

This parameter can be accessed if **[AI3 Type]** A , 3 E is set to **[Voltage]** I o u .

Identical to **[AI1 max value]** u , H 1 (see page 426).

### [AI3 min. value] C r L 3 ★

AI3 current scaling parameter of 0%.

This parameter can be accessed if **[AI3 Type]** A , 3 E is set to **[Current]** o A .

Identical to **[AI1 min. value]** C r L 1 (see page 426).

### [AI3 max. value] C r H 3 ★

AI3 current scaling parameter of 100%.

This parameter can be accessed if **[AI3 Type]** A , 3 E is set to **[Current]** o A .

Identical to **[AI1 max. value]** C r H 1 (see page 426).

### [AI3 Lowest Process] A , 3 J

Minimum process value for selected input.

Identical to **[AI1 Lowest Process]** A , 1 J (see page 427).

### [AI3 Highest Process] A , 3 K

Maximum process value for selected input.

Identical to **[AI1 Highest Process]** A , 1 K (see page 427).

**[AI4 sensor config.] L F 4 - Menu**

**Access**

[Complete settings] → [Pump functions] → [Flow limitation] → [AI4 sensor config.]

**About This Menu**

The following parameters can be accessed if [Mode Selection] F L C 11 is not set to [Inactive] n 0 and [Inst. Flow Assign.] F 5 1 A is set to [AI 4] A , 4.

**[AI4 Type] A , 4 1 ★**

Configuration of analog input AI4.

This parameter can be accessed if VW3A3203 relay output option module has been inserted.

Setting	Code / Value	Description
[Voltage]	1 0 u	0-10 Vdc
[Current]	0 A	0-20 mA
[Voltage +/-]	n 1 0 u	-10/+10 Vdc <b>Factory setting</b>
[PTC Management]	P 1 C	1 to 6 PTC (in serial)
[KTY]	K 1 Y	1 KTY84
[PT1000]	1 P 1 3	1 PT1000 connected with 2 wires
[PT100]	1 P 1 2	1 PT100 connected with 2 wires
[3 PT1000]	3 P 1 3	3 PT1000 connected with 2 wires
[3 PT100]	3 P 1 2	3 PT100 connected with 2 wires
[PT1000 in 3 wires]	1 P 1 3 3	1 PT1000 connected with 3 wires (AI4 & AI5 only)
[PT100 in 3 wires]	1 P 1 2 3	1 PT100 connected with 3 wires (AI4 & AI5 only)
[3 PT1000 in 3 wires]	3 P 1 3 3	3 PT1000 connected with 3 wires (AI4 & AI5 only)
[3 PT100 in 3 wires]	3 P 1 2 3	3 PT100 connected with 3 wires (AI4 & AI5 only)

**[AI4 min value] u , L 4 ★**

AI4 voltage scaling parameter of 0%.

Identical to [AI1 min value] u , L 1 (see page 426).

**[AI4 max value] u , H 4 ★**

AI4 voltage scaling parameter of 100%.

Identical to [AI1 max value] u , H 1 (see page 426).

**[AI4 min. value] C r L 4 ★**

AI4 current scaling parameter of 0%.

Identical to [AI1 min. value] C r L 1 (see page 426).

**[AI4 max. value] C r H 4 ★**

AI4 current scaling parameter of 100%.

Identical to [AI1 max. value] C r H 1 (see page 426).

**[AI4 Lowest Process] *R* , *4 J***

Minimum process value for selected input.

Identical to **[AI1 Lowest Process] *R* , *1 J*** (*see page 427*).

**[AI4 Highest Process] *R* , *4 K***

Maximum process value for selected input.

Identical to **[AI1 Highest Process] *R* , *1 K*** (*see page 427*).

## [AI5 sensor config.] L F 5 - Menu

### Access

[Complete settings] → [Pump functions] → [Flow limitation] → [AI5 sensor config.]

### About This Menu

The following parameters can be accessed if [Mode Selection] F L C 11 is not set to [Inactive] n 0 and [Inst. Flow Assign.] F 5 1 A is set to [AI5] A , 5 .

### [AI5 Type] A , 5 E ★

Configuration of analog input AI5.

This parameter can be accessed if VW3A3203 relay output option module has been inserted.

Identical to [AI4 Type] A , 4 E (see page 430).

### [AI5 min value] A , L 5 ★

AI5 voltage scaling parameter of 0%.

Identical to [AI1 min value] A , L 1 (see page 426).

### [AI5 max value] A , H 5 ★

AI5 voltage scaling parameter of 100%.

Identical to [AI1 max value] A , H 1 (see page 426).

### [AI5 min. value] C r L 5 ★

AI5 current scaling parameter of 0%.

Identical to [AI1 min. value] C r L 1 (see page 426).

### [AI5 max. value] C r H 5 ★

AI5 current scaling parameter of 100%.

Identical to [AI1 max. value] C r H 1 (see page 426).

### [AI5 Lowest Process] A , 5 J

Minimum process value for selected input.

Identical to [AI1 Lowest Process] A , 1 J (see page 427).

### [AI5 Highest Process] A , 5 K

Maximum process value for selected input.

Identical to [AI1 Highest Process] A , 1 K (see page 427).



## [DI5 Pulse Sensor Config.] *L F B* - Menu

### Access

[Complete settings] → [Pump functions] → [Flow limitation] → [DI5 Pulse Sensor Config.]

### About This Menu

The following parameters can be accessed if [Flow limitation Mode] *F L M* is not set to [No] *n o* and [Inst. Flow Assign.] *F S I A* is set to [DI5 PulseInput Assignment] *P , 5*.

### [PulseInput DI5 Low Freq] *P , L 5*

Pulse input DI5 low frequency.

Setting	Description
0.00...30,000.00 Hz	Setting range Factory setting: 0.00 Hz

### [PulseInput DI5 High Freq] *P , H 5*

Pulse input DI5 high frequency.

Setting	Description
0.00...30.00 kHz	Setting range Factory setting: 30.00 kHz

### [DI5 Min Process] *P , 5 J*

Minimum process value for selected input.

Setting	Description
-32,768...32,767	Setting range Factory setting: 0

### [DI5 Max Process] *P , 5 K*

Maximum process value for selected input.

Setting	Description
-32,768...32,767	Setting range Factory setting: 0

## [DI6 Pulse Sensor Config.] L F 9 - Menu

### Access

[Complete settings] → [Pump functions] → [Flow limitation] → [DI6 Pulse Sensor Config.]

### About This Menu

Identical to [DI5 Pulse Sensor Config.] L F 8 - Menu (*see page 337*).

The following parameters can be accessed if [Flow limitation Mode] F L 11 is not set to [No] n 0 and [Inst. Flow Assign.] F 5 18 is set to [DI6 PulseInput Assignment] P , 6 .

### [PulseInput DI6 Low Freq] P , L 6

Pulse input DI6 low frequency.

### [PulseInput DI6 High Freq] P , H 6

Pulse input DI6 high frequency.

### [DI6 Min Process] P , 6 J

Minimum process value for selected input.

### [DI6 Max Process] P , 6 K

Maximum process value for selected input.

## [AIV1 Pulse sensor config.] *L F U I* - Menu

### Access

[Complete settings] → [Pump functions] → [Flow limitation] → [AIV1 Pulse sensor config.]

### About This Menu

The following parameters can be accessed if [Flow limitation Mode] *F L M* is not set to [No] *n o* and [Inst. Flow Assign.] *F S I A* is set to [AI Virtual 1] *A I V 1*.

### [AIV1 Channel Assignment] *A , C I*

Channel assignment for virtual analog input AIV1.

Setting	Code / Value	Description
[Not Configured]	<i>n o</i>	Not assigned <b>Factory setting</b>
[Ref. Freq-Modbus]	<i>M o d b</i>	Reference frequency via Modbus
[Ref. Freq-CANopen]	<i>C A N</i>	Reference frequency via CANopen if a CANopen module has been inserted
[Ref. Freq-Com. Module]	<i>n E E</i>	Reference frequency via fieldbus module if a fieldbus module has been inserted
[Embedded Ethernet]	<i>E E H</i>	Embedded Ethernet

### [AIV1 Lowest Process] *A U I J*

AI virtual x: minimum process value.

Setting	Description
-32,767...32,767	Setting range <b>Factory setting:</b> 0

### [AIV1 Highest Process] *A U I K*

AI virtual x: maximum process value.

Setting	Description
-32,767...32,767	Setting range <b>Factory setting:</b> 0

**[Flow limitation] F L Π - Menu****Access**

[Complete settings] → [Pump functions] → [Flow limitation]

**[Flow Lim Thd Active] C H E ★**

Flow limitation function threshold activation.

Setting ( )	Description
Value in application customer unit	Setting range <b>Factory setting:</b> 0.0

**[Flow.Lim.Thres.Inact.] r C H E ★**

Flow limitation function threshold deactivation.

Setting ( )	Description
Value in application customer unit	Setting range according to the configuration done in the <b>[Define system units] 5 v C - menu.</b> <b>Factory setting:</b> 0.0

**[Flow. Limit Dec.] d F L ★**

Flow limitation function deceleration time (between F r 5 and 0).

Setting ( )	Description
0.01...99.99 s <sup>(1)</sup>	Setting range <b>Factory setting:</b> 5.0 s
(1) Range 0.01 to 99.99 s or 0.1 to 999.9 s or 1.0 to 6,000.0 according to <b>[Ramp increment] i n r</b>	

## Section 7.20

### [Pump monitoring] - [Pumpcycle monitoring]

#### [Pumpcycle monitoring] $\llcorner$ $5P$ - Menu

##### Access

[Complete settings]  $\rightarrow$  [Pump monitoring]  $\rightarrow$  [Pumpcycle monitoring]

##### About This Menu

The purpose of this function is to monitor the number of start sequences during a configured time window in order to prevent from an unwanted aging of the system and to detect any abnormal operation.

An internal counter counts the number of pump start sequences. Each time the pump is started, the counter is incremented. It is decreased by one every time window corresponding to one start.

If the counter reaches the maximum number allowed [**PumpCycle MaxStarts**]  $PCPn$ , a warning [**Pump Cycle warning**]  $PCPw$  is triggered.

If a start command occurs while the detected warning is active, an error [**PumpCycle Start Error**]  $PCPF$  is triggered. The application follows the [**PumpCycleError Resp**]  $PCPb$  defined behavior.

Restarting the pump is allowed as soon as the counter decreases under the maximum number of starts allowed, if the detected error has been cleared.

The function is based on the sliding time window in which the pump start commands are counted.

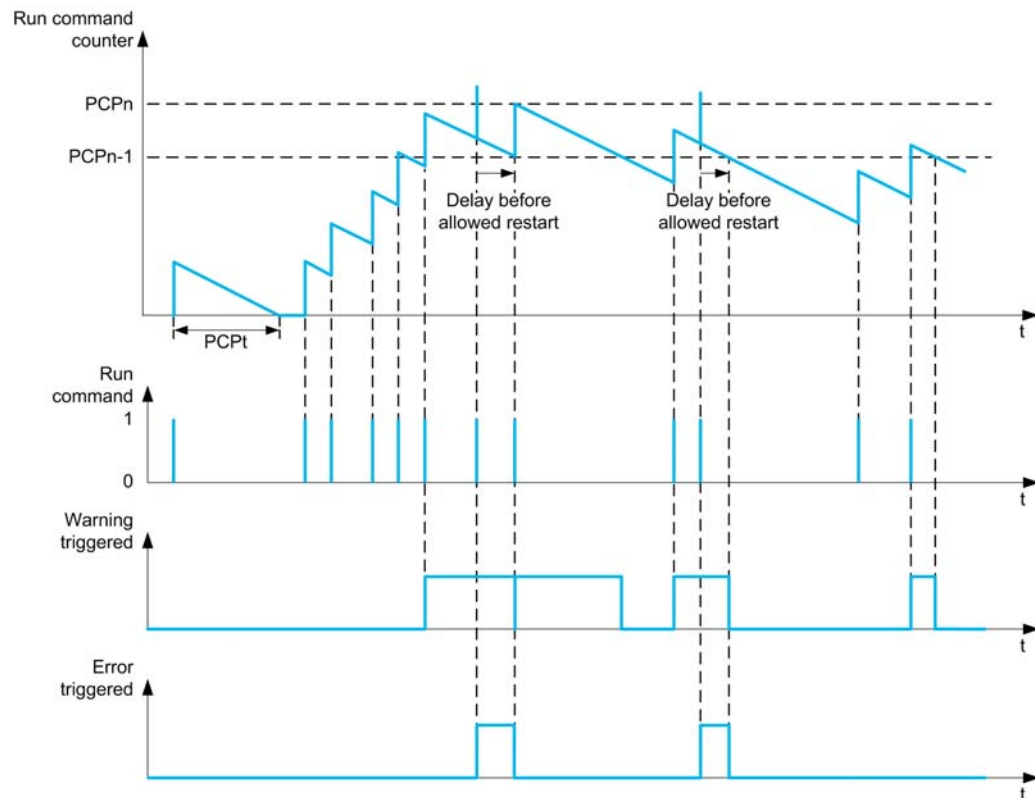

If [**PumpCycle Monitoring**]  $PCPn$  is set to [**Mode 1**]  $nor$ , the function is activated without power Off time management.

If [**PumpCycle Monitoring**]  $PCPn$  is set to [**Mode 2**]  $r \ell c$ , the function is activated with power Off time management. This requires a time clock source such as the Graphic Display Terminal plugged at power On of the drive, or a Time server configured over Ethernet.

**NOTE:** Anti-Jam sequence is counted as one start whatever the effective number of start commands in the sequence.

**[PumpCycle Monitoring] P C P Π**

Pumpcycle monitoring mode.

Setting	Code / Value	Description
[Inactive]	n o	Cyclic monitoring disabled <b>Factory setting</b>
[Standard]	n o r Π	Cyclic monitoring without power off time management
[With Memo]	r t t	Cyclic monitoring with power off time management

**[PumpCycle MaxStarts] P C P n ★**

Maximum number of events to trip.

This parameter can be accessed if [PumpCycle Monitoring] P C P Π is not set to [No] n o.

Setting ( )	Description
1...99	Setting range <b>Factory setting:</b> 6

**[PumpCycle Timeframe] P C P t ★**

Window time.

This parameter can be accessed if P C P Π is not set to [Inactive] n o.

Setting ( )	Description
0...3,600 min	Setting range <b>Factory setting:</b> 60 min

**[PumpCycleError Resp] P C P b ★**

Pumpcycle monitoring response to a detected error.

This parameter can be accessed if P C P Π is not set to [Inactive] n o.

Setting	Code / Value	Description
[Ignore]	n o	Detected error ignored
[Freewheel Stop]	y e s	Freewheel stop
[Per STT]	s t t	Stop according to [Type of stop] s t t parameter but without an error triggered after stop
[Fallback Speed]	L F F	Change to fallback speed, maintained as long as the detected error persists and the run command has not been removed <sup>(1)</sup>
[Ramp stop]	r Π P	Stop on ramp <b>Factory setting</b>

**1** Because, in this case, the detected error does not trigger a stop, it is recommended to assign a relay or logic output to its indication.

## Section 7.21

### [Pump monitoring] - [Anti jam]

#### [Anti-jam monit] J A N - Menu

##### Access

[Complete settings] → [Pump monitoring] → [Anti-jam monit]

##### About This Menu

In waste water applications, clogging substances reduce the efficiency of the system and may decrease the pump service life.

It may also help to clear a blocked impeller, pipe, or valve at downstream location.

The anti-Jam function allows, manually and/or automatically, to execute forward and reverse pump rotation cycles.

The frequency reference, acceleration and deceleration, in forward and in reverse direction can be adjusted by dedicated parameters. It allows you to set up the function in accordance with the application specifications. Refer to the pump datasheet while setting up the function.

**NOTE:** The anti-Jam configuration overrides other configurations such as [PID acceleration time] *A C C P* or [Start Accel Ramp] *A C C S*.

### NOTICE

#### DAMAGE TO THE PUMP

This function uses forward and reverse operations. Verify that the pump and the installation are compatible with reverse operation before setting up this function.

**Failure to follow these instructions can result in equipment damage.**

#### Anti-Jam Cycle

The anti-Jam function can be triggered:

- By an external trigger that can be assigned to a digital input (or word bit in IO profile).
- Automatically:
  - An automatic trigger can occur at each start command, or
  - Automatic triggers can occur within a predefined duration, or
  - Automatic triggers can occur depending on the motor torque threshold monitoring.

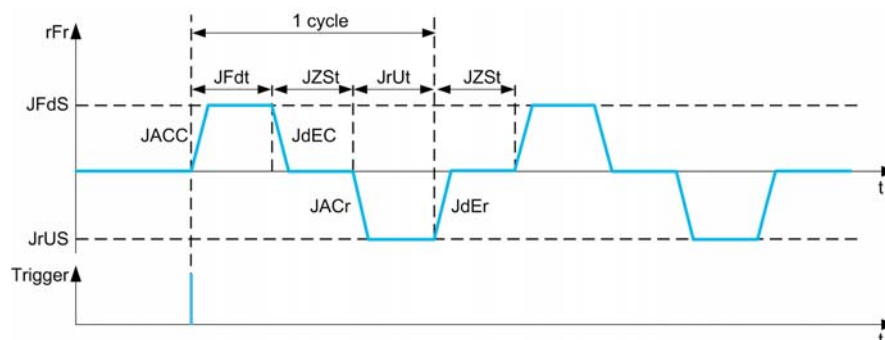

An Anti-Jam cycle is composed of:

- 1 forward action according to **[Anti-Jam Fwd Acc]** *J A C C*, **[Anti-Jam Fwd Time]** *J F d t*, **[Anti-Jam Fwd Speed]** *J F d S*, **[Anti-Jam Fwd Dec]** *J d E C*,
- 1 stop action during **[Anti-Jam Stop Time]** *J Z S t*,
- 1 reverse action according to **[Anti-Jam Rv Acc]** *J A C r*, **[Anti-Jam Rv Time]** *J r d t*, **[Anti-Jam Rv Speed]** *J r V S*, **[Anti-Jam Rv Dec]** *J d E r*,
- 1 stop action during **[Anti-Jam Stop Time]** *J Z S t*,

An Anti-Jam sequence corresponds to a number of consecutive anti-Jam cycles: **[Anti-Jam Cycle Nb]** *J n b C*

**NOTE:** In case of an external trigger, if the command is removed before the end of the anti-Jam sequence, the anti-Jam sequence continues up to the end. In addition to the trigger, a run command is necessary during the whole anti-Jam sequence.

**Anti-Jam Counting**

The anti-Jam function monitors the number of sequences during a configured time window **[Anti-Jam Interval]** *J A n t*. It helps to detect untimely aging of the system and abnormal operation. For example, it occurs on an automatic trigger on a motor torque threshold.

An internal counter counts the number of sequences. Each time the sequence is started, the counter is incremented. It is decremented for each time window corresponding to one start.

If the counter reaches the maximum number allowed, **[Anti-Jam Max Seq]** *J A n n*, a warning **[Anti-Jam Warning]** *J A n A* and an error **[Anti Jam Error]** *J A n F* are triggered. The application follows the **[Anti-Jam Error Resp]** *J A n b* behavior defined.

**[Anti-Jam Ext Trig]** *J E t C*

Switch input selection.

Setting	Code / Value	Description
<b>[Not Assigned]</b>	<i>n a</i>	Not assigned <b>Factory setting</b>
<b>[DI1]...[DI6]</b>	<i>L , l ... L , l B</i>	Digital input DI1...DI6
<b>[DI11]...[DI16]</b>	<i>L , l l ... L , l B</i>	Digital input DI11...DI16 if VW3A3203 I/O extension module has been inserted
<b>[CD00]...[CD10]</b>	<i>C d 0 0 ... C d 1 0</i>	Virtual digital input CMD.0...CMD.10 in <b>[I/O profile]</b> <i>l a</i> configuration
<b>[CD11]...[CD15]</b>	<i>C d 1 1 ... C d 1 5</i>	Virtual digital input CMD.11...CMD.15 regardless of configuration
<b>[C100]...[C110]</b>	<i>C 1 0 0 ... C 1 1 0</i>	Virtual digital input CMD1.0...CMD1.10 with integrated Modbus Serial in <b>[I/O profile]</b> <i>l a</i> configuration
<b>[C111]...[C115]</b>	<i>C 1 1 1 ... C 1 1 5</i>	Virtual digital input CMD1.11...CMD1.15 with integrated Modbus Serial regardless of configuration
<b>[C200]...[C210]</b>	<i>C 2 0 0 ... C 2 1 0</i>	Virtual digital input CMD2.0...CMD2.10 with CANopen® fieldbus module in <b>[I/O profile]</b> <i>l a</i> configuration
<b>[C211]...[C215]</b>	<i>C 2 1 1 ... C 2 1 5</i>	Virtual digital input CMD2.11...CMD2.15 with CANopen® fieldbus module regardless of configuration
<b>[C300]...[C310]</b>	<i>C 3 0 0 ... C 3 1 0</i>	Virtual digital input CMD3.0...CMD3.10 with a fieldbus module in <b>[I/O profile]</b> <i>l a</i> configuration
<b>[C311]...[C315]</b>	<i>C 3 1 1 ... C 3 1 5</i>	Virtual digital input CMD3.11...CMD3.15 with a fieldbus module regardless of configuration
<b>[C500]...[C510]</b>	<i>C 5 0 0 ... C 5 1 0</i>	Virtual digital input CMD5.0...CMD5.10 with integrated Ethernet Modbus TCP in <b>[I/O profile]</b> <i>l a</i> configuration
<b>[C511]...[C515]</b>	<i>C 5 1 1 ... C 5 1 5</i>	Virtual digital input CMD5.11...CMD5.15 with integrated Ethernet Modbus TCP regardless of configuration
<b>[DI1 (Low level)]...[DI6 (Low level)]</b>	<i>L l L ... L l B L</i>	Digital input DI1...DI6 used at low level
<b>[DI11 (Low level)]...[DI16 (Low level)]</b>	<i>L l l L ... L l B L</i>	Digital input DI11...DI16 used at low level if VW3A3203 I/O extension module has been inserted



**[Anti-Jam Auto Trig] J A E C**

Anti-Jam trigger mode.

Setting	Code / Value	Description
[No]	n o	Inactive
[Start]	S t r t	An automatic trigger occurs at each start command
[Time]	t , n e	Automatic triggers occur within a predefined duration
[Torque]	t r 9	Automatic triggers can occur depending on the motor torque threshold monitoring.

**[Anti-Jam Trigger Time] J E C t ★**

Inactive time before triggering an Anti-Jam when the pump has not been running.

This parameter can be accessed if [Anti-Jam Auto Trig] J A E C is set to [Time] t , n e.

Setting ( )	Description
0...9,999 h	Setting range Factory setting: 24 h

**[Anti-jam Torque] J E C L ★**

Level of torque to trigger.

This parameter can be accessed if [Anti-Jam Auto Trig] J A E C is set to [Torque] t r 9.

Setting ( )	Description
10...150%	Setting range Factory setting: 110%

**[Anti-Jam Start Delay] J E C d ★**

Delay to trigger when an overtorque is detected.

This parameter can be accessed if [Anti-Jam Auto Trig] J A E C is set to [Torque] t r 9.

Setting ( )	Description
0...3,600 s	Setting range Factory setting: 10 s

**[Anti-Jam Fwd Acc] J A C C ★**

Anti-Jam acceleration in forward.

This parameter can be accessed if:

- [Anti-Jam Ext Trig] J E E C is not set to [No] n o, or
- [Anti-Jam Auto Trig] J A E C is not set to [No] n o.

Setting ( )	Description
By default, with i n r = 0.1: 0.00...300.00 s	Setting range Factory setting: 3 s
If i n r = 0.01: 0.00...30.00 s	Setting range
If i n r = 1: 0.00...3000.00 s	Setting range

**[Anti-Jam Fwd Dec] JdEc** ★

Anti-Jam deceleration in forward.

This parameter can be accessed if:

- **[Anti-Jam Ext Trig] JEtc** is not set to **[No] na**, or
- **[Anti-Jam Auto Trig] JAetc** is not set to **[No] na**.

Setting ( )	Description
By default, with $inr = 0.1$ : 0.00...300.00 s	Setting range <b>Factory setting:</b> 3 s
If $inr = 0.01$ : 0.00...30.00 s	Setting range
If $inr = 1$ : 0.00...3000.00 s	Setting range

**[Anti-Jam Rv Acc] JRe** ★

Anti-Jam acceleration in reverse.

This parameter can be accessed if:

- **[Anti-Jam Ext Trig] JEtc** is not set to **[No] na**, or
- **[Anti-Jam Auto Trig] JAetc** is not set to **[No] na**.

Setting ( )	Description
By default, with $inr = 0.1$ : 0.00...300.00 s	Setting range <b>Factory setting:</b> 3 s
If $inr = 0.01$ : 0.00...30.00 s	Setting range
If $inr = 1$ : 0.00...3000.00 s	Setting range

**[Anti-Jam Rv Dec] JdEr** ★

Anti-Jam deceleration in reverse.

This parameter can be accessed if:

- **[Anti-Jam Ext Trig] JEtc** is not set to **[No] na**, or
- **[Anti-Jam Auto Trig] JAetc** is not set to **[No] na**.

Setting ( )	Description
By default, with $inr = 0.1$ : 0.00...300.00 s	Setting range <b>Factory setting:</b> 3 s
If $inr = 0.01$ : 0.00...30.00 s	Setting range
If $inr = 1$ : 0.00...3000.00 s	Setting range

**[Anti-Jam Fwd Speed] JFdS** ★

Anti-Jam speed in forward.

This parameter can be accessed if:

- **[Anti-Jam Ext Trig] JEtc** is not set to **[No] na**, or
- **[Anti-Jam Auto Trig] JAetc** is not set to **[No] na**.

Setting ( )	Description
0.0...500.0 Hz	Setting range <b>Factory setting:</b> 0.0 Hz

**[Anti-Jam Rv Speed] J R U 5 ★**

Anti-Jam speed in reverse.

This parameter can be accessed if:

- **[Anti-Jam Ext Trig] J E E C** is not set to **[No] n o**, or
- **[Anti-Jam Auto Trig] J A E C** is not set to **[No] n o**.

Setting ( )	Description
0.0...500.0 Hz	Setting range <b>Factory setting:</b> 0.0 Hz

**[Anti-Jam Fwd Time] J F d E ★**

Anti-Jam time in forward.

This parameter can be accessed if:

- **[Anti-Jam Ext Trig] J E E C** is not set to **[No] n o**, or
- **[Anti-Jam Auto Trig] J A E C** is not set to **[No] n o**.

Setting ( )	Description
0...300 s	Setting range <b>Factory setting:</b> 1 s

**[Anti-Jam Rv Time] J R U E ★**

Anti-Jam time in reverse.

This parameter can be accessed if:

- **[Anti-Jam Ext Trig] J E E C** is not set to **[No] n o**, or
- **[Anti-Jam Auto Trig] J A E C** is not set to **[No] n o**.

Setting ( )	Description
0...300 s	Setting range <b>Factory setting:</b> 1 s

**[Anti-Jam Stop Time] J Z 5 E ★**

Anti-Jam time between forward and reverse.

This parameter can be accessed if:

- **[Anti-Jam Ext Trig] J E E C** is not set to **[No] n o**, or
- **[Anti-Jam Auto Trig] J A E C** is not set to **[No] n o**.

Setting ( )	Description
0...300 s	Setting range <b>Factory setting:</b> 0 s

**[Anti-Jam Cycle Nb] J n b C ★**

Anti-Jam cycle number.

This parameter can be accessed if:

- **[Anti-Jam Ext Trig] J E E C** is not set to **[No] n o**, or
- **[Anti-Jam Auto Trig] J A E C** is not set to **[No] n o**.

Setting ( )	Description
1...100	Setting range <b>Factory setting:</b> 10

**[Anti-Jam Max Seq] J A Π n ★**

Maximum consecutive anti-Jam sequences allowed.

This parameter can be accessed if:

- **[Anti-Jam Ext Trig] J E E C** is not set to **[No] n o**, or
- **[Anti-Jam Auto Trig] J A E C** is not set to **[No] n o**.

Setting ( )	Description
1...99	Setting range <b>Factory setting: 2</b>

**[Anti-Jam Interval] J A Π E ★**

Anti-Jam minimum time between two non-consecutive sequences.

This parameter can be accessed if:

- **[Anti-Jam Ext Trig] J E E C** is not set to **[No] n o**, or
- **[Anti-Jam Auto Trig] J A E C** is not set to **[No] n o**.

Setting ( )	Description
0...3,600 s	Setting range <b>Factory setting: 60 s</b>

**[Anti-Jam Error Resp] J A Π b ★**

Anti-Jam monitoring function response to a detected error.

This parameter can be accessed if:

- **[Anti-Jam Ext Trig] J E E C** is not set to **[No] n o**, or
- **[Anti-Jam Auto Trig] J A E C** is not set to **[No] n o**.

Setting	Code / Value	Description
<b>[Ignore]</b>	n o	Detected error ignored
<b>[Freewheel Stop]</b>	Y E S	Freewheel stop <b>Factory setting</b>
<b>[Per STT]</b>	S E E	Stop according to <b>[Type of stop] S E E</b> parameter but without an error triggered after stop
<b>[Fallback Speed]</b>	L F F	Change to fallback speed, maintained as long as the detected error persists and the run command has not been removed <sup>(1)</sup>
<b>[Ramp stop]</b>	r P P	Stop on ramp
<b>1</b> Because, in this case, the detected error does not trigger a stop, it is recommended to assign a relay or logic output to its indication.		

## Section 7.22

### [Pump monitoring] - [Dry run]

#### [Dry run Monit] *d r M* - Menu

##### Access

[Complete settings] → [Pump monitoring] → [Dry run Monit]

##### Dry-Run Condition

A dry-run condition occurs when the pump impeller is not totally submerged. Working in dry running during a long time can cause premature wear of the pump impeller.

Dry run occurs when there is excessive air in the suction pipe:

- Because the pump is not primed, or
- Due to excessive air leak in the suction line.

This significantly may reduce the bearings and seal service life due to high temperature raise and poor lubrication.

##### About This Menu

This function prevents the pump from operating in dry condition.

The dry-run function monitors the flow using:

- a flow switch, or
- a set of 2 points (speed; power) for a flow estimation.

When using a flow switch, the dry-run condition occurs when the switch is at a high level.

**NOTE:** It is recommended to use a flow switch that is open in case of a low flow and to use a digital input active at low level (DixL). This allows you to stop the pump in case of a broken wire of the flow switch.

During the function setup, it is necessary to perform measurements at no-flow but with water in the system.

When using the flow estimation, the dry-run condition occurs if the estimated flow is lower than the no-flow power curve by [Dry Run Factor] *d r F*.

The no-flow power curve is defined by a set of 2 points:

- Minimum speed [Low Speed] *n F L S*; Power at minimum speed [Low Power] *n F L P*
- Maximum speed [High Speed] *n F H S*; Power at maximum speed [High Power] *n F H P*

This no-flow power curve is also used by the pump low flow monitoring function.

**NOTE:** The no-flow power curve characterization shall be done after setting the motor control type.

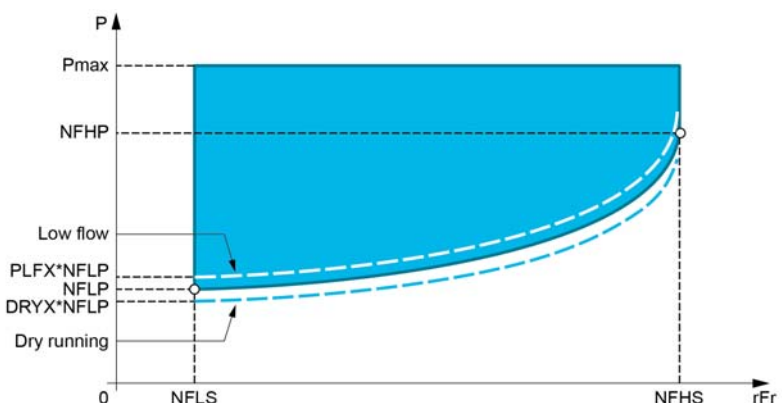

In case of dry-run conditions, this function will:

- Trigger a warning [Drive Running Warning] *d r W* if the dry-run condition is present.
- Trigger an error [Dry Run Error] *d r E* if the dry-run condition is present for a time longer than [DryRun Error Delay] *d r d*. After the error has been triggered, even if the detected error has been cleared, it is not possible to restart the pump before the end of the [DryRun Restart Delay] *d r r*.

**NOTE:** The detected error is not saved in case of a drive power OFF.

**[DryRun Mode] *drYN***

Dry-run mode.

Setting	Code / Value	Description
[No]	<i>no</i>	Not activated <b>Factory setting</b>
[Switch]	<i>SWt</i>	Using sensor switch
[Power]	<i>PWr</i>	Using the sensorless estimation

**[Switch Select] *drYW*★**

Dry-run switches select.

This parameter can be accessed if **[DryRun Mode] *drYN*** is set to **[Switch] *SWt***.

Setting	Code / Value	Description
[No]	<i>no</i>	Not assigned <b>Factory setting</b>
[DI1]...[DI6]	<i>L, I...L, B</i>	Digital input DI1...DI6
[DI11]...[DI16]	<i>L, I I...L, I B</i>	Digital input DI11...DI16, if VW3A3203 I/O extension module has been inserted
[DI1 (Low level)]...[DI6 (Low level)]	<i>L, I L...L, B L</i>	Digital input DI1...DI6 used at low level
[DI11 (Low level)]...[DI16 (Low level)]	<i>L, I I L...L, I B L</i>	Digital input DI11...DI16 used at low level if VW3A3203 I/O extension module has been inserted

**[Power Estim Value] *oPrW*★**

Motor mechanical power estimation

This parameter can be accessed if **[DryRun Mode] *drYN*** is set to **[Power] *PWr***.

Setting	Description
-327.67...327.67 kW	Setting range <b>Factory setting:</b> _

**[Low Power] *nFLP*★**

No-flow low power.

This parameter can be accessed if **[DryRun Mode] *drYN*** is set to **[Power] *PWr***.

Setting ( )	Description
0.00...327.67 kW	Setting range <b>Factory setting:</b> 0.00 kW

**[Low Speed] *nFLS*★**

No-flow low speed.

This parameter can be accessed if **[DryRun Mode] *drYN*** is set to **[Power] *PWr***.

Setting ( )	Description
0.0...500.0 Hz	Setting range <b>Factory setting:</b> 0.0 Hz

**[High Power] n F H P ★**

No-flow high power.

This parameter can be accessed if **[DryRun Mode] dr Y N** is set to **[Power] P W r**.

Setting ( )	Description
0.00...327.67 kW	Setting range <b>Factory setting:</b> 0.00 kW

**[High Speed] n F H S ★**

No-flow high speed.

This parameter can be accessed if **[DryRun Mode] dr Y N** is set to **[Power] P W r**.

Setting ( )	Description
0.0...500.0 Hz	Setting range <b>Factory setting:</b> 0.0 Hz

**[Dry Run Factor] dr Y X ★**

Dry-run factor.

This parameter can be accessed if **[DryRun Mode] dr Y N** is set to **[Power] P W r**.

Setting ( )	Description
0...100%	Setting range <b>Factory setting:</b> 70%

**[DryRun Error Delay] dr Y d ★**

Dry run detected error delay.

This parameter can be accessed if **[DryRun Mode] dr Y N** is not set to **[No] n o**.

Setting ( )	Description
0...3,600 s	Setting range <b>Factory setting:</b> 5 s

**[DryRun Restart Delay] dr Y r ★**

Dry run detected error restart.

This parameter can be accessed if **[DryRun Mode] dr Y N** is not set to **[No] n o**.

Setting ( )	Description
10...3,600 s	Setting range <b>Factory setting:</b> 60 s

## Section 7.23

### [Pump monitoring] - [Pump low flow Monit]

#### What Is in This Section?

This section contains the following topics:

Topic	Page
[Pump low flow Monit] <i>P L F</i> - Menu	449
[AI1 Sensor config.] <i>n P F 1</i> - Menu	451
[AI2 Sensor config.] <i>n P F 2</i> - Menu	453
[AI3 Sensor config.] <i>n P F 3</i> - Menu	455
[AI4 Sensor config.] <i>n P F 4</i> - Menu	456
[AI5 Sensor config.] <i>n P F 5</i> - Menu	458
[DI5 Pulse Sensor Config] <i>n P F 8</i> - Menu	459
[DI6 Pulse Sensor Config] <i>n P F 9</i> - Menu	460
[AIV1 Sensor config.] <i>n P V 1</i> - Menu	461
[Pump low flow Monit] <i>P L F</i> - Menu	462



## [Pump low flow Monit] P L F - Menu

### Access

[Complete settings] → [Pump monitoring] → [Pump low flow Monit]

### About This Menu

The main consequence of running in low flow pump area is an increase of pump temperature as the pump is cooled by the liquid flow.

In addition, the low flow area is not a good working area from energy efficiency point of view.

No flow or low flow could be caused by:

- The verify valve at the discharge is closed.
- Issue on the pipe at the discharge (blocked pipes, ...).

This function helps to prevent the pump from being damaged by working at no or low flow.

The monitoring can be carried out with different methods using or not sensors and whether the system is mono or multi-pump.

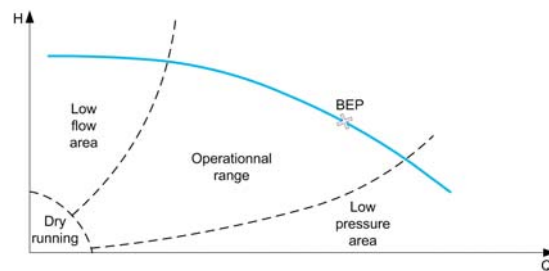

This function helps to detect probable no or low flow situation with different methods:

- Using a flow switch that indicates directly low flow condition: this method can be used only in mono-pump system or if the flow switch is connected on protected pump.
  - NOTE:** It is recommended to use a flow switch that is open in case of a low flow and to use a digital input active at low level (DIXL). This allows you to stop the pump in case of a broken wire of the flow switch.
- Using a flow sensor and comparing the actual flow value to a given threshold:
  - This method can be used only in mono-pump system or if the flow sensor is connected on protected pump.
  - All data related to the selected input shall be configured according to the sensor (Type, minimum, and maximum process value, scaling, ...).
- Using a flow sensor and comparing the actual flow value to "Low flow system curve" QN characteristic:
  - This method can be used only in mono-pump system or if the flow sensor is connected on protected pump.
  - All data related to the selected input shall be configured according to the sensor (Type, minimum, and maximum process value, scaling, ...).
- Using Power/Speed estimation and comparing pump working point to "No Flow" Power characteristic:
  - Entering two [Speed; Power] points is required, first point in No Flow area (at Low speed point LSP), second point in high-speed area (At high-speed point HSP).
  - This method is not recommended in case of flat PQ curve.

Low flow monitoring is activated only after **[PumpLF ActivDelay] P L F A** after the pump has been started in order to disable the monitoring function during start operation.

Once a low flow condition is detected, a warning **[Low Flow Warning] L F W** is raised. Warning is automatically cleared when drive is stopped.

If the condition continues for longer than the configured **[PumpLF Error Delay] P L F d** delay, a detected error is raised and the drive reacts according to the configured **[PumpLF Error Resp] P L F b** error response. The monitoring is active even during the deceleration phase. It is recommended to set a greater delay than the complete deceleration sequence.

After error has been detected, it is maintained during **[PumpLF Restart Delay] P L F r** even if the warning has been reset.

**NOTE:** the drive restarts without delay if it is powered-off and on (restart delay is not saved). During the setup of the function, it is necessary to perform measurements at no flow but with water in the system.

**[PumpLF Monitoring] P L F Π**

Pump low flow monitoring mode.

Setting	Code / Value	Description
[Not Configured]	<i>n o</i>	Not configured <b>Factory setting</b>
[Switch]	<i>5 W</i>	Using flow switch
[Flow]	<i>9</i>	Low flow is detected using fixed flow threshold
[Flow vs Speed]	<i>9 n</i>	Low flow is detected using flow vs speed
[No Flow power]	<i>n F</i>	Low flow is detected using no flow power characteristic

**[PumpLF DI Assign] P L F W ★**

Pump low flow no flow switch selection.

This parameter can be accessed if **[PumpLF Monitoring] P L F Π** is set to **[Switch] 5 W**.

Setting	Code / Value	Description
[Not Assigned]	<i>n o</i>	Not assigned <b>Factory setting</b>
[DI1]...[DI6]	<i>L , 1...L , 6</i>	Digital input DI1...DI6
[DI11]...[DI16]	<i>L , 11...L , 16</i>	Digital input DI11...DI16 if VW3A3203 I/O extension module has been inserted

**[Pump Flow Assign.] F S 2 A ★**

Pump flow sensor assignment.

This parameter can be accessed if **[PumpLF Monitoring] P L F Π** is set to **[Flow] 9** or to **[Flow vs Speed] 9 n**.

Setting	Code / Value	Description
[Not Configured]	<i>n o</i>	Not assigned <b>Factory setting</b>
[AI1]...[AI3]	<i>A , 1...A , 3</i>	Analog input AI1...AI3
[AI4]...[AI5]	<i>A , 4...A , 5</i>	Analog input AI4...AI5 if VW3A3203 I/O extension module has been inserted
[AI Virtual 1]	<i>A , V 1</i>	Virtual analogic input 1
[PulseInput Assignment On DI5]...[PulseInput Assignment On DI6]	<i>P , 5...P , 6</i>	Digital input DI5...DI6 used as pulse input
[Flow Estimation]	<i>5 L P F</i>	Sensor less estimated flow

## [AI1 Sensor config.] *n P F I* - Menu

### Access

[Complete settings] → [Pump monitoring] → [Pump low flow Monit] → [AI1 Sensor config.]

### About This Menu

Following parameters can be accessed if:

- [PumpLF Monitoring] *P L F M* is set to [Flow] *9* or [Flow vs Speed] *9 n*, and
- [Pump Flow Assign.] *F S Z A* is set to [AI1] *A 1*.

### [AI1 Type] *A 1 T* ★

Configuration of analog input AI1.

This parameter can be accessed if [AI1 Type] *A 1 T* is set to [Voltage] *I D u*.

Setting	Code / Value	Description
[Voltage]	<i>I D u</i>	0...10 Vdc <b>Factory setting</b>
[Current]	<i>D A</i>	0...20 mA

### [AI1 min value] *u 1 L* ★

AI1 voltage scaling parameter of 0%.

This parameter can be accessed if [AI1 Type] *A 1 T* is set to [Voltage] *I D u*.

Setting	Description
0.0...10.0 V	Setting range <b>Factory setting:</b> 0.0 V

### [AI1 max value] *u 1 H* ★

AI1 voltage scaling parameter of 100%.

This parameter can be accessed if [AI1 Type] *A 1 T* is set to [Voltage] *I D u*.

Setting	Description
0.0...10.0 V	Setting range <b>Factory setting:</b> 10.0 V

### [AI1 min. value] *C 1 L* ★

AI1 current scaling parameter of 0%.

This parameter can be accessed if [AI1 Type] *A 1 T* is set to [Current] *D A*.

Setting	Description
0.0...20.0 mA	Setting range <b>Factory setting:</b> 0.0 mA

### [AI1 max. value] *C 1 H* ★

AI1 current scaling parameter of 100%.

This parameter can be accessed if [AI1 Type] *A 1 T* is set to [Current] *D A*.

Setting	Description
0.0...20.0 mA	Setting range <b>Factory setting:</b> 20.0 mA

**[A11 Lowest Process] R , I J**

Minimum process value for selected input.

Setting	Description
-32,768...32,767	Setting range. Value in application customer unit. <b>Factory setting:</b> 0

**[A11 Highest Process] R , I K**

Maximum process value for selected input.

Setting	Description
-32,768...32,767	Setting range. Value in application customer unit. <b>Factory setting:</b> 0

## [AI2 Sensor config.] *n P F 2* - Menu

### Access

[Complete settings] → [Pump monitoring] → [Pump low flow Monit] → [AI2 Sensor config.]

### About This Menu

Following parameters can be accessed if:

- [PumpLF Monitoring] *P L F n* is set to [Flow] *9* or [Flow vs Speed] *9 n*, and
- [Pump Flow Assign.] *F S 2 R* is set to [AI2] *R 1 2*.

### [AI2 Type] *R 1 2 E*

Configuration of analog input AI2.

Setting	Code / Value	Description
[Voltage]	<i>I D u</i>	0...10 Vdc <b>Factory setting</b>
[Current]	<i>D R</i>	0...20 mA
[PTC Management]	<i>P E C</i>	1 to 6 PTC (in serial)
[KTY]	<i>K E Y</i>	1 KTY84
[PT1000]	<i>I P E 3</i>	1 PT1000 connected with 2 wires
[PT100]	<i>I P E 2</i>	1 PT100 connected with 2 wires
[Water Prob]	<i>L E u E L</i>	Water level
[3PT1000]	<i>3 P E 3</i>	3 PT1000 connected with 2 wires
[3PT100]	<i>3 P E 2</i>	3 PT100 connected with 2 wires

### [AI2 min value] *u 1 L 2* ★

AI2 voltage scaling parameter of 0%.

This parameter can be accessed if [AI2 Type] *R 1 2 E* is set to [Voltage] *I D u*.

Identical to [AI1 min value] *u 1 L 1*. (see page 451)

### [AI2 max value] *u 1 H 2* ★

AI2 voltage scaling parameter of 100%.

This parameter can be accessed if [AI2 Type] *R 1 2 E* is set to [Voltage] *I D u*.

Identical to [AI1 max value] *u 1 H 1* (see page 451).

### [AI2 min. value] *C r L 2* ★

AI2 current scaling parameter of 0%.

This parameter can be accessed if [AI2 Type] *R 1 2 E* is set to [Current] *D R*.

Identical to [AI1 min. value] *C r L 1* (see page 451).

### [AI2 max. value] *C r H 2* ★

AI2 current scaling parameter of 100%.

This parameter can be accessed if [AI2 Type] *R 1 2 E* is set to [Current] *D R*.

Identical to [AI1 max. value] *C r H 1* (see page 451).

**[AI2 Lowest Process] R , 2 J**

Minimum process value for selected input.

Identical to **[AI1 Lowest Process] R , I J**. (*see page 452*)

**[AI2 Highest Process] R , 2 K**

Maximum process value for selected input.

Identical to **[AI1 Highest Process] R , I K** (*see page 452*).

## [AI3 Sensor config.] *n P F 3* - Menu

### Access

[Complete settings] → [Pump monitoring] → [Pump low flow Monit] → [AI3 Sensor config.]

### About This Menu

Following parameters can be accessed if:

- [PumpLF Monitoring] *P L F n* is set to [Flow] *9* or [Flow vs Speed] *9 n*, and
- [Pump Flow Assign.] *F S 2 n* is set to [AI3] *n , 3*.

### [AI3 Type] *n , 3 1*

Configuration of analog input AI3.

Identical to [AI2 Type] *n , 2 1* with factory setting: [Current] *0 n* (see page 453).

### [AI3 min value] *n , L 3* ★

AI3 voltage scaling parameter of 0%.

This parameter can be accessed if [AI3 Type] *n , 3 1* is set to [Voltage] *1 0 n*.

Identical to [AI1 min value] *n , L 1*. (see page 451)

### [AI3 max value] *n , H 3* ★

AI3 voltage scaling parameter of 100%.

This parameter can be accessed if [AI3 Type] *n , 3 1* is set to [Voltage] *1 0 n*.

Identical to [AI1 max value] *n , H 1* (see page 451).

### [AI3 min. value] *C r L 3* ★

AI3 current scaling parameter of 0%.

This parameter can be accessed if [AI3 Type] *n , 3 1* is set to [Current] *0 n*.

Identical to [AI1 min. value] *C r L 1* (see page 451).

### [AI3 max. value] *C r H 3* ★

AI3 current scaling parameter of 100%.

This parameter can be accessed if [AI3 Type] *n , 3 1* is set to [Current] *0 n*.

Identical to [AI1 max. value] *C r H 1* (see page 451).

### [AI3 Lowest Process] *n , 3 J*

Minimum process value for selected input.

Identical to [AI1 Lowest Process] *n , 1 J*. (see page 452)

### [AI3 Highest Process] *n , 3 K*

Maximum process value for selected input.

Identical to [AI1 Highest Process] *n , 1 K* (see page 452).

## [AI4 Sensor config.] n P F 4 - Menu

### Access

[Complete settings] → [Pump monitoring] → [Pump low flow Monit] → [AI4 Sensor config.]

### About This Menu

Following parameters can be accessed if:

- [PumpLF Monitoring] P L F n is set to [Flow] 9 or [Flow vs Speed] 9 n,
- [Pump Flow Assign.] F S 2 n is set to [AI4] n , 4, and
- VW3A3203 I/O extension module has been inserted.

### [AI4 Type] n , 4 4 ★

Configuration of analog input AI4.

Setting	Code / Value	Description
[Voltage]	1 0 u	0...10 Vdc
[Current]	0 n	0...20 mA
[Voltage +/-]	n 1 0 u	-10/+10 Vdc <b>Factory setting</b>
[PTC Management]	P E C	1 to 6 PTC (in serial)
[KTY]	K E Y	1 KTY84
[PT1000]	1 P E 3	1 PT1000 connected with 2 wires
[PT100]	1 P E 2	1 PT100 connected with 2 wires
[3 PT1000]	3 P E 3	3 PT1000 connected with 2 wires
[3 PT100]	3 P E 2	3 PT100 connected with 2 wires
[PT1000 in 3 wires]	1 P E 3 3	1 PT1000 connected with 3 wires (AI4 & AI5 only)
[PT100 in 3 wires]	1 P E 2 3	1 PT100 connected with 3 wires (AI4 & AI5 only)
[3 PT1000 in 3 wires]	3 P E 3 3	3 PT1000 connected with 3 wires (AI4 & AI5 only)
[3 PT100 in 3 wires]	3 P E 2 3	3 PT100 connected with 3 wires (AI4 & AI5 only)

### [AI4 min value] u , L 4 ★

AI4 voltage scaling parameter of 0%.

This parameter can be accessed if [AI4 Type] n , 4 4 is set to:

- [Voltage] 1 0 u, or
- [Voltage +/-] n 1 0 u.

Identical to [AI1 min value] u , L 1. (see page 451)

### [AI4 max value] u , H 4 ★

AI4 voltage scaling parameter of 100%.

This parameter can be accessed if [AI4 Type] n , 4 4 is set to:

- [Voltage] 1 0 u, or
- [Voltage +/-] n 1 0 u.

Identical to [AI1 max value] u , H 1 (see page 451).

### [AI4 min. value] C r L 4 ★

AI4 current scaling parameter of 0%.

This parameter can be accessed if [AI4 Type] n , 4 4 is set to [Current] 0 n.

Identical to [AI1 min. value] C r L 1 (see page 451).



**[AI4 max. value] C r H 4 ★**

AI4 current scaling parameter of 100%.

This parameter can be accessed if **[AI4 Type] R , 4 E** is set to **[Current] 0 R**.

Identical to **[AI1 max. value] C r H 1** (*see page 451*).

**[AI4 Lowest Process] R , 4 J**

Minimum process value for selected input.

Identical to **[AI1 Lowest Process] R , 1 J**. (*see page 452*)

**[AI4 Highest Process] R , 4 K**

Maximum process value for selected input.

Identical to **[AI1 Highest Process] R , 1 K** (*see page 452*).

## [AI5 Sensor config.] n P F 5 - Menu

### Access

[Complete settings] → [Pump monitoring] → [Pump low flow Monit] → [AI5 Sensor config.]

### About This Menu

Following parameters can be accessed if:

- [PumpLF Monitoring] P L F n is set to [Flow] 9 or [Flow vs Speed] 9 n,
- [Pump Flow Assign.] F 5 2 R is set to [AI5] R , 5, and
- VW3A3203 I/O extension module has been inserted.

### [AI5 Type] R , 5 E ★

Configuration of analog input AI5.

Identical to [AI4 Type] R , 4 E . (see page 456)

### [AI5 min value] u , L 5 ★

AI5 voltage scaling parameter of 0%.

This parameter can be accessed if [AI5 Type] R , 5 E is set to:

- [Voltage] 1 0 u, or
- [Voltage +/-] n 1 0 u.

Identical to [AI1 min value] u , L 1 . (see page 451)

### [AI5 max value] u , H 5 ★

AI5 voltage scaling parameter of 100%.

This parameter can be accessed if [AI5 Type] R , 5 E is set to:

- [Voltage] 1 0 u, or
- [Voltage +/-] n 1 0 u.

Identical to [AI1 max value] u , H 1 (see page 451).

### [AI5 min. value] C r L 5 ★

AI5 current scaling parameter of 0%.

This parameter can be accessed if [AI5 Type] R , 5 E is set to [Current] o R.

Identical to [AI1 min. value] C r L 1 (see page 451).

### [AI5 max. value] C r H 5 ★

AI5 current scaling parameter of 100%.

This parameter can be accessed if [AI5 Type] R , 5 E is set to [Current] o R.

Identical to [AI1 max. value] C r H 1 (see page 451).

### [AI5 Lowest Process] R , 5 J

Minimum process value for selected input.

Identical to [AI1 Lowest Process] R , 1 J . (see page 452)

### [AI5 Highest Process] R , 5 K

Maximum process value for selected input.

Identical to [AI1 Highest Process] R , 1 K (see page 452).

## [DI5 Pulse Sensor Config] *n P F B* - Menu

### Access

[Complete settings] → [Pump monitoring] → [Pump low flow Monit] → [DI5 Pulse Sensor Config]

### About This Menu

Following parameters can be accessed if:

- [PumpLF Monitoring] *P L F n* is set to [Flow] *9* or [Flow vs Speed] *9 n*, and
- [Pump Flow Assign.] *F S 2 A* is set to [DI5 PulseInput Assignment] *P , 5*.

### [PulseInput DI5 Low Freq] *P , L 5*

Minimum pulse input.

Pulse input DI5: frequency for 0% of the equivalent analog signal.

Setting	Description
0.00...30,000.00 Hz	Setting range <b>Factory setting:</b> 0 Hz

### [PulseInput DI5 High Freq] *P , H 5*

Maximum pulse input.

Pulse input DI5: frequency for 100% of the equivalent analog signal.

Setting	Description
0.00...30.00 kHz	Setting range <b>Factory setting:</b> 30.00 kHz

### [DI5 Min Process] *P , 5 J*

Minimum process value for selected input.

Setting	Description
-32,768...32,767	Setting range <b>Factory setting:</b> 0

### [DI5 Max Process] *P , 5 K*

Maximum process value for selected input.

Setting	Description
-32,768...32,767	Setting range <b>Factory setting:</b> 0

## [DI6 Pulse Sensor Config] *n P F 9* - Menu

### Access

[Complete settings] → [Pump monitoring] → [High flow monitoring] → [DI6 Pulse Sensor Config]

### About This Menu

Following parameters can be accessed if:

- [PumpLF Monitoring] *P L F 0* is set to [Flow] *9* or [Flow vs Speed] *9 n*, and
- [Pump Flow Assign.] *F S 2 A* is set to [DI6 PulseInput Assignment] *P , 6*.

### [PulseInput DI6 Low Freq] *P , L 6*

Minimum pulse input.

Pulse input DI5: frequency for 0% of the equivalent analog signal.

Setting	Description
0.00...30,000.00 Hz	Setting range <b>Factory setting:</b> 0 Hz

### [PulseInput DI6 High Freq] *P , H 6*

Maximum pulse input.

Pulse input DI5: frequency for 100% of the equivalent analog signal.

Setting	Description
0.00...30.00 kHz	Setting range <b>Factory setting:</b> 30.00 kHz

### [DI6 Min Process] *P , 6 J*

Minimum process value for selected input.

Setting	Description
-32,768...32,767	Setting range <b>Factory setting:</b> 0

### [DI6 Max Process] *P , 6 K*

Maximum process value for selected input.

Setting	Description
-32,768...32,767	Setting range <b>Factory setting:</b> 0

## [AIV1 Sensor config.] *n P V I* - Menu

### Access

[Complete settings] → [Pump functions] → [Pump low flow Monit] → [AIV1 Sensor config.]

### About This Menu

Following parameters can be accessed if:

- [PumpLF Monitoring] *P L F M* is set to [Flow] *9* or [Flow vs Speed] *9 n*, and
- [Pump Flow Assign.] *F S Z A* is set to [AI Virtual 1] *A I V I*.

### [AIV1 Channel Assignment] *A I C I*

Channel assignment for virtual analog input AIV1.

Setting	Code / Value	Description
[Not Configured]	<i>n a</i>	Not assigned <b>Factory setting</b>
[Ref. Freq-Modbus]	<i>M d b</i>	Reference frequency via Modbus
[Ref. Freq-CANopen]	<i>C A n</i>	Reference frequency via CANopen if a CANopen module has been inserted
[Ref. Freq-Com. Module]	<i>n E t</i>	Reference frequency via fieldbus module if a fieldbus module has been inserted
[Embedded Ethernet]	<i>E t H</i>	Embedded Ethernet

### [AIV1 Lowest Process] *A V I J*

AI virtual x: minimum process value.

Setting	Description
-32,767...32,767	Setting range <b>Factory setting:</b> 0

### [AIV1 Highest Process] *A V I K*

AI virtual x: maximum process value.

Setting	Description
-32,767...32,767	Setting range <b>Factory setting:</b> 0

## [Pump low flow Monit] *PLF* - Menu

### Access

[Complete settings] → [Pump monitoring] → [Pump low flow Monit]

### About This Menu

During the setup of the function, it is necessary to perform measurements at no or low flow but always with water in the system.

### [PumpLF Min Level] *PLFL* ★

Pump low flow minimum flow level.

This parameter can be accessed if [PumpLF Monitoring] *PLFN* is set to [Flow] *9* or [Flow vs Speed] *9n*.

Setting ( )	Description
0...32,767	Setting range according to [Flow rate unit] <i>SUFr</i> . Factory setting: 0

### [Power Estim Value] *oPrW* ★

Motor mechanical power estimation. It can be used to set [Low Power] *nFLP* and [High Power] *nFHP* values.

This parameter can be accessed if [PumpLF Monitoring] *PLFN* is set to [No Flow Power] *nF*.

Setting	Description
According to drive rating	Setting range Factory setting: _

### [Low Speed] *nFLS* ★

No flow low speed.

This parameter can be accessed if [PumpLF Monitoring] *PLFN* is set to [No Flow Power] *nF*.

Setting ( )	Description
0.0...500.0 Hz	Setting range Factory setting: 0.0 Hz

### [High Speed] *nFHS* ★

No flow high speed.

This parameter can be accessed if [PumpLF Monitoring] *PLFN* is set to [No Flow Power] *nF*.

Setting ( )	Description
0.0...500.0 Hz	Setting range Factory setting: 0.0 Hz

### [Low Power] *nFLP* ★

No flow low power.

This parameter can be accessed if [PumpLF Monitoring] *PLFN* is set to [No Flow Power] *nF*.

Setting ( )	Description
0...32,767	Setting range Factory setting: 0

**[High Power] n F H P ★**

No flow high power.

This parameter can be accessed if **[PumpLF Monitoring] P L F Π** is set to **[No Flow Power] n F**.

Setting (↻)	Description
0...32,767	Setting range <b>Factory setting:</b> 0

**[PumpLF Power Factor] P L F X ★**

Pump low flow power factor.

This parameter can be accessed if **[PumpLF Monitoring] P L F Π** is set to **[No Flow Power] n F**.

Setting (↻)	Description
100...500%	Setting range <b>Factory setting:</b> 110%

**[PumpLF ActivDelay] P L F A ★**

Pump low flow monitoring activation delay after the pump has been started.

This parameter can be accessed if **[PumpLF Monitoring] P L F Π** is not set to **[No] n o**.

Setting (↻)	Description
0...3,600 s	Setting range <b>Factory setting:</b> 10 s

**[PumpLF Error Delay] P L F d ★**

Pump low flow detected error delay.

This parameter can be accessed if **[PumpLF Monitoring] P L F Π** is not set to **[No] n o**.

Setting (↻)	Description
0...3,600 s	Setting range <b>Factory setting:</b> 10 s

**[PumpLF Error Resp] P L F b ★**

Pump low flow monitoring function response to a detected error.

This parameter can be accessed if **[PumpLF Monitoring] P L F Π** is not set to **[No] n o**.

Setting	Code / Value	Description
<b>[Ignore]</b>	n o	Detected error ignored
<b>[Freewheel Stop]</b>	Y E 5	Freewheel stop
<b>[Per STT]</b>	S E E	Stop according to <b>[Type of stop] S E E</b> parameter but without an error triggered after stop
<b>[Fallback Speed]</b>	L F F	Change to fallback speed, maintained as long as the detected error persists and the run command has not been removed <sup>(1)</sup>
<b>[Ramp stop]</b>	r Π P	Stop on ramp <b>Factory setting</b>
<b>1</b> Because, in this case, the detected error does not trigger a stop, it is recommended to assign a relay or logic output to its indication.		

**[PumpLF Restart Delay] *PLFr* ★**

Pump low flow restart delay.

This parameter can be accessed if **[PumpLF Monitoring] *PLFΠ*** is not set to **[No] *na***.

Setting 	Description
0...3,600 s	Setting range <b>Factory setting:</b> 0 s



## Section 7.24

### [Pump monitoring] - [Pump thermal monit]

#### [Pump thermal monit] $\hookrightarrow$ P P - Menu

##### Access

[Complete settings]  $\rightarrow$  [Pump monitoring]  $\rightarrow$  [Pump thermal monit]

##### About This Menu

The thermal monitoring function helps to prevent against high temperature by monitoring the real temperature by the drive.

PTC, PT100, PT1000, and KTY84 thermal probes are supported by this function.

The function gives the possibility to manage 2 levels of monitoring:

- A Warning level: the drive triggers an event without stopping the application.
- An Error level: the drive triggers an event and stop the application.

The thermal probe is monitored for the following detected error:

- Overheating
- Probe break (loss of signal)
- Probe short-circuit

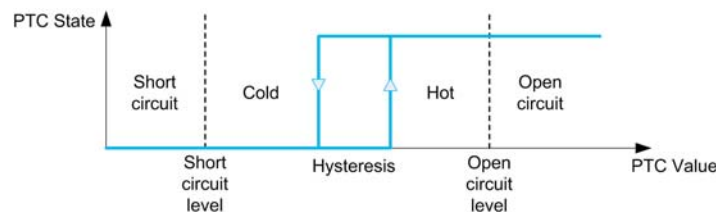

##### Activation

[Alx Th Monitoring]  $\hookrightarrow$  H X 5 allows you to activate the thermal monitoring on the related analog input:

- [No] n o: the function is disabled
- [Yes] y e 5: the thermal monitoring is enabled on the related Alx.

##### Type of Thermal Probe Selection

[Alx Type] H i X 5 allows you to select the type of thermal sensor(s) connected on the related analog input:

- [No] n o: no sensor
- [PTC Management] P e c: 1 to 6 PTC (in serial) is used
- [KTY] K e y: 1 KTY84 is used
- [PT100] i P e 2: 1 PT100 connected with 2 wires is used
- [3PT100] 3 P e 2: 3 PT100 connected with 2 wires are used
- [PT1000] i P e 3: 1 PT1000 connected with 2 wires is used
- [3PT1000] 3 P e 3: 3 PT1000 connected with 2 wires are used
- [PT100 in 3 wires] i P e 2 3: 1 PT100 connected with 3 wires is used (AI4 & AI5 only)
- [3PT100 in 3 wires] 3 P e 2 3: 3 PT100 connected with 3 wires are used (AI4 & AI5 only)
- [PT1000 in 3 wires] i P e 3 3: 1 PT1000 connected with 3 wires is used (AI4 & AI5 only)
- [3PT1000 in 3 wires] 3 P e 3 3: 3 PT1000 connected with 3 wires are used (AI4 & AI5 only)

2-wire thermal probes are supported on analog input 2 to analog input 5.

3-wire thermal probes are supported on analog input 4 and analog input 5. These inputs are available with the I/O extension option module.

If the probe is far from the drive, the 3-wire connection is recommended as compared to a 2-wire connection.

**NOTE:** In case of 3 serial probes, the drive monitors the average probe values.

### Wiring for PT100 and PT1000 Probes

For 2-wire probes, the following wirings are possible:



For 3-wire probes, the following wirings are possible:

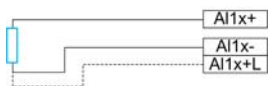

### [AI2 Th Monitoring] E H 2 5

Activation of the thermal monitoring on AI2.

Setting	Code / Value	Description
[No]	n o	No <b>Factory setting</b>
[YES]	y e s	Yes

### [AI2 Type] R 1 2 E ★

AI2 assignment.

This parameter can be accessed if [AI2 Th Monitoring] E H 2 5 is not set to [No] n o.

Setting	Code / Value	Description
[Voltage]	1 0 v	0-10 Vdc <b>Factory setting</b>
[Current]	0 a	0-20 mA
[PTC Management]	p t c	1 to 6 PTC (in serial)
[KTY]	k t y	1 KTY84
[PT1000]	1 p t 3	1 PT1000 connected with 2 wires
[PT100]	1 p t 2	1 PT100 connected with 2 wires
[Water Prob]	l e v e l	Water level
[3PT1000]	3 p t 3	3 PT1000 connected with 2 wires
[3PT100]	3 p t 2	3 PT100 connected with 2 wires

**[AI2 Th Error Resp] Ɨ H 2 Ɓ ★**

Thermal monitoring response to a detected error for AI2.

This parameter can be accessed if **[AI2 Type] H , 2 Ɨ** is not set to

- **[Voltage] 1 0 Ʃ**, or
- **[Current] 0 H**.

Setting	Code / Value	Description
<b>[Ignore]</b>	n 0	Detected error ignored
<b>[Freewheel Stop]</b>	Ƴ E 5	Freewheel stop
<b>[Per STT]</b>	5 Ɨ Ɨ	Stop according to <b>[Type of stop] 5 Ɨ Ɨ</b> parameter but without an error triggered after stop
<b>[Fallback Speed]</b>	L F F	Change to fallback speed, maintained as long as the detected error persists and the run command has not been removed <sup>(1)</sup>
<b>[Ramp stop]</b>	r 0 P	Stop on ramp <b>Factory setting</b>

1 Because, in this case, the detected error does not trigger a stop, it is recommended to assign a relay or logic output to its indication.

**[AI2 Th Error Level] Ɨ H 2 F ★**

Error detection level for AI2.

This parameter can be accessed if **[AI2 Type] H , 2 Ɨ** is not set to:

- **[Voltage] 1 0 Ʃ**, or
- **[Current] 0 H**, or
- **[PTC Management] P Ɨ Ɨ**.

Setting ( )	Description
-15.0...200.0°C	Setting range <b>Factory setting:</b> 110.0°C

**[AI2 Th Warn Level] Ɨ H 2 H ★**

Warning level for AI2.

This parameter can be accessed if **[AI2 Type] H , 2 Ɨ** is not set to:

- **[Voltage] 1 0 Ʃ**, or
- **[Current] 0 H**, or
- **[PTC Management] P Ɨ Ɨ**.

Setting ( )	Description
-15.0...200.0°C	Setting range <b>Factory setting:</b> 90.0°C

**[AI2 Th Value] Ɨ H 2 Ʃ ★**

AI2 thermal value.

This parameter can be accessed if **[AI2 Type] H , 2 Ɨ** is not set to:

- **[Voltage] 1 0 Ʃ**, or
- **[Current] 0 H**, or
- **[PTC Management] P Ɨ Ɨ**.

Setting	Description
-15.0...200.0°C	Setting range <b>Factory setting:</b> _

**[AI3 Th Monitoring] 𐄂 H 𐄂 5**

Activation of the thermal monitoring on AI3.

Setting	Code / Value	Description
[No]	n 𐄂	No <b>Factory setting</b>
[YES]	𐄂 E 5	Yes

**[AI3 Type] 𐄂 , 𐄂 𐄂 ★**

AI3 assignment.

This parameter can be accessed if **[AI3 Th Monitoring] 𐄂 H 𐄂 5** is not set to **[No] n 𐄂**.

Identical to **[AI2 Type] 𐄂 , 𐄂 𐄂** (see page 466) with factory setting: **[Current] 𐄂 𐄂**.

**[AI3 Th Error Resp] 𐄂 H 𐄂 𐄂 ★**

Thermal monitoring response to a detected error for AI3.

This parameter can be accessed if **[AI3 Type] 𐄂 , 𐄂 𐄂** is not set to:

- **[Voltage] 1 𐄂 𐄂**, or
- **[Current] 𐄂 𐄂**, or

Setting	Code / Value	Description
[Ignore]	n 𐄂	Detected error ignored
[Freewheel Stop]	𐄂 E 5	Freewheel stop
[Per STT]	5 𐄂 𐄂	Stop according to <b>[Type of stop] 5 𐄂 𐄂</b> parameter but without an error triggered after stop
[Fallback Speed]	L F F	Change to fallback speed, maintained as long as the detected error persists and the run command has not been removed <sup>(1)</sup>
[Ramp stop]	r 𐄂 𐄂	Stop on ramp <b>Factory setting</b>
<p><b>1</b> Because, in this case, the detected error does not trigger a stop, it is recommended to assign a relay or logic output to its indication.</p>		

**[AI3 Th Error Level] 𐄂 H 𐄂 F ★**

Error detection level for AI3.

This parameter can be accessed if **[AI3 Type] 𐄂 , 𐄂 𐄂** is not set to:

- **[Voltage] 1 𐄂 𐄂**, or
- **[Current] 𐄂 𐄂**, or
- **[PTC Management] P 𐄂 𐄂**.

Setting ( )	Description
-15.0...200.0°C	Setting range <b>Factory setting:</b> 110.0°C

**[AI3 Th Warn Level] 𐄂 H 𐄂 𐄂 ★**

Warning level for AI3.

This parameter can be accessed if **[AI3 Type] 𐄂 , 𐄂 𐄂** is not set to:

- **[Voltage] 1 𐄂 𐄂**, or
- **[Current] 𐄂 𐄂**, or
- **[PTC Management] P 𐄂 𐄂**.

Setting ( )	Description
-15.0...200.0°C	Setting range <b>Factory setting:</b> 90.0°C

**[AI3 Th Value] Ɨ H 3 ƭ ★**

AI3 thermal value.

This parameter can be accessed if **[AI3 Type] Ɨ ƭ Ɨ** is not set to:

- **[Voltage] 1 0 ƭ**, or
- **[Current] 0 Ɨ**, or
- **[PTC Management] Ƒ Ɨ Ɨ**.

Setting	Description
-15.0...200.0°C	Setting range Factory setting: _

**[AI4 Th Monitoring] Ɨ H 4 5 ★**

Activation of the thermal monitoring on AI4.

This parameter can be accessed if VW3A3203 relay output option module has been inserted.

Setting	Code / Value	Description
<b>[No]</b>	<i>n 0</i>	No Factory setting
<b>[YES]</b>	<i>Ƨ Ɨ 5</i>	Yes

**[AI4 Type] Ɨ ƭ 4 Ɨ ★**

AI4 assignment.

This parameter can be accessed if **[AI4 Th Monitoring] Ɨ H 4 5** is not set to **[No] n 0**.

Setting	Code / Value	Description
<b>[Voltage]</b>	<i>1 0 ƭ</i>	0-10 Vdc
<b>[Current]</b>	<i>0 Ɨ</i>	0-20 mA
<b>[Voltage +/-]</b>	<i>n 1 0 ƭ</i>	-10/+10 Vdc Factory setting
<b>[PTC Management]</b>	<i>Ƒ Ɨ Ɨ</i>	1 to 6 PTC (in serial)
<b>[KTY]</b>	<i>K Ɨ Ƨ</i>	1 KTY84
<b>[PT1000]</b>	<i>1 Ƒ Ɨ 3</i>	1 PT1000 connected with 2 wires
<b>[PT100]</b>	<i>1 Ƒ Ɨ 2</i>	1 PT100 connected with 2 wires
<b>[3 PT1000]</b>	<i>3 Ƒ Ɨ 3</i>	3 PT1000 connected with 2 wires
<b>[3 PT100]</b>	<i>3 Ƒ Ɨ 2</i>	3 PT100 connected with 2 wires
<b>[PT1000 in 3 wires]</b>	<i>1 Ƒ Ɨ 3 3</i>	1 PT1000 connected with 3 wires (AI4 & AI5 only)
<b>[PT100 in 3 wires]</b>	<i>1 Ƒ Ɨ 2 3</i>	1 PT100 connected with 3 wires (AI4 & AI5 only)
<b>[3 PT1000 in 3 wires]</b>	<i>3 Ƒ Ɨ 3 3</i>	3 PT1000 connected with 3 wires (AI4 & AI5 only)
<b>[3 PT100 in 3 wires]</b>	<i>3 Ƒ Ɨ 2 3</i>	3 PT100 connected with 3 wires (AI4 & AI5 only)

**[AI4 Th Error Resp] E H 4 B ★**

Thermal monitoring response to a detected error for AI4.

This parameter can be accessed if **[AI4 Type] R , 4 E** is not set to

- **[Voltage] I D U**, or
- **[Current] D R**.

Setting	Code / Value	Description
<b>[Ignore]</b>	n o	Detected error ignored
<b>[Freewheel Stop]</b>	Y E S	Freewheel stop
<b>[Per STT]</b>	S E E	Stop according to <b>[Type of stop] S E E</b> parameter but without an error triggered after stop
<b>[Fallback Speed]</b>	L F F	Change to fallback speed, maintained as long as the detected error persists and the run command has not been removed <sup>(1)</sup>
<b>[Ramp stop]</b>	r P P	Stop on ramp <b>Factory setting</b>
<p><b>1</b> Because, in this case, the detected error does not trigger a stop, it is recommended to assign a relay or logic output to its indication.</p>		

**[AI4 Th Error Level] E H 4 F ★**

Error detection level for AI4.

This parameter can be accessed if **[AI4 Type] R , 4 E** is not set to:

- **[Voltage] I D U**, or
- **[Current] D R**, or
- **[PTC Management] P E C**.

Setting (°)	Description
-15.0...200.0°C	Setting range <b>Factory setting:</b> 110.0°C

**[AI4 Th Warn Level] E H 4 R ★**

Warning level for AI4.

This parameter can be accessed if **[AI4 Type] R , 4 E** is not set to:

- **[Voltage] I D U**, or
- **[Current] D R**, or
- **[PTC Management] P E C**.

Setting (°)	Description
-15.0...200.0°C	Setting range <b>Factory setting:</b> 90.0°C

**[AI4 Th Value] E H 4 U ★**

AI4 thermal value.

This parameter can be accessed if **[AI4 Type] R , 4 E** is not set to:

- **[Voltage] I D U**, or
- **[Current] D R**, or
- **[PTC Management] P E C**.

Setting	Description
-15.0...200.0°C	Setting range <b>Factory setting:</b> _

**[AI5 Th Monitoring] E H 5 5 ★**

Activation of the thermal monitoring on AI5.

This parameter can be accessed if VW3A3203 relay output option module has been inserted.

Setting	Code / Value	Description
[No]	n o	No <b>Factory setting</b>
[YES]	Y E 5	Yes

**[AI5 Type] R , 5 E ★**

AI5 assignment.

This parameter can be accessed if **[AI5 Th Monitoring] E H 5 5** is not set to **[No] n o**.

Identical to **[AI4 Type] R , 4 E** (see page 469).

**[AI5 Th Error Resp] E H 5 b ★**

Thermal monitoring response to a detected error for AI5.

This parameter can be accessed if **[AI5 Type] R , 5 E** is not set to

- **[Voltage] I D u**, or
- **[Current] D R**.

Setting	Code / Value	Description
[Ignore]	n o	Detected error ignored
[Freewheel Stop]	Y E 5	Freewheel stop
[Per STT]	5 E E	Stop according to <b>[Type of stop] 5 E E</b> parameter but without an error triggered after stop
[Fallback Speed]	L F F	Change to fallback speed, maintained as long as the detected error persists and the run command has not been removed <sup>(1)</sup>
[Ramp stop]	r P P	Stop on ramp <b>Factory setting</b>
<b>1</b> Because, in this case, the detected error does not trigger a stop, it is recommended to assign a relay or logic output to its indication.		

**[AI5 Th Error Level] E H 5 F ★**

Error detection level for AI5.

This parameter can be accessed if **[AI5 Type] R , 5 E** is not set to:

- **[Voltage] I D u**, or
- **[Current] D R**, or
- **[PTC Management] P E C**.

Setting (°)	Description
-15.0...200.0°C	Setting range <b>Factory setting:</b> 110.0°C

**[AI5 Th Warn Level] E H 5 R ★**

Warning level for AI5.

This parameter can be accessed if **[AI5 Type] R , 5 E** is not set to:

- **[Voltage] I D u**, or
- **[Current] D R**, or
- **[PTC Management] P E C**.

Setting (°)	Description
-15.0...200.0°C	Setting range <b>Factory setting:</b> 90.0°C

**[AI5 Th Value]  $\text{E H S } \mu$** 

AI5 thermal value.

This parameter can be accessed if **[AI5 Type]  $R, S E$**  is not set to:

- **[Voltage]  $I D \mu$** , or
- **[Current]  $D R$** , or
- **[PTC Management]  $P E C$** .

Setting	Description
-15.0...200.0°C	Setting range Factory setting: _



---

## Section 7.25

### [Pump monitoring] - [Inlet pressure monitori..]

---

#### What Is in This Section?

This section contains the following topics:

Topic	Page
[Inlet pressure monitoring] , <i>PP</i> - Menu	474
[AI1 sensor config.] , <i>PA 1</i> - Menu	476
[AI2 sensor config.] , <i>PA 2</i> - Menu	478
[AI3 sensor config.] , <i>PA 3</i> - Menu	480
[AI4 sensor config.] , <i>PA 4</i> - Menu	481
[AI5 sensor config.] , <i>PA 5</i> - Menu	483
[AIV1 sensor config.] , <i>PU 1</i> - Menu	484
[Inlet pressure monitoring] , <i>PP</i> - Menu	485

## [Inlet pressure monitoring] , PP - Menu

### Access

[Complete settings] → [Pump monitoring] → [Inlet pressure monitoring]

### About This Menu

This function helps to detect an inlet low-pressure situation.

This monitoring function is at station level and not a pump level only.

This function requires a pressure sensor to monitor the inlet pressure of the system.

In case of low inlet pressure situation, this function:

- Triggers a warning and reduces the outlet pressure set point within a predefined range in order to maintain the inlet pressure at an acceptable level. The inlet pressure compensation applies only to pressure controlled application.
- Triggers a detected error signal if, despite of this pressure set point reduction, the inlet pressure feedback is less than the minimum acceptable value configured.

The inlet pressure monitoring function can be used for mono-pump or multi-pump stations.

This is an example of a station architecture:

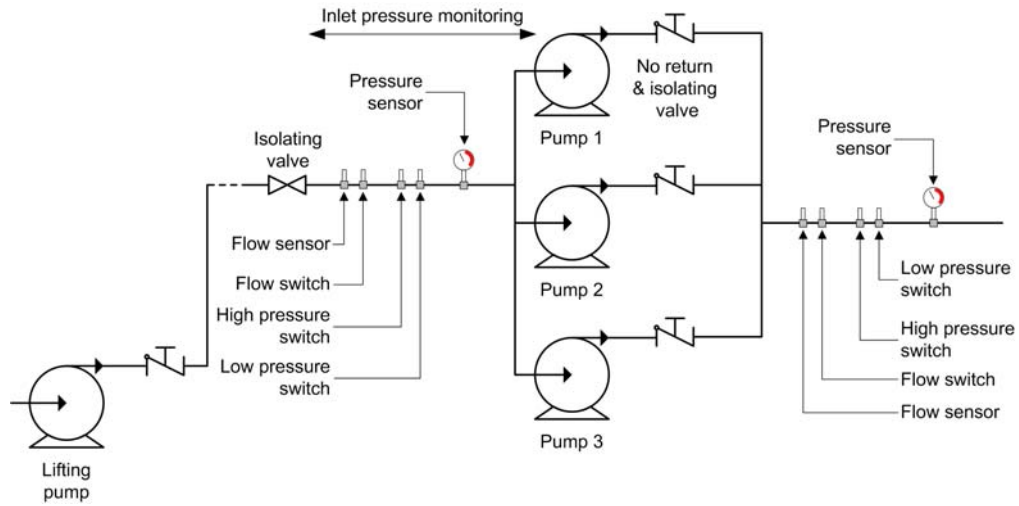

### Monitoring Diagram

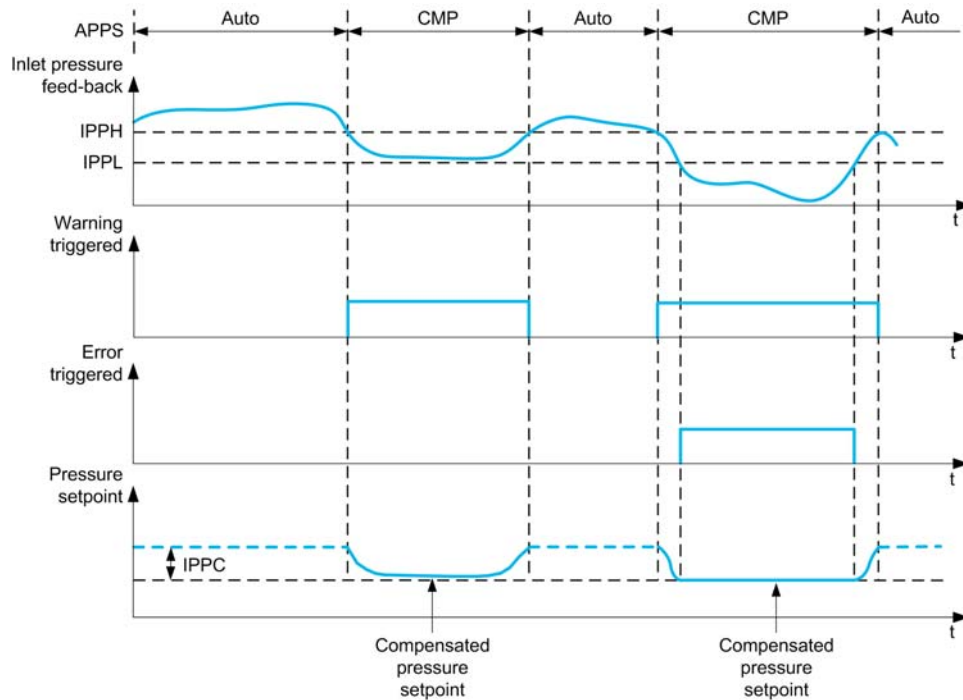

When the inlet pressure feedback is lower than **[InletPres High Thd]** , *PPH* , a warning **[InletPres Warning]** , *PPA* is triggered. In case of a pressure controlled application, the pressure set point is reduced according to **[InletPres Max Comp]** , *PPC* .

When the inlet pressure feedback is less than **[InletPres High Thd]** , *PLL* , a detected error **[Inlet Pressure Error]** , *PPF* is triggered. The application follows the **[InletPresErrorResp]** , *PPb* defined behavior.

### **[InletPres Monitoring]** , *PPN*

Inlet pressure monitoring mode.

Setting	Code / Value	Description
<b>[No]</b>	<i>no</i>	Not activated <b>Factory setting</b>
<b>[Warning]</b>	<i>YES</i>	Warning monitoring activated
<b>[Compensation]</b>	<i>COMP</i>	Warning and compensation activated

### **[InletPres Assign]** *PSIA* ★

Inlet pressure sensor assignment.

This parameter can be accessed if **[InletPres Monitoring]** , *PPN* is not set to **[No]** *no* .

Setting	Code / Value	Description
<b>[Not Configured]</b>	<i>no</i>	Not assigned <b>Factory setting</b>
<b>[AI1]...[AI3]</b>	<i>A , 1...A , 3</i>	Analog input AI1...AI3
<b>[AI4]...[AI5]</b>	<i>A , 4...A , 5</i>	Analog input AI4...AI5 if VW3A3203 I/O extension module has been inserted
<b>[AI Virtual 1]</b>	<i>A , V 1</i>	Virtual analogic input 1

**[AI1 sensor config.] , P P I - Menu**

**Access**

[Complete settings] → [Pump monitoring] → [Inlet pressure monitoring] → [AI1 sensor config.]

**About This Menu**

Following parameters can be accessed if:

- [InletPres Monitoring] , P P I is not set to [No] n o , and
- [InletPres Assign] P S I R is set to [AI1] R , I .

**[AI1 Type] R , I E**

Configuration of analog input AI1.

Setting	Code / Value	Description
[Voltage]	I D u	0-10 Vdc <b>Factory setting</b>
[Current]	D R	0-20 mA

**[AI1 min value] u , L I ★**

AI1 voltage scaling parameter of 0%.

This parameter can be accessed if [AI1 Type] R , I E is set to [Voltage] I D u .

Setting	Description
0.0...10.0 Vdc	Setting range <b>Factory setting:</b> 0.0 Vdc

**[AI1 max value] u , H I ★**

AI1 voltage scaling parameter of 100%.

This parameter can be accessed if [AI1 Type] R , I E is set to [Voltage] I D u .

Setting	Description
0.0...10.0 Vdc	Setting range <b>Factory setting:</b> 10.0 Vdc

**[AI1 min. value] C r L I ★**

AI1 current scaling parameter of 0%.

This parameter can be accessed if [AI1 Type] R , I E is set to [Current] D R .

Setting	Description
0.0...20.0 mA	Setting range <b>Factory setting:</b> 0.0 mA

**[AI1 max. value] C r H I ★**

AI1 current scaling parameter of 100%.

This parameter can be accessed if [AI1 Type] R , I E is set to [Current] D R .

Setting	Description
0.0...20.0 mA	Setting range <b>Factory setting:</b> 20.0 mA

**[A11 Lowest Process]R , I J**

Minimum process value for selected input.

Setting	Description
-32,768...32,767	Setting range. Value in application customer unit. <b>Factory setting:</b> 0

**[A11 Highest Process]R , I K**

Maximum process value for selected input.

Setting	Description
-32,768...32,767	Setting range. Value in application customer unit. <b>Factory setting:</b> 0

**[AI2 sensor config.] , P R 2 - Menu**

**Access**

[Complete settings] → [Pump monitoring] → [Inlet pressure monitoring] → [AI2 sensor config.]

**About This Menu**

Following parameters can be accessed if:

- [InletPres Monitoring] , P P Π is not set to [No] n o , and
- [InletPres Assign] P S I R is set to [AI2] R , 2 .

**[AI2 Type] R , 2 E**

Configuration of analog input AI2.

Setting	Code / Value	Description
[Voltage]	1 0 u	0-10 Vdc <b>Factory setting</b>
[Current]	0 R	0-20 mA
[PTC Management]	P E C	1 to 6 PTC (in serial)
[KTY]	K E Y	1 KTY84
[PT1000]	1 P E 3	1 PT1000 connected with 2 wires
[PT100]	1 P E 2	1 PT100 connected with 2 wires
[Water Prob]	L E u E L	Water level
[3PT1000]	3 P E 3	3 PT1000 connected with 2 wires
[3PT100]	3 P E 2	3 PT100 connected with 2 wires

**[AI2 min value] u , L 2 ★**

AI2 voltage scaling parameter of 0%.

This parameter can be accessed if [AI2 Type] R , 2 E is set to [Voltage] 1 0 u .

Identical to [AI1 min value] u , L 1 (see page 476).

**[AI2 max value] u , H 2 ★**

AI2 voltage scaling parameter of 100%.

This parameter can be accessed if [AI2 Type] R , 2 E is set to [Voltage] 1 0 u .

Identical to [AI1 max value] u , H 1 (see page 476).

**[AI2 min. value] C r L 2 ★**

AI2 current scaling parameter of 0%.

This parameter can be accessed if [AI2 Type] R , 2 E is set to [Current] 0 R .

Identical to [AI1 min. value] C r L 1 (see page 476).

**[AI2 max. value] C r H 2 ★**

AI2 current scaling parameter of 100%.

This parameter can be accessed if [AI2 Type] R , 2 E is set to [Current] 0 R .

Identical to [AI1 max. value] C r H 1 (see page 476).

**[AI2 Lowest Process] *R* , *2 J***

Minimum process value for selected input.

Identical to **[AI1 Lowest Process] *R* , *1 J*** (*see page 477*).

**[AI2 Highest Process] *R* , *2 K***

Maximum process value for selected input.

Identical to **[AI1 Highest Process] *R* , *1 K*** (*see page 477*).

## [AI3 sensor config.] , P R 3 - Menu

### Access

[Complete settings] → [Pump monitoring] → [Inlet pressure monitoring] → [AI3 sensor config.]

### About This Menu

Following parameters can be accessed if:

- [InletPres Monitoring] , P P Π is not set to [No] n o , and
- [InletPres Assign] P S I R is set to [AI3] R , 3 .

### [AI3 Type] R , 3 E

Configuration of analog input AI3.

Identical to [AI2 Type] R , 2 E with factory setting: [Current] D R. (see page 478)

### [AI3 min value] u , L 3 ★

AI3 voltage scaling parameter of 0%.

This parameter can be accessed if [AI3 Type] R , 3 E is set to [Voltage] I D u .

Identical to [AI1 min value] u , L 1 (see page 476).

### [AI3 max value] u , H 3 ★

AI3 voltage scaling parameter of 100%.

This parameter can be accessed if [AI3 Type] R , 3 E is set to [Voltage] I D u .

Identical to [AI1 max value] u , H 1 (see page 476).

### [AI3 min. value] C r L 3 ★

AI3 current scaling parameter of 0%.

This parameter can be accessed if [AI3 Type] R , 3 E is set to [Current] o R .

Identical to [AI1 min. value] C r L 1 (see page 476) with factory setting: [Current] D R.

### [AI3 max. value] C r H 3 ★

AI3 current scaling parameter of 100%.

This parameter can be accessed if [AI3 Type] R , 3 E is set to [Current] o R .

Identical to [AI1 max. value] C r H 1 (see page 476) with factory setting: [Current] D R.

### [AI3 Lowest Process] R , 3 J

Minimum process value for selected input.

Identical to [AI1 Lowest Process] R , 1 J (see page 477).

### [AI3 Highest Process] R , 3 K

Maximum process value for selected input.

Identical to [AI1 Highest Process] R , 1 K (see page 477).



**[AI4 sensor config.] , P R 4 - Menu****Access**

[Complete settings] → [Pump monitoring] → [Inlet pressure monitoring] → [AI4 sensor config.]

**About This Menu**

Following parameters can be accessed if:

- [InletPres Monitoring] , P P Π is not set to [No] n o, and
- [InletPres Assign] P S I R is set to [AI4] R , 4.

**[AI4 Type] R , 4 E ★**

Configuration of AI4.

This parameter can be accessed if VW3A3203 I/O extension module has been inserted.

Setting	Code / Value	Description
[Voltage]	I D u	0-10 Vdc
[Current]	D R	0-20 mA
[Voltage +/-]	n I D u	-10/+10 Vdc <b>Factory setting</b>
[PTC Management]	P E C	1 to 6 PTC (in serial)
[KTY]	K E Y	1 KTY84
[PT1000]	I P E 3	1 PT1000 connected with 2 wires
[PT100]	I P E 2	1 PT100 connected with 2 wires
[3 PT1000]	3 P E 3	3 PT1000 connected with 2 wires
[3 PT100]	3 P E 2	3 PT100 connected with 2 wires
[PT1000 in 3 wires]	I P E 3 3	1 PT1000 connected with 3 wires (AI4 & AI5 only)
[PT100 in 3 wires]	I P E 2 3	1 PT100 connected with 3 wires (AI4 & AI5 only)
[3 PT1000 in 3 wires]	3 P E 3 3	3 PT1000 connected with 3 wires (AI4 & AI5 only)
[3 PT100 in 3 wires]	3 P E 2 3	3 PT100 connected with 3 wires (AI4 & AI5 only)

**[AI4 min value] u , L 4 ★**

AI4 voltage scaling parameter of 0%.

Identical to [AI1 min value] u , L 1 (see page 476).

**[AI4 max value] u , H 4 ★**

AI4 voltage scaling parameter of 100%.

Identical to [AI1 max value] u , H 1 (see page 476).

**[AI4 min. value] C r L 4 ★**

AI4 current scaling parameter of 0%.

Identical to [AI1 min. value] C r L 1 (see page 476) with factory setting: [Current] D R.

**[AI4 max. value] C r H 4 ★**

AI4 current scaling parameter of 100%.

Identical to [AI1 max. value] C r H 1 with factory setting: [Current] D R (see page 476).

**[AI4 Lowest Process] # , 4 J**

Minimum process value for selected input.

Identical to **[AI1 Lowest Process] # , 1 J** (*see page 477*).

**[AI4 Highest Process] # , 4 K**

Maximum process value for selected input.

Identical to **[AI1 Highest Process] # , 1 K** (*see page 477*).

**[AI5 sensor config.] , P P 5 - Menu****Access**

[Complete settings] → [Pump monitoring] → [Inlet pressure monitoring] → [AI5 sensor config.]

**About This Menu**

Following parameters can be accessed if:

- [InletPres Monitoring] , P P P is not set to [No] n o, and
- [InletPres Assign] P 5 I R is set to [AI5] A , 5.

**[AI5 Type] A , 5 E ★**

Configuration of AI5.

This parameter can be accessed if VW3A3203 I/O extension module has been inserted.

Identical to [AI4 Type] A , 4 E (see page 481).

**[AI5 min value] u , L 5 ★**

AI5 voltage scaling parameter of 0%.

Identical to [AI1 min value] u , L 1 (see page 476).

**[AI5 max value] u , H 5 ★**

AI5 voltage scaling parameter of 100%.

Identical to [AI1 max value] u , H 1 (see page 476).

**[AI5 min. value] C r L 5 ★**

AI5 current scaling parameter of 0%.

Identical to [AI1 min. value] C r L 1 (see page 476) with factory setting: [Current] D A.

**[AI5 max. value] C r H 5 ★**

AI5 current scaling parameter of 100%.

Identical to [AI1 max. value] C r H 1 (see page 476) with factory setting: [Current] D A.

**[AI5 Lowest Process] A , 5 J**

Minimum process value for selected input.

Identical to [AI1 Lowest Process] A , 1 J (see page 477).

**[AI5 Highest Process] A , 5 K**

Maximum process value for selected input.

Identical to [AI1 Highest Process] A , 1 K (see page 477).

## [AIV1 sensor config.] *P U I* - Menu

### Access

[Complete settings] → [Pump monitoring] → [Inlet pressure monitoring] → [AIV1 sensor config.]

### [AIV1 Channel Assignment] *A C I*

Channel assignment for virtual analog input AIV1.

Setting	Code / Value	Description
[Not Configured]	<i>n a</i>	Not assigned <b>Factory setting</b>
[Ref. Freq-Modbus]	<i>Π d b</i>	Reference frequency via Modbus
[Ref. Freq-CANopen]	<i>C A n</i>	Reference frequency via CANopen if a CANopen module has been inserted
[Ref. Freq-Com. Module]	<i>n E t</i>	Reference frequency via fieldbus module if a fieldbus module has been inserted
[Embedded Ethernet]	<i>E t H</i>	Embedded Ethernet

### [AIV1 Lowest Process] *A U I J*

AI virtual x: minimum process value.

Setting	Description
-32,767...32,767	Setting range <b>Factory setting: 0</b>

### [AIV1 Highest Process] *A U I K*

AI virtual x: maximum process value.

Setting	Description
-32,767...32,767	Setting range <b>Factory setting: 0</b>

**[Inlet pressure monitoring] , P P - Menu****Access**

[Complete settings] → [Pump monitoring] → [Inlet pressure monitoring]

**[InletPres High Thd] , P P H ★**

Inlet pressure monitoring high/acceptable pressure.

This parameter can be accessed if [InletPres Monitoring] , P P Π is not set to [No] n o .

Setting ( )	Description
-32,768...32,767	Setting range according to [P sensor unit] S u P r Factory setting: 0

**[InletPres Low Thd] , P P L ★**

Inlet pressure monitoring low/minimum pressure.

This parameter can be accessed if [InletPres Monitoring] , P P Π is not set to [No] n o .

Setting ( )	Description
-32,768...32,767	Setting range according to [P sensor unit] S u P r Factory setting: 0

**[InletPres Max Comp] , P P C ★**

Inlet pressure monitoring max compensation.

This parameter can be accessed if [InletPres Monitoring] , P P Π is set to [Compensation] C o Π P .

Setting ( )	Description
0...32,768	Setting range according to [P sensor unit] S u P r Factory setting: 0

**[InletPresError Resp] , P P b ★**

Pressure monitoring function response to a detected error.

This parameter can be accessed if [InletPres Monitoring] , P P Π is not set to [No] n o .

Setting	Code / Value	Description
[Ignore]	n o	Detected error ignored
[Freewheel Stop]	Y E S	Freewheel stop
[Per STT]	S T T	Stop according to [Type of stop] S T T parameter but without an error triggered after stop
[Fallback Speed]	L F F	Change to fallback speed, maintained as long as the detected error persists and the run command has not been removed <sup>(1)</sup>
[Ramp stop]	r Π P	Stop on ramp Factory setting

**1** Because, in this case, the detected error does not trigger a stop, it is recommended to assign a relay or logic output to its indication.

---

## Section 7.26

### [Pump monitoring] - [Outlet pressure monitoring]

---

#### What Is in This Section?

This section contains the following topics:

Topic	Page
[Outlet pressure monitoring] ▫ P P - Menu	487
[AI1 Sensor config.] ▫ ▫ R 1 - Menu	489
[AI2 Sensor config.] ▫ ▫ R 2 - Menu	491
[AI3 Sensor config.] ▫ ▫ R 3 - Menu	492
[AI4 Sensor config.] ▫ ▫ R 4 - Menu	493
[AI5 Sensor config.] ▫ ▫ R 5 - Menu	495
[AIV1 Sensor config.] ▫ ▫ u 1 - Menu	496
[Outlet pressure monito..] ▫ P P - Menu	497

## [Outlet pressure monitoring] ▢ PP - Menu

### Access

[Complete settings] → [Pump monitoring] → [Outlet pressure monitoring]

### About This Menu

This function detects an outlet high and low-pressure situation.

- It helps to prevent from high outlet pressure situations that can damage the hydraulic network (for example, pipe burst)
- It monitors low outlet pressure situations that can reflect damage on the hydraulic network (for example, pipe break)

This monitoring function is at the outlet station level.

The outlet pressure monitoring function requires a pressure sensor and/or a pressure switch to monitor the outlet pressure of the system.

- A high-pressure switch allows the activation of the high outlet pressure monitoring, according to the pressure switch specification.
- A pressure sensor allows the activation of both high and low outlet pressure monitoring, according to the **[OutPres Min Level] ▢ PPL** and **[OutPres Max Level] ▢ PPH** values.

Example of the station architecture:

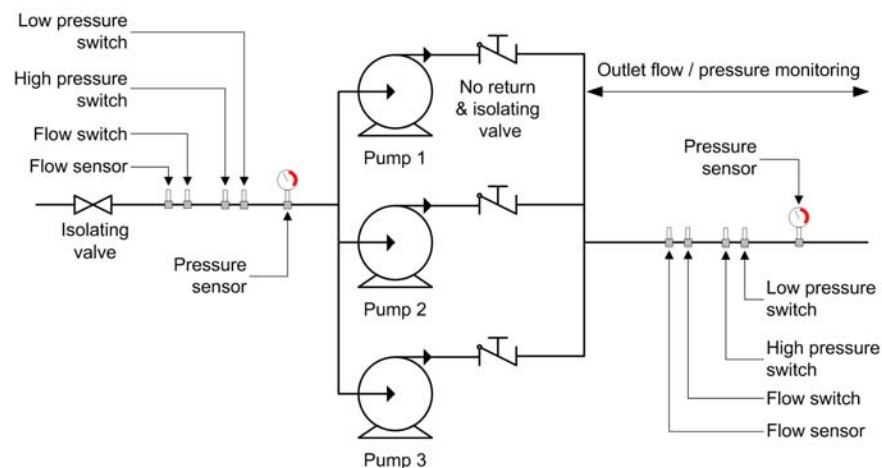

The outlet pressure monitoring function monitors the outlet pressure of the system.

- When a low-Pressure condition is present, a **[Low OutPres Warning] ▢ PLR** warning is triggered.
- When a high-Pressure condition is present, coming from the sensor, a **[High OutPres Warning] ▢ PHR** warning is triggered.
- When a high-Pressure condition is present, coming from the switch, a **[Switch OutPres Warning] ▢ PSR** warning is triggered.
- If the high-pressure condition remains for longer than **[OutPresError Delay] ▢ PPD** time, a detected **[Out Pressure High] ▢ PHF** error is triggered. The application follows the **[OutPresErrorResp] ▢ PPB** defined behavior.
- If the low-pressure condition remains for longer than **[OutPresError Delay] ▢ PPD** time, a detected **[Out Pressure Low] ▢ PLF** error is triggered. The application follows the **[OutPresError Delay] ▢ PPD** defined behavior.

#### NOTE:

- It is recommended to use a pressure switch that is open in case of high pressure and to use a digital input active at low level (DIxL). This allows stopping the pump in case of broken wire of the pressure switch.
- It is recommended to use a 4-20 mA pressure sensor and to enable the 4-20 mA loss function. This allows stopping the pump in case of broken wire of the pressure sensor.

**[OutPres Monitoring]  $\alpha P P \Pi$** 

Mode selection.

Setting	Code / Value	Description
[No]	$n o$	Inactive <b>Factory setting</b>
[Switch]	$5 W$	Activated on switch
[Sensor]	$5 n 5 r$	Activated on sensor
[Both]	$b o t h$	Activated on sensor and switch

**[OutPres DI Assign]  $\alpha P P W \star$** 

High outlet pressure switch source.

This parameter can be accessed if:

- **[OutPres Monitoring]  $\alpha P P \Pi$**  is set to **[Switch]  $5 W$** , or
- **[OutPres Monitoring]  $\alpha P P \Pi$**  is set to **[Both]  $b o t h$** .

Setting	Code / Value	Description
[Not Assigned]	$n o$	Not assigned <b>Factory setting</b>
[DI1]...[DI6]	$L , 1 \dots L , 6$	Digital input DI1...DI6
[DI11]...[DI16]	$L , 1 1 \dots L , 1 6$	Digital input DI11...DI16 if VW3A3203 I/O extension module has been inserted

**[OutletPres Assign]  $P 5 2 R \star$** 

Outlet pressure sensor assignment.

This parameter can be accessed if:

- **[OutPres Monitoring]  $\alpha P P \Pi$**  is set to **[Sensor]  $5 n 5 r$** , or
- **[OutPres Monitoring]  $\alpha P P \Pi$**  is set to **[Both]  $b o t h$** .

Setting	Code / Value	Description
[Not Configured]	$n o$	Not assigned <b>Factory setting</b>
[AI1]...[AI3]	$R , 1 \dots R , 3$	Analog input AI1...AI3
[AI4]...[AI5]	$R , 4 \dots R , 5$	Analog input AI4...AI5 if VW3A3203 I/O extension module has been inserted
[AI Virtual 1]	$R , V 1$	Virtual analogic input 1



## [AI1 Sensor config.] $\square \square R I$ - Menu

### Access

[Complete settings] → [Pump monitoring] → [Outlet pressure monito..] → [AI1 Sensor config.]

### About This Menu

Following parameters can be accessed if:

- [OutPres Monitoring]  $\square P P \Pi$  is not set to [No]  $\square \square$ , and
- [OutletPres Assign]  $P S Z R$  is set to [AI1]  $R I$ .

### [AI1 Type] $R I E$

Configuration of analog input AI1.

Setting	Code / Value	Description
[Voltage]	$I D \mu$	0-10 Vdc <b>Factory setting</b>
[Current]	$D R$	0-20 mA

### [AI1 min value] $\mu , L I \star$

AI1 voltage scaling parameter of 0%.

This parameter can be accessed if [AI1 Type]  $R I E$  is not set to [Current]  $D R$ .

Setting	Description
0.0...10.0 Vdc	Setting range <b>Factory setting:</b> 0.0 Vdc

### [AI1 max value] $\mu , H I \star$

AI1 voltage scaling parameter of 100%.

This parameter can be accessed if [AI1 Type]  $R I E$  is not set to [Current]  $D R$ .

Setting	Description
0.0...10.0 Vdc	Setting range <b>Factory setting:</b> 10.0 Vdc

### [AI1 min. value] $C r L I \star$

AI1 current scaling parameter of 0%.

This parameter can be accessed if [AI1 Type]  $R I E$  is set to [Current]  $D R$ .

Setting	Description
0.0...20.0 mA	Setting range <b>Factory setting:</b> 0.0 mA

### [AI1 max. value] $C r H I \star$

AI1 current scaling parameter of 100%.

This parameter can be accessed if [AI1 Type]  $R I E$  is set to [Current]  $D R$ .

Setting	Description
0.0...20.0 mA	Setting range <b>Factory setting:</b> 20.0 mA

**[A11 Lowest Process] R , I J**

Minimum process value for selected input.

Setting	Description
-32,767...32,767	Setting range. Value in application customer unit. <b>Factory setting:</b> 0

**[A11 Highest Process] R , I K**

Maximum process value for selected input.

Setting	Description
-32,767...32,767	Setting range. Value in application customer unit <b>Factory setting:</b> 0

**[AI2 Sensor config.] 0 0 A 2 - Menu****Access**

[Complete settings] → [Pump monitoring] → [Outlet pressure monito..] → [AI2 Sensor config.]

**[AI2 Type] A , 2 E**

Configuration of analog input AI2.

Setting	Code / Value	Description
[Voltage]	1 0 u	0-10 Vdc <b>Factory setting</b>
[Current]	0 A	0-20 mA
[PTC Management]	P E C	1 to 6 PTC (in serial)
[KTY]	K E Y	1 KTY84
[PT1000]	1 P E 3	1 PT1000 connected with 2 wires
[PT100]	1 P E 2	1 PT100 connected with 2 wires
[Water Prob]	L E u E L	Water level
[3PT1000]	3 P E 3	3 PT1000 connected with 2 wires
[3PT100]	3 P E 2	3 PT100 connected with 2 wires

**[AI2 min value] u , L 2 ★**

AI2 voltage scaling parameter of 0%.

This parameter can be accessed if [AI2 Type] A , 2 E is set to [Voltage] 1 0 u.

Identical to [AI1 min value] u , L 1 (see page 489).

**[AI2 max value] u , H 2 ★**

AI2 voltage scaling parameter of 100%.

This parameter can be accessed if [AI2 Type] A , 2 E is set to [Voltage] 1 0 u.

Identical to [AI1 max value] u , H 1 (see page 489).

**[AI2 min. value] C r L 2 ★**

AI2 current scaling parameter of 0%.

This parameter can be accessed if [AI2 Type] A , 2 E is set to [Current] 0 A.

Identical to [AI1 min. value] C r L 1 (see page 489).

**[AI2 max. value] C r H 2 ★**

AI2 current scaling parameter of 100%.

This parameter can be accessed if [AI2 Type] A , 2 E is set to [Current] 0 A.

Identical to [AI21max. value] C r H 1 (see page 489).

**[AI2 Lowest Process] A , 2 J**

Minimum process value for selected input.

Identical to [AI1 Lowest Process] A , 1 J (see page 490).

**[AI2 Highest Process] A , 2 K**

Maximum process value for selected input.

Identical to [AI1 Highest Process] A , 1 K (see page 490).

**[AI3 Sensor config.] ▢ ▢ R 3 - Menu****Access**

**[Complete settings] → [Pump monitoring] → [Outlet pressure monito..] → [AI3 Sensor config.]**

**[AI3 Type] R , 3 E**

Configuration of analog input AI3.

Identical to **[AI2 Type] R , 2 E** (see page 491) with factory setting: **[Current] ▢ R**.

**[AI3 min value] ▢ , L 3 ★**

AI3 voltage scaling parameter of 0%.

This parameter can be accessed if **[AI3 Type] R , 3 E** is set to **[Voltage] 1 ▢ ▢**.

Identical to **[AI1 min value] ▢ , L 1** (see page 489).

**[AI3 max value] ▢ , H 3 ★**

AI3 voltage scaling parameter of 100%.

This parameter can be accessed if **[AI3 Type] R , 3 E** is set to **[Voltage] 1 ▢ ▢**.

Identical to **[AI1 max value] ▢ , H 1** (see page 489).

**[AI3 min. value] C r L 3 ★**

AI3 current scaling parameter of 0%.

This parameter can be accessed if **[AI3 Type] R , 3 E** is set to **[Current] ▢ R**.

Identical to **[AI1 min. value] C r L 1** (see page 489).

**[AI3 max. value] C r H 3 ★**

AI3 current scaling parameter of 100%.

This parameter can be accessed if **[AI3 Type] R , 3 E** is set to **[Current] ▢ R**.

Identical to **[AI21 max. value] C r H 1** (see page 489).

**[AI3 Lowest Process] R , 3 J**

Minimum process value for selected input.

Identical to **[AI1 Lowest Process] R , 1 J** (see page 490).

**[AI3 Highest Process] R , 3 K**

Maximum process value for selected input.

Identical to **[AI1 Highest Process] R , 1 K** (see page 490).

**[AI4 Sensor config.] ▢ ▢ R 4 - Menu****Access**

**[Complete settings] → [Pump monitoring] → [Outlet pressure monito..] → [AI4 Sensor config.]**

**[AI4 Type] R , 4 E ★**

Configuration of analog input AI4.

This parameter can be accessed if VW3A3203 I/O extension module has been inserted.

Setting	Code / Value	Description
[Voltage]	1 0 u	0-10 Vdc
[Current]	0 R	0-20 mA
[Voltage +/-]	n 1 0 u	-10/+10 Vdc <b>Factory setting</b>
[PTC Management]	P E C	1 to 6 PTC (in serial)
[KTY]	K E Y	1 KTY84
[PT1000]	1 P E 3	1 PT1000 connected with 2 wires
[PT100]	1 P E 2	1 PT100 connected with 2 wires
[3 PT1000]	3 P E 3	3 PT1000 connected with 2 wires
[3 PT100]	3 P E 2	3 PT100 connected with 2 wires
[PT1000 in 3 wires]	1 P E 3 3	1 PT1000 connected with 3 wires (AI4 & AI5 only)
[PT100 in 3 wires]	1 P E 2 3	1 PT100 connected with 3 wires (AI4 & AI5 only)
[3 PT1000 in 3 wires]	3 P E 3 3	3 PT1000 connected with 3 wires (AI4 & AI5 only)
[3 PT100 in 3 wires]	3 P E 2 3	3 PT100 connected with 3 wires (AI4 & AI5 only)

**[AI4 min value] u , L 4 ★**

AI4 voltage scaling parameter of 0%.

This parameter can be accessed if:

- [AI4 Type] R , 4 E is set to [Voltage] 1 0 u, or
- [AI4 Type] R , 4 E is set to [Voltage +/-] n 1 0 u.

Identical to [AI1 min value] u , L 1 (see page 489).

**[AI4 max value] u , H 4 ★**

AI4 voltage scaling parameter of 100%.

This parameter can be accessed if:

- [AI4 Type] R , 4 E is set to [Voltage] 1 0 u, or
- [AI4 Type] R , 4 E is set to [Voltage +/-] n 1 0 u.

Identical to [AI1 max value] u , H 1 (see page 489).

**[AI4 min. value] C r L 4 ★**

AI4 current scaling parameter of 0%.

Identical to [AI1 min. value] C r L 1 (see page 489).

**[AI4 max. value] C r H 4 ★**

AI4 current scaling parameter of 100%.

Identical to [AI21max. value] C r H 1 (see page 489).

**[AI4 Lowest Process] R , 4 J**

Minimum process value for selected input.

Identical to [AI1 Lowest Process] R , 1 J (see page 490).

**[AI4 Highest Process] R , 4 K**

Maximum process value for selected input.

Identical to **[AI1 Highest Process] R , 1 K** (*see page 490*).

**[AI5 Sensor config.] ▢ ▢ R 5 - Menu****Access**

**[Complete settings] → [Pump monitoring] → [Outlet pressure monito..] → [AI5 Sensor config.]**

**[AI5 Type] R , 5 L ★**

Configuration of AI5.

This parameter can be accessed if VW3A3203 I/O extension module has been inserted.

Identical to **[AI4 Type] R , 4 L** (see page 493).

**[AI5 min value] ▢ , L 5 ★**

AI5 voltage scaling parameter of 0%.

This parameter can be accessed if:

- **[AI5 Type] R , 5 L** is set to **[Voltage] 1 0 ▢**, or
- **[AI5 Type] R , 5 L** is set to **[Voltage +/-] ▢ 1 0 ▢**.

Identical to **[AI1 min value] ▢ , L 1** (see page 489).

**[AI5 max value] ▢ , H 5 ★**

AI5 voltage scaling parameter of 100%.

This parameter can be accessed if:

- **[AI5 Type] R , 5 L** is set to **[Voltage] 1 0 ▢**, or
- **[AI5 Type] R , 5 L** is set to **[Voltage +/-] ▢ 1 0 ▢**.

Identical to **[AI1 max value] ▢ , H 1** (see page 489).

**[AI5 min. value] C r L 5 ★**

AI5 current scaling parameter of 0%.

Identical to **[AI1 min. value] C r L 1** (see page 489).

**[AI5 max. value] C r H 5 ★**

AI5 current scaling parameter of 100%.

Identical to **[AI21max. value] C r H 1** (see page 489).

**[AI5 Lowest Process] R , 5 J**

Minimum process value for selected input.

Identical to **[AI1 Lowest Process] R , 1 J** (see page 490).

**[AI5 Highest Process] R , 5 K**

Maximum process value for selected input.

Identical to **[AI1 Highest Process] R , 1 K** (see page 490).

## [AIV1 Sensor config.] *0 0 U I* - Menu

### Access

[Complete settings] → [Pump monitoring] → [Outlet pressure monito..] → [AIV1 Sensor config.]

### [AIV1 Channel Assignment] *A , C I*

Channel assignment for virtual analog input AIV1.

Setting	Code / Value	Description
[Not Configured]	<i>n o</i>	Not assigned <b>Factory setting</b>
[Ref. Freq-Modbus]	<i>Π d b</i>	Reference frequency via Modbus
[Ref. Freq-CANopen]	<i>C A n</i>	Reference frequency via CANopen if a CANopen module has been inserted
[Ref. Freq-Com. Module]	<i>n E t</i>	Reference frequency via fieldbus module if a fieldbus module has been inserted
[Embedded Ethernet]	<i>E t H</i>	Embedded Ethernet

### [AIV1 Lowest Process] *A U I J*

AI virtual x: minimum process value.

Setting	Description
-32,767...32,767	Setting range <b>Factory setting: 0</b>

### [AIV1 Highest Process] *A U I K*

AI virtual x: maximum process value.

Setting	Description
-32,767...32,767	Setting range <b>Factory setting: 0</b>



**[Outlet pressure monito..] ▣ P P - Menu****Access**

[Complete settings] → [Pump monitoring] → [Outlet pressure monito..]

**[OutPres Min Level] ▣ P P L ★**

Outlet pressure minimum level.

This parameter can be accessed if:

- [OutPres Monitoring] ▣ P P Π is set to [Sensor] S n S r , or
- [OutPres Monitoring] ▣ P P Π is set to [Both] b o t H .

Setting 	Description
0...32,767	Setting range, according to [P sensor unit] S u P r . <b>Factory setting:</b> 0

**[OutPres Max Level] ▣ P P H ★**

Outlet pressure maximum level.

This parameter can be accessed if:

- [OutPres Monitoring] ▣ P P Π is set to [Sensor] S n S r , or
- [OutPres Monitoring] ▣ P P Π is set to [Both] b o t H .

Setting 	Description
0...32,767	Setting range, according to [P sensor unit] S u P r . <b>Factory setting:</b> 0

**[OutPresError Delay] ▣ P P d ★**

Outlet pressure monitoring time.

This parameter can be accessed if [OutPres Monitoring] ▣ P P Π is not set to [No] n o .

Setting 	Description
0...3,600 s	Setting range <b>Factory setting:</b> 0 s

**[OutPresError Resp] ▣ P P b ★**

Outlet pressure fault config.

This parameter can be accessed if [OutPres Monitoring] ▣ P P Π is not set to [No] n o .

Setting	Code / Value	Description
[Ignore]	n o	Detected error ignored
[Freewheel Stop]	y e s	Freewheel stop
[Per STT]	s t t	Stop according to [Type of stop] S t t parameter but without an error triggered after stop
[Fallback Speed]	L F F	Change to fallback speed, maintained as long as the detected error persists and the run command has not been removed <sup>(1)</sup>
[Ramp stop]	r a m p	Stop on ramp <b>Factory setting</b>
<b>1</b> Because, in this case, the detected error does not trigger a stop, it is recommended to assign a relay or logic output to its indication.		

## Section 7.27

### [Pump monitoring] - [High flow monitoring]

#### What Is in This Section?

This section contains the following topics:

Topic	Page
[High flow monitoring] <i>HFP</i> - Menu	499
[AI1 sensor config.] <i>H , F 1</i> - Menu	501
[AI2 sensor config.] <i>HF , 2</i> - Menu	503
[AI3 sensor config.] <i>HF , 3</i> - Menu	504
[AI4 sensor config.] <i>HF , 4</i> - Menu	505
[AI5 sensor config.] <i>HF , 5</i> - Menu	506
[DI5 Pulse Sensor Config] <i>H , FB</i> - Menu	507
[DI6 Pulse Sensor Config] <i>H , F 9</i> - Menu	508
[AIV1 Sensor config.] <i>o o u 1</i> - Menu	509
[High flow monitoring] <i>HFP</i> - Menu	510

## [High flow monitoring] *HFP* - Menu

### Access

[Complete settings] → [Pump monitoring] → [High flow monitoring]

### About This Menu

The high flow monitoring helps to detect abnormal outlet high flow situation:

- Works outside application flow capabilities
- Helps to detect pipe burst

This monitoring function is at outlet station level. This function requires a flow sensor to monitor the outlet flow of the system.

This is an example of a station architecture:

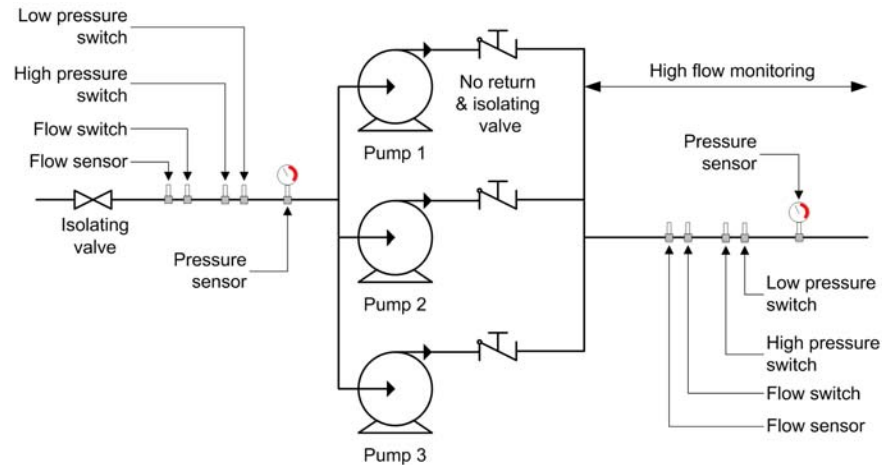

High flow monitoring function monitors the outlet flow of the system:

- When the outlet flow feedback is higher than **[HighFlow MaxLevel] *HFP L***, a warning **[High Flow Warning] *HFP R*** is triggered. The application does not stop.
- If the outlet flow feedback remains higher than **[HighFlow MaxLevel] *HFP L*** for longer than **[HighFlowError Delay] *HFP d*** time, a detected error **[High Flow Error] *HFP F*** is triggered. The application follows the **[HighFlowErrorResp] *HFP b*** defined behavior.

If a high flow situation is detected in a multi-pump system, all the pumps stop.

### [HighFlow Activation] *HFP n*

Mode selection.

Setting	Code / Value	Description
[No]	<i>n 0</i>	Function disabled <b>Factory setting</b>
[YES]	<i>Y E 5</i>	Function enabled

**[Inst. Flow Assign.] F 5 I R** ★

Installation flow sensor assignment.

This parameter can be accessed if **[HighFlow Activation] H F P Π** is not set to **[No] n o**.

Setting	Code / Value	Description
<b>[Not Configured]</b>	<b>n o</b>	Not assigned <b>Factory setting</b>
<b>[AI1]...[AI3]</b>	<b>R , 1...R , 3</b>	Analog input AI1...AI3
<b>[AI4]...[AI5]</b>	<b>R , 4...R , 5</b>	Analog input AI4...AI5 if VW3A3203 I/O extension module has been inserted
<b>[AI Virtual 1]</b>	<b>R , V 1</b>	Virtual analogic input 1
<b>[PulseInput Assignment On DI5]...[PulseInput Assignment On DI6]</b>	<b>P , 5...P , 6</b>	Digital input DI5...DI6 used as pulse input
<b>[Flow Estimation]</b>	<b>S L P F</b>	Sensor less estimated flow

## [AI1 sensor config.] H , F I - Menu

### Access

[Complete settings] → [Pump monitoring] → [High flow monitoring] → [AI1 sensor config.]

### About This Menu

Following parameters can be accessed if:

- [Flow limitation Mode] FLM is not set to [No] n o, and
- [Inst. Flow Assign.] F S I R is set to [AI1] R , I .

### [AI1 Type] R , I E

Configuration of analog input AI1.

Setting	Code / Value	Description
[Voltage]	I D u	0-10 Vdc <b>Factory setting</b>
[Current]	D R	0-20 mA

### [AI1 min value] u , L I ★

AI1 voltage scaling parameter of 0%.

This parameter can be accessed if [AI1 Type] R , I E is set to [Voltage] I D u .

Setting	Description
0.0...10.0 V	Setting range <b>Factory setting:</b> 0.0 V

### [AI1 max value] u , H I ★

AI1 voltage scaling parameter of 100%.

This parameter can be accessed if [AI1 Type] R , I E is set to [Voltage] I D u .

Setting	Description
0.0...10.0 V	Setting range <b>Factory setting:</b> 10.0 V

### [AI1 min. value] C r L I ★

AI1 current scaling parameter of 0%.

This parameter can be accessed if [AI1 Type] R , I E is set to [Current] D R .

Setting	Description
0.0...20.0 mA	Setting range <b>Factory setting:</b> 0.0 mA

### [AI1 max. value] C r H I ★

AI1 current scaling parameter of 100%.

This parameter can be accessed if [AI1 Type] R , I E is set to [Current] D R .

Setting	Description
0.0...20.0 mA	Setting range <b>Factory setting:</b> 20.0 mA

**[A11 Lowest Process]R , I J**

Minimum process value for selected input.

Setting	Description
-32,768...32,767	Setting range. Value in application customer unit. <b>Factory setting:</b> 0

**[A11 Highest Process]R , I K**

Maximum process value for selected input.

Setting	Description
-32,768...32,767	Setting range. Value in application customer unit. <b>Factory setting:</b> 0

**[AI2 sensor config.] HF , 2 - Menu****Access**

[Complete settings] → [Pump monitoring] → [High flow monitoring] → [AI2 sensor config.]

**[AI2 Type] H , 2 E**

Configuration of analog input AI2.

Setting	Code / Value	Description
[Voltage]	1 0 U	0-10 Vdc Factory setting
[Current]	0 A	0-20 mA
[PTC Management]	P E C	1 to 6 PTC (in serial)
[KTY]	K E Y	1 KTY84
[PT1000]	1 P E 3	1 PT1000 connected with 2 wires
[PT100]	1 P E 2	1 PT100 connected with 2 wires
[Water Prob]	L E U E L	Water level
[3PT1000]	3 P E 3	3 PT1000 connected with 2 wires
[3PT100]	3 P E 2	3 PT100 connected with 2 wires

**[AI2 min value] U , L 2 ★**

AI2 voltage scaling parameter of 0%.

This parameter can be accessed if [AI2 Type] H , 2 E is set to [Voltage] 1 0 U.

Identical to [AI1 min value] U , L 1 (see page 501).

**[AI2 max value] U , H 2 ★**

AI2 voltage scaling parameter of 100%.

This parameter can be accessed if [AI2 Type] H , 2 E is set to [Voltage] 1 0 U.

Identical to [AI1 max value] U , H 1 (see page 501).

**[AI2 min. value] C r L 2 ★**

AI2 current scaling parameter of 0%.

This parameter can be accessed if [AI2 Type] H , 2 E is set to [Current] 0 A.

Identical to [AI1 min. value] C r L 1 (see page 501).

**[AI2 max. value] C r H 2 ★**

AI2 current scaling parameter of 100%.

This parameter can be accessed if [AI2 Type] H , 2 E is set to [Current] 0 A.

Identical to [AI1 max. value] C r H 1 (see page 501).

**[AI2 Lowest Process] H , 2 J**

Minimum process value for selected input.

Identical to [AI1 Lowest Process] H , 1 J (see page 502).

**[AI2 Highest Process] H , 2 K**

Maximum process value for selected input.

Identical to [AI1 Highest Process] H , 1 K (see page 502).

## [AI3 sensor config.] HF , 3 - Menu

### Access

[Complete settings] → [Pump monitoring] → [High flow monitoring] → [AI3 sensor config.]

### [AI3 Type] R , 3 E

Configuration of analog input AI3 type.

Identical to [AI2 Type] R , 2 E (see page 503) with factory setting: [Current] 0 R.

### [AI3 min value] U , L 3 ★

AI3 voltage scaling parameter of 0%.

This parameter can be accessed if [AI3 Type] R , 3 E is set to [Voltage] 1 0 U.

Identical to [AI1 min value] U , L 1 (see page 501).

### [AI3 max value] U , H 3 ★

AI3 voltage scaling parameter of 100%.

This parameter can be accessed if [AI3 Type] R , 3 E is set to [Voltage] 1 0 U.

Identical to [AI1 max value] U , H 1 (see page 501).

### [AI3 min. value] C r L 3 ★

AI3 current scaling parameter of 0%.

This parameter can be accessed if [AI3 Type] R , 3 E is set to [Current] 0 R.

Identical to [AI1 min. value] C r L 1 (see page 501).

### [AI3 max. value] C r H 3 ★

AI3 current scaling parameter of 100%.

This parameter can be accessed if [AI3 Type] R , 3 E is set to [Current] 0 R.

Identical to [AI1 max. value] C r H 1 (see page 501).

### [AI3 Lowest Process] R , 3 J

Minimum process value for selected input.

Identical to [AI1 Lowest Process] R , 1 J (see page 502).

### [AI3 Highest Process] R , 3 K

Maximum process value for selected input.

Identical to [AI1 Highest Process] R , 1 K (see page 502).



**[AI4 sensor config.] HF , 4 - Menu****Access**

[Complete settings] → [Pump monitoring] → [High flow monitoring] → [AI4 sensor config.]

**[AI4 Type] R , 4 L ★**

Configuration of analog input AI4.

This parameter can be accessed if VW3A3203 relay output option module has been inserted.

Setting	Code / Value	Description
[Voltage]	1 0 0	0-10 Vdc
[Current]	0 0	0-20 mA
[Voltage +/-]	n 1 0 0	-10/+10 Vdc <b>Factory setting</b>
[PTC Management]	P 0 0	1 to 6 PTC (in serial)
[KTY]	K 0 0	1 KTY84
[PT1000]	1 P 0 0	1 PT1000 connected with 2 wires
[PT100]	1 P 0 1	1 PT100 connected with 2 wires
[3 PT1000]	3 P 0 0	3 PT1000 connected with 2 wires
[3 PT100]	3 P 0 1	3 PT100 connected with 2 wires
[PT1000 in 3 wires]	1 P 0 0 0	1 PT1000 connected with 3 wires (AI4 & AI5 only)
[PT100 in 3 wires]	1 P 0 1 0	1 PT100 connected with 3 wires (AI4 & AI5 only)
[3 PT1000 in 3 wires]	3 P 0 0 0	3 PT1000 connected with 3 wires (AI4 & AI5 only)
[3 PT100 in 3 wires]	3 P 0 1 0	3 PT100 connected with 3 wires (AI4 & AI5 only)

**[AI4 min value] 0 , L 4 ★**

AI4 voltage scaling parameter of 0%.

Identical to [AI1 min value] 0 , L 1 (see page 501).

**[AI4 max value] 0 , H 4 ★**

AI4 voltage scaling parameter of 100%.

Identical to [AI1 max value] 0 , H 1 (see page 501).

**[AI4 min. value] 0 , L 4 ★**

AI4 current scaling parameter of 0%.

Identical to [AI1 min. value] 0 , L 1 (see page 501).

**[AI4 max. value] 0 , H 4 ★**

AI4 current scaling parameter of 100%.

Identical to [AI1 max. value] 0 , H 1 (see page 501).

**[AI4 Lowest Process] R , 4 J**

Minimum process value for selected input.

Identical to [AI1 Lowest Process] R , 1 J (see page 502).

**[AI4 Highest Process] R , 4 K**

Maximum process value for selected input.

Identical to [AI1 Highest Process] R , 1 K (see page 502).

## [AI5 sensor config.] HF , 5 - Menu

### Access

[Complete settings] → [Pump monitoring] → [High flow monitoring] → [AI5 sensor config.]

### [AI5 Type] R , 5 L ★

Configuration of analog input AI5.

This parameter can be accessed if VW3A3203 I/O extension module has been inserted.

Identical to [AI4 Type] R , 4 L (see page 505).

### [AI5 min value] U , L 5 ★

AI5 voltage scaling parameter of 0%.

Identical to [AI1 min value] U , L 1 (see page 501).

### [AI5 max value] U , H 5 ★

AI5 voltage scaling parameter of 100%.

Identical to [AI1 max value] U , H 1 (see page 501).

### [AI5 min. value] C r L 5 ★

AI5 current scaling parameter of 0%.

Identical to [AI1 min. value] C r L 1 (see page 501).

### [AI5 max. value] C r H 5 ★

AI5 current scaling parameter of 100%.

Identical to [AI1 max. value] C r H 1 (see page 501).

### [AI5 Lowest Process] R , 5 J

Minimum process value for selected input.

Identical to [AI1 Lowest Process] R , 1 J (see page 502).

### [AI5 Highest Process] R , 5 K

Maximum process value for selected input.

Identical to [AI1 Highest Process] R , 1 K (see page 502).

**[DI5 Pulse Sensor Config] H , F B - Menu****Access**

[Complete settings] → [Pump monitoring] → [High flow monitoring] → [DI5 Pulse Sensor Config]

**[DI5 PulseInput Low Freq] P , L 5**

Minimum pulse input.

Pulse input DI5: frequency for 0% of the equivalent analog signal.

Setting	Description
0.00...30,000.00 Hz	Setting range <b>Factory setting:</b> 0 Hz

**[DI5 PulseInput High Freq] P , H 5**

Maximum pulse input.

Pulse input DI5: frequency for 100% of the equivalent analog signal.

Setting	Description
0.00...30.00 kHz	Setting range <b>Factory setting:</b> 30.00 kHz

**[DI5 Min Process] P , 5 J**

Minimum process value for selected input.

Setting	Description
-32,768...32,767	Setting range <b>Factory setting:</b> 0

**[DI5 Max Process] P , 5 K**

Maximum process value for selected input.

Setting	Description
-32,768...32,767	Setting range <b>Factory setting:</b> 0

**[DI6 Pulse Sensor Config] H , F 9 - Menu****Access**

[Complete settings] → [Pump monitoring] → [High flow monitoring] → [DI6 Pulse Sensor Config]

**[DI6 PulseInput Low Freq] P , L 5**

Minimum pulse input.

Pulse input DI5: frequency for 0% of the equivalent analog signal.

Setting	Description
0.00...30,000.00 Hz	Setting range <b>Factory setting:</b> 0 Hz

**[DI6 PulseInput High Freq] P , H 5**

Maximum pulse input.

Pulse input DI5: frequency for 100% of the equivalent analog signal.

Setting	Description
0.00...30.00 kHz	Setting range <b>Factory setting:</b> 30.00 kHz

**[DI6 Min Process] P , 5 J**

Minimum process value for selected input.

Setting	Description
-32,768...32,767	Setting range <b>Factory setting:</b> 0

**[DI6 Max Process] P , 5 K**

Maximum process value for selected input.

Setting	Description
-32,768...32,767	Setting range <b>Factory setting:</b> 0

**[AIV1 Sensor config.]**  **- Menu****Access**

[Complete settings] → [Pump monitoring] → [High flow monitoring] → [AIV1 Sensor config.]

**[AIV1 Channel Assignment]**  **-**

Channel assignment for virtual analog input AIV1.

Setting	Code / Value	Description
[Not Configured]	<i>n o</i>	Not assigned <b>Factory setting</b>
[Ref. Freq-Modbus]	<i>Π d b</i>	Reference frequency via Modbus
[Ref. Freq-CANopen]	<i>ϸ A n</i>	Reference frequency via CANopen if a CANopen module has been inserted
[Ref. Freq-Com. Module]	<i>n E t</i>	Reference frequency via fieldbus module if a fieldbus module has been inserted
[Embedded Ethernet]	<i>E t H</i>	Embedded Ethernet

**[AIV1 Lowest Process]**  **-**

Aiv1 lowest process.

Setting	Description
-32,767...32,767	Setting range <b>Factory setting:</b> 0

**[AIV1 Highest Process]**  **-**

Aiv1 highest process.

Setting	Description
-32,767...32,767	Setting range <b>Factory setting:</b> 0

**[High flow monitoring] HFP - Menu****Access**

[Complete settings] → [Pump monitoring] → [High flow monitoring]

**About This Menu**

Following parameters can be accessed if [HighFlow Activation] HFP is not set to [No] n o.

**[HighFlow MaxLevel] HFPL ★**

High flow max level.

Setting ( )	Description
0...32,767	Setting range, according to [Flow rate unit] S u F r <b>Factory setting:</b> 32767

**[HighFlowError Delay] HFPD ★**

High flow delay.

Setting ( )	Description
0...3,600 s	Setting range <b>Factory setting:</b> 10 s

**[HighFlowError Resp] HFPE ★**

High flow monitoring function response to a detected error.

Setting	Code / Value	Description
[Ignore]	n o	Detected error ignored
[Freewheel Stop]	Y E S	Freewheel stop
[Per STT]	S E E	Stop according to [Type of stop] S E E parameter but without an error triggered after stop
[Fallback Speed]	L F F	Change to fallback speed, maintained as long as the detected error persists and the run command has not been removed <sup>(1)</sup>
[Ramp stop]	r P P	Stop on ramp <b>Factory setting</b>
<b>1</b> Because, in this case, the detected error does not trigger a stop, it is recommended to assign a relay or logic output to its indication.		

---

## Section 7.28

### [Fan] - [PID controller]

---

#### What Is in This Section?

This section contains the following topics:

Topic	Page
[PID controller] $P, d$ - Overview	512
[Feedback] $F, d, b$ - Menu	515
[Reference frequency] $r, F$ - Menu	521
[PID preset references] $P, r, i$ - Menu	524
[Reference frequency] $r, F$ - Menu	526
[Settings] $S, t$ - Menu	527

## [PID controller] P , d - Overview

### About This Menu

**NOTE:** This function cannot be used with some other functions. Follow the instructions about the compatibility of functions.

### Block Diagram

The function is activated by assigning an analog input to the PID feedback (measurement).

The PID feedback needs to be assigned to one of the analog inputs AI1 to AI5 or a pulse input, according to whether any I/O extension module has been inserted.

The PID reference needs to be assigned to the following parameters:

- Preset references via digital inputs ([Ref PID Preset 2] r P 2, [Ref PID Preset 3] r P 3, [Ref PID Preset 4] r P 4).
- In accordance with the configuration of [Intern PID Ref] P , i :
  - [Internal PID ref] r P i, or
  - Reference A [Ref Freq 1 Config] F r 1 or [Ref.1B channel] F r 1 b.

### Combination Table for Preset PID References:

DI (P r 4)	DI (P r 2)	P r 2 = n o	Reference
			r P i or F r 1 ( b )
0	0		r P i or F r 1 ( b )
0	1		r P 2
1	0		r P 3
1	1		r P 4

A predictive speed reference can be used to initialize the speed on restarting the process.

Scaling of feedback and references:

- [Min PID feedback] P , F 1, [Max PID feedback] P , F 2 parameters can be used to scale the PID feedback (sensor range). **This scale MUST be maintained for all other parameters.**
- [Min PID Process] P , P 1, [Max PID Process] P , P 2 parameters can be used to scale the adjustment range, for example the reference. **Check that the adjustment range remains within the sensor range.**

The maximum value of the scaling parameters is 32,767. To facilitate the installation, it is recommended to use values as close as possible to this maximum level, while retaining powers of 10 in relation to the actual values. The scaling is without unit if [Type of control] E o C E is set to [NA] n A, in % if set to [OTHER] o E H E r, in process unit if set to [PRESSURE] P r E 5 5 or [FLOW] F L o W.

### Example

Adjustment of the volume in a tank, 6...15 m<sup>3</sup>.

- Probe used 4-20 mA, 4.5 m<sup>3</sup> for 4 mA and 20 m<sup>3</sup> for 20 mA, with the result that P , F 1 = 4,500 and P , F 2 = 20,000.
- Adjustment range 6 to 15 m<sup>3</sup>, with the result that P , P 1 = 6,000 (min. reference) and P , P 2 = 15,000 (max. reference).
- Example references:
  - r P 1 (internal reference) = 9,500
  - r P 2 (preset reference) = 6,500
  - r P 3 (preset reference) = 8,000
  - r P 4 (preset reference) = 11,200



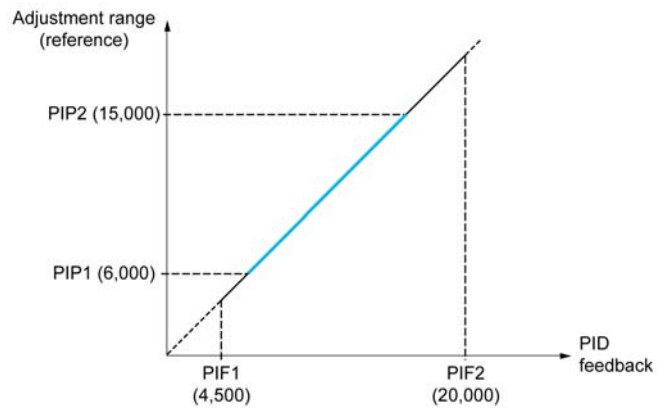

Other parameters:

- Reversal of the direction of correction **[PID Inversion] P, L**. If **[PID Inversion] P, L** is set to **[No]**, the speed of the motor increases when the detected error is positive (for example pressure control with a compressor). If **[PID Inversion] P, L** is set to **[Yes]**, the speed of the motor decreases when the detected error is positive (for example temperature control using a cooling fan).
- The integral gain may be short-circuited by a digital input.
- A warning on the **[PID feedback]** may be configured.
- A warning on the **[PID error]** may be configured.

### "Manual - Automatic" Operation with PID

This function combines the PID controller, the preset speeds, and a manual reference. Depending on the state of the digital input, the speed reference is given by the preset speeds or by a manual reference input via the PID function.

Manual PID reference **[Manual PID reference] P, M**:

- Analog inputs AI1 to AI5
- Pulse inputs

Predictive speed reference **[Predictive Speed Ref] F P**:

- **[AI1] A, 1**: analog input
- **[AI2] A, 2**: analog input
- **[AI3] A, 3**: analog input
- **[AI4] A, 4**: analog input
- **[AI5] A, 5**: analog input
- **[DI5 PulseInput Assignment] P, 5**: pulse input
- **[DI6 PulseInput Assignment] P, 6**: pulse input
- **[Ref.Freq-Rmt.Term] L C C**: Graphic Display Terminal
- **[Modbus] M d b**: integrated Modbus
- **[CANopen] C A n**: CANopen®
- **[Com. Module] n E E**: fieldbus option module (if inserted)
- **[Embedded Ethernet] E E H**: integrated Ethernet Modbus TCP

**Setting Up the PID controller**

**1. Configuration in PID mode.**

Refer to the Block Diagram (see page 512).

**2. Perform a test in factory settings mode.**

To optimize the drive, adjust [PID Prop.Gain]  $rPG$  or [PID Intgl.Gain]  $rIG$  gradually and independently, and observe the effect on the PID feedback in relation to the reference.

**3. If the factory settings are unstable or the reference is incorrect.**

Step	Action
1	Perform a test with a speed reference in Manual mode (without PID controller) and with the drive on load for the speed range of the system: <ul style="list-style-type: none"> <li>• In steady state, the speed must be stable and comply with the reference, and the PID feedback signal must be stable.</li> <li>• In transient state, the speed must follow the ramp and stabilize quickly, and the PID feedback must follow the speed. If not, see the settings for the drive and/or sensor signal and wiring.</li> </ul>
2	Switch to PID mode.
3	Set [PID ramp] $rPP$ to the minimum permitted by the mechanism without triggering an [DC Bus Overvoltage] $o b F$ .
4	Set the integral gain [PID Intgl.Gain] $rIG$ to minimum.
5	Leave the derivative gain [PID derivative gain] $rdG$ at 0.
6	Observe the PID feedback and the reference.
7	Switch the drive ON/OFF a number of times or vary the load or reference rapidly a number of times.
8	Set the proportional gain [PID Prop.Gain] $rPG$ in order to ascertain the compromise between response time and stability in transient phases (slight overshoot and 1 to 2 oscillations before stabilizing).
9	If the reference varies from the preset value in steady state, gradually increase the integral gain [PID Intgl.Gain] $rIG$ , reduce the proportional gain [PID Prop.Gain] $rPG$ in the event of instability (pump applications), find a compromise between response time and static precision (see diagram).
10	Lastly, the derivative gain may permit the overshoot to be reduced and the response time to be improved, although this is more difficult to obtain a compromise in terms of stability, as it depends on 3 gains.
11	Perform in-production tests over the whole reference range.

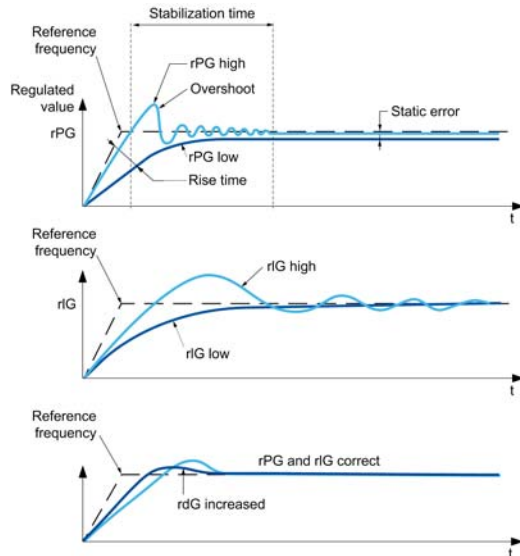

The oscillation frequency depends on the system kinematics:

Parameter	Rise time	Overshoot	Stabilization time	Static Error
rPG +	- -	+	=	-
rIG +	-	++	+	- -
rdG +	=	-	-	=

## [Feedback] *F d b* - Menu

### Access

[Complete settings] → [Fan] → [PID controller] → [Feedback]

### About This Menu

**NOTE:** This function cannot be used with some other functions. Follow the instructions about the compatibility of functions.

### [Type of Control] *ℓ ◻ ℓ ℓ*

Type of control for the PID = unit choice.

Setting	Code / Value	Description
[nA]	<i>n R</i>	(without unit) <b>Factory setting</b>
[Pressure]	<i>P</i>	Pressure control and unit
[Flow]	<i>F</i>	Flow control and unit
[Other]	<i>◻</i>	Other control and unit (%)

### [PID Feedback] *P , F*

PID controller feedback.

Setting	Code / Value	Description
[No]	<i>n ◻</i>	Not assigned <b>Factory setting</b>
[AI1]...[AI3]	<i>R , 1... R , 3</i>	Analog input AI1...AI3
[AI4]...[AI5]	<i>R , 4... R , 5</i>	Analog input AI4...AI5 if VW3A3203 I/O extension module has been inserted
[AI Virtual 1]	<i>R , ◻ 1</i>	Virtual analogic input 1
[PulseInput Assignment On DI5]...[PulseInput Assignment On DI6]	<i>P , 5... P , 6</i>	Digital input DI5...DI6 used as pulse input

### [AI1 Type] *R , 1 ℓ ★*

Configuration of analog input AI1.

This parameter can be accessed if [PID Feedback] *P , F* is set to [AI1] *R , 1*.

Setting	Code / Value	Description
[Voltage]	<i>1 0 ◻</i>	0-10 Vdc <b>Factory setting</b>
[Current]	<i>0 R</i>	0-20 mA

### [AI1 min value] *◻ , L 1 ★*

AI1 voltage scaling parameter of 0%.

This parameter can be accessed if:

- [PID Feedback] *P , F* is set to [AI1] *R , 1*, and
- [AI1 Type] *R , 1 ℓ* is not set to [Voltage] *1 0 ◻*.

Setting	Description
0.0...10.0 Vdc	Setting range <b>Factory setting:</b> 0.0 Vdc

**[AI1 max value]  $\cup, H, I$  ★**

AI1 voltage scaling parameter of 100%.

This parameter can be accessed if:

- **[PID Feedback]  $P, F$**  is set to **[AI1]  $R, I$** , and
- **[AI1 Type]  $R, I, E$**  is not set to **[Voltage]  $ID \cup$** .

Setting	Description
0.0...10.0 Vdc	Setting range <b>Factory setting:</b> 10.0 Vdc

**[AI1 min. value]  $C, R, L, I$  ★**

AI1 current scaling parameter of 0%.

This parameter can be accessed if:

- **[PID Feedback]  $P, F$**  is set to **[AI1]  $R, I$** , and
- **[AI1 Type]  $R, I, E$**  is not set to **[Current]  $\emptyset R$** .

Setting	Description
0.0...20.0 mA	Setting range <b>Factory setting:</b> 0.0 mA

**[AI1 max. value]  $C, R, H, I$  ★**

AI1 current scaling parameter of 100%.

This parameter can be accessed if:

- **[PID Feedback]  $P, F$**  is set to **[AI1]  $R, I$** , and
- **[AI1 Type]  $R, I, E$**  is not set to **[Current]  $\emptyset R$** .

Setting	Description
0.0...20.0 mA	Setting range <b>Factory setting:</b> 20.0 mA

**[AI2 Type]  $R, I, \emptyset E$  ★**

Configuration of analog input AI2.

This parameter can be accessed if **[PID Feedback]  $P, F$**  is set to **[AI2]  $R, I, \emptyset$** .

Setting	Code / Value	Description
<b>[Voltage]</b>	$ID \cup$	0-10 Vdc <b>Factory setting</b>
<b>[Current]</b>	$\emptyset R$	0-20 mA
<b>[PTC Management]</b>	$P E C$	1 to 6 PTC (in serial)
<b>[KTY]</b>	$K E Y$	1 KTY84
<b>[PT1000]</b>	$I P E \exists$	1 PT1000 connected with 2 wires
<b>[PT100]</b>	$I P E \emptyset$	1 PT100 connected with 2 wires
<b>[Water Prob]</b>	$L E \cup E L$	Water level
<b>[3PT1000]</b>	$\exists P E \exists$	3 PT1000 connected with 2 wires
<b>[3PT100]</b>	$\exists P E \emptyset$	3 PT100 connected with 2 wires

**[AI2 min value]  $\cup, L, \emptyset$  ★**

AI2 voltage scaling parameter of 0%.

This parameter can be accessed if:

- **[PID Feedback]  $P, F$**  is set to **[AI2]  $R, I, \emptyset$** , and
- **[AI2 Type]  $R, I, \emptyset E$**  is not set to **[Voltage]  $ID \cup$** .

Identical to **[AI1 min value]  $\cup, L, I$** . (see page 515)

**[AI2 max value]  $\mu, H 2$  ★**

AI2 voltage scaling parameter of 100%.

This parameter can be accessed if:

- **[PID Feedback]  $P, F$**  is set to **[AI2]  $R, 2$** , and
- **[AI2 Type]  $R, 2 E$**  is not set to **[Voltage]  $1 D \mu$** .

Identical to **[AI1 max value]  $\mu, H 1$** . (see page 516)

**[AI2 min. value]  $C, r, L 2$  ★**

AI2 current scaling parameter of 0%.

This parameter can be accessed if:

- **[PID Feedback]  $P, F$**  is set to **[AI2]  $R, 2$** , and
- **[AI2 Type]  $R, 2 E$**  is not set to **[Current]  $0 R$** .

Identical to **[AI1 min. value]  $C, r, L 1$**  (see page 516).

**[AI2 max. value]  $C, r, H 2$  ★**

AI2 current scaling parameter of 100%.

This parameter can be accessed if:

- **[PID Feedback]  $P, F$**  is set to **[AI2]  $R, 2$** , and
- **[AI2 Type]  $R, 2 E$**  is not set to **[Current]  $0 R$** .

Identical to **[AI1 max. value]  $C, r, H 1$**  (see page 516).

**[AI3 Type]  $R, 3 E$  ★**

Configuration of analog input AI3.

This parameter can be accessed if **[PID Feedback]  $P, F$**  is set to **[AI3]  $R, 3$** .

Identical to **[AI2 Type]  $R, 2 E$**  with factory setting: **[Current]  $0 R$**  (see page 516) with factory setting: **[Current]  $0 R$** .

**[AI3 min value]  $\mu, L 3$  ★**

AI3 voltage scaling parameter of 0%.

This parameter can be accessed if:

- **[PID Feedback]  $P, F$**  is set to **[AI3]  $R, 3$** , and
- **[AI3 Type]  $R, 3 E$**  is not set to **[Voltage]  $1 D \mu$** .

Identical to **[AI1 min value]  $\mu, L 1$** . (see page 515)

**[AI3 max value]  $\mu, H 3$  ★**

AI3 voltage scaling parameter of 100%.

This parameter can be accessed if:

- **[PID Feedback]  $P, F$**  is set to **[AI3]  $R, 3$** , and
- **[AI3 Type]  $R, 3 E$**  is not set to **[Voltage]  $1 D \mu$** .

Identical to **[AI1 max value]  $\mu, H 1$** . (see page 516)

**[AI3 min. value]  $C, r, L 3$  ★**

AI3 current scaling parameter of 0%.

This parameter can be accessed if:

- **[PID Feedback]  $P, F$**  is set to **[AI3]  $R, 3$** , and
- **[AI3 Type]  $R, 3 E$**  is not set to **[Current]  $0 R$** .

Identical to **[AI1 min. value]  $C, r, L 1$**  (see page 516).

**[AI3 max. value] C r H 3 ★**

AI3 current scaling parameter of 100%.

This parameter can be accessed if:

- **[PID Feedback] P , F** is set to **[AI3] R , 3**, and
- **[AI3 Type] R , 3 E** is not set to **[Current] 0 R**.

Identical to **[AI1 max. value] C r H 1** (see page 516).

**[AI4 Type] R , 4 E ★**

Configuration of analog input AI4.

This parameter can be accessed if:

- VW3A3203 I/O extension module has been inserted, and
- **[PID Feedback] P , F** is set to **[AI4] AI4**.

Setting	Code / Value	Description
<b>[Voltage]</b>	<b>1 0 0</b>	0-10 Vdc
<b>[Current]</b>	<b>0 R</b>	0-20 mA
<b>[Voltage +/-]</b>	<b>n 1 0 0</b>	-10/+10 Vdc <b>Factory setting</b>
<b>[PTC Management]</b>	<b>P E C</b>	1 to 6 PTC (in serial)
<b>[KTY]</b>	<b>K E Y</b>	1 KTY84
<b>[PT1000]</b>	<b>1 P E 3</b>	1 PT1000 connected with 2 wires
<b>[PT100]</b>	<b>1 P E 2</b>	1 PT100 connected with 2 wires
<b>[3 PT1000]</b>	<b>3 P E 3</b>	3 PT1000 connected with 2 wires
<b>[3 PT100]</b>	<b>3 P E 2</b>	3 PT100 connected with 2 wires
<b>[PT1000 in 3 wires]</b>	<b>1 P E 3 3</b>	1 PT1000 connected with 3 wires (AI4 & AI5 only)
<b>[PT100 in 3 wires]</b>	<b>1 P E 2 3</b>	1 PT100 connected with 3 wires (AI4 & AI5 only)
<b>[3 PT1000 in 3 wires]</b>	<b>3 P E 3 3</b>	3 PT1000 connected with 3 wires (AI4 & AI5 only)
<b>[3 PT100 in 3 wires]</b>	<b>3 P E 2 3</b>	3 PT100 connected with 3 wires (AI4 & AI5 only)

**[AI4 min value] 0 , L 4 ★**

AI4 voltage scaling parameter of 0%.

This parameter can be accessed if:

- **[PID Feedback] P , F** is set to **[AI4] R , 4**, and
- **[AI4 Type] R , 4 E** is not set to **[Voltage] 1 0 0**.

Identical to **[AI1 min value] 0 , L 1**. (see page 515)

**[AI4 max value] 0 , H 4 ★**

AI4 voltage scaling parameter of 100%.

This parameter can be accessed if:

- **[PID Feedback] P , F** is set to **[AI4] R , 4**, and
- **[AI4 Type] R , 4 E** is not set to **[Voltage] 1 0 0**.

Identical to **[AI1 max value] 0 , H 1**. (see page 516)

**[AI4 min. value] C r L 4 ★**

AI4 current scaling parameter of 0%.

This parameter can be accessed if:

- **[PID Feedback] P , F** is set to **[AI4] R , 4**, and
- **[AI4 Type] R , 4 E** is not set to **[Current] 0 R**.

Identical to **[AI1 min. value] C r L 1** (see page 516).

**[AI4 max. value] C r H 4 ★**

AI4 current scaling parameter of 100%.

This parameter can be accessed if:

- **[PID Feedback] P , F** is set to **[AI4] R , 4**, and
- **[AI4 Type] R , 4 E** is not set to **[Current] o R**.

Identical to **[AI1 max. value] C r H 1** (see page 516).

**[AI5 Type] R , 5 E ★**

Configuration of analog input AI5.

This parameter can be accessed if:

- VW3A3203 I/O extension module has been inserted, and
- **[PID Feedback] P , F** is set to **[AI5] R , 5**.

Identical to **[AI4 Type] R , 4 E**.

**[AI5 min value] u , L 5 ★**

AI5 voltage scaling parameter of 0%.

This parameter can be accessed if:

- **[PID Feedback] P , F** is set to **[AI5] R , 5**, and
- **[AI5 Type] R , 5 E** is set to **[Voltage] I D u**.

Identical to **[AI1 min value] u , L 1** (see page 515)

**[AI5 max value] u , H 5 ★**

AI5 voltage scaling parameter of 100%.

This parameter can be accessed if:

- **[PID Feedback] P , F** is set to **[AI5] R , 5**, and
- **[AI5 Type] R , 5 E** is not set to **[Voltage] I D u**.

Identical to **[AI1 max value] u , H 1** (see page 516)

**[AI5 min. value] C r L 5 ★**

AI5 current scaling parameter of 0%.

This parameter can be accessed if:

- **[PID Feedback] P , F** is set to **[AI5] R , 5**, and
- **[AI5 Type] R , 5 E** is not set to **[Current] o R**.

Identical to **[AI1 min. value] C r L 1** (see page 516).

**[AI5 max. value] C r H 5 ★**

AI5 current scaling parameter of 100%.

This parameter can be accessed if:

- **[PID Feedback] P , F** is set to **[AI5] R , 5**, and
- **[AI5 Type] R , 5 E** is not set to **[Current] o R**.

Identical to **[AI1 max. value] C r H 1** (see page 516).

**[Min PID feedback] P , F 1 ★**

Minimum PID feedback.

This parameter can be accessed if **[PID Feedback] P , F** is not set to **[Not Configured] n o**.

Setting ( )	Description
0... <b>[Max PID feedback] P , F 2</b>	Setting range Factory setting: 100

**[Max PID feedback] P , F 2 ★**

Maximum PID feedback.

This parameter can be accessed if **[PID Feedback] P , F** is not set to **[Not Configured] n o .**

Setting ( )	Description
<b>[Min PID feedback] P , F 1...32,767</b>	Setting range <b>Factory setting:</b> 1,000

**[PID feedback] P F ★**

Value for PID feedback, display only.

This parameter can be accessed if **[PID Feedback] P , F** is not set to **[Not Configured] n o .**

Setting	Description
0...65,535	Setting range <b>Factory setting:</b> 0

**[Min Fbk Warning] P A L ★**

Minimum feedback level warning.

This parameter can be accessed if **[PID Feedback] P , F** is not set to **[Not Configured] n o .**

Setting ( )	Description
0...65,535	Setting range <b>Factory setting:</b> 100

**[Max Fbk Warning] P A H ★**

Maximum feedback level warning.

This parameter can be accessed if **[PID Feedback] P , F** is not set to **[Not Configured] n o .**

Setting ( )	Description
0...65,535	Setting range <b>Factory setting:</b> 1,000



## [Reference frequency] $r F$ - Menu

### Access

[Complete settings] → [Fan] → [PID controller] → [Reference frequency]

### About This Menu

**NOTE:** This function cannot be used with some other functions. Follow the instructions about the compatibility of functions.

### [Intern PID Ref] $P_{i1}$ ★

Internal PID controller reference.

This parameter can be accessed if [PID Feedback]  $P_{iF}$  is not set to [Not Configured]  $n o$ .

Setting	Code / Value	Description
[No]	$n o$	The PID controller reference is given by [Ref Freq 1 Config] $F_{r1}$ or [Ref.1B channel] $F_{r1b}$ with summing/subtraction/multiplication functions. Refer to the block diagram ( <a href="#">see page 305</a> ). <b>Factory setting</b>
[Yes]	$y e s$	The PID controller reference is internal via [Internal PID ref] $r P_{i1}$ .

### [Ref Freq 1 Config] $F_{r1}$ ★

Configuration reference frequency 1.

This parameter can be accessed if:

- [PID Feedback]  $P_{iF}$  is not set to [Not Configured]  $n o$ , and
- [Intern PID Ref]  $P_{i1}$  is set to [No]  $n o$ .

Setting	Code / Value	Description
[Not Configured]	$n o$	Not assigned
[AI1]	$A_{i1}$	Analog input AI1 <b>Factory Setting</b>
[AI2]...[AI3]	$A_{i2}...A_{i3}$	Analog input AI2...AI3
[AI4]...[AI5]	$A_{i4}...A_{i5}$	Analog input AI4...AI5 if VW3A3203 I/O extension module has been inserted
[Ref Frequency via DI]	$u P d t$	Up/Down function is assigned by DIx
[Ref. Freq-Modbus]	$M o d b$	Reference frequency via Modbus
[Ref. Freq-CANopen]	$C A n$	Reference frequency via CANopen if a CANopen module has been inserted
[Ref. Freq-Com. Module]	$n E t$	Reference frequency via fieldbus module if a fieldbus module has been inserted
[Embedded Ethernet]	$E t H$	Embedded Ethernet
[PulseInput Assignment On DI5]...[PulseInput Assignment On DI6]	$P_{i5}...P_{i6}$	Digital input DI5...DI6 used as pulse input

### [Min PID reference] $P_{iP1}$ ★

Minimum PID reference.

This parameter can be accessed if [PID Feedback]  $P_{iF}$  is not set to [Not Configured]  $n o$ .

Setting ( )	Description
[Min PID feedback] $P_{iF1}$ ...[Max PID reference] $P_{iP2}$	Setting range <b>Factory setting:</b> 150

**[Max PID reference] P, P2 ★**

Maximum PID reference.

This parameter can be accessed if **[PID Feedback] P, F** is not set to **[Not Configured] no**.

Setting ( )	Description
<b>[Min PID reference] P, P1...[Max PID feedback] P, F2</b>	Setting range <b>Factory setting:</b> 900

**[Internal PID ref] r P, ★**

Internal PID controller reference.

This parameter can be accessed if:

- **[PID Feedback] P, F** is not set to **[Not Configured] no**, and
- **[Intern PID Ref] P, r** is set to **[Yes] YES**.

Setting ( )	Description
<b>[Min PID reference] P, P1...[Max PID reference] P, P2</b>	Setting range <b>Factory setting:</b> 150

**[Auto/Manual assign.] P A, ★**

Auto/Manual select input.

This parameter can be accessed if **[PID Feedback] P, F** is not set to **[Not Configured] no**.

Setting	Code / Value	Description
<b>[Not Assigned]</b>	no	Not assigned <b>Factory setting</b>
<b>[DI1]...[DI6]</b>	L, I...L, I6	Digital input DI1...DI6
<b>[DI11]...[DI16]</b>	L, I I...L, I6	Digital input DI11...DI16 if VW3A3203 I/O extension module has been inserted
<b>[CD00]...[CD10]</b>	C d 0 0...C d 1 0	Virtual digital input CMD.0...CMD.10 in <b>[I/O profile]</b> , no configuration
<b>[CD11]...[CD15]</b>	C d 1 1...C d 1 5	Virtual digital input CMD.11...CMD.15 regardless of configuration
<b>[C100]...[C110]</b>	C 1 0 0...C 1 1 0	Virtual digital input CMD1.0...CMD1.10 with integrated Modbus Serial in <b>[I/O profile]</b> , no configuration
<b>[C111]...[C115]</b>	C 1 1 1...C 1 1 5	Virtual digital input CMD1.11...CMD1.15 with integrated Modbus Serial regardless of configuration
<b>[C200]...[C210]</b>	C 2 0 0...C 2 1 0	Virtual digital input CMD2.0...CMD2.10 with CANopen® fieldbus module in <b>[I/O profile]</b> , no configuration
<b>[C211]...[C215]</b>	C 2 1 1...C 2 1 5	Virtual digital input CMD2.11...CMD2.15 with CANopen® fieldbus module regardless of configuration
<b>[C300]...[C310]</b>	C 3 0 0...C 3 1 0	Virtual digital input CMD3.0...CMD3.10 with a fieldbus module in <b>[I/O profile]</b> , no configuration
<b>[C311]...[C315]</b>	C 3 1 1...C 3 1 5	Virtual digital input CMD3.11...CMD3.15 with a fieldbus module regardless of configuration
<b>[C500]...[C510]</b>	C 5 0 0...C 5 1 0	Virtual digital input CMD5.0...CMD5.10 with integrated Ethernet Modbus TCP in <b>[I/O profile]</b> , no configuration
<b>[C511]...[C515]</b>	C 5 1 1...C 5 1 5	Virtual digital input CMD5.11...CMD5.15 with integrated Ethernet Modbus TCP regardless of configuration

**[Manual PID Reference] P , Π ★**

Manual PID reference.

Reference input in manual mode.

This parameter can be accessed if:

- **[PID Feedback] P , F** is not set to **[Not Configured] n o**, and
- **[Auto/Manual assign.] P R u** is not set to **[No] n o**.

The preset speeds are active on the manual reference if they have been configured.

Setting	Code / Value	Description
[No]	n o	Not assigned <b>Factory setting</b>
[AI1]...[AI3]	A , 1...A , 3	Analog input AI1...AI3
[AI4]...[AI5]	A , 4...A , 5	Analog input AI4...AI5 if VW3A3203 I/O extension module has been inserted
[Ref.Freq-Rmt.Term]	L C C	Display terminal source
[Ref. Freq-Modbus]	Π d b	Reference frequency via Modbus
[Ref. Freq- CANopen]	C A n	Reference frequency via CANopen
[Ref. Freq-Com. Module]	n E E	Reference frequency via Com Module
[Embedded Ethernet]	E t H	Embedded Ethernet source
[PulseInput Assignment On DI5]...[PulseInput Assignment On DI6]	P , 5...P , 6	Digital input DI5...DI6 used as pulse input

## [PID preset references] *P r 1* - Menu

### Access

[Complete settings] → [Fan] → [PID controller] → [Reference frequency] → [PID preset references]

### About This Menu

The function can be accessed if [PID feedback ass.] *P f* is assigned.

### [2 PID Preset Assign] *P r 2*

2 PID Preset assignment.

If the assigned input or bit is at 0, the function is inactive.

If the assigned input or bit is at 1, the function is active.

Setting	Code / Value	Description
[Not Assigned]	<i>n o</i>	Not assigned <b>Factory setting</b>
[DI1]...[DI6]	<i>L 1 L ... L 6</i>	Digital input DI1...DI6
[DI11]...[DI16]	<i>L 11 L ... L 16</i>	Digital input DI11...DI16 if VW3A3203 I/O extension module has been inserted
[CD00]...[CD10]	<i>C d 0 0 ... C d 1 0</i>	Virtual digital input CMD.0...CMD.10 in [I/O profile] configuration
[CD11]...[CD15]	<i>C d 1 1 ... C d 1 5</i>	Virtual digital input CMD.11...CMD.15 regardless of configuration
[C100]...[C110]	<i>C 1 0 0 ... C 1 1 0</i>	Virtual digital input CMD1.0...CMD1.10 with integrated Modbus Serial in [I/O profile] configuration
[C111]...[C115]	<i>C 1 1 1 ... C 1 1 5</i>	Virtual digital input CMD1.11...CMD1.15 with integrated Modbus Serial regardless of configuration
[C200]...[C210]	<i>C 2 0 0 ... C 2 1 0</i>	Virtual digital input CMD2.0...CMD2.10 with CANopen® fieldbus module in [I/O profile] configuration
[C211]...[C215]	<i>C 2 1 1 ... C 2 1 5</i>	Virtual digital input CMD2.11...CMD2.15 with CANopen® fieldbus module regardless of configuration
[C300]...[C310]	<i>C 3 0 0 ... C 3 1 0</i>	Virtual digital input CMD3.0...CMD3.10 with a fieldbus module in [I/O profile] configuration
[C311]...[C315]	<i>C 3 1 1 ... C 3 1 5</i>	Virtual digital input CMD3.11...CMD3.15 with a fieldbus module regardless of configuration
[C500]...[C510]	<i>C 5 0 0 ... C 5 1 0</i>	Virtual digital input CMD5.0...CMD5.10 with integrated Ethernet Modbus TCP in [I/O profile] configuration
[C511]...[C515]	<i>C 5 1 1 ... C 5 1 5</i>	Virtual digital input CMD5.11...CMD5.15 with integrated Ethernet Modbus TCP regardless of configuration
[DI1 (Low level)]...[DI6 (Low level)]	<i>L 1 L ... L 6 L</i>	Digital input DI1...DI6 used at low level
[DI11 (Low level)]...[DI16 (Low level)]	<i>L 11 L ... L 16 L</i>	Digital input DI11...DI16 used at low level if VW3A3203 I/O extension module has been inserted

### [4 PID Preset Assign] *P r 4*

4 PID Preset assignment.

Identical to [2 PID Preset Assign] *P r 2* (see page 524).

Verify that [2 PID Preset Assign] *P r 2* has been assigned before assigning this function.

**[Ref PID Preset 2]  $r P 2$  ★**

Second PID preset reference.

This parameter can be accessed only if **[2 PID Preset Assign]  $P r 2$**  is assigned.

Setting ( )	Description
<b>[Min PID reference] <math>P , P 1</math>...[Max PID reference] <math>P , P 2</math></b>	Setting range <b>Factory setting:</b> 300

**[Ref PID Preset 3]  $r P 3$  ★**

Third PID preset reference.

This parameter can be accessed only if **[4 preset PID ref.]  $P r 4$**  is assigned.

Setting ( )	Description
<b>[Min PID reference] <math>P , P 1</math>...[Max PID reference] <math>P , P 2</math></b>	Setting range <b>Factory setting:</b> 600

**[Ref PID Preset 4]  $r P 4$  ★**

Fourth PID preset reference.

This parameter can be accessed only if **[2 preset PID ref.]  $P r 2$**  and **[4 preset PID ref.]  $P r 4$**  are assigned.

Setting ( )	Description
<b>[Min PID reference] <math>P , P 1</math>...[Max PID reference] <math>P , P 2</math></b>	Setting range <b>Factory setting:</b> 900

## [Reference frequency] $r F$ - Menu

### Access

[Complete settings] → [Fan] → [PID controller] → [Reference frequency]

### [Predictive Speed Ref] $F P$ , ★

Speed reference assignment.

This parameter can be accessed if [Access Level]  $L R C$  is set to [Expert]  $E P r$ .

Setting	Code / Value	Description
[No]	$n o$	Not assigned <b>Factory setting</b>
[AI1]...[AI3]	$A , 1 \dots A , 3$	Analog input AI1...AI3
[AI4]...[AI5]	$A , 4 \dots A , 5$	Analog input AI4...AI5 if VW3A3203 I/O extension module has been inserted
[Ref. Freq- Rmt.Term]	$L C C$	Reference frequency via remote terminal
[Ref. Freq-Modbus]	$M d b$	Reference frequency via Modbus
[Ref. Freq-CANopen]	$C A n$	Reference frequency via CANopen
[Ref. Freq-Com. Module]	$n E t$	Reference frequency via communication module
[Embedded Ethernet]	$E t H$	Embedded Ethernet
[PulseInput Assignment On DI5]...[PulseInput Assignment On DI6]	$P , 5 \dots P , 6$	Digital input DI5...DI6 used as pulse input

### [Speed input %] $P S r$ ★

PID speed input % reference.

This parameter can be accessed if [Access Level]  $L R C$  is set to [Expert]  $E P r$ .

Setting ( )	Description
1...100%	Setting range <b>Factory setting:</b> 100%

## [Settings] 5 L - Menu

### Access

[Complete settings] → [Fan] → [PID controller] → [Settings]

### About This Menu

Following parameters can be accessed if [PID feedback ass.]  $P_{IF}$  is not set to [Not Configured]  $n \emptyset$ .

**NOTE:** This function cannot be used with some other functions. Follow the instructions about the compatibility of functions.

### [PID Prop.Gain] $r P G$ ★

Proportional gain.

Setting ( )	Description
0.01...100.00	Setting range <b>Factory setting:</b> 1.00

### [PID Intgl.Gain] $r I G$ ★

Integral gain.

Setting ( )	Description
0.01...100.00	Setting range <b>Factory setting:</b> 1.00

### [PID derivative gain] $r d G$ ★

Derivative gain.

Setting ( )	Description
0.00...100.00	Setting range <b>Factory setting:</b> 0.00

### [PID ramp] $P r P$ ★

PID acceleration/deceleration ramp, defined to go from [Min PID reference]  $P_{P1}$  to [Max PID reference]  $P_{P2}$  and conversely.

Setting ( )	Description
0.0...99.9 s	Setting range <b>Factory setting:</b> 0.0 s

### [PID Inversion] $P I C$ ★

PID inversion.

Setting	Code / Value	Description
[No]	$n \emptyset$	No <b>Factory setting</b>
[YES]	$Y E S$	Yes

**[PID Min Output] P o L ★**

PID controller minimum output in Hz.

Setting ( )	Description
0.0...500.0 Hz	Setting range <b>Factory setting:</b> 0.0 Hz

**[PID Max Output] P o H ★**

PID controller maximum output in Hz.

Setting ( )	Description
0.0...500.0 Hz	Setting range <b>Factory setting:</b> 60.0 Hz

**[PID error Warning] P E r ★**

PID error warning.

Setting ( )	Description
0...65,535	Setting range <b>Factory setting:</b> 100

**[PID Integral OFF] P , 5 ★**

Integral shunt.

If the assigned input or bit is at 0, the function is inactive (the PID integral is enabled).

If the assigned input or bit is at 1, the function is active (the PID integral is disabled).

Setting	Code / Value	Description
[Not Assigned]	n o	Not assigned <b>Factory setting</b>
[DI1]...[DI6]	L , 1...L , 6	Digital input DI1...DI6
[DI11]...[DI16]	L , 11...L , 16	Digital input DI11...DI16 if VW3A3203 I/O extension module has been inserted
[CD00]...[CD10]	C d 0 0...C d 1 0	Virtual digital input CMD.0...CMD.10 in <b>[I/O profile] , o</b> configuration
[CD11]...[CD15]	C d 1 1...C d 1 5	Virtual digital input CMD.11...CMD.15 regardless of configuration
[C100]...[C110]	C 1 0 0...C 1 1 0	Virtual digital input CMD1.0...CMD1.10 with integrated Modbus Serial in <b>[I/O profile] , o</b> configuration
[C111]...[C115]	C 1 1 1...C 1 1 5	Virtual digital input CMD1.11...CMD1.15 with integrated Modbus Serial regardless of configuration
[C200]...[C210]	C 2 0 0...C 2 1 0	Virtual digital input CMD2.0...CMD2.10 with CANopen® fieldbus module in <b>[I/O profile] , o</b> configuration
[C211]...[C215]	C 2 1 1...C 2 1 5	Virtual digital input CMD2.11...CMD2.15 with CANopen® fieldbus module regardless of configuration
[C300]...[C310]	C 3 0 0...C 3 1 0	Virtual digital input CMD3.0...CMD3.10 with a fieldbus module in <b>[I/O profile] , o</b> configuration
[C311]...[C315]	C 3 1 1...C 3 1 5	Virtual digital input CMD3.11...CMD3.15 with a fieldbus module regardless of configuration
[C500]...[C510]	C 5 0 0...C 5 1 0	Virtual digital input CMD5.0...CMD5.10 with integrated Ethernet Modbus TCP in <b>[I/O profile] , o</b> configuration
[C511]...[C515]	C 5 1 1...C 5 1 5	Virtual digital input CMD5.11...CMD5.15 with integrated Ethernet Modbus TCP regardless of configuration



**[PID acceleration time] ACCP** ★

PID: acceleration during start-up.

PID start ramp can be applied before starting the PID controller to allow reaching quickly the PID reference without increasing PID gains. If configured, the **[Start Accel Ramp] ACCS** is applied up to **[Low Speed] LSP** instead of **[PID acceleration time] ACCP**.

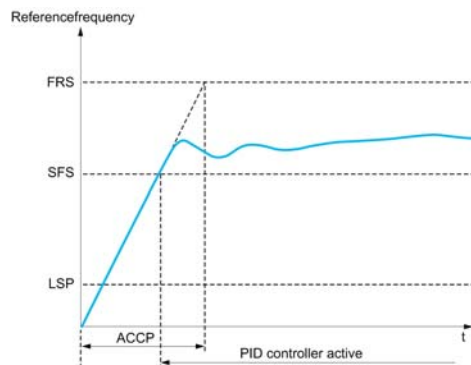

Setting ( )	Description
0.01...99,99 s <sup>(1)</sup>	Setting range <b>Factory setting:</b> 0.50 s
1	Range 0.01 to 99.99 s or 0.1 to 999.9 s or 1...6,000 s according to <b>[Ramp increment] INC</b> .

**[PID Start Ref Freq] SFS** ★

PID: speed reference for start-up.

Setting ( )	Description
0.0...500.0 Hz	Setting range If <b>[PID Start Ref Freq] SFS</b> is lower than <b>[Low speed] LSP</b> , this function has no effect. <b>Factory setting:</b> 0.0 Hz

## Section 7.29

### [Fan] - [Feedback monitoring]

---

#### [Feedback monitoring] F K Π - Menu

##### Access

[Complete settings] → [Fan] → [Feedback monitoring]

##### About This Menu

Identical to [Feedback monitoring] F K Π - Menu (*see page 365*).

## Section 7.30

### [Fan] - [Jump frequency]

#### [Jump frequency] *JLF* - Menu

##### Access

[Complete settings] → [Fan] → [Jump frequency]

##### About This Menu

This function helps to prevent prolonged operation within an adjustable range around the regulated frequency.

This function can be used to help to prevent a speed, which could cause resonance, being reached. Setting the function to 0 renders it inactive.

#### [Skip Frequency] *JPF*

Jump frequency.

Setting ( )	Description
0.0...500.0 Hz	Setting range <b>Factory setting:</b> 0.0 Hz

#### [Skip Frequency 2] *JF2*

Jump frequency 2.

Setting ( )	Description
0.0...500.0 Hz	Setting range <b>Factory setting:</b> 0.0 Hz

#### [3rd Skip Frequency] *JF3*

Jump frequency 3.

Setting ( )	Description
0.0...500.0 Hz	Setting range <b>Factory setting:</b> 0.0 Hz

#### [Skip.Freq.Hysteresis] *JFH* ★

Jump frequency bandwidth.

This parameter can be accessed if at least one skip frequency *JPF*, *JF2*, or *JF3* is different from 0.

Skip frequency range: between  $JPF - JFH$  and  $JPF + JFH$  for example.

This adjustment is common to the 3 frequencies *JPF*, *JF2*, *JF3*.

Setting ( )	Description
0.1...10.0 Hz	Setting range <b>Factory setting:</b> 1.0 Hz

## Section 7.31

### [Fan]

#### [Fan] C S F R - Menu

##### Access

[Complete settings] → [Fan]

#### [Auto Fault Reset] *F L r*

This function can be used to automatically perform individual or multiple Fault Resets. If the cause of the error that has triggered the transition to the operating state Fault disappears within while this function is active, the drive resumes normal operation. While the Fault Reset attempts are performed automatically, the output signal **[Operating state Fault]** is not available. If the attempts to perform the Fault Reset are not successful, the drive remains in the operating state Fault and the output signal **[Operating state Fault]** becomes active.

** WARNING**

**UNANTICIPATED EQUIPMENT OPERATION**

- Verify that activating this function does not result in unsafe conditions.
- Verify that the fact that the output signal "Operating state Fault" is not available while this function is active does not result in unsafe conditions.

**Failure to follow these instructions can result in death, serious injury, or equipment damage.**

The drive error relay remains activated if this function is active. The speed reference and the operating direction must be maintained.

It is recommended to use 2-wire control (**[2/3-wire control] E C C** is set to **[2-Wire Control] 2 C** and **[2-wire type] E C E** is set to **[Level] L E L**).

If the restart has not taken place once the configurable time **[Fault Reset Time] E R r** has elapsed, the procedure is aborted and the drive remains locked until it is turned off and then on again.

The detected error codes, which permit this function, are listed.

Setting	Code / Value	Description
[No]	n o	Function inactive <b>Factory setting</b>
[Yes]	Y E 5	Automatic restart, after locking in error state, if the detected error has disappeared and the other operating conditions permit the restart. The restart is performed by a series of automatic attempts separated by increasingly longer waiting periods: 1 s, 5 s, 10 s, then 1 minute for the following attempts.

**[Catch On Fly] FLr**

Catch on the fly function assignment.

Used to enable a smooth restart if the run command is maintained after the following events:

- Loss of line supply or disconnection.
- Clearance of current detected error or automatic restart.
- Freewheel stop (a delay of 5 times the **[Rotor Time Const] LrH** is applied before taking the next run command into account).

The speed given by the drive resumes from the estimated speed of the motor at the time of the restart, then follows the ramp to the reference speed.

This function requires 2-wire level control.

When the function is operational, it activates at each run command, resulting in a slight delay of the current (0.5 s max).

**[Catch On Fly] FLr** is forced to **[No] no** if **[Auto DC Injection] ADL** is set to **[Continuous] LE**.

Setting	Code / Value	Description
<b>[No]</b>	<b>no</b>	Function inactive <b>Factory setting</b>
<b>[Yes]</b>	<b>YES</b>	Function active

## Section 7.32

### [Generic functions] - [Speed limits]

#### [Speed limits] 5 L P - Menu

##### Access

[Complete settings] → [Generic functions] → [Speed limits]

##### About This Menu

This function defines how the acceleration and deceleration are controlled during start and stop of the pump.

The pump working area is within the speed range [Low Speed] L 5 P - [High Speed] H 5 P.

The minimum speed is provided by the pump manufacturer according to the application.

Running below the minimum speed and/or starting the pump with a long acceleration ramp time has an impact on the lubrication of the seal, on the cooling of the impeller and the bearings.

A specific check-valve deceleration ramp is available to reduce any large variation of pressure that can generate an instability of the valve.

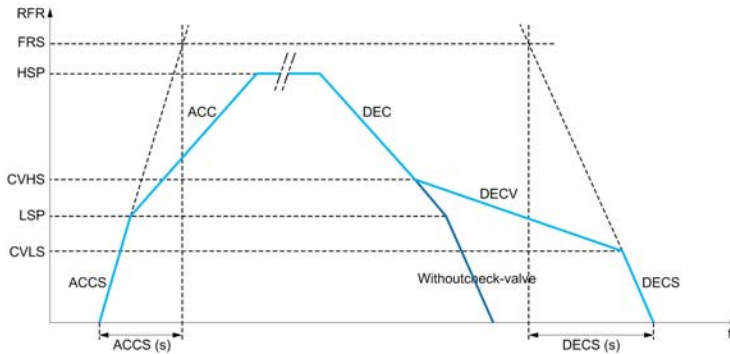

When the pump starts, the pump accelerates up to [Low Speed] L 5 P according to [Start Accel Ramp] ACCS. When the pump speed is above [Low Speed] L 5 P, the pump acceleration and deceleration are managed according to [Acceleration] ACC and [Deceleration] DEC if no other function is activated.

When the pump stops:

- The pump decelerates down to [Check Valve Spd 2] CVHS according to [Deceleration] DEC
- The pump decelerates from [Check Valve Spd 2] CVHS to [Check Valve Spd 1] CVLS according to [Dec. Check Valve] DECV
- The pump decelerates from [Check Valve Spd 1] CVLS to zero speed according to [Deceleration on Stop] DECS

If [Start Accel Ramp] ACCS = 0, the start ramp is ignored and [Acceleration] ACC is used to start the pump.

If [Dec. Check Valve] DECV = 0, the check-valve ramp is ignored and is used to decelerate down to [Low Speed] L 5 P, then [Deceleration on Stop] DECS is used (see below).

If [Deceleration on Stop] DECS = 0, the normal deceleration [Deceleration] DEC is used to stop the pump.

#### [Low Speed] L 5 P

Motor frequency at low speed.

Setting ( )	Description
0...500 Hz	Setting range Factory setting: 0 Hz

**[High Speed] H 5 P**

Motor frequency at high speed.

Setting ( )	Description
0...500 Hz	Setting range <b>Factory setting:</b> 500 Hz

**[Ref Freq Template] b 5 P**

Low speed management (template).

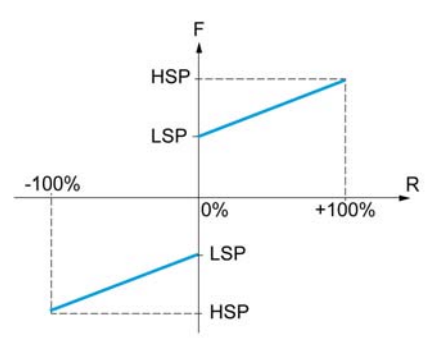
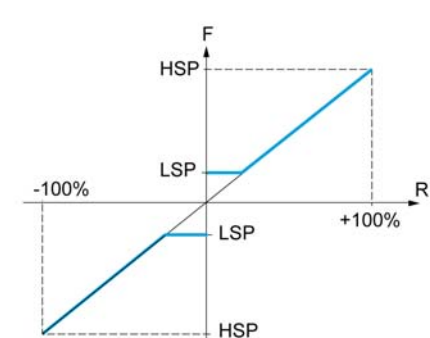
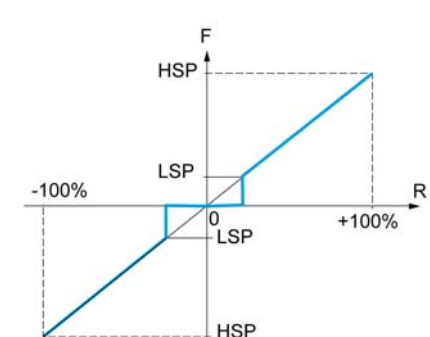
Setting ( )	Code / Value	Description
[Standard]	b 5 d	 <p><b>F</b> Frequency <b>R</b> Reference</p> <p>At reference = 0, the frequency = <b>[Low speed] L 5 P</b> <b>Factory setting</b></p>
[Pedestal]	b L 5	 <p><b>F</b> Frequency <b>R</b> Reference</p> <p>At reference = 0 to <b>[Low speed] L 5 P</b>, the frequency = <b>[Low speed] L 5 P</b></p>
[Deadband]	b n 5	 <p><b>F</b> Frequency <b>R</b> Reference</p> <p>At reference = 0 to <b>L 5 P</b> the frequency = 0</p>

Setting ( )	Code / Value	Description
[Deadband 0]	b n 5 0	<div data-bbox="746 232 1157 555" data-label="Figure"> </div> <p data-bbox="735 564 877 613"> <b>F</b> Frequency  <b>R</b> Reference         </p> <p data-bbox="735 640 1441 770">           This operation is the same as <b>[Standard] b 5 d</b>, except that in the following cases at zero reference, the frequency = 0: The signal is less than <b>[Min value]</b>, which is greater than 0 (example: 1 Vdc on a 2–10 Vdc input). The signal is greater than <b>[Min value]</b>, which is greater than <b>[Max value]</b> (example: 11 Vdc on a 10–0 Vdc input).         </p> <p data-bbox="735 775 1441 824">           If the input range is configured as “bidirectional”, the operation remains identical to <b>[Standard] b 5 d</b>.         </p> <p data-bbox="735 828 1441 904">           This parameter defines how the speed reference is taken into account, for analog inputs and pulse input only. In the case of the PID controller, this is the PID output reference.         </p> <p data-bbox="735 909 1441 958">           The limits are set by the <b>[Low speed] L 5 P</b> and <b>[High speed] H 5 P</b> parameters         </p>



## Section 7.33

### [Generic functions] - [Ramp]

#### [Ramp] *rAMP* - Menu

##### Access

[Complete settings] → [Generic functions] → [Ramp]

#### [Ramp Type] *rPt*

Type of ramp.

Setting	Code / Value	Description
[Linear]	<i>Lin</i>	Linear ramp <b>Factory setting</b>
[S-Ramp]	<i>S</i>	S ramp
[U-Ramp]	<i>u</i>	U ramp
[Customized]	<i>cus</i>	Customer ramp

#### [Ramp increment] *inc*

This parameter is valid for [Acceleration] *ACC*, [Deceleration] *DEC*, [Acceleration 2] *ACC2* and [Deceleration 2] *DEC2*.

This table presents the parameter settings:

Setting ( )	Code / Value	Description
[0.01]	<i>0.01</i>	Ramp up to 99.99 seconds
[0.1]	<i>0.1</i>	Ramp up to 999.9 seconds <b>Factory setting</b>
[1]	<i>1</i>	Ramp up to 6,000 seconds

#### [Acceleration] *ACC*

Time to accelerate from 0 to the [Nominal Motor Freq] *F<sub>r5</sub>*.

To have repeatability in ramps, the value of this parameter must be set according to the possibility of the application.

Setting ( )	Description
0.00...6,000.00 s <sup>(1)</sup>	Setting range <b>Factory setting:</b> 10.00 s
<b>(1)</b> Range 0.01 to 99.99 s or 0.1 to 999.9 s or 1 to 6,000 according to [Ramp increment] <i>inc</i>	

#### [Deceleration] *DEC*

Time to decelerate from the [Nominal Motor Freq] *F<sub>r5</sub>* to 0.

To have repeatability in ramps, the value of this parameter must be set according to the possibility of the application.

Setting ( )	Description
0.00...6,000.00 s <sup>(1)</sup>	Setting range <b>Factory setting:</b> 10.00 s
<b>(1)</b> Range 0.01 to 99.99 s or 0.1 to 999.9 s or 1 to 6,000 according to [Ramp increment] <i>inc</i>	

**[Begin Acc round] E A 1 ★**

Rounding of start of acceleration ramp as a % of the **[Acceleration] A C C** or **[Acceleration 2] A C 2** ramp time.

Can be set from 0 to 100%.

This parameter can be accessed if the **[Ramp type] r P E** is set to **[Customized] C U 5**.

Setting ( )	Description
0...100%	Setting range <b>Factory setting:</b> 10%

**[End Acc round] E A 2 ★**

Rounding of end of acceleration ramp as a % of the **[Acceleration] A C C** or **[Acceleration 2] A C 2** ramp time.

Can be set between 0 and (100% - **[Begin Acc round] E A 1**).

This parameter can be accessed if the **[Ramp type] r P E** is set to **[Customized] C U 5**.

Setting ( )	Description
0...100%	Setting range <b>Factory setting:</b> 10%

**[Begin Dec round] E A 3 ★**

Rounding of start of deceleration ramp as a % of the **[Deceleration] d E C** or **[Deceleration 2] d E 2** ramp time.

Can be set from 0 to 100%.

This parameter can be accessed if the **[Ramp type] r P E** is set to **[Customized] C U 5**.

Setting ( )	Description
0...100%	Setting range <b>Factory setting:</b> 10%

**[End Dec round] E A 4 ★**

Rounding of end of deceleration ramp as a % of the **[Deceleration] d E C** or **[Deceleration 2] d E 2** ramp time.

Can be set between 0 and (100% - **[Begin Dec round] E A 3**).

This parameter can be accessed if the **[Ramp type] r P E** is **[Customized] C U 5**.

Setting ( )	Description
0...100%	Setting range <b>Factory setting:</b> 10%

**[Dec.Ramp Adapt] brA**

Deceleration ramp adaptation.

**NOTICE****DAMAGE TO THE MOTOR**

Only set this parameter to **YES** or **no** if the connected motor is a permanent magnet synchronous motor. Other settings demagnetize permanent magnet synchronous motors.

**Failure to follow these instructions can result in equipment damage.**

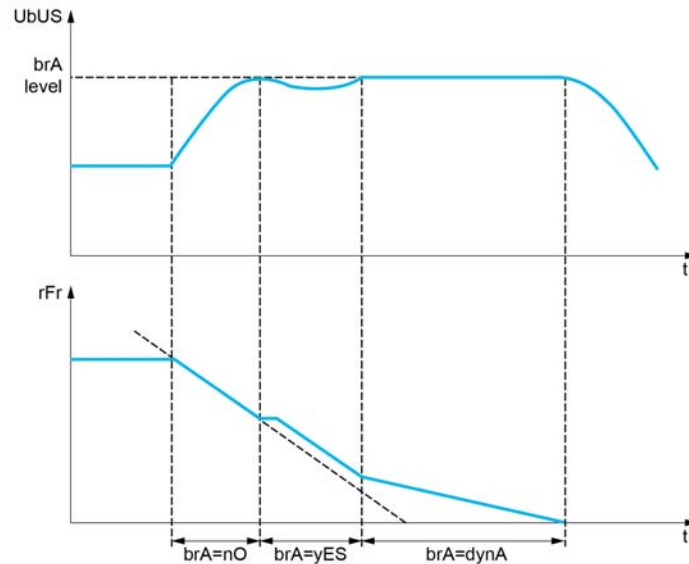

Activating this function automatically adapts the deceleration ramp, if this has been set at a too low value according to the inertia of the load, which can cause an overvoltage detected error.

The function is incompatible with applications requiring:

- Positioning on a ramp
- The use of a braking resistor (the resistor would not operate correctly).

Setting	Code / Value	Description
<b>[No]</b>	<b>no</b>	Function inactive
<b>[Yes]</b>	<b>YES</b>	Function active, for applications that do not require strong deceleration <b>Factory setting</b>
<b>[High Torque]</b>	<b>dynA</b>	Addition of a constant current flow component. The <b>[High torq. A] dynA</b> selection appears depending on the rating of the drive and <b>[Motor control type] CLT</b> . It enables stronger deceleration to be obtained than with <b>[Yes] YES</b> . Use comparative testing to determine your selection When <b>[Dec.Ramp Adapt] brA</b> is configured on <b>[High torq. x] dynX</b> , the dynamic performances for braking are improved by the addition of a current flow component. The aim is to increase the iron loss and magnetic energy stored in the motor.

## Section 7.34

### [Generic functions] - [Ramp switching]

#### [Ramp switching] *r P t* - Menu

##### Access

[Complete settings] → [Generic functions] → [Ramp switching]

#### [Ramp 2 Thd] *F r t*

Ramp 2 frequency threshold

The second ramp is switched if the value of [Ramp 2 Thd] *F r t* is not 0 (0 deactivates the function) and the output frequency is greater than [Ramp 2 Thd] *F r t*.

Threshold ramp switching can be combined with [Ramp Switch Assign] *r P 5* switching as follows:

DI or Bit	Frequency	Ramp
0	< <i>F r t</i>	<i>R C C, d E C</i>
0	> <i>F r t</i>	<i>R C C, d E 2</i>
1	< <i>F r t</i>	<i>R C C, d E 2</i>
1	> <i>F r t</i>	<i>R C C, d E 2</i>

Setting ( )	Description
0.0...500.0 Hz according to the drive rating	Setting range <b>Factory setting:</b> 0.0 Hz

#### [Ramp Switch Assign] *r P 5*

Ramp switching.

Setting	Code / Value	Description
[Not Assigned]	<i>n o</i>	Not assigned <b>Factory setting</b>
[DI1]...[DI6]	<i>L , I ... L , I 6</i>	Digital input DI1...DI6
[DI11]...[DI16]	<i>L , I I ... L , I 1 6</i>	Digital input DI11...DI16, if VW3A3203 I/O extension module has been inserted
[CD00]...[CD10]	<i>C d 0 0 ... C d 1 0</i>	Virtual digital input CMD.0...CMD.10 in [I/O profile] , <i>o</i> configuration
[CD11]...[CD15]	<i>C d 1 1 ... C d 1 5</i>	Virtual digital input CMD.11...CMD.15 regardless of configuration
[C100]...[C110]	<i>C 1 0 0 ... C 1 1 0</i>	Virtual digital input CMD1.0...CMD1.10 with integrated Modbus serial in [I/O profile] , <i>o</i> configuration
[C111]...[C115]	<i>C 1 1 1 ... C 1 1 5</i>	Virtual digital input CMD1.11...CMD1.15 with integrated Modbus serial regardless of configuration
[C200]...[C210]	<i>C 2 0 0 ... C 2 1 0</i>	Virtual digital input CMD2.0...CMD2.10 with CANopen® fieldbus module in [I/O profile] , <i>o</i> configuration
[C211]...[C215]	<i>C 2 1 1 ... C 2 1 5</i>	Virtual digital input CMD2.11...CMD2.15 with CANopen® fieldbus module regardless of configuration
[C300]...[C310]	<i>C 3 0 0 ... C 3 1 0</i>	Virtual digital input CMD3.0...CMD3.10 with a fieldbus module in [I/O profile] , <i>o</i> configuration
[C311]...[C315]	<i>C 3 1 1 ... C 3 1 5</i>	Virtual digital input CMD3.11...CMD3.15 with a fieldbus module regardless of configuration
[C500]...[C510]	<i>C 5 0 0 ... C 5 1 0</i>	Virtual digital input CMD5.0...CMD5.10 with integrated Ethernet ModbusTCP in [I/O profile] , <i>o</i> configuration
[C511]...[C515]	<i>C 5 1 1 ... C 5 1 5</i>	Virtual digital input CMD5.11...CMD5.15 with integrated Ethernet ModbusTCP regardless of configuration

**[Acceleration 2]  $r P 2$  ★**

Acceleration 2 ramp time.

Time to accelerate from 0 to the **[Nominal Motor Freq]  $F r 5$** . To have repeatability in ramps, the value of this parameter must be set according to the possibility of the application.

This parameter can be accessed if **[Ramp 2 Thd]  $F r E$**  is greater than 0 or if **[Ramp Switch Assign]  $r P 5$**  is assigned.

Setting ( )	Description
0.0...6,000 s <sup>(1)</sup>	Setting range <b>Factory setting:</b> 5.0 s
<b>(1)</b> Range 0.01 to 99.99 s or 0.1 to 999.9 s or 1...6,000 s according to <b>[Ramp increment] <math>i n r</math></b> .	

**[Deceleration 2]  $d E 2$  ★**

Time to decelerate from the **[Nominal Motor Freq]  $F r 5$**  to 0. To have repeatability in ramps, the value of this parameter must be set according to the possibility of the application.

This parameter can be accessed if:

- **[Ramp 2 Thd]  $F r E$**  is greater than 0, or
- **[Ramp Switch Assign]  $r P 5$**  is assigned.

Setting ( )	Description
0.0...6,000 s <sup>(1)</sup>	Setting range <b>Factory setting:</b> 5.0 s
<b>(1)</b> Range 0.01 to 99.99 s or 0.1 to 999.9 s or 1...6,000 s according to <b>[Ramp increment] <math>i n r</math></b> .	

## Section 7.35

### [Generic functions] - [Stop configuration]

#### [Stop configuration] 5 5 5 - Menu

##### Access

[Complete settings] → [Generic functions] → [Stop configuration]

##### About This Menu

**NOTE:** Some types of stops cannot be used with all other functions. Follow the instructions

##### [Type of stop] 5 5 5

Normal stop mode.

Stop mode on disappearance of the run command or appearance of a stop command.

**NOTE:** If [Low speed time out] 5 5 5 is not 0, only ramp type stops may be configured.

Setting	Code / Value	Description
[On Ramp]	r P P	Stop on ramp <b>Factory setting</b>
[Fast stop]	F 5 5	Fast stop
[Freewheel]	n 5 5	Freewheel stop
[DC injection]	d C ,	DC injection stop. Available only if [Motor control type] C 5 5 is not set to [SYN_U VC] 5 5 n u.

**[Freewheel stop ass.] n 5 L**

Freewheel stop.

The stop is activated when the input or the bit changes to 0. If the input returns to state 1 and the run command is still active, the motor will only restart if **[2/3-wire control] L C C** is set to **[2-Wire Control] P C** and if **[2-wire type] L C L** is set to **[Level] L E L** or **[Fwd priority] P F P**. If not, a new run command must be sent.

Setting	Code / Value	Description
<b>[Not Assigned]</b>	n 0	Not assigned <b>Factory setting</b>
<b>[DI1]...[DI6]</b>	L , I...L , 6	Digital input DI1...DI6
<b>[DI11]...[DI16]</b>	L , I I...L , 16	Digital input DI11...DI16 if VW3A3203 I/O extension module has been inserted
<b>[CD00]...[CD10]</b>	C d 0 0...C d 1 0	Virtual digital input CMD.0...CMD.10 in <b>[I/O profile] , P</b> configuration
<b>[CD11]...[CD15]</b>	C d 1 1...C d 1 5	Virtual digital input CMD.11...CMD.15 regardless of configuration
<b>[C100]...[C110]</b>	C 1 0 0...C 1 1 0	Virtual digital input CMD1.0...CMD1.10 with integrated Modbus Serial in <b>[I/O profile] , P</b> configuration
<b>[C111]...[C115]</b>	C 1 1 1...C 1 1 5	Virtual digital input CMD1.11...CMD1.15 with integrated Modbus Serial regardless of configuration
<b>[C200]...[C210]</b>	C 2 0 0...C 2 1 0	Virtual digital input CMD2.0...CMD2.10 with CANopen® fieldbus module in <b>[I/O profile] , P</b> configuration
<b>[C211]...[C215]</b>	C 2 1 1...C 2 1 5	Virtual digital input CMD2.11...CMD2.15 with CANopen® fieldbus module regardless of configuration
<b>[C300]...[C310]</b>	C 3 0 0...C 3 1 0	Virtual digital input CMD3.0...CMD3.10 with a fieldbus module in <b>[I/O profile] , P</b> configuration
<b>[C311]...[C315]</b>	C 3 1 1...C 3 1 5	Virtual digital input CMD3.11...CMD3.15 with a fieldbus module regardless of configuration
<b>[C500]...[C510]</b>	C 5 0 0...C 5 1 0	Virtual digital input CMD5.0...CMD5.10 with integrated Ethernet Modbus TCP in <b>[I/O profile] , P</b> configuration
<b>[C511]...[C515]</b>	C 5 1 1...C 5 1 5	Virtual digital input CMD5.11...CMD5.15 with integrated Ethernet Modbus TCP regardless of configuration

**[Freewheel stop Thd] F F L ★**

Freewheel stop threshold.

Speed threshold below which the motor will switch to freewheel stop.

This parameter supports switching from a ramp stop or a fast stop to a freewheel stop below a low speed threshold.

This parameter can be accessed if:

- **[Type of stop] S L L** is set to **[Fast stop] F S L** or **[Ramp stop] r P P**, and
- **[Auto DC Injection] A d C** is configured.

Setting ( )	Description
0.2...500.0 Hz	Setting range <b>Factory setting:</b> 0.2 Hz

**[Fast stop ass.] F 5 E**

Fast stop.

The stop is activated when the input changes to 0 or the bit changes to 1 (bit in **[I/O profile] , 0** at 0).

If the input returns to state 1 and the run command is still active, the motor will only restart if **[2/3-wire control] E C C** is set to **[2-Wire Control] 2 C** and if **[2-wire type] E C E** is set to **[Level] L E L** or **[Fwd priority] P F 0**.

If not, a new run command must be sent.

**NOTE:** This function cannot be used with some other functions. Follow the instructions about the compatibility of functions.

Setting	Code / Value	Description
[Not Assigned]	n 0	Not assigned <b>Factory setting</b>
[DI1]...[DI6]	L , I...L , 6	Digital input DI1...DI6
[DI11]...[DI16]	L , I I...L , 16	Digital input DI11...DI16 if VW3A3203 I/O extension module has been inserted
[CD00]...[CD10]	C d 0 0...C d 1 0	Virtual digital input CMD.0...CMD.10 in <b>[I/O profile] , 0</b> configuration
[CD11]...[CD15]	C d 1 1...C d 1 5	Virtual digital input CMD.11...CMD.15 regardless of configuration
[C100]...[C110]	C 1 0 0...C 1 1 0	Virtual digital input CMD1.0...CMD1.10 with integrated Modbus Serial in <b>[I/O profile] , 0</b> configuration
[C111]...[C115]	C 1 1 1...C 1 1 5	Virtual digital input CMD1.11...CMD1.15 with integrated Modbus Serial regardless of configuration
[C200]...[C210]	C 2 0 0...C 2 1 0	Virtual digital input CMD2.0...CMD2.10 with CANopen® fieldbus module in <b>[I/O profile] , 0</b> configuration
[C211]...[C215]	C 2 1 1...C 2 1 5	Virtual digital input CMD2.11...CMD2.15 with CANopen® fieldbus module regardless of configuration
[C300]...[C310]	C 3 0 0...C 3 1 0	Virtual digital input CMD3.0...CMD3.10 with a fieldbus module in <b>[I/O profile] , 0</b> configuration
[C311]...[C315]	C 3 1 1...C 3 1 5	Virtual digital input CMD3.11...CMD3.15 with a fieldbus module regardless of configuration
[C500]...[C510]	C 5 0 0...C 5 1 0	Virtual digital input CMD5.0...CMD5.10 with integrated Ethernet Modbus TCP in <b>[I/O profile] , 0</b> configuration
[C511]...[C515]	C 5 1 1...C 5 1 5	Virtual digital input CMD5.11...CMD5.15 with integrated Ethernet Modbus TCP regardless of configuration

**[Ramp Divider] d C F ★**

Fast Stop deceleration ramp reduction coefficient.

This parameter can be accessed if:

- **[Type of stop] 5 E E** is set to **[Fast stop] F 5 E**, and
- **[Fast stop assign.] F 5 E** is not set to **[No] n 0**, and
- **[Stop type] P R 5** is set to **[Fast stop] F 5 E**.

The ramp that is enabled (**[Deceleration] d E C** or **[Deceleration 2] d E 2**) is then divided by this coefficient when stop requests are sent.

Value 0 corresponds to a minimum ramp time.

Setting ( )	Description
0...10	Setting range <b>Factory setting:</b> 4



**[DC Injection Assign] d C ,**

DC injection brake assignment.

**⚠ WARNING****UNINTENDED MOVEMENT**

- Do not use DC injection to generate holding torque when the motor is at a standstill.
- Use a holding brake to keep the motor in the standstill position.

**Failure to follow these instructions can result in death, serious injury, or equipment damage.**

DC injection braking is initiated when the assigned input or bit changes to state 1.

If the input returns to state 0 and the run command is still active, the motor will only restart if **[2/3-wire control] E C C** is set to **[2-Wire Control] 2 C** and if **[2-wire type] E C E** is set to **[Level] L E L** or **[Fwd priority] P F a**. If not, a new run command must be sent.

**NOTE:** This function cannot be used with some other functions. Follow the instructions about the compatibility of functions.

Setting	Code / Value	Description
[Not Assigned]	n a	Not assigned <b>Factory setting</b>
[DI1]...[DI6]	L , I...L , B	Digital input DI1...DI6
[DI11]...[DI16]	L , I I...L , I B	Digital input DI11...DI16 if VW3A3203 I/O extension module has been inserted
[CD00]...[CD10]	C d 0 0...C d 1 0	Virtual digital input CMD.0...CMD.10 in <b>[I/O profile] , a</b> configuration
[CD11]...[CD15]	C d 1 1...C d 1 5	Virtual digital input CMD.11...CMD.15 regardless of configuration
[C100]...[C110]	C 1 0 0...C 1 1 0	Virtual digital input CMD1.0...CMD1.10 with integrated Modbus Serial in <b>[I/O profile] , a</b> configuration
[C111]...[C115]	C 1 1 1...C 1 1 5	Virtual digital input CMD1.11...CMD1.15 with integrated Modbus Serial regardless of configuration
[C200]...[C210]	C 2 0 0...C 2 1 0	Virtual digital input CMD2.0...CMD2.10 with CANopen® fieldbus module in <b>[I/O profile] , a</b> configuration
[C211]...[C215]	C 2 1 1...C 2 1 5	Virtual digital input CMD2.11...CMD2.15 with CANopen® fieldbus module regardless of configuration
[C300]...[C310]	C 3 0 0...C 3 1 0	Virtual digital input CMD3.0...CMD3.10 with a fieldbus module in <b>[I/O profile] , a</b> configuration
[C311]...[C315]	C 3 1 1...C 3 1 5	Virtual digital input CMD3.11...CMD3.15 with a fieldbus module regardless of configuration
[C500]...[C510]	C 5 0 0...C 5 1 0	Virtual digital input CMD5.0...CMD5.10 with integrated Ethernet Modbus TCP in <b>[I/O profile] , a</b> configuration
[C511]...[C515]	C 5 1 1...C 5 1 5	Virtual digital input CMD5.11...CMD5.15 with integrated Ethernet Modbus TCP regardless of configuration

**[DC inject. level 1]  $i_{dC1}$  ★**

DC injection current.

<b>NOTICE</b>
<p><b>OVERHEATING AND DAMAGE TO THE MOTOR</b></p> <p>Verify that the connected motor is properly rated for the DC injection current to be applied in terms of amount and time in order to avoid overheating and damage to the motor.</p> <p><b>Failure to follow these instructions can result in equipment damage.</b></p>

Level of DC injection braking current activated via digital input or selected as stop mode.

This parameter can be accessed if:

- [Type of stop]  $S_{tE}$  is set to [DC injection]  $dC_1$ , or
- [DC.Brake DI]  $dC_1$  is not set to [No]  $n0$ .

Setting ( )	Description
0.1...1.41 $I_n^{(1)}$	Setting range This setting is independent of the [Auto DC Injection] $R_{dC}$ - function. <b>Factory setting:</b> 0.64 $I_n^{(1)}$
(1) $I_n$ corresponds to the rated drive current indicated in the Installation Manual and on the drive nameplate.	

**[DC injection time 1]  $t_{dC1}$  ★**

DC injection time 1.

<b>NOTICE</b>
<p><b>OVERHEATING AND DAMAGE TO THE MOTOR</b></p> <p>Verify that the connected motor is properly rated for the DC injection current to be applied in terms of amount and time in order to avoid overheating and damage to the motor.</p> <p><b>Failure to follow these instructions can result in equipment damage.</b></p>

Maximum current injection time [DC inject. level 1]  $i_{dC1}$ . After this time, the injection current becomes [DC inject. level 2]  $i_{dC2}$ .

This parameter can be accessed if:

- [Type of stop]  $S_{tE}$  is set to [DC injection]  $dC_1$ , or
- [DC.Brake DI]  $dC_1$  is not set to [No]  $n0$ .

Setting ( )	Description
0.1...30 s	Setting range This setting is independent of the [Auto DC Injection] $R_{dC}$ - function. <b>Factory setting:</b> 0.5 s

**[DC inject. level 2]  $i_{dC2}$  ★**

DC injection current 2.

**NOTICE****OVERHEATING AND DAMAGE TO THE MOTOR**

Verify that the connected motor is properly rated for the DC injection current to be applied in terms of amount and time in order to avoid overheating and damage to the motor.

**Failure to follow these instructions can result in equipment damage.**

Injection current activated by digital input or selected as stop mode once period **[DC injection time 1]  $t_{dC1}$**  has elapsed.

This parameter can be accessed if:

- **[Type of stop]  $S_{tk}$**  is set to **[DC injection]  $dC1$** , or
- **[DC.Brake DI]  $dC1$**  is not set to **[No]  $n0$** .

Setting ( )	Description
0.1 In <sup>(1)</sup> ... <b>[DC inject. level 1] <math>i_{dC1}</math></b>	Setting range This setting is independent of the <b>[Auto DC Injection] <math>A_{dC}</math></b> - function. <b>Factory setting:</b> 0.5 In <sup>(1)</sup>
<b>(1)</b> In corresponds to the rated drive current indicated in the Installation Manual and on the drive nameplate.	

**[DC Inj Time 2]  $t_{dC2}$  ★**

2nd DC injection time.

**NOTICE****OVERHEATING AND DAMAGE TO THE MOTOR**

Verify that the connected motor is properly rated for the DC injection current to be applied in terms of amount and time in order to avoid overheating and damage to the motor.

**Failure to follow these instructions can result in equipment damage.**

Maximum injection time **[DC inject. level 2]  $i_{dC2}$**  for injection, selected as stop mode only.

This parameter can be accessed if **[Type of stop]  $S_{tk}$**  is set to **[DC injection]  $dC1$** .

Setting ( )	Description
0.1...30 s	Setting range This setting is independent of the <b>[Auto DC Injection] <math>A_{dC}</math></b> - function. <b>Factory setting:</b> 0.5 s

**[SwitchOnDisable Stp]  $d0td$** 

Disable operation stop mode.

Setting	Code / Value	Description
<b>[Freewheel Stop]</b>	$n5t$	Disable drive function
<b>[Ramp Stop]</b>	$rPP$	Ramp stop then disable drive function <b>Factory setting</b>

## Section 7.36

### [Generic functions] - [Auto DC injection]

#### [Auto DC injection] *A d C* - Menu

##### Access

[Complete settings] → [Generic functions] → [Auto DC injection]

##### About This Menu

This menu presents the automatic injection of motor current function. This is used to hold the rotor of the motor at the end of the deceleration ramp.

#### [Auto DC Injection] *A d C*

Automatic DC Injection.

### DANGER

#### HAZARD OF ELECTRIC SHOCK, EXPLOSION, OR ARC FLASH

If the parameter [Auto DC Injection] *A d C* is set to [Continuous] *C L*, DC injection is always active, even if the motor does not run.

- Verify that using this setting does not result in unsafe conditions.

**Failure to follow these instructions will result in death or serious injury.**

### WARNING

#### UNINTENDED MOVEMENT

- Do not use DC injection to generate holding torque when the motor is at a standstill.
- Use a holding brake to keep the motor in the standstill position.

**Failure to follow these instructions can result in death, serious injury, or equipment damage.**

Automatic current injection on stopping (at the end of the ramp).

**NOTE:** There is an interlock between this function and [Motor fluxing] *F L u*. If [Motor fluxing] *F L u* is set to [Continuous] *F C L*, [Auto DC Injection] *A d C* must be [No] *n o*.

[Auto DC Injection] *A d C* is forced to [No] *n o* when [Brake assignment] *b L C* is not set to [No] *n o*. This parameter gives rise to the injection of current even if a run command has not been sent.

Setting 	Code / Value	Description
[No]	<i>n o</i>	No injection
[Yes]	<i>Y E 5</i>	Adjustable injection time <b>Factory setting</b>
[Continuous]	<i>C L</i>	Continuous standstill injection

**[Auto DC inj Level 1] 5 d C 1 ★**

Auto DC injection level 1.

**NOTICE****OVERHEATING AND DAMAGE TO THE MOTOR**

Verify that the connected motor is properly rated for the DC injection current to be applied in terms of amount and time in order to avoid overheating and damage to the motor.

**Failure to follow these instructions can result in equipment damage.**

Level of standstill DC injection current **[Auto DC Injection] R d C** is not **[No] n o**.

Setting ( )	Description
0...1.2 In <sup>(1)</sup>	Setting range <b>Factory setting:</b> 0.7 In <sup>(1)</sup>
<b>(1)</b> In corresponds to the rated drive current indicated in the Installation Manual and on the drive nameplate.	

**[Auto DC Inj Time 1] E d C 1 ★**

Auto DC injection time 1.

**NOTICE****OVERHEATING AND DAMAGE TO THE MOTOR**

Verify that the connected motor is properly rated for the DC injection current to be applied in terms of amount and time in order to avoid overheating and damage to the motor.

**Failure to follow these instructions can result in equipment damage.**

This parameter can be accessed if **[Auto DC Injection] R d C** is not set to **[No] n o**.

If **[Motor control type] C E E** is set to **[SYN\_U VC] 5 Y n u**, this time corresponds to the zero speed maintenance time.

Setting ( )	Description
0.1...30.0 s	Setting range <b>Factory setting:</b> 0.5 s

**[Auto DC inj Level 2] 5 d C 2 ★**

Auto DC injection level 2.

**NOTICE****OVERHEATING AND DAMAGE TO THE MOTOR**

Verify that the connected motor is properly rated for the DC injection current to be applied in terms of amount and time in order to avoid overheating and damage to the motor.

**Failure to follow these instructions can result in equipment damage.**

Second level of standstill DC injection current.

This parameter can be accessed if **[Auto DC Injection] R d C** is not set to **[No] n o**.

Setting ( )	Description
0...1.2 In <sup>(1)</sup>	Setting range <b>Factory setting:</b> 0.5 In <sup>(1)</sup>
<b>(1)</b> In corresponds to the rated drive current indicated in the Installation Manual and on the drive nameplate.	

[Auto DC Inj Time 2] *E d C 2* ★

Auto DC injection time 2.

**NOTICE**

**OVERHEATING AND DAMAGE TO THE MOTOR**

Verify that the connected motor is properly rated for the DC injection current to be applied in terms of amount and time in order to avoid overheating and damage to the motor.

**Failure to follow these instructions can result in equipment damage.**

Second standstill injection time.

This parameter can be accessed if [Auto DC Injection] *R d C* is set to [YES] *Y E 5*.

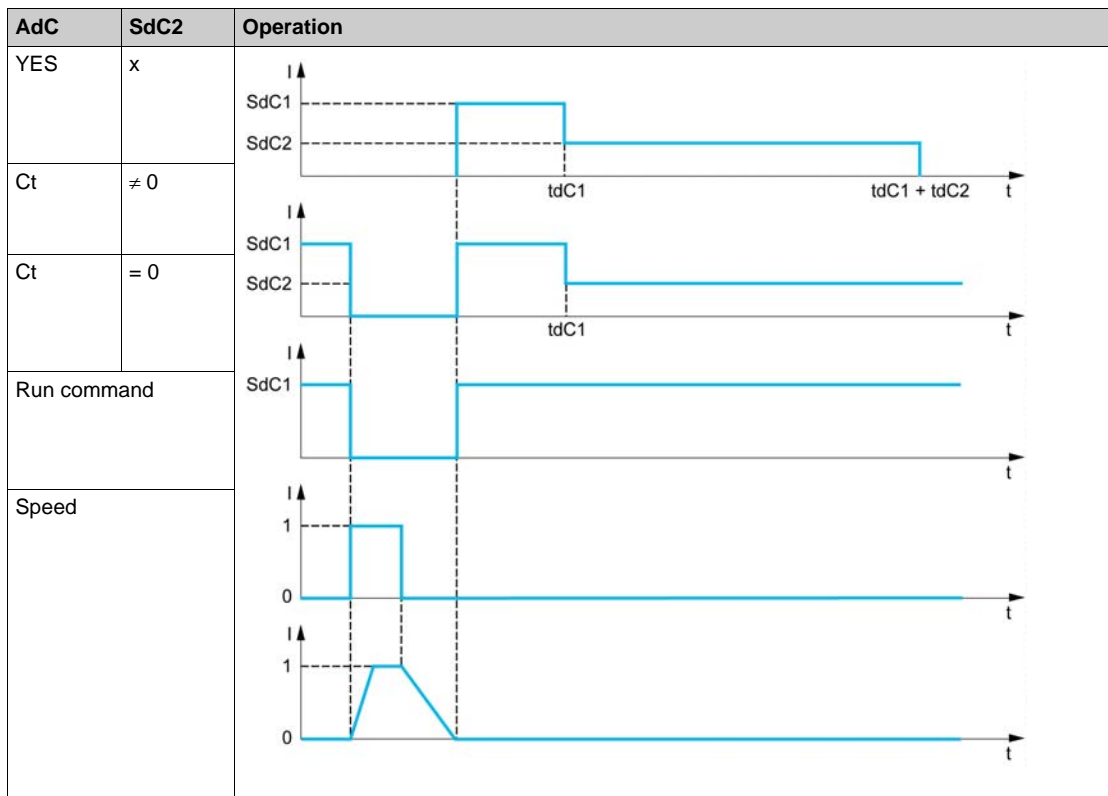

Setting ( )	Description
0.0...30.0 s	Setting range Factory setting: 0.0 s

## Section 7.37

### [Generic functions] - [Ref. operations]

#### [Ref. operations] $\square$ $\Pi$ - Menu

##### Access

[Complete settings]  $\rightarrow$  [Generic functions]  $\rightarrow$  [Ref. operations]

##### About This Menu

Summing input / subtraction input / multiplier

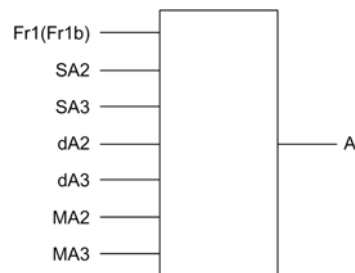

$$A = (Fr1 \text{ or } Fr1b + SA2 + SA3 - dA2 - dA3) \times MA2 \times MA3$$

##### NOTE:

- If  $SA2$ ,  $SA3$ ,  $dA2$ ,  $dA3$  are not assigned, they are set to 0.
- If  $MA2$ ,  $MA3$  are not assigned, they are set to 1.
- A is limited by the minimum  $LSP$  and maximum  $HSP$  parameters.
- For a multiplication, the signal on  $MA2$  or  $MA3$  is interpreted as a %. 100% corresponds to the maximum value of the corresponding input. If  $MA2$  or  $MA3$  is sent via the communication bus or Graphic Display Terminal, an  $PFr$  multiplication variable must be sent via the bus or Graphic Display Terminal.
- Reversal of the direction of operation in the event of a negative result can be blocked (see [Reverse Disable]  $r_{in}$ ).

#### [Summing Input 2] $SA2$

Summing input 2.

Selection of a reference to be added to [Ref Freq 1 Config]  $Fr1$  or [Ref.1B channel]  $Fr1b$ .

Setting	Code / Value	Description
[Not Configured]	$no$	Not assigned
[AI1]	$A_{i1}$	Analog input AI1 <b>Factory Setting</b>
[AI2]...[AI3]	$A_{i2}...A_{i3}$	Analog input AI2...AI3
[AI4]...[AI5]	$A_{i4}...A_{i5}$	Analog input AI4...AI5 if VW3A3203 I/O extension module has been inserted
[Ref Frequency via DI]	$uPdt$	Up/Down function is assigned by DIx
[Ref. Freq-Modbus]	$\Pi db$	Reference frequency via Modbus
[Ref. Freq-CANopen]	$CAn$	Reference frequency via CANopen if a CANopen module has been inserted
[Ref. Freq-Com. Module]	$nEt$	Reference frequency via fieldbus module if a fieldbus module has been inserted
[Embedded Ethernet]	$EtH$	Embedded Ethernet
[PulseInput Assignment On DI5]...[PulseInput Assignment On DI6]	$P_{i5}...P_{i6}$	Digital input DI5...DI6 used as pulse input

**[Summing Input 3] 5 A 3**

Summing input 3.

Selection of a reference to be added to **[Ref Freq 1 Config] F r 1** or **[Ref.1B channel] F r 1 b**.

Identical to **[Summing Input 2] 5 A 2**

**[Subtract Ref Freq 2] 4 A 2**

Subtract reference frequency 2.

Selection of a reference to be subtracted from **[Ref Freq 1 Config] F r 1** or **[Ref.1B channel] F r 1 b**.

Identical to **[Summing Input 2] 5 A 2**

**[Subtract Ref Freq 3] 4 A 3**

Subtract reference frequency 3 (in % of the source range).

Selection of a reference to be subtracted from **[Ref Freq 1 Config] F r 1** or **[Ref.1B channel] F r 1 b**.

Identical to **[Summing Input 2] 5 A 2**.

**[Ref Freq 2 Multiply] 7 A 2**

Reference frequency 2 multiply (in % of the source range).

Selection of a multiplier reference **[Ref Freq 1 Config] F r 1** or **[Ref.1B channel] F r 1 b**.

Identical to **[Summing Input 2] 5 A 2**.

**[Ref Freq 3 Multiply] 7 A 3**

Reference frequency 3 multiply.

Selection of a multiplier reference **[Ref Freq 1 Config] F r 1** or **[Ref.1B channel] F r 1 b**.

Identical to **[Summing Input 2] 5 A 2**.



## Section 7.38

### [Generic functions] - [Preset speeds]

#### [Preset speeds] P 5 5 - Menu

##### Access

[Complete settings] → [Generic functions] → [Preset speeds]

##### About This Menu

**NOTE:** This function cannot be used with some other functions. Follow the instructions about the compatibility of functions.

##### Combination Table for Preset Speed Inputs

2, 4, 8 or 16 speeds can be preset, requiring 1, 2, 3 or 4 digital inputs respectively.

It is necessary to configure:

- 2 and 4 speeds in order to obtain 4 speeds.
- 2, 4 and 8 speeds in order to obtain 8 speeds.
- 2, 4, 8 and 16 speeds in order to obtain 16 speeds.

16 Preset Freq (PS16)	8 Preset Freq (PS8)	4 Preset Freq (PS4)	2 Preset Freq (PS2)	Speed Reference
0	0	0	0	Reference 1 <sup>(1)</sup>
0	0	0	1	SP2
0	0	1	0	SP3
0	0	1	1	SP4
0	1	0	0	SP5
0	1	0	1	SP6
0	1	1	0	SP7
0	1	1	1	SP8
1	0	0	0	SP9
1	0	0	1	SP10
1	0	1	0	SP11
1	0	1	1	SP12
1	1	0	0	SP13
1	1	0	1	SP14
1	1	1	0	SP15
1	1	1	1	SP16

(1) Reference 1 = 5 P I, refer to diagram (see page 251)

**[2 Preset Freq] P 5 2**

2 preset freq assignment.

Setting	Code / Value	Description
[Not Assigned]	n a	Not assigned <b>Factory setting</b>
[DI1]...[DI6]	L , I ... L , I 6	Digital input DI1...DI6
[DI11]...[DI16]	L , I I I ... L , I 6	Digital input DI11...DI16 if VW3A3203 I/O extension module has been inserted
[CD00]...[CD10]	C d 0 0 ... C d 1 0	Virtual digital input CMD.0...CMD.10 in <b>[I/O profile]</b> , a configuration
[CD11]...[CD15]	C d 1 1 ... C d 1 5	Virtual digital input CMD.11...CMD.15 regardless of configuration
[C100]...[C110]	C 1 0 0 ... C 1 1 0	Virtual digital input CMD1.0...CMD1.10 with integrated Modbus Serial in <b>[I/O profile]</b> , a configuration
[C111]...[C115]	C 1 1 1 ... C 1 1 5	Virtual digital input CMD1.11...CMD1.15 with integrated Modbus Serial regardless of configuration
[C200]...[C210]	C 2 0 0 ... C 2 1 0	Virtual digital input CMD2.0...CMD2.10 with CANopen® fieldbus module in <b>[I/O profile]</b> , a configuration
[C211]...[C215]	C 2 1 1 ... C 2 1 5	Virtual digital input CMD2.11...CMD2.15 with CANopen® fieldbus module regardless of configuration
[C300]...[C310]	C 3 0 0 ... C 3 1 0	Virtual digital input CMD3.0...CMD3.10 with a fieldbus module in <b>[I/O profile]</b> , a configuration
[C311]...[C315]	C 3 1 1 ... C 3 1 5	Virtual digital input CMD3.11...CMD3.15 with a fieldbus module regardless of configuration
[C500]...[C510]	C 5 0 0 ... C 5 1 0	Virtual digital input CMD5.0...CMD5.10 with integrated Ethernet Modbus TCP in <b>[I/O profile]</b> , a configuration
[C511]...[C515]	C 5 1 1 ... C 5 1 5	Virtual digital input CMD5.11...CMD5.15 with integrated Ethernet Modbus TCP regardless of configuration

**[4 Preset Freq] P 5 4**

4 preset freq assignment.

Identical to **[2 Preset Freq] P 5 2**

To obtain 4 speeds, you must also configure 2 speeds.

**[8 Preset Freq] P 5 B**

8 preset freq assignment.

Identical to **[2 Preset Freq] P 5 2**

To obtain 8 speeds, you must also configure 2 and 4 speeds.

**[16 Preset Freq] P 5 16**

16 preset freq assignment.

Identical to **[2 Preset Freq] P 5 2**

To obtain 8 speeds, you must also configure 2 and 4 speeds.

**[Preset speed 2] 5 P 2 ★**

Preset speed 2. See the combination table for preset speed inputs ([see page 553](#)).

Setting ( )	Description
0.0...500.0 Hz	Setting range <b>Factory setting:</b> 10.0 Hz

**[Preset speed 3] 5 P 3 ★**

Preset speed 3. See the combination table for preset speed inputs ([see page 553](#)).

Setting ( )	Description
0.0...500.0 Hz	Setting range <b>Factory setting:</b> 15.0 Hz

**[Preset speed 4] 5 P 4 ★**

Preset speed 4. See the combination table for preset speed inputs ([see page 553](#)).

Setting ( )	Description
0.0...500.0 Hz	Setting range <b>Factory setting:</b> 20.0 Hz

**[Preset speed 5] 5 P 5 ★**

Preset speed 5. See the combination table for preset speed inputs ([see page 553](#)).

Setting ( )	Description
0.0...500.0 Hz	Setting range <b>Factory setting:</b> 25.0 Hz

**[Preset speed 6] 5 P 6 ★**

Preset speed 6. See the combination table for preset speed inputs ([see page 553](#)).

Setting ( )	Description
0.0...500.0 Hz	Setting range <b>Factory setting:</b> 30.0 Hz

**[Preset speed 7] 5 P 7 ★**

Preset speed 7. See the combination table for preset speed inputs ([see page 553](#)).

Setting ( )	Description
0.0...500.0 Hz	Setting range <b>Factory setting:</b> 35.0 Hz

**[Preset speed 8] 5 P 8 ★**

Preset speed 8. See the combination table for preset speed inputs ([see page 553](#)).

Setting ( )	Description
0.0...500.0 Hz	Setting range <b>Factory setting:</b> 40.0 Hz

**[Preset speed 9] 5 P 9 ★**

Preset speed 9. See the combination table for preset speed inputs ([see page 553](#)).

Setting ( )	Description
0.0...500.0 Hz	Setting range <b>Factory setting:</b> 45.0 Hz

**[Preset speed 10] 5 P 10 ★**

Preset speed 10. See the combination table for preset speed inputs ([see page 553](#)).

Setting ( )	Description
0.0...500.0 Hz	Setting range <b>Factory setting:</b> 50.0 Hz

**[Preset speed 11] 5 P 11 ★**

Preset speed 11. See the combination table for preset speed inputs ([see page 553](#)).

Setting ( )	Description
0.0...500.0 Hz	Setting range <b>Factory setting:</b> 55.0 Hz

**[Preset speed 12] 5 P 12 ★**

Preset speed 12. See the combination table for preset speed inputs ([see page 553](#)).

Setting ( )	Description
0.0...500.0 Hz	Setting range <b>Factory setting:</b> 60.0 Hz

**[Preset speed 13] 5 P 13 ★**

Preset speed 13. See the combination table for preset speed inputs ([see page 553](#)).

Setting ( )	Description
0.0...500.0 Hz	Setting range <b>Factory setting:</b> 70.0 Hz

**[Preset speed 14] 5 P 14 ★**

Preset speed 14. See the combination table for preset speed inputs ([see page 553](#)).

Setting ( )	Description
0.0...500.0 Hz	Setting range <b>Factory setting:</b> 80.0 Hz

**[Preset speed 15] 5 P 15 ★**

Preset speed 15 See the combination table for preset speed inputs ([see page 553](#)).

Setting ( )	Description
0.0...500.0 Hz	Setting range <b>Factory setting:</b> 90.0 Hz

**[Preset speed 16] 5 P 16 ★**

Preset speed 16. See the combination table for preset speed inputs ([see page 553](#)).

Setting ( )	Description
0.0...500.0 Hz	Setting range <b>Factory setting:</b> 100.0 Hz

## Section 7.39

### [Generic functions] - [+/- speed]

#### [+/- speed] $\cup$ P d - Menu

##### Access

[Complete settings] → [Generic functions] → [+/- speed]

##### About This Menu

This function can be accessed if reference channel [Ref Freq 2 Config]  $F r 2$  is set to [Ref Frequency via DI]  $\cup$  P d t

**NOTE:** This function cannot be used with some other functions. Follow the instructions about the compatibility of functions.

2 types of operations are available:

- **Use of single action keys:** 2 digital inputs are required in addition to the operating directions. The input assigned to the “+ speed” command increases the speed, the input assigned to the “– speed” command decreases the speed.
- **Use of double action keys:** Only one digital input assigned to “+ speed” is required.

+/- speed with double-press buttons:

Description: 1 button pressed twice (2 steps) for each direction of rotation. A contact closes each time the button is pressed.

Setting	Released (– Speed)	First Press (Speed Maintained)	Second Press (Faster)
Forward button	–	a	a and b
Reverse button	–	c	c and d

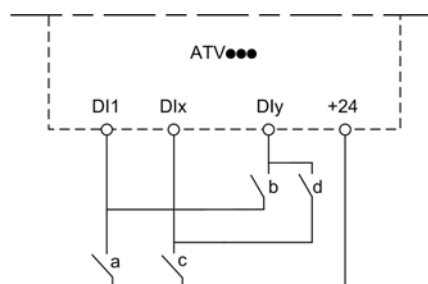

DI1 Forward  
DIx Reverse  
DIy + speed

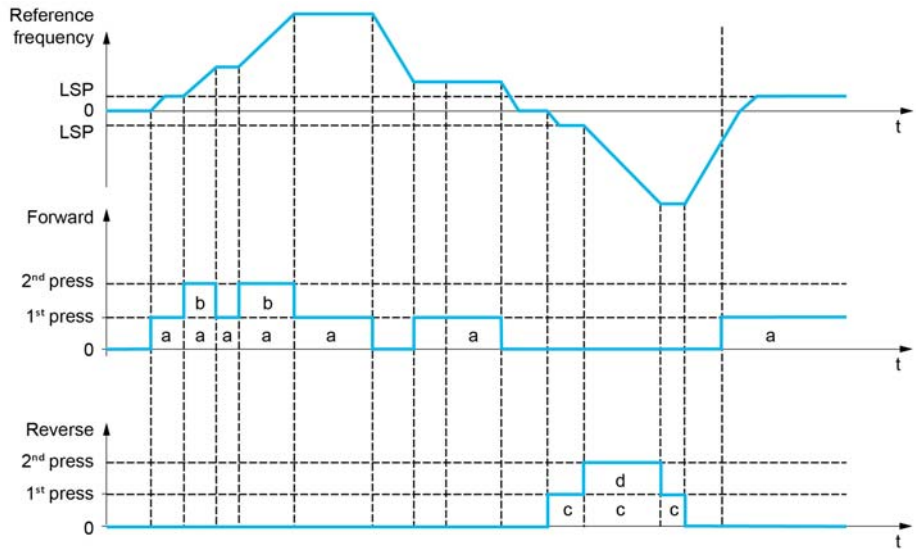

Do not use this +/- speed type with a 3-wire control.

Whichever type of operation is selected, the max. speed is set by **[High speed] H 5 P**.

**NOTE:** If the reference is switched via **[Freq Switch Assign] r F C** from any reference channel to another reference channel with "+/- speed", the value of reference **[Motor Frequency] r F r** (after ramp) may be copied at the same time in accordance with the **[Copy Ch1-Ch2] C o P** parameter.

If the reference is switched via **[Freq Switch Assign] r F C** from one reference channel to any other reference channel with "+/- speed", the value of reference **[Motor Frequency] r F r** (after ramp) is copied at the same time.

This helps to prevent the speed from being incorrectly reset to zero when switching takes place.

**[+ Speed Assign] u 5 P**

Increase speed input assignment.

Function active if the assigned input or bit is at 1.

Setting	Code / Value	Description
<b>[Not Assigned]</b>	<b>n o</b>	Not assigned <b>Factory setting</b>
<b>[DI1]...[DI6]</b>	<b>L , I ... L , 6</b>	Digital input DI1...DI6
<b>[DI11]...[DI16]</b>	<b>L , I I ... L , 16</b>	Digital input DI11...DI16 if VW3A3203 I/O extension module has been inserted
<b>[CD00]...[CD10]</b>	<b>C d 0 0 ... C d 1 0</b>	Virtual digital input CMD.0...CMD.10 in <b>[I/O profile] , o</b> configuration
<b>[CD11]...[CD15]</b>	<b>C d 1 1 ... C d 1 5</b>	Virtual digital input CMD.11...CMD.15 regardless of configuration
<b>[C100]...[C110]</b>	<b>C 1 0 0 ... C 1 1 0</b>	Virtual digital input CMD1.0...CMD1.10 with integrated Modbus Serial in <b>[I/O profile] , o</b> configuration
<b>[C111]...[C115]</b>	<b>C 1 1 1 ... C 1 1 5</b>	Virtual digital input CMD1.11...CMD1.15 with integrated Modbus Serial regardless of configuration
<b>[C200]...[C210]</b>	<b>C 2 0 0 ... C 2 1 0</b>	Virtual digital input CMD2.0...CMD2.10 with CANopen® fieldbus module in <b>[I/O profile] , o</b> configuration
<b>[C211]...[C215]</b>	<b>C 2 1 1 ... C 2 1 5</b>	Virtual digital input CMD2.11...CMD2.15 with CANopen® fieldbus module regardless of configuration
<b>[C300]...[C310]</b>	<b>C 3 0 0 ... C 3 1 0</b>	Virtual digital input CMD3.0...CMD3.10 with a fieldbus module in <b>[I/O profile] , o</b> configuration
<b>[C311]...[C315]</b>	<b>C 3 1 1 ... C 3 1 5</b>	Virtual digital input CMD3.11...CMD3.15 with a fieldbus module regardless of configuration
<b>[C500]...[C510]</b>	<b>C 5 0 0 ... C 5 1 0</b>	Virtual digital input CMD5.0...CMD5.10 with integrated Ethernet ModbusTCP in <b>[I/O profile] , o</b> configuration
<b>[C511]...[C515]</b>	<b>C 5 1 1 ... C 5 1 5</b>	Virtual digital input CMD5.11...CMD5.15 with integrated Ethernet ModbusTCP regardless of configuration

**[- Speed Assign] d 5 P**

Down speed input assignment. See the assignment conditions.

Parameter settings identical to **[+ Speed Assign] u 5 P**.

Function active if the assigned input or bit is at 1.

**[Ref Frequency Save] 5 t r ★**

Reference frequency saves. This parameter can be accessed if **[+ Speed Assign] u 5 P** is not set to **[Not Assigned] n o**.

Associated with the "+/- speed" function, this parameter can be used to save the reference:

- When the run commands disappear (saved to RAM).
- When the supply mains or the run commands disappear (saved to EEPROM).

Therefore, next time the drive starts up, the speed reference is the last reference frequency saved.

Setting	Code / Value	Description
<b>[No save]</b>	<i>n o</i>	Not saved <b>Factory setting</b>
<b>[Save to RAM]</b>	<i>r A M</i>	+/- speed with saving of the reference frequency in RAM
<b>[Save to EEprom]</b>	<i>E E P</i>	+/- speed with saving of the reference frequency in EEPROM

## Section 7.40

### [Generic functions] - [Jump frequency]

---

#### [Jump frequency] JUF - Menu

##### Access

[Complete settings] → [Generic functions] → [Jump frequency]

##### About This Menu

Identical to [Jump frequency] JUF - Menu (*see page 531*).



---

## Section 7.41

### [Generic functions] - [PID controller]

---

#### What Is in This Section?

This section contains the following topics:

Topic	Page
[PID controller] $P, I, D$ - Overview	562
[Feedback] $F, d, b$ - Menu	565
[Reference frequency] $r, F$ - Menu	571
[PID preset references] $P, r, i$ - Menu	574
[Reference frequency] $r, F$ - Menu	576
[Settings] $S, E$ - Menu	577

## [PID controller] P, d - Overview

### About This Menu

**NOTE:** This function cannot be used with some other functions. Follow the instructions about the compatibility of functions.

### Block Diagram

The function is activated by assigning an analog input to the PID feedback (measurement).

The PID feedback needs to be assigned to one of the analog inputs AI1 to AI5 or a pulse input, according to whether any I/O extension module has been inserted.

The PID reference needs to be assigned to the following parameters:

- Preset references via digital inputs ([Ref PID Preset 2] r P 2, [Ref PID Preset 3] r P 3, [Ref PID Preset 4] r P 4).
- In accordance with the configuration of [Intern PID Ref] P, i:
  - [Internal PID ref] r P, i, or
  - Reference A [Ref Freq 1 Config] F r 1 or [Ref.1B channel] F r 1 b.

### Combination Table for Preset PID References:

DI (P r 4)	DI (P r 2)	P r 2 = n o	Reference
			r P, i or F r 1 ( b)
0	0		r P, i or F r 1 ( b)
0	1		r P 2
1	0		r P 3
1	1		r P 4

A predictive speed reference can be used to initialize the speed on restarting the process.

Scaling of feedback and references:

- [Min PID feedback] P, F 1, [Max PID feedback] P, F 2 parameters can be used to scale the PID feedback (sensor range). **This scale MUST be maintained for all other parameters.**
- [Min PID Process] P, P 1, [Max PID Process] P, P 2 parameters can be used to scale the adjustment range, for example the reference. **Check that the adjustment range remains within the sensor range.**

The maximum value of the scaling parameters is 32,767. To facilitate the installation, it is recommended to use values as close as possible to this maximum level, while retaining powers of 10 in relation to the actual values. The scaling is without unit if [Type of control] E o C E is set to [NA] n A, in % if set to [OTHER] o E H E r, in process unit if set to [PRESSURE] P r E 5 5 or [FLOW] F L o W.

### Example

Adjustment of the volume in a tank, 6...15 m<sup>3</sup>.

- Probe used 4-20 mA, 4.5 m<sup>3</sup> for 4 mA and 20 m<sup>3</sup> for 20 mA, with the result that P, F 1 = 4,500 and P, F 2 = 20,000.
- Adjustment range 6 to 15 m<sup>3</sup>, with the result that P, P 1 = 6,000 (min. reference) and P, P 2 = 15,000 (max. reference).
- Example references:
  - r P 1 (internal reference) = 9,500
  - r P 2 (preset reference) = 6,500
  - r P 3 (preset reference) = 8,000
  - r P 4 (preset reference) = 11,200

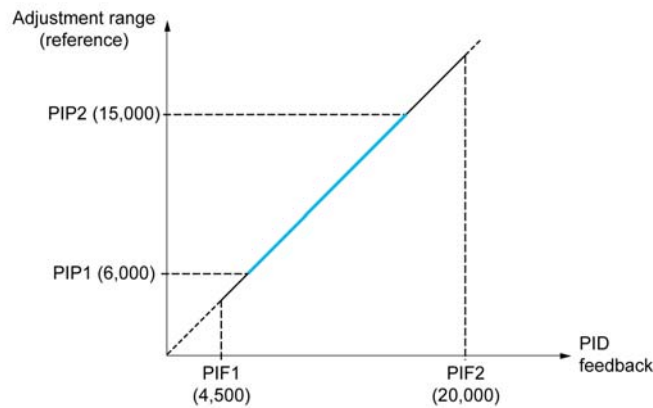

Other parameters:

- Reversal of the direction of correction **[PID Inversion] P, C**. If **[PID Inversion] P, C** is set to **[No] n o**, the speed of the motor increases when the detected error is positive (for example pressure control with a compressor). If **[PID Inversion] P, C** is set to **[Yes] y e s**, the speed of the motor decreases when the detected error is positive (for example temperature control using a cooling fan).
- The integral gain may be short-circuited by a digital input.
- A warning on the **[PID feedback] P, F** may be configured.
- A warning on the **[PID error] r P E** may be configured.

### "Manual - Automatic" Operation with PID

This function combines the PID controller, the preset speeds, and a manual reference. Depending on the state of the digital input, the speed reference is given by the preset speeds or by a manual reference input via the PID function.

Manual PID reference **[Manual PID reference] P, P**:

- Analog inputs AI1 to AI5
- Pulse inputs

Predictive speed reference **[Predictive Speed Ref] F P**:

- **[AI1] A, 1**: analog input
- **[AI2] A, 2**: analog input
- **[AI3] A, 3**: analog input
- **[AI4] A, 4**: analog input
- **[AI5] A, 5**: analog input
- **[DI5 PulseInput Assignment] P, 5**: pulse input
- **[DI6 PulseInput Assignment] P, 6**: pulse input
- **[Ref.Freq-Rmt.Term] L C C**: Graphic Display Terminal
- **[Modbus] M d b**: integrated Modbus
- **[CANopen] C A n**: CANopen®
- **[Com. Module] n E t**: fieldbus option module (if inserted)
- **[Embedded Ethernet] E t H**: integrated Ethernet Modbus TCP

### Setting Up the PID controller

#### 1. Configuration in PID mode.

Refer to the Block Diagram ([see page 562](#)).

#### 2. Perform a test in factory settings mode.

To optimize the drive, adjust **[PID Prop.Gain] r P G** or **[PID Intgl.Gain] r, G** gradually and independently, and observe the effect on the PID feedback in relation to the reference.

#### 3. If the factory settings are unstable or the reference is incorrect.

Step	Action
1	Perform a test with a speed reference in Manual mode (without PID controller) and with the drive on load for the speed range of the system: <ul style="list-style-type: none"> <li>• In steady state, the speed must be stable and comply with the reference, and the PID feedback signal must be stable.</li> <li>• In transient state, the speed must follow the ramp and stabilize quickly, and the PID feedback must follow the speed. If not, see the settings for the drive and/or sensor signal and wiring.</li> </ul>
2	Switch to PID mode.
3	Set <b>[PID ramp] <math>P_r P</math></b> to the minimum permitted by the mechanism without triggering an <b>[DC Bus Overvoltage] <math>o b F</math></b> .
4	Set the integral gain <b>[PID Intgl.Gain] <math>r_i G</math></b> to minimum.
5	Leave the derivative gain <b>[PID derivative gain] <math>r_d G</math></b> at 0.
6	Observe the PID feedback and the reference.
7	Switch the drive ON/OFF a number of times or vary the load or reference rapidly a number of times.
8	Set the proportional gain <b>[PID Prop.Gain] <math>r_P G</math></b> in order to ascertain the compromise between response time and stability in transient phases (slight overshoot and 1 to 2 oscillations before stabilizing).
9	If the reference varies from the preset value in steady state, gradually increase the integral gain <b>[PID Intgl.Gain] <math>r_i G</math></b> , reduce the proportional gain <b>[PID Prop.Gain] <math>r_P G</math></b> in the event of instability (pump applications), find a compromise between response time and static precision (see diagram).
10	Lastly, the derivative gain may permit the overshoot to be reduced and the response time to be improved, although this is more difficult to obtain a compromise in terms of stability, as it depends on 3 gains.
11	Perform in-production tests over the whole reference range.

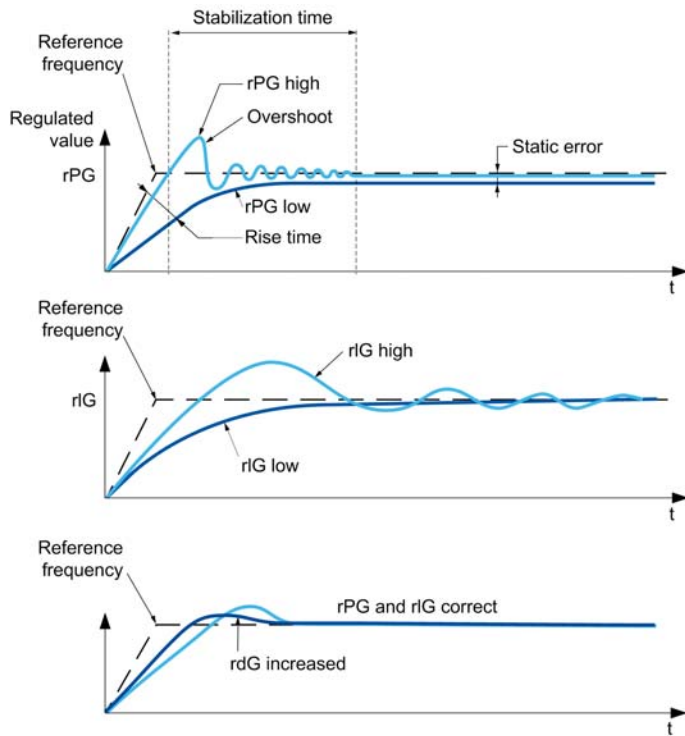

The oscillation frequency depends on the system kinematics:

Parameter	Rise time	Overshoot	Stabilization time	Static Error
rPG +	- -	+	=	-
rIG +	-	++	+	- -
rdG +	=	-	-	=

## [Feedback] *F d b* - Menu

### Access

[Complete settings] → [Generic functions] → [PID controller] → [Feedback]

### About This Menu

**NOTE:** This function cannot be used with some other functions. Follow the instructions about the compatibility of functions.

### [Type of Control] *t o c t*

Type of control for the PID = unit choice.

Setting	Code / Value	Description
[nA]	<i>n A</i>	Nothing special <b>Factory setting</b>
[Pressure]	<i>P r E S S</i>	Pressure control and unit
[Flow]	<i>F L o w</i>	Flow control and unit
[Other]	<i>o t h e r</i>	Other control and unit

### [PID Feedback] *P , F*

PID controller feedback.

Setting	Code / Value	Description
[No]	<i>n o</i>	Not assigned <b>Factory setting</b>
[AI1]...[AI3]	<i>A , 1...A , 3</i>	Analog input AI1...AI3
[AI4]...[AI5]	<i>A , 4...A , 5</i>	Analog input AI4...AI5 if VW3A3203 I/O extension module has been inserted
[AI Virtual 1]	<i>A , v 1</i>	Virtual analogic input 1
[PulseInput Assignment On DI5]...[PulseInput Assignment On DI6]	<i>P , 5...P , 6</i>	Digital input DI5...DI6 used as pulse input

### [AI1 Type] *A , I t* ★

Configuration of analog input AI1.

This parameter can be accessed if [PID Feedback] *P , F* is set to [AI1] *A , I*.

Setting	Code / Value	Description
[Voltage]	<i>V o l t</i>	0-10 Vdc <b>Factory setting</b>
[Current]	<i>C u r</i>	0-20 mA

### [AI1 min value] *v , L I* ★

AI1 voltage scaling parameter of 0%.

This parameter can be accessed if:

- [PID Feedback] *P , F* is set to [AI1] *A , I*, and
- [AI1 Type] *A , I t* is not set to [Voltage] *V o l t*.

Setting	Description
0.0...10.0 Vdc	Setting range <b>Factory setting:</b> 0.0 Vdc

**[AI1 max value]  $\cup, H, I$  ★**

AI1 voltage scaling parameter of 100%.

This parameter can be accessed if:

- **[PID Feedback]  $P, F$**  is set to **[AI1]  $R, I$** , and
- **[AI1 Type]  $R, I, E$**  is not set to **[Voltage]  $ID \cup$** .

Setting	Description
0.0...10.0 Vdc	Setting range <b>Factory setting:</b> 10.0 Vdc

**[AI1 min. value]  $C, L, I$  ★**

AI1 current scaling parameter of 0%.

This parameter can be accessed if:

- **[PID Feedback]  $P, F$**  is set to **[AI1]  $R, I$** , and
- **[AI1 Type]  $R, I, E$**  is not set to **[Current]  $DR$** .

Setting	Description
0.0...20.0 mA	Setting range <b>Factory setting:</b> 0.0 mA

**[AI1 max. value]  $C, H, I$  ★**

AI1 current scaling parameter of 100%.

This parameter can be accessed if:

- **[PID Feedback]  $P, F$**  is set to **[AI1]  $R, I$** , and
- **[AI Type]  $R, I, E$**  is not set to **[Current]  $DR$** .

Setting	Description
0.0...20.0 mA	Setting range <b>Factory setting:</b> 20.0 mA

**[AI2 Type]  $R, I, 2, E$  ★**

Configuration of analog input AI2.

This parameter can be accessed if **[PID Feedback]  $P, F$**  is set to **[AI2]  $R, I, 2$**

Setting	Code / Value	Description
<b>[Voltage]</b>	$ID \cup$	0-10 Vdc <b>Factory setting</b>
<b>[Current]</b>	$DR$	0-20 mA
<b>[PTC Management]</b>	$P, E, C$	1 to 6 PTC (in serial)
<b>[KTY]</b>	$K, E, Y$	1 KTY84
<b>[PT1000]</b>	$I, P, E, 3$	1 PT1000 connected with 2 wires
<b>[PT100]</b>	$I, P, E, 2$	1 PT100 connected with 2 wires
<b>[Water Prob]</b>	$L, E, \cup, E, L$	Water level
<b>[3PT1000]</b>	$3, P, E, 3$	3 PT1000 connected with 2 wires
<b>[3PT100]</b>	$3, P, E, 2$	3 PT100 connected with 2 wires

**[AI2 min value]  $\cup, L, 2$  ★**

AI2 voltage scaling parameter of 0%.

This parameter can be accessed if:

- **[PID Feedback]  $P, F$**  is set to **[AI2]  $R, I, 2$** , and
- **[AI2 Type]  $R, I, 2, E$**  is not set to **[Voltage]  $ID \cup$** .

Identical to **[AI1 min value]  $\cup, L, I$**  (see page 565).

**[AI2 max value] U, H 2 ★**

AI2 voltage scaling parameter of 100%.

This parameter can be accessed if:

- **[PID Feedback] P, F** is set to **[AI2] R, 2**, and
- **[AI2 Type] R, 2 E** is not set to **[Voltage] I 0 U**.

Identical to **[AI1 max value] U, H 1** (see page 566).

**[AI2 min. value] C, L 2 ★**

AI2 current scaling parameter of 0%.

This parameter can be accessed if:

- **[PID Feedback] P, F** is set to **[AI2] R, 2**, and
- **[AI2 Type] R, 2 E** is not set to **[Current] 0 R**.

Identical to **[AI1 min. value] C, L 1** (see page 566).

**[AI2 max. value] C, H 2 ★**

AI2 current scaling parameter of 100%.

This parameter can be accessed if:

- **[PID Feedback] P, F** is set to **[AI2] R, 2**, and
- **[AI2 Type] R, 2 E** is not set to **[Current] 0 R**.

Identical to **[AI1 max. value] C, H 1** (see page 566).

**[AI3 Type] R, 3 E ★**

Configuration of analog input AI3.

This parameter can be accessed if **[PID Feedback] P, F** is set to **[AI3] R, 3**.

Identical to **[AI2 Type] R, 2 E** (see page 566) with factory setting: **[Current] 0 R**.

**[AI3 min value] U, L 3 ★**

AI3 voltage scaling parameter of 0%.

This parameter can be accessed if:

- **[PID Feedback] P, F** is set to **[AI3] R, 3**, and
- **[AI3 Type] R, 3 E** is not set to **[Voltage] I 0 U**.

Identical to **[AI1 min value] U, L 1** (see page 565).

**[AI3 max value] U, H 3 ★**

AI3 voltage scaling parameter of 100%.

This parameter can be accessed if:

- **[PID Feedback] P, F** is set to **[AI3] R, 3**, and
- **[AI3 Type] R, 3 E** is not set to **[Voltage] I 0 U**.

Identical to **[AI1 max value] U, H 1** (see page 566).

**[AI3 min. value] C, L 3 ★**

AI3 current scaling parameter of 0%.

This parameter can be accessed if:

- **[PID Feedback] P, F** is set to **[AI3] R, 3**, and
- **[AI3 Type] R, 3 E** is not set to **[Current] 0 R**.

Identical to **[AI1 min. value] C, L 1** (see page 566).

**[AI3 max. value] C r H 3 ★**

AI3 current scaling parameter of 100%.

This parameter can be accessed if:

- **[PID Feedback] P , F** is set to **[AI3] R , 3**, and
- **[AI3 Type] R , 3 E** is not set to **[Current] 0 R**.

Identical to **[AI1 max. value] C r H 1** (see page 566).

**[AI4 Type] R , 4 E ★**

Configuration of analog input AI4.

This parameter can be accessed if:

- VW3A3203 I/O extension module has been inserted, and
- **[PID Feedback] P , F** is set to **[AI4] R , 4**.

Setting	Code / Value	Description
<b>[Voltage]</b>	<b>1 0 u</b>	0-10 Vdc
<b>[Current]</b>	<b>0 R</b>	0-20 mA
<b>[Voltage +/-]</b>	<b>n 1 0 u</b>	-10/+10 Vdc <b>Factory setting</b>
<b>[PTC Management]</b>	<b>P E C</b>	1 to 6 PTC (in serial)
<b>[KTY]</b>	<b>K E Y</b>	1 KTY84
<b>[PT1000]</b>	<b>1 P E 3</b>	1 PT1000 connected with 2 wires
<b>[PT100]</b>	<b>1 P E 2</b>	1 PT100 connected with 2 wires
<b>[3 PT1000]</b>	<b>3 P E 3</b>	3 PT1000 connected with 2 wires
<b>[3 PT100]</b>	<b>3 P E 2</b>	3 PT100 connected with 2 wires
<b>[PT1000 in 3 wires]</b>	<b>1 P E 3 3</b>	1 PT1000 connected with 3 wires (AI4 & AI5 only)
<b>[PT100 in 3 wires]</b>	<b>1 P E 2 3</b>	1 PT100 connected with 3 wires (AI4 & AI5 only)
<b>[3 PT1000 in 3 wires]</b>	<b>3 P E 3 3</b>	3 PT1000 connected with 3 wires (AI4 & AI5 only)
<b>[3 PT100 in 3 wires]</b>	<b>3 P E 2 3</b>	3 PT100 connected with 3 wires (AI4 & AI5 only)

**[AI4 min value] u , L 4 ★**

AI4 voltage scaling parameter of 0%.

This parameter can be accessed if:

- **[PID Feedback] P , F** is set to **[AI4] R , 4**, and
- **[AI4 Type] R , 4 E** is not set to **[Voltage] 1 0 u**.

Identical to **[AI1 min value] u , L 1** (see page 565).

**[AI4 max value] u , H 4 ★**

AI4 voltage scaling parameter of 100%.

This parameter can be accessed if:

- **[PID Feedback] P , F** is set to **[AI4] R , 4**, and
- **[AI4 Type] R , 4 E** is not set to **[Voltage] 1 0 u**.

Identical to **[AI1 max value] u , H 1** (see page 566).

**[AI4 min. value] C r L 4 ★**

AI4 current scaling parameter of 0%.

This parameter can be accessed if:

- **[PID Feedback] P , F** is set to **[AI4] R , 4**, and
- **[AI4 Type] R , 4 E** is not set to **[Current] 0 R**.

Identical to **[AI1 min. value] C r L 1** (see page 566).



**[AI4 max. value] C r H 4 ★**

AI4 current scaling parameter of 100%.

This parameter can be accessed if:

- **[PID Feedback] P , F** is set to **[AI4] R , 4**, and
- **[AI4 Type] R , 4 E** is not set to **[Current] D R**.

Identical to **[AI1 max. value] C r H 1** (see page 566).

**[AI5 Type] R , 5 E ★**

Configuration of analog input AI5.

This parameter can be accessed if:

- VW3A3203 I/O extension module has been inserted, and
- **[PID Feedback] P , F** is set to **[AI5] R , 5**.

Identical to **[AI4 Type] R , 4 E**.

**[AI5 min value] u , L 5 ★**

AI5 voltage scaling parameter of 0%.

This parameter can be accessed if:

- **[PID Feedback] P , F** is set to **[AI5] R , 5**, and
- **[AI4 Type] R , 5 E** is not set to **[Voltage] I D u**.

Identical to **[AI1 min value] u , L 1** (see page 565).

**[AI5 max value] u , H 5 ★**

AI5 voltage scaling parameter of 100%.

This parameter can be accessed if:

- **[PID Feedback] P , F** is set to **[AI5] R , 5**, and
- **[AI4 Type] R , 5 E** is not set to **[Voltage] I D u**.

Identical to **[AI1 max value] u , H 1** (see page 566).

**[AI5 min. value] C r L 5 ★**

AI5 current scaling parameter of 0%.

This parameter can be accessed if:

- **[PID Feedback] P , F** is set to **[AI5] R , 5**, and
- **[AI5 Type] R , 5 E** is not set to **[Current] D R**.

Identical to **[AI1 min. value] C r L 1** (see page 566).

**[AI5 max. value] C r H 5 ★**

AI5 current scaling parameter of 100%.

This parameter can be accessed if:

- **[PID Feedback] P , F** is set to **[AI5] R , 5**, and
- **[AI5 Type] R , 5 E** is not set to **[Current] D R**.

Identical to **[AI1 max. value] C r H 1** (see page 566).

**[Min PID feedback] P , F 1 ★**

Minimum PID feedback.

This parameter can be accessed if **[PID Feedback] P , F** is not set to **[Not Configured] n o**.

Setting ( )	Description
0... <b>[Max PID feedback] P , F 2</b>	Setting range Factory setting: 100

**[Max PID feedback] P , F 2 ★**

Maximum PID feedback.

This parameter can be accessed if **[PID Feedback] P , F** is not set to **[Not Configured] n o .**

Setting ( )	Description
<b>[Min PID feedback] P , F 1...32,767</b>	Setting range <b>Factory setting:</b> 1,000

**[PID feedback] P F ★**

Value for PID feedback, display only.

This parameter can be accessed if **[PID Feedback] P , F** is not set to **[Not Configured] n o .**

Setting	Description
0...65,535	Setting range <b>Factory setting:</b> 0

**[Min Fbk Warning] P A L ★**

Minimum feedback level warning.

This parameter can be accessed if **[PID Feedback] P , F** is not set to **[Not Configured] n o .**

Setting ( )	Description
0...65,535	Setting range <b>Factory setting:</b> 100

**[Max Fbk Warning] P A H ★**

Maximum feedback level warning.

This parameter can be accessed if **[PID Feedback] P , F** is not set to **[Not Configured] n o .**

Setting ( )	Description
0...65,535	Setting range <b>Factory setting:</b> 1,000

## [Reference frequency] $r F$ - Menu

### Access

[Complete settings] → [Generic functions] → [PID controller] → [Reference frequency]

### About This Menu

**NOTE:** This function cannot be used with some other functions. Follow the instructions about the compatibility of functions.

### [Intern PID Ref] $P_{i1}$ ★

Internal PID reference.

This parameter can be accessed if [PID Feedback]  $P_{iF}$  is not set to [Not Configured]  $n o$ .

Setting	Code / Value	Description
[No]	$n o$	The PID controller reference is given by [Ref Freq 1 Config] $F_{r1}$ or [Ref.1B channel] $F_{r1b}$ with summing/subtraction/multiplication functions. Refer to the block diagram ( <a href="#">see page 305</a> ). <b>Factory setting</b>
[Yes]	$y e s$	The PID controller reference is internal via [Internal PID ref] $r P_{i1}$ .

### [Ref Freq 1 Config] $F_{r1}$ ★

Configuration reference frequency 1.

This parameter can be accessed if:

- [PID Feedback]  $P_{iF}$  is not set to [Not Configured]  $n o$ , and
- [Intern PID Ref]  $P_{i1}$  is set to [No]  $n o$ .

Setting	Code / Value	Description
[Not Configured]	$n o$	Not assigned
[AI1]	$A_{i1}$	Analog input AI1 <b>Factory Setting</b>
[AI2]...[AI3]	$A_{i2}...A_{i3}$	Analog input AI2...AI3
[AI4]...[AI5]	$A_{i4}...A_{i5}$	Analog input AI4...AI5 if VW3A3203 I/O extension module has been inserted
[Ref Frequency via DI]	$u P d t$	Up/Down function is assigned by DIx
[Ref. Freq-Modbus]	$m d b$	Reference frequency via Modbus
[Ref. Freq-CANopen]	$C A n$	Reference frequency via CANopen if a CANopen module has been inserted
[Ref. Freq-Com. Module]	$n e t$	Reference frequency via fieldbus module if a fieldbus module has been inserted
[Embedded Ethernet]	$E t H$	Embedded Ethernet
[PulseInput Assignment On DI5]...[PulseInput Assignment On DI6]	$P_{i5}...P_{i6}$	Digital input DI5...DI6 used as pulse input

### [Min PID reference] $P_{iP1}$ ★

Minimum PID reference.

This parameter can be accessed if [PID Feedback]  $P_{iF}$  is not set to [Not Configured]  $n o$ .

Setting ( )	Description
[Min PID feedback] $P_{iF1}$ ...[Max PID reference] $P_{iP2}$	Setting range <b>Factory setting:</b> 150

**[Max PID reference] P, P2 ★**

Maximum PID reference.

This parameter can be accessed if **[PID Feedback] P, F** is not set to **[Not Configured] no**.

Setting ( )	Description
<b>[Min PID reference] P, P1...[Max PID feedback] P, F2</b>	Setting range <b>Factory setting:</b> 900

**[Internal PID ref] r P, ★**

Internal PID reference.

This parameter can be accessed if:

- **[PID Feedback] P, F** is not set to **[Not Configured] no**, and
- **[Intern PID Ref] P, r** is set to **[Yes] YES**.

Setting ( )	Description
<b>[Min PID reference] P, P1...[Max PID reference] P, P2</b>	Setting range <b>Factory setting:</b> 150

**[Auto/Manual assign.] P A, ★**

Auto/Manual select input.

This parameter can be accessed if **[PID Feedback] P, F** is not set to **[Not Configured] no**.

Setting	Code / Value	Description
<b>[Not Assigned]</b>	no	Not assigned <b>Factory setting</b>
<b>[DI1]...[DI6]</b>	L, I...L, I6	Digital input DI1...DI6
<b>[DI11]...[DI16]</b>	L, I I I...L, I I6	Digital input DI11...DI16 if VW3A3203 I/O extension module has been inserted
<b>[CD00]...[CD10]</b>	C d 0 0...C d 1 0	Virtual digital input CMD.0...CMD.10 in <b>[I/O profile]</b> , no configuration
<b>[CD11]...[CD15]</b>	C d 1 1...C d 1 5	Virtual digital input CMD.11...CMD.15 regardless of configuration
<b>[C100]...[C110]</b>	C 1 0 0...C 1 1 0	Virtual digital input CMD1.0...CMD1.10 with integrated Modbus Serial in <b>[I/O profile]</b> , no configuration
<b>[C111]...[C115]</b>	C 1 1 1...C 1 1 5	Virtual digital input CMD1.11...CMD1.15 with integrated Modbus Serial regardless of configuration
<b>[C200]...[C210]</b>	C 2 0 0...C 2 1 0	Virtual digital input CMD2.0...CMD2.10 with CANopen® fieldbus module in <b>[I/O profile]</b> , no configuration
<b>[C211]...[C215]</b>	C 2 1 1...C 2 1 5	Virtual digital input CMD2.11...CMD2.15 with CANopen® fieldbus module regardless of configuration
<b>[C300]...[C310]</b>	C 3 0 0...C 3 1 0	Virtual digital input CMD3.0...CMD3.10 with a fieldbus module in <b>[I/O profile]</b> , no configuration
<b>[C311]...[C315]</b>	C 3 1 1...C 3 1 5	Virtual digital input CMD3.11...CMD3.15 with a fieldbus module regardless of configuration
<b>[C500]...[C510]</b>	C 5 0 0...C 5 1 0	Virtual digital input CMD5.0...CMD5.10 with integrated Ethernet Modbus TCP in <b>[I/O profile]</b> , no configuration
<b>[C511]...[C515]</b>	C 5 1 1...C 5 1 5	Virtual digital input CMD5.11...CMD5.15 with integrated Ethernet Modbus TCP regardless of configuration

**[Manual PID Reference] P , Π ★**

Manual PID reference.

Reference input in manual mode.

This parameter can be accessed if:

- **[PID Feedback] P , F** is not set to **[Not Configured] n o**, and
- **[Auto/Manual assign.] P R u** is not set to **[No] n o**.

The preset speeds are active on the manual reference if they have been configured.

Setting	Code / Value	Description
[No]	n o	Not assigned <b>Factory setting</b>
[AI1]...[AI3]	A , 1...A , 3	Analog input AI1...AI3
[AI4]...[AI5]	A , 4...A , 5	Analog input AI4...AI5 if VW3A3203 I/O extension module has been inserted
[Ref.Freq-Rmt.Term]	L C C	Display terminal source
[Ref. Freq-Modbus]	Π d b	Reference frequency via Modbus
[Ref. Freq- CANopen]	C A n	Reference frequency via CANopen
[Ref. Freq-Com. Module]	n E t	Reference frequency via Com Module
[Embedded Ethernet]	E t H	Embedded Ethernet source
[PulseInput Assignment On DI5]...[PulseInput Assignment On DI6]	P , 5...P , 6	Digital input DI5...DI6 used as pulse input

**[PID preset references] P r 1 - Menu****Access**

[Complete settings] → [Generic functions] → [PID controller] → [Reference frequency] → [PID preset references]

**About This Menu**

The function can be accessed if [PID feedback ass.] P r F is assigned.

**[2 PID Preset Assign] P r 2**

2 PID Preset assignment.

If the assigned input or bit is at 0, the function is inactive.

If the assigned input or bit is at 1, the function is active.

Setting	Code / Value	Description
[Not Assigned]	n o	Not assigned <b>Factory setting</b>
[DI1]...[DI6]	L 1 L ... L 6	Digital input DI1...DI6
[DI11]...[DI16]	L 11 L ... L 16	Digital input DI11...DI16 if VW3A3203 I/O extension module has been inserted
[CD00]...[CD10]	C d 0 0 ... C d 1 0	Virtual digital input CMD.0...CMD.10 in [I/O profile] configuration
[CD11]...[CD15]	C d 1 1 ... C d 1 5	Virtual digital input CMD.11...CMD.15 regardless of configuration
[C100]...[C110]	C 1 0 0 ... C 1 1 0	Virtual digital input CMD1.0...CMD1.10 with integrated Modbus Serial in [I/O profile] configuration
[C111]...[C115]	C 1 1 1 ... C 1 1 5	Virtual digital input CMD1.11...CMD1.15 with integrated Modbus Serial regardless of configuration
[C200]...[C210]	C 2 0 0 ... C 2 1 0	Virtual digital input CMD2.0...CMD2.10 with CANopen® fieldbus module in [I/O profile] configuration
[C211]...[C215]	C 2 1 1 ... C 2 1 5	Virtual digital input CMD2.11...CMD2.15 with CANopen® fieldbus module regardless of configuration
[C300]...[C310]	C 3 0 0 ... C 3 1 0	Virtual digital input CMD3.0...CMD3.10 with a fieldbus module in [I/O profile] configuration
[C311]...[C315]	C 3 1 1 ... C 3 1 5	Virtual digital input CMD3.11...CMD3.15 with a fieldbus module regardless of configuration
[C500]...[C510]	C 5 0 0 ... C 5 1 0	Virtual digital input CMD5.0...CMD5.10 with integrated Ethernet Modbus TCP in [I/O profile] configuration
[C511]...[C515]	C 5 1 1 ... C 5 1 5	Virtual digital input CMD5.11...CMD5.15 with integrated Ethernet Modbus TCP regardless of configuration
[DI1 (Low level)]...[DI6 (Low level)]	L 1 L ... L 6 L	Digital input DI1...DI6 used at low level
[DI11 (Low level)]...[DI16 (Low level)]	L 11 L ... L 16 L	Digital input DI11...DI16 used at low level if VW3A3203 I/O extension module has been inserted

**[4 PID Preset Assign] P r 4**

4 PID Preset assignment.

Identical to [2 PID Preset Assign] P r 2 (see page 574).

Verify that [2 PID Preset Assign] P r 2 has been assigned before assigning this function.

**[Ref PID Preset 2]  $r P 2$  ★**

Second PID preset reference.

This parameter can be accessed only if **[2 PID Preset Assign]  $P r 2$**  is assigned.

Setting ( )	Description
<b>[Min PID reference] <math>P , P 1</math>...[Max PID reference] <math>P , P 2</math></b>	Setting range <b>Factory setting:</b> 300

**[Ref PID Preset 3]  $r P 3$  ★**

Third PID preset reference.

This parameter can be accessed only if **[4 PID Preset Assign]  $P r 4$**  is assigned.

Setting ( )	Description
<b>[Min PID reference] <math>P , P 1</math>...[Max PID reference] <math>P , P 2</math></b>	Setting range <b>Factory setting:</b> 600

**[Ref PID Preset 4]  $r P 4$  ★**

Fourth PID preset reference.

This parameter can be accessed only if **[4 PID Preset Assign]  $P r 4$**  and **[2 PID Preset Assign]  $P r 2$**  are assigned.

Setting ( )	Description
<b>[Min PID reference] <math>P , P 1</math>...[Max PID reference] <math>P , P 2</math></b>	Setting range <b>Factory setting:</b> 900

**[Reference frequency]  $r F$  - Menu****Access**

[Complete settings] → [Generic functions] → [PID controller] → [Reference frequency]

**[Predictive Speed Ref]  $F P$  , ★**

Predictive speed reference.

This parameter can be accessed if [Access Level]  $L R C$  is set to [Expert]  $E P r$ .

Setting	Code / Value	Description
[No]	$n a$	Not assigned <b>Factory setting</b>
[AI1]...[AI3]	$A 1, 1 \dots A 1, 3$	Analog input AI1...AI3
[AI4]...[AI5]	$A 1, 4 \dots A 1, 5$	Analog input AI4...AI5 if VW3A3203 I/O extension module has been inserted
[Ref.Freq-Rmt.Term]	$L C C$	Reference frequency via remote terminal
[Ref. Freq-Modbus]	$M d b$	Reference frequency via Modbus
[Ref. Freq- CANopen]	$C A n$	Reference frequency via CANopen
[Ref. Freq-Com. Module]	$n E t$	Reference frequency via communication module
[Embedded Ethernet]	$E t H$	Embedded Ethernet
[PulseInput Assignment On DI5]...[PulseInput Assignment On DI6]	$P 1, 5 \dots P 1, 6$	Digital input DI5...DI6 used as pulse input

**[Speed Input %]  $P S r$  ★**

PID speed input % reference.

This parameter can be accessed if [Access Level]  $L R C$  is set to [Expert]  $E P r$ .

Setting ( )	Description
1...100%	Setting range <b>Factory setting:</b> 100%



## [Settings] 5 L - Menu

### Access

[Complete settings] → [Generic functions] → [PID controller] → [Settings]

### About This Menu

Following parameters can be accessed if [PID Feedback]  $P, F$  is not set to [Not Configured]  $n \emptyset$ .

**NOTE:** This function cannot be used with some other functions. Follow the instructions about the compatibility of functions.

### [PID Prop.Gain] $r P G$ ★

PID proportional gain.

Setting ( )	Description
0.01...100.00	Setting range <b>Factory setting:</b> 1.00

### [PI Intgl.Gain] $r I G$ ★

Integral gain.

Setting ( )	Description
0.01...100.00	Setting range <b>Factory setting:</b> 1.00

### [PID derivative gain] $r d G$ ★

Derivative gain.

Setting ( )	Description
0.00...100.00	Setting range <b>Factory setting:</b> 0.00

### [PID ramp] $P r P$ ★

PID acceleration/deceleration ramp, defined to go from [Min PID reference]  $P, P 1$  to [Max PID reference]  $P, P 2$  and conversely.

Setting ( )	Description
0.0...99.9 s	Setting range <b>Factory setting:</b> 0.0 s

### [PID Inversion] $P, I$ ★

PID inversion.

Setting	Code / Value	Description
[No]	$n \emptyset$	No <b>Factory setting</b>
[YES]	$Y E S$	Yes

**[PID Min Output] P o L ★**

PID controller minimum output in Hz.

Setting ( )	Description
0.0...500.0 Hz	Setting range <b>Factory setting:</b> 0.0 Hz

**[PID Max Output] P o H ★**

PID controller maximum output in Hz.

Setting ( )	Description
0.0...500.0 Hz	Setting range <b>Factory setting:</b> 60.0 Hz

**[PID Error Warning] P E r ★**

PID error warning.

Setting ( )	Description
0...65,535	Setting range <b>Factory setting:</b> 100

**[PID Integral OFF] P , 5 ★**

Integral shunt.

If the assigned input or bit is at 0, the function is inactive (the PID integral is enabled).

If the assigned input or bit is at 1, the function is active (the PID integral is disabled).

Setting	Code / Value	Description
[Not Assigned]	n o	Not assigned <b>Factory setting</b>
[DI1]...[DI6]	L , 1...L , 6	Digital input DI1...DI6
[DI11]...[DI16]	L , 11...L , 16	Digital input DI11...DI16 if VW3A3203 I/O extension module has been inserted
[CD00]...[CD10]	C d 0 0...C d 1 0	Virtual digital input CMD.0...CMD.10 in <b>[I/O profile]</b> , o configuration
[CD11]...[CD15]	C d 1 1...C d 1 5	Virtual digital input CMD.11...CMD.15 regardless of configuration
[C100]...[C110]	C 1 0 0...C 1 1 0	Virtual digital input CMD1.0...CMD1.10 with integrated Modbus Serial in <b>[I/O profile]</b> , o configuration
[C111]...[C115]	C 1 1 1...C 1 1 5	Virtual digital input CMD1.11...CMD1.15 with integrated Modbus Serial regardless of configuration
[C200]...[C210]	C 2 0 0...C 2 1 0	Virtual digital input CMD2.0...CMD2.10 with CANopen® fieldbus module in <b>[I/O profile]</b> , o configuration
[C211]...[C215]	C 2 1 1...C 2 1 5	Virtual digital input CMD2.11...CMD2.15 with CANopen® fieldbus module regardless of configuration
[C300]...[C310]	C 3 0 0...C 3 1 0	Virtual digital input CMD3.0...CMD3.10 with a fieldbus module in <b>[I/O profile]</b> , o configuration
[C311]...[C315]	C 3 1 1...C 3 1 5	Virtual digital input CMD3.11...CMD3.15 with a fieldbus module regardless of configuration
[C500]...[C510]	C 5 0 0...C 5 1 0	Virtual digital input CMD5.0...CMD5.10 with integrated Ethernet Modbus TCP in <b>[I/O profile]</b> , o configuration
[C511]...[C515]	C 5 1 1...C 5 1 5	Virtual digital input CMD5.11...CMD5.15 with integrated Ethernet Modbus TCP regardless of configuration

**[PID acceleration time] ACCP** ★

PID: acceleration during start-up.

PID start ramp can be applied before starting the PID controller to allow reaching quickly the PID reference without increasing PID gains. If configured, the **[Start Accel Ramp] ACCS** is applied up to **[Low Speed] LSP** instead of **[PID acceleration time] ACCP**.

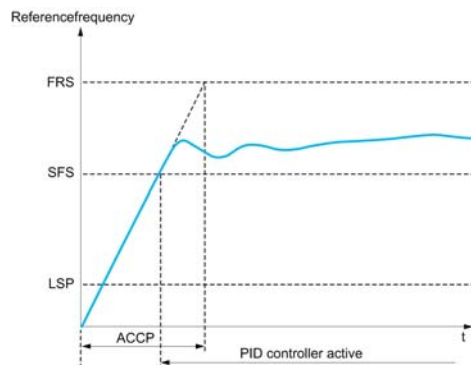

Setting ( )	Description
0.01...99,99 s	Setting range <b>Factory setting:</b> 0.50 s
(1) Range 0.01 to 99.99 s or 0.1 to 999.9 s or 1 to 6,000 according to <b>[Ramp increment] IIR</b>	

**[PID Start Ref Freq] SFS** ★

PID start reference frequency.

Setting ( )	Description
0.0...500.0 Hz	Setting range If <b>[PID Start Ref Freq] SFS</b> is lower than <b>[Low speed] LSP</b> , this function has no effect. <b>Factory setting:</b> 0.0 Hz

## Section 7.42

### [Generic functions] - [Feedback mon.]

---

#### [Feedback monitoring] F K Π - Menu

##### Access

[Complete settings] → [Generic functions] → [Feedback monitoring]

##### About This Menu

Identical to [Feedback monitoring] F K Π - Menu (*see page 365*).

## Section 7.43

### [Generic functions] - [Threshold reached]

#### [Threshold reached] *E H r E* - Menu

##### Access

[Complete settings] → [Generic functions] → [Threshold reached]

##### [Low I Threshold] *C E d L*

Current low threshold value.

Setting ( )	Description
0...65,535 A	Setting range <b>Factory setting:</b> 0 A

##### [High Current Thd] *C E d*

Current high threshold value.

Setting ( )	Description
0...65,535 A	Setting range <b>Factory setting:</b> Drive nominal current

##### [Low Freq. Threshold] *F E d L*

Motor low frequency threshold.

Setting ( )	Description
0.0...500.0 Hz	Setting range <b>Factory setting:</b> 0.0 Hz

##### [Motor Freq Thd] *F E d*

Motor frequency threshold.

Setting ( )	Description
0.0...500.0 Hz	Setting range <b>Factory setting:</b> 50.0 Hz

##### [2 Freq. Threshold] *F 2 d L*

Motor low frequency second threshold.

Setting ( )	Description
0.0...500.0 Hz	Setting range <b>Factory setting:</b> 0.0 Hz

##### [Freq. threshold 2] *F 2 d*

Motor frequency threshold 2.

Setting ( )	Description
0.0...500.0 Hz	Setting range <b>Factory setting:</b> 50.0 Hz

**[Motor Thermal Thd]** *ℓ ℓ d*

Motor thermal state threshold.

Setting 	Description
0...118%	Setting range <b>Factory setting:</b> 100%

**[Reference high Thd]** *r ℓ d*

Reference frequency high threshold.

Setting 	Description
0.0...500.0 Hz	Setting range <b>Factory setting:</b> 0.0 Hz

**[Reference low Thd]** *r ℓ d L*

Reference low threshold.

Setting 	Description
0.0...500.0 Hz	Setting range <b>Factory setting:</b> 0.0 Hz

## Section 7.44

### [Generic functions] - [Mains contactor command]

#### [Mains contactor command] L L C - Menu

##### Access

[Complete settings] → [Generic functions] → [Mains contactor command]

##### About This Menu

The line contactor closes every time a run command (forward or reverse) is sent and opens after every stop, as soon as the drive is locked. For example, if the stop mode is stop on ramp, the contactor opens when the motor reaches zero speed.

**NOTE:** The drive control power supply must be provided via an external 24 Vdc source.

### NOTICE

#### DAMAGE TO THE DRIVE

This function must not be activated with a cycle shorter than 60 s.

**Failure to follow these instructions can result in equipment damage.**

Example circuit (24 Vdc power supply):

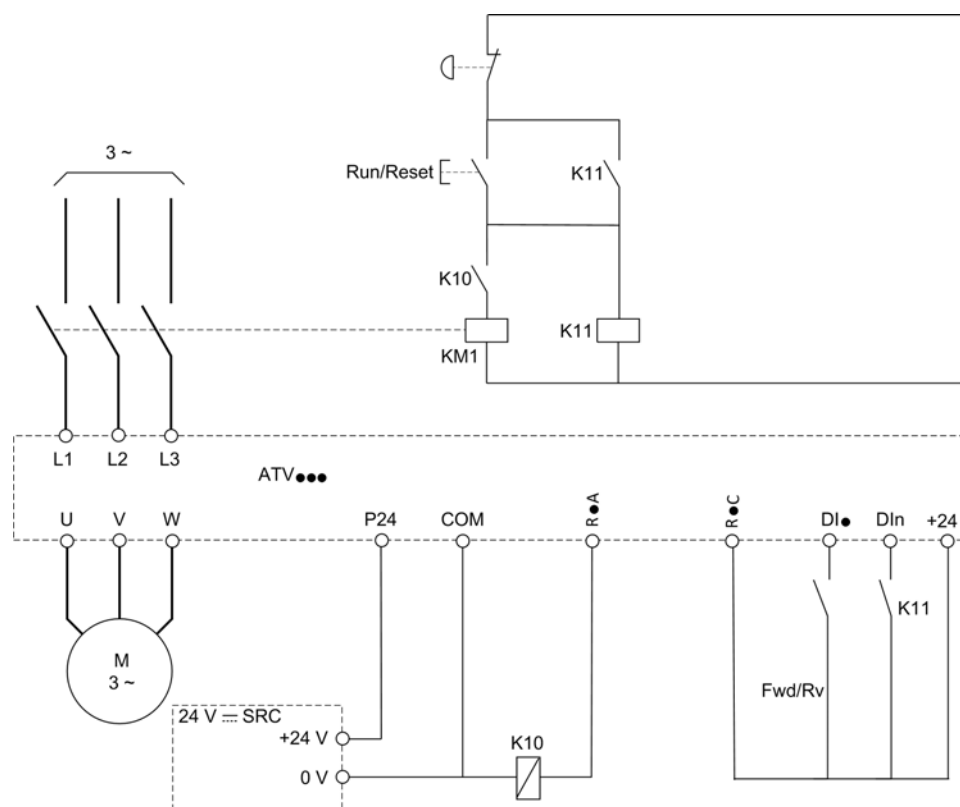

Dli = Run command [Forward] F r d or [Reverse] r r 5

RiA/RiC = [Mains Contactor] L L C

DIn = [Drive Lock] L E 5

**NOTE:** The Run/Reset key must be pressed once the emergency stop key has been released.

**[Mains Contactor] L L C**

Mains contactor control.

Setting	Code / Value	Description
[No]	<i>n o</i>	Not assigned <b>Factory setting</b>
[R2]...[R3]	<i>r 2...r 3</i>	Relay output R2...R3
[R4]...[R6]	<i>r 4...r 6</i>	Relay output R4...R6 if VW3A3204 relay output option module has been inserted
[Analog output DQ11]...[Analog output DQ12]	<i>d o 1 1...d o 1 2</i>	Analog / digital output DO11...DO12 if VW3A3203 I/O extension module has been inserted

**[Drive Lock] L E 5 ★**

Drive lock assignment.

This parameter can be accessed if **[Mains Contactor] L L C** is not set to **[No] n o**.

Setting	Code / Value	Description
[Not Assigned]	<i>n o</i>	Not assigned <b>Factory setting</b>
[DI1]...[DI6]	<i>L , 1...L , 6</i>	Digital input DI1...DI6
[DI11]...[DI16]	<i>L , 1 1...L , 1 6</i>	Digital input DI11...DI16 if VW3A3203 I/O extension module has been inserted
[CD00]...[CD10]	<i>C d 0 0...C d 1 0</i>	Virtual digital input CMD.0...CMD.10 in <b>[I/O profile] , o</b> configuration
[CD11]...[CD15]	<i>C d 1 1...C d 1 5</i>	Virtual digital input CMD.11...CMD.15 regardless of configuration
[C100]...[C110]	<i>C 1 0 0...C 1 1 0</i>	Virtual digital input CMD1.0...CMD1.10 with integrated Modbus Serial in <b>[I/O profile] , o</b> configuration
[C111]...[C115]	<i>C 1 1 1...C 1 1 5</i>	Virtual digital input CMD1.11...CMD1.15 with integrated Modbus Serial regardless of configuration
[C200]...[C210]	<i>C 2 0 0...C 2 1 0</i>	Virtual digital input CMD2.0...CMD2.10 with CANopen® fieldbus module in <b>[I/O profile] , o</b> configuration
[C211]...[C215]	<i>C 2 1 1...C 2 1 5</i>	Virtual digital input CMD2.11...CMD2.15 with CANopen® fieldbus module regardless of configuration
[C300]...[C310]	<i>C 3 0 0...C 3 1 0</i>	Virtual digital input CMD3.0...CMD3.10 with a fieldbus module in <b>[I/O profile] , o</b> configuration
[C311]...[C315]	<i>C 3 1 1...C 3 1 5</i>	Virtual digital input CMD3.11...CMD3.15 with a fieldbus module regardless of configuration
[C500]...[C510]	<i>C 5 0 0...C 5 1 0</i>	Virtual digital input CMD5.0...CMD5.10 with integrated Ethernet Modbus TCP in <b>[I/O profile] , o</b> configuration
[C511]...[C515]	<i>C 5 1 1...C 5 1 5</i>	Virtual digital input CMD5.11...CMD5.15 with integrated Ethernet Modbus TCP regardless of configuration

**[Mains V. time out] L C E ★**

Monitoring time for closing of line contactor.

This parameter can be accessed if **[Mains Contactor] L L C** is not set to **[No] n o**.

Setting	Description
5...999 s	Setting range <b>Factory setting:</b> 5 s



## Section 7.45

### [Generic functions] - [Reverse disable]

#### [Reverse disable] r E 1 n - Menu

##### Access

[Complete settings] → [Generic functions] → [Reverse disable]

##### [Reverse Disable] r 1 n

Reverse direction disable.

**NOTE:** Anti-Jam function takes priority over **[Reverse Disable] r 1 n** function. If an Anti-Jam function is used, reverse direction is applied despite of the **[Reverse disable] r 1 n** configuration.

Reverse direction requests sent by digital inputs are taken into account.

Reverse direction requests sent by the Graphic Display Terminal or sent by the line are not taken into account.

Any reverse speed reference originating from the PID, summing input, and so on, is interpreted as a zero reference (0 Hz).

Setting	Code / Value	Description
[No]	n 0	No
[Yes]	4 E 5	Yes Factory setting

## Section 7.46

### [Generic functions] - [Torque limitation]

#### [Torque limitation] $EOL$ - Menu

##### Access

[Complete settings] → [Generic functions] → [Torque limitation]

##### About This Menu

There are 2 types of torque limitation:

- With a value that is fixed by a parameter
- With a value that is set by an analog input (AI or pulse)

If both types are enabled, the lowest value is taken into account.

The 2 types of limitation can be configured or switched remotely using a digital input or via the communication bus.

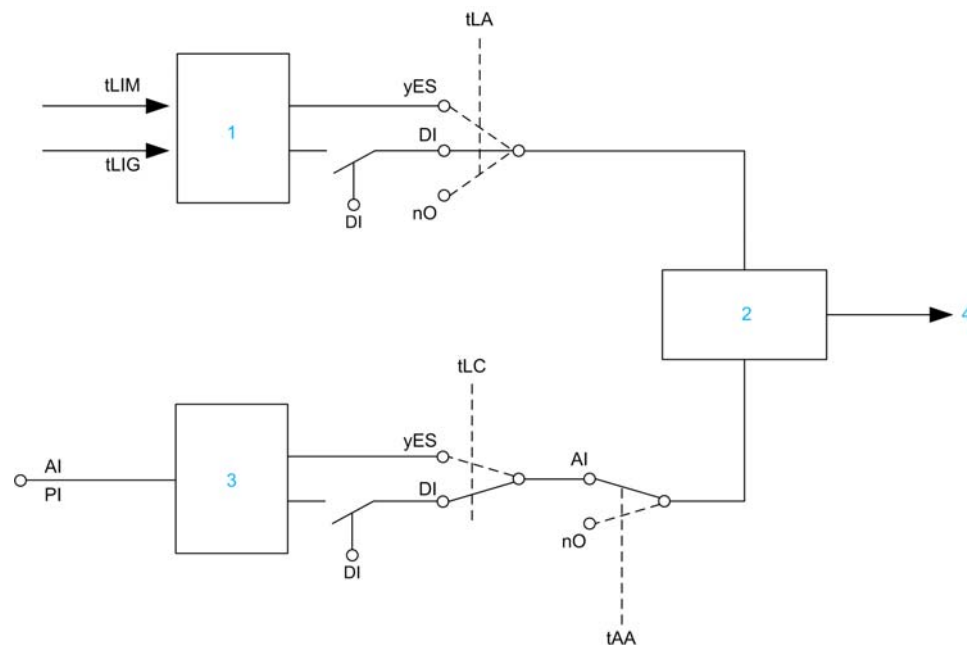

- 1 Torque limitation via parameter.
- 2 Lowest value taken into account.
- 3 Torque limitation via analog input, RP.
- 4 Limitation value.

**[Torque limit activ.]**  $\text{L L A}$ 

If the assigned input or bit is at 0, the function is inactive.

If the assigned input or bit is at 1, the function is active.

Setting	Code / Value	Description
[Not Assigned]	$n a$	Not assigned <b>Factory setting</b>
[Yes]	$y e s$	Yes
[DI1]...[DI6]	$L , I \dots L , 6$	Digital input DI1...DI6
[DI11]...[DI16]	$L , I I \dots L , 16$	Digital input DI11...DI16, if VW3A3203 I/O extension module has been inserted
[CD00]...[CD10]	$C d 0 0 \dots C d 1 0$	Virtual digital input CMD.0...CMD.10 in <b>[I/O profile]</b> , $a$ configuration
[CD11]...[CD15]	$C d 1 1 \dots C d 1 5$	Virtual digital input CMD.11...CMD.15 regardless of configuration
[C100]...[C110]	$C 1 0 0 \dots C 1 1 0$	Virtual digital input CMD1.0...CMD1.10 with integrated Modbus serial in <b>[I/O profile]</b> , $a$ configuration
[C111]...[C115]	$C 1 1 1 \dots C 1 1 5$	Virtual digital input CMD1.11...CMD1.15 with integrated Modbus serial regardless of configuration
[C200]...[C210]	$C 2 0 0 \dots C 2 1 0$	Virtual digital input CMD2.0...CMD2.10 with CANopen® fieldbus module in <b>[I/O profile]</b> , $a$ configuration
[C211]...[C215]	$C 2 1 1 \dots C 2 1 5$	Virtual digital input CMD2.11...CMD2.15 with CANopen® fieldbus module regardless of configuration
[C300]...[C310]	$C 3 0 0 \dots C 3 1 0$	Virtual digital input CMD3.0...CMD3.10 with a fieldbus module in <b>[I/O profile]</b> , $a$ configuration
[C311]...[C315]	$C 3 1 1 \dots C 3 1 5$	Virtual digital input CMD3.11...CMD3.15 with a fieldbus module regardless of configuration
[C500]...[C510]	$C 5 0 0 \dots C 5 1 0$	Virtual digital input CMD5.0...CMD5.10 with integrated Ethernet ModbusTCP in <b>[I/O profile]</b> , $a$ configuration
[C511]...[C515]	$C 5 1 1 \dots C 5 1 5$	Virtual digital input CMD5.11...CMD5.15 with integrated Ethernet ModbusTCP regardless of configuration

**[Pmax Motor]**  $\text{L P M A}$  ★

Maximum acceptable power in motor mode.

This parameter can be accessed if **[Torque limit activ.]**  $\text{L L A}$  is not set to **[Not Assigned]**  $n a$ .

Setting ( )	Description
10...300%	Setting range <b>Factory setting:</b> 300%

**[Pmax Generator]**  $\text{L P G A}$  ★

Maximum acceptable power in generator mode.

This parameter can be accessed if **[Torque limit activ.]**  $\text{L L A}$  is not set to **[Not Assigned]**  $n a$ .

Setting ( )	Description
10...300%	Setting range <b>Factory setting:</b> 300%

---

## Section 7.47

### [Generic functions] - [Parameters switching]

---

#### What Is in This Section?

This section contains the following topics:

Topic	Page
[Parameters switching] <i>PLP</i> - Menu	589
[Set 1] <i>P51</i> - Menu	594
[Set 2] <i>P52</i> - Menu	595
[Set 3] <i>P53</i> - Menu	596

## [Parameters switching] *PLP* - Menu

### Access

[Complete settings] → [Generic functions] → [Parameters switching]

### About This Menu

A set of 1 to 15 parameters from the [Parameter Selection] *SP5* list (see page 590) can be selected and 2 or 3 different values assigned. These 2 or 3 sets of values can then be switched using 1 or 2 digital inputs or control word bits. This switching can be performed during operation (motor running). It can also be controlled based on 1 or 2 frequency thresholds, whereby each threshold acts as a digital input (0 = threshold not reached, 1 = threshold reached).

	Values 1	Values 2	Values 3
Parameter 1 ... Parameter 15	Parameter 1 ... Parameter 15	Parameter 1 ... Parameter 15	Parameter 1 ... Parameter 15
Input DI or bit or frequency threshold 2 values	0	1	0 or 1
Input DI or bit or frequency threshold 3 values	0	0	1

**NOTE:** Do not modify the parameters in [Parameter Selection] *SP5* (see page 590), because any modifications made in this menu will be lost on the next power-up. The parameters can be adjusted during operation in the [Parameters switching] *PLP* - menu, on the active configuration.

### [2 Parameter sets] *CHRI*

Parameter switching assignment 1.

Setting	Code / Value	Description
[Not assigned]	<i>no</i>	Not assigned <b>Factory setting</b>
[Motor Freq High Thd]	<i>FtR</i>	Motor frequency high threshold reached
[2nd Freq Thd Reached]	<i>F2R</i>	2nd frequency threshold reached
[DI1]...[DI6]	<i>L 1 I...L 6</i>	Digital input DI1...DI6
[DI11]...[DI16]	<i>L 11 I...L 16</i>	Digital input DI11...DI16 if VW3A3203 I/O extension module has been inserted
[CD00]...[CD10]	<i>C d 0 0...C d 1 0</i>	Virtual digital input CMD.0...CMD.10 in [I/O profile] <i>io</i> configuration
[CD11]...[CD15]	<i>C d 1 1...C d 1 5</i>	Virtual digital input CMD.11...CMD.15 regardless of configuration
[C100]...[C110]	<i>C 1 0 0...C 1 1 0</i>	Virtual digital input CMD1.0...CMD1.10 with integrated Modbus Serial in [I/O profile] <i>io</i> configuration
[C111]...[C115]	<i>C 1 1 1...C 1 1 5</i>	Virtual digital input CMD1.11...CMD1.15 with integrated Modbus Serial regardless of configuration
[C200]...[C210]	<i>C 2 0 0...C 2 1 0</i>	Virtual digital input CMD2.0...CMD2.10 with CANopen® fieldbus module in [I/O profile] <i>io</i> configuration
[C211]...[C215]	<i>C 2 1 1...C 2 1 5</i>	Virtual digital input CMD2.11...CMD2.15 with CANopen® fieldbus module regardless of configuration
[C300]...[C310]	<i>C 3 0 0...C 3 1 0</i>	Virtual digital input CMD3.0...CMD3.10 with a fieldbus module in [I/O profile] <i>io</i> configuration
[C311]...[C315]	<i>C 3 1 1...C 3 1 5</i>	Virtual digital input CMD3.11...CMD3.15 with a fieldbus module regardless of configuration
[C500]...[C510]	<i>C 5 0 0...C 5 1 0</i>	Virtual digital input CMD5.0...CMD5.10 with integrated Ethernet ModbusTCP in [I/O profile] <i>io</i> configuration
[C511]...[C515]	<i>C 5 1 1...C 5 1 5</i>	Virtual digital input CMD5.11...CMD5.15 with integrated Ethernet ModbusTCP regardless of configuration

**[3 Parameter sets] C H R 2**

Parameter switching assignment 2.

Identical to **[2 Parameter sets] C H R 1**.

Switching 3 parameter sets.

**NOTE:** In order to obtain 3 parameter sets, it is necessary to configure first **[2 Parameter sets] C H R 1**.

**[Parameter Selection] 5 P 5**

This parameter can be accessed if **[2 Parameter sets] C H R 1** is not set to **[No] n o**.

Making an entry in this parameter opens a window containing all the adjustment parameters that can be accessed. Select 1 to 15 parameters using **OK** key. Parameter(s) can also be deselected using **OK** key.

Available parameters for parameters switching function are:

Parameter	Code
[Ramp increment]	<i>i n r</i>
[Acceleration]	<i>A C C</i>
[Deceleration]	<i>d E C</i>
[Acceleration 2]	<i>A C 2</i>
[Deceleration 2]	<i>d E 2</i>
[Begin Acc round]	<i>t A 1</i>
[End Acc round]	<i>t A 2</i>
[Begin Dec round]	<i>t A 3</i>
[End Dec round]	<i>t A 4</i>
[Low Speed]	<i>L S P</i>
[High Speed]	<i>H S P</i>
[Motor Th Current]	<i>i t H</i>
[IR compensation]	<i>u F r</i>
[Slip compensation]	<i>S L P</i>
[K speed loop filter]	<i>S F C</i>
[Speed time integral]	<i>S i t</i>
[Speed prop. gain]	<i>S P G</i>
[Inertia Factor]	<i>S P G u</i>
[Ramp Divider]	<i>d C F</i>
[DC Inj Level 1]	<i>i d C</i>
[DC Inj Time 1]	<i>t d i</i>
[DC Inj Level 2]	<i>i d C 2</i>
[DC Inj Time 2]	<i>t d C</i>
[Auto DC inj Level 1]	<i>S d C 1</i>
[Auto DC Inj Time 1]	<i>t d C 1</i>
[Auto DC inj Level 2]	<i>S d C 2</i>
[Auto DC Inj Time 2]	<i>t d C 2</i>
[Switching frequency]	<i>S F r</i>
[Current Limitation]	<i>C L i</i>
[Low Speed Timeout]	<i>t L S</i>
[Sleep Offset Thres.]	<i>S L E</i>
[Preset speed 2]...[Preset speed 16]	<i>S P 2... S P 1 6</i>
[Multiplying coeff.]	<i>Π F r</i>
[PID Prop.Gain]	<i>r P G</i>
[PID Intgl.Gain]	<i>r i G</i>
[PID derivative gain]	<i>r d G</i>
[PID ramp]	<i>P r P</i>
[PID Min Output]	<i>P o L</i>
[PID Max Output]	<i>P o H</i>

Parameter	Code
[PID Start Ref Freq]	<i>S F 5</i>
[PID acceleration time]	<i>A C C P</i>
[Min fbk Warning]	<i>P R L</i>
[Max fbk Warning]	<i>P R H</i>
[PID error Warning]	<i>P E r</i>
[Speed input %]	<i>P S r</i>
[Ref PID Preset 2]	<i>r P 2</i>
[Ref PID Preset 3]	<i>r P 3</i>
[Ref PID Preset 4]	<i>r P 4</i>
[PID Fdbk Range]	<i>P F Π r</i>
[PID Fdbk Error Delay]	<i>P F Π d</i>
[High Current Thd]	<i>C t d</i>
[Low I Threshold]	<i>C t d L</i>
[Motor Freq Thd]	<i>F t d</i>
[Low Freq.Threshold]	<i>F t d L</i>
[Freq. threshold 2]	<i>F 2 d</i>
[2 Freq. Threshold]	<i>F 2 d L</i>
[Freewheel stop Thd]	<i>F F t</i>
[Motor Therm Thd]	<i>t t d</i>
[Reference high Thd]	<i>r t d</i>
[Reference low Thd]	<i>r t d L</i>
[Skip Frequency]	<i>J P F</i>
[Skip Frequency 2]	<i>J F 2</i>
[3rd Skip Frequency]	<i>J F 3</i>
[Skip Freq.Hysteresis]	<i>J F H</i>
[Unld.Thr.Nom.Speed]	<i>L u n</i>
[Unld.Thr.0.Speed]	<i>L u L</i>
[Unld. FreqThr. Det.]	<i>r Π u d</i>
[Hysteresis Freq]	<i>S r b</i>
[Underload T.B.Rest.]	<i>F t u</i>
[Ovld Detection Thr.]	<i>L o C</i>
[Overload T.B.Rest.]	<i>F t o</i>
[Fan mode]	<i>F F Π</i>
[Pmax Motor]	<i>t P Π Π</i>
[Pmax Generator]	<i>t P Π G</i>
[Stall Max Time]	<i>S t P 1</i>
[Stall Current]	<i>S t P 2</i>
[Stall Frequency]	<i>S t P 3</i>
[AI2 Th Warn Level]	<i>t H 2 R</i>
[AI5 Th Warn Level]	<i>t H 5 R</i>
[AI2 Th Error Level]	<i>t H 2 F</i>
[AI5 Th Error Level]	<i>t H 5 F</i>
[Start Accel Ramp]	<i>A C C S</i>
[Dec. Check Valve]	<i>d E C u</i>
[Check Valve Speed 2]	<i>C u H S</i>
[Check Valve Speed 1]	<i>C u L S</i>
[Final Dec. Ramp]	<i>d E C S</i>
[Sleep Flow Level]	<i>S L n L</i>
[Sleep Min Speed]	<i>S L S L</i>
[Sleep Power Level]	<i>S L P r</i>

Parameter	Code
[Sleep Pressure Level]	<i>S L P L</i>
[Sleep Delay]	<i>S L P d</i>
[Sleep Boost Speed]	<i>S L b S</i>
[Sleep Boost Time]	<i>S L b t</i>
[Wake Up Process level]	<i>W u P F</i>
[Wake Up Process Error]	<i>W u P E</i>
[Wake Up Press level]	<i>W u P L</i>
[Sleep Condition]	<i>R S L C</i>
[Sleep Check Delay]	<i>R S L d</i>
[Check Sleep Ref spd]	<i>R S L r</i>
[Flow Lim Thd Active]	<i>C H t</i>
[FlowLim Thd Disable]	<i>r C H t</i>
[Flow. Limit Dec.]	<i>d F L</i>
[Pipe Fill TiMe]	<i>P F H t</i>
[Pipe Fill SPeed]	<i>P F H S</i>
[Pipe Fill Pressure]	<i>P F H P</i>
[Priming Time]	<i>P P S d</i>
[Primed Inlet Level]	<i>P P i L</i>
[Primed Condition Delay]	<i>P P F d</i>
[Minimum Pressure]	<i>J P r P</i>
[Delay to start]	<i>J P r d</i>
[Maximum Pressure]	<i>J P S P</i>
[Reference Speed]	<i>J P r S</i>
[Wake up Delay]	<i>J P W d</i>
[Alpha]	<i>F L d R</i>
[Comp. at Point 1]	<i>F L H I</i>
[Flow at Point 1]	<i>F L 9 I</i>
[Static Compensation]	<i>F L H 0</i>
[OutPres Min Level]	<i>o P P L</i>
[OutPres Max Level]	<i>o P P H</i>
[OutPresError Delay]	<i>o P P d</i>
[HighFlow MaxLevel]	<i>H F P L</i>
[HighFlowError Delay]	<i>H F P d</i>
[PumpCycle MaxStarts]	<i>P C P n</i>
[PumpCycle Timeframe]	<i>P C P t</i>
[InletPres High Thd]	<i>i P P H</i>
[InletPres Low Thd]	<i>i P P L</i>
[InletPres Max Comp]	<i>i P P C</i>
[Anti-Jam Trigger Time]	<i>J t C t</i>
[Anti-Jam Torque]	<i>J t C L</i>
[Anti-Jam Start Delay]	<i>J t C d</i>
[Anti-Jam Fwd Dec]	<i>J d E C</i>
[Anti-Jam Rv Dec]	<i>J d E r</i>
[Anti-Jam Fwd Acc]	<i>J R C C</i>
[Anti-Jam Rv Acc]	<i>J R C r</i>
[Anti-Jam Fwd Time]	<i>J F d t</i>
[Anti-Jam Rv Time]	<i>J r u t</i>
[Anti-Jam Fwd Speed]	<i>J F d S</i>
[Anti-Jam Rv Speed]	<i>J r u S</i>
[Anti-Jam Stop Time]	<i>J Z S t</i>



Parameter	Code
[Anti-Jam Cycle Nb]	<i>J n b C</i>
[Anti-Jam Max Seq]	<i>J R n n</i>
[Anti-Jam Interval]	<i>J R n t</i>
[DryRun Error Delay]	<i>d r Y d</i>
[DryRun Restart Delay]	<i>d r Y r</i>
[Dry Run Factor]	<i>d r Y X</i>
[PumpLF Min Level]	<i>P L F L</i>
[PumpLF Power Factor]	<i>P L F X</i>
[PumpLF ActivDelay]	<i>P L F A</i>
[PumpLF Error Delay]	<i>P L F d</i>
[PumpLF Restart Delay]	<i>P L F r</i>
[LevelCtrl Random Factor]	<i>L C r X</i>
[Level 1st Pump Start]	<i>L r L 1</i>
[Level 2nd Pump Start]	<i>L r L 2</i>
[Level 3rd Pump Start]	<i>L r L 3</i>
[Level 4th Pump Start]	<i>L r L 4</i>
[Level 5th Pump Start]	<i>L r L 5</i>
[Level 6th Pump Start]	<i>L r L 6</i>
[Level 1st Pump Stop]	<i>L P L 1</i>
[Level 2nd Pump Stop]	<i>L P L 2</i>
[Level 3rd Pump Stop]	<i>L P L 3</i>
[Level 4th Pump Stop]	<i>L P L 4</i>
[Level 5th Pump Stop]	<i>L P L 5</i>
[Level 6th Pump Stop]	<i>L P L 6</i>
[Level 1st Pump at HSP]	<i>L H L 1</i>
[Level 2nd Pump at HSP]	<i>L H L 2</i>
[Level 3rd Pump at HSP]	<i>L H L 3</i>
[Level 4th Pump at HSP]	<i>L H L 4</i>
[Level 5th Pump at HSP]	<i>L H L 5</i>
[Level 6th Pump at HSP]	<i>L H L 6</i>
[LevelCtrl Low Speed]	<i>L C L S</i>
[Min Delivery Height]	<i>L C d H</i>
[Booster Stg Speed]	<i>b S S</i>
[Booster Dstg Speed]	<i>b d S</i>
[Booster Stg Delay]	<i>b S d</i>
[Booster Stg Bypass Speed]	<i>b S b S</i>
[Booster Stg Ramp Delay]	<i>b S r d</i>
[Booster Stg Bypass Time]	<i>b S b t</i>
[Booster Dstg Delay]	<i>b d d</i>
[Booster Dstg Bypass Spd]	<i>b d b S</i>
[Booster Dstg Ramp Delay]	<i>b d r d</i>
[Booster Dstg Bypass Time]	<i>b d b t</i>
[Booster S/D Interval]	<i>b S d t</i>
[Booster Working Range]	<i>b C W R</i>
[Booster Override Range]	<i>b C o R</i>
[FeedFwd Stage Delay]	<i>F F S d</i>
[FeedFwd Destage Delay]	<i>F F d d</i>
[FeedFwd Disturb Gain]	<i>F F G</i>
[FeedFwd Disturb Time]	<i>F F t G</i>

## [Set 1] P 5 / - Menu

### Access

[Complete settings] → [Generic functions] → [Parameters switching] → [Set 1]

### About This Menu

Making an entry in this menu opens a settings window containing the selected parameters in the order in which they were selected.

## [Set 2] P 5 2 - Menu

### Access

[Complete settings] → [Generic functions] → [Parameters switching] → [Set 2]

### About This Menu

Identical to [Set 1] P 5 1 - ([see page 595](#)).

## [Set 3] P 5 3 - Menu

### Access

[Complete settings] → [Generic functions] → [Parameters switching] → [Set 3]

### About This Menu

Identical to [Set 1] P 5 1 - ([see page 595](#)).

## Section 7.48

### [Generic functions] - [Stop on prolonged spd]

#### [Stop after speed timeout] $P_r 5 P$ - Menu

##### Access

[Complete settings] → [Generic functions] → [Stop after speed timeout]

##### Sleep/Wake-Up in Speed Control Mode

The drive is in Speed control mode, when PID is not active, typically when:

- PID is not configured (the motor speed setpoint is controlled by an external PLC, for example).
- PID is in manual mode (manual application mode, for example).
- PID is not active because Channel 1 is not selected (forced local mode enabled, for example).

When the drive is used in Speed Control (PID not used or not active), a speed condition is used to switch the application to the sleep state. When the drive is in sleep state, the motor is restarted if the sleep condition disappears.

This function avoids prolonged operation at low speeds when neither useful nor compliant with the system constraints. It stops the motor after a period of operation at reduced speed. This time and speed can be adjusted.

In Speed control mode, Sleep/Wake-up is managed according to the following rules:

- The motor is stopped when [Pre-Ramp Ref Freq]  $F_{rH}$  and [Output frequency]  $r_{FR}$  become and stay lower than [Low speed]  $LSP + [Sleep Offset Thres.] SLE$  during [Low Speed Timeout]  $ELS$ .
- The motor is restarted when [Pre-Ramp Ref Freq]  $F_{rH} > [Low speed] LSP + [Sleep Offset Thres.] SLE$ .

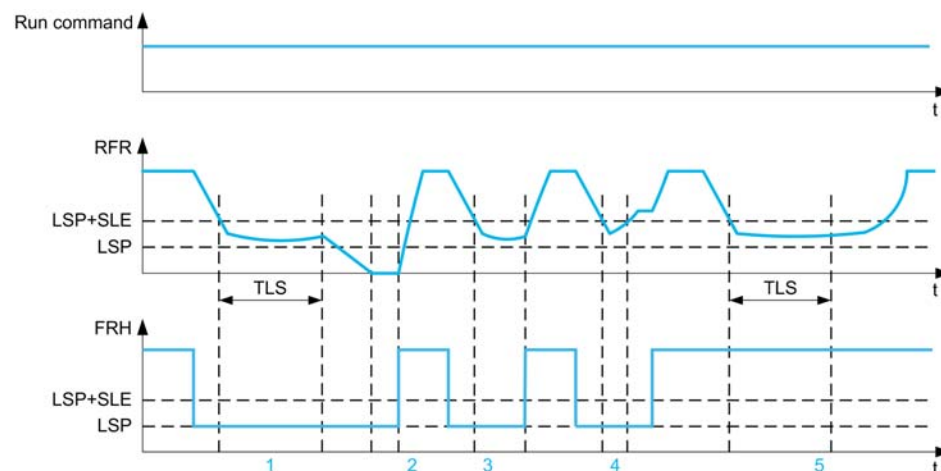

- 1 Nominal [Low Speed Timeout]  $ELS$  function action: after [Low Speed Timeout]  $ELS$  time, the motor is stopped according to the current deceleration ramp
- 2 [Pre-Ramp Ref Freq]  $F_{rH}$  becomes greater than [Low speed]  $LSP + [Sleep Offset Thres.] SLE$  and run order still present [Low Speed Timeout]  $ELS$  function is deactivated
- 3 [Low Speed Timeout]  $ELS$  function is not activated because [Pre-Ramp Ref Freq]  $F_{rH}$  becomes greater than [Low speed]  $LSP + [Sleep Offset Thres.] SLE$  before [Low Speed Timeout]  $ELS$  has expired
- 4 [Low Speed Timeout]  $ELS$  function is not activated because [Output frequency]  $r_{FR}$  becomes greater than [Low speed]  $LSP + [Sleep Offset Thres.] SLE$  before [Low Speed Timeout]  $ELS$  has expired
- 5 [Low Speed Timeout]  $ELS$  function is not activated because [Pre-Ramp Ref Freq]  $F_{rH}$  stays greater than [Low speed]  $LSP + [Sleep Offset Thres.] SLE$

**[Low Speed Timeout] L L S**

Time limited speed.

Setting 	Description
0.0...999.9 s	Setting range <b>Factory setting:</b> 0.0 s

**[Sleep Offset Thres.] S L E**

Sleep offset threshold.

Adjustable restart threshold (offset) following a stop after prolonged operation at **[Low speed] L S P + [Sleep Offset Thres.] S L E**, in Hz. The motor restarts if the reference rises above (LSP + SLE) and if a run command is still present.

Setting 	Description
1.0... <b>[Max Frequency] L F r</b>	Setting range <b>Factory setting:</b> 1.0 Hz

---

## Section 7.49

### [Generic monitoring]

---

#### What Is in This Section?

This section contains the following topics:

Topic	Page
[Process underload] <i>u L d</i> - Menu	600
[Process overload] <i>o L d</i> - Menu	602
[Stall monitoring] <i>S E P r</i> - Menu	604
[Pump thermal monit] <i>t P P</i> - Menu	605

**[Process underload]  $\cup L d$  - Menu**

**Access**

[Complete settings] → [Generic monitoring] → [Process underload]

**Process Underload Detected Error**

A process underload is detected when the next event occurs and remains pending for a minimum time [Unld T. Del. Detect]  $\cup L E$ , which is configurable:

- The motor is in steady state and the torque is below the set underload limit ([Unld.Thr.0.Speed]  $L \cup L$ , [Unld.Thr.Nom.Speed]  $L \cup n$ , [Unld. FreqThr. Det.]  $r \Pi \cup d$  parameters).
- The motor is in steady state when the offset between the frequency reference and motor frequency falls below the configurable threshold [Hysteresis Freq]  $S r b$ .

Between zero frequency and the rated frequency, the curve reflects the following equation: Torque =  $L \cup L + (L \cup n - L \cup L) \times (\text{frequency})^2 / (\text{rated frequency})^2$  The underload function is not active for frequencies below  $r \Pi \cup d$ .

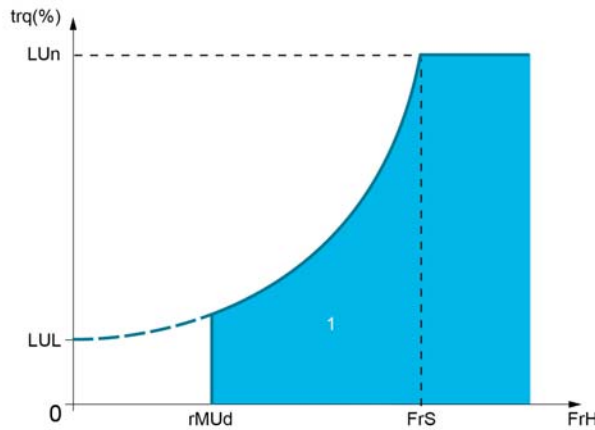

1 Underload zone.

A relay or a digital output can be assigned to the signaling of this detected error in the [Input/Output]  $i o$  - , [I/O assignment]  $i o R 5$  - menus.

**[Unld T. Del. Detect]  $\cup L E$**

Underload detection time delay.

A value of 0 deactivates the function and makes the other parameters inaccessible.

Setting	Description
0...100 s	Setting range Factory setting: 0 s

**[Unld.Thr.Nom.Speed]  $L \cup n$  ★**

Underload threshold at nominal motor speed [Nominal Motor Freq]  $F r S$ , as a % of the rated motor torque.

This parameter can be accessed if [Unld T. Del. Detect]  $\cup L E$  is not set to 0.

Setting ( )	Description
20...100%	Setting range Factory setting: 60%



**[Unld.Thr.0.Speed] L u L ★**

Underload threshold at zero frequency as a % of the rated motor torque.

This parameter can be accessed if **[Unld T. Del. Detect] u L t** is not set to 0.

Setting ( )	Description
0...[Unld.Thr.Nom.Speed] L u n	Setting range <b>Factory setting:</b> 0%

**[Unld. FreqThr. Det.] r n u d ★**

Minimum frequency underload detection threshold.

This parameter can be accessed if **[Unld T. Del. Detect] u L t** is not set to 0

Setting ( )	Description
0.0...500.0 Hz	Setting range <b>Factory setting:</b> 0.0 Hz

**[Hysteresis Freq] S r b ★**

Maximum deviation between the frequency reference and the motor frequency, which defines a steady state operation.

This parameter can be accessed if **[Unld T. Del. Detect] u L t** or **[Ovld Time Detect.] t o L** is not set to 0.

Setting ( )	Description
0.3...500.0 Hz	Setting range <b>Factory setting:</b> 0.3 Hz

**[Underload Mangmt.] u d L ★**

Underload Management.

Behavior on switching to underload detection.

This parameter can be accessed if **[Unld T. Del. Detect] u L t** is not set to 0.

Setting	Code / Value	Description
<b>[Ignore]</b>	n o	Detected error ignored
<b>[Freewheel]</b>	y e s	Freewheel stop <b>Factory setting</b>
<b>[Ramp stop]</b>	r n p	Stop on ramp
<b>[Fast stop]</b>	f s t	Fast stop

**[Underload T.B.Rest.] F t u ★**

Minimum time permitted between an underload being detected and any automatic restart.

To allow an automatic restart, the value of **[Fault Reset Time] t R r** must exceed this parameter by at least 1 minute.

This parameter can be accessed if **[Underload Mangmt.] u d L** is not set to **[Ignore] n o**.

Setting ( )	Description
0...6 min	Setting range <b>Factory setting:</b> 0 min

**[Process overload] *o L d* - Menu**

**Access**

[Complete settings] → [Generic monitoring] → [Process overload]

**About This Menu**

A process overload error is detected when the next event occurs and remains pending for a minimum time **[Ovld Time Detect.] *t o L***, which is configurable:

- The drive is in current limitation mode.
- The motor is in steady state and the current is above the set overload threshold **[Ovld Detection Thr.] *L o C***.

The motor is in steady state when the offset between the frequency reference and motor frequency falls below the configurable threshold **[Hysteresis Freq] *S r b***.

A relay or a digital output can be assigned to the signaling of this detected error.

**[Ovld Time Detect.] *t o L***

Overload reaction time.

A value of 0 deactivates the function and makes the other parameters inaccessible.

Setting	Description
0...100 s	Setting range <b>Factory setting:</b> 0 s

**[Ovld Detection Thr.] *L o C* ★**

Overload threshold.

Overload detection threshold, as a % of the rated motor current **[Nom Motor Current] *n C r***. This value must be less than the limit current in order for the function to work.

This parameter can be accessed if **[Ovld Time Detect.] *t o L*** is not set to 0.

Setting ( )	Description
70...150%	Setting range <b>Factory setting:</b> 110%

**[Hysteresis Freq] *S r b* ★**

Hysteresis for steady state.

Maximum deviation between the frequency reference and the motor frequency, which defines a steady state operation.

This parameter can be accessed if **[Ovld Time Detect.] *t o L*** or **[Unld T. Del. Detect.] *u L t*** is not set to 0.

Setting ( )	Description
0.3...500.0 Hz	Setting range <b>Factory setting:</b> 0.3 Hz

**[Ovld.Proces.Mngmt] *o d L* ★**

Behavior on switching to overload detection.

This parameter can be accessed if **[Ovld Time Detect.] *t o L*** is not set to 0.

Setting	Code / Value	Description
<b>[Ignore]</b>	<i>n o</i>	Detected error ignored
<b>[Freewheel]</b>	<i>Y E S</i>	Freewheel stop <b>Factory setting</b>
<b>[Ramp stop]</b>	<i>r P P</i>	Stop on ramp
<b>[Fast stop]</b>	<i>F S t</i>	Fast stop

**[Overload T.B.Rest.] F E o ★**

Minimum time permitted between an overload being detected and any automatic restart.

In order to allow an automatic restart, the value of **[Fault Reset Time] E R r** must exceed this parameter by at least 1 minute.

This parameter can be accessed if **[Ovld Time Detect.] E o L** or **[Unld T. Del. Detect.] u L E** is not set to 0.

Setting ( )	Description
0...6 min	Setting range <b>Factory setting:</b> 0 min

## [Stall monitoring] 5 Ł P r - Menu

### Access

[Complete settings] → [Generic monitoring] → [Stall monitoring]

### About This Menu

This function helps to prevent a motor overload by monitoring the motor current and the speed rise time.

A stalling condition is when:

- An output frequency is smaller than the stalling frequency [**Stall Frequency**] 5 Ł P 3
- And an output current is higher than the stalling current [**Stall Current**] 5 Ł P 2
- During a time longer than the stalling time [**Stall Max Time**] 5 Ł P 1

When a stalling condition occurs, an [**Motor Stall Error**] 5 Ł F error is triggered.

### [Stall Monitoring] 5 Ł P C

Stall monitoring activation.

Setting	Code / Value	Description
[No]	n o	Function disabled <b>Factory setting</b>
[Yes]	y e s	Function enabled

### [Stall Max Time] 5 Ł P 1 ★

Motor stall maximum time.

This parameter can be accessed if [**Stall Monitoring**] 5 Ł P C is not set to [**No**] n o.

Setting ( )	Description
0.0...200 s	Setting range <b>Factory setting:</b> 60.0 s

### [Stall Current] 5 Ł P 2 ★

Stall monitoring current level.

This parameter can be accessed if [**Stall Monitoring**] 5 Ł P C is not set to [**No**] n o.

Setting ( )	Description
0.0...150.0%	Setting range <b>Factory setting:</b> 150.0%

### [Stall Frequency] 5 Ł P 3 ★

Stall monitoring frequency level.

This parameter can be accessed if [**Stall Monitoring**] 5 Ł P C is not set to [**No**] n o.

Setting ( )	Description
0.0...[ <b>Max Frequency</b> ] Ł F r	Setting range <b>Factory setting:</b> 2.0 Hz

## [Pump thermal monit] *ε P P* - Menu

### Access

[Complete settings] → [Generic monitoring] → [Pump therm monit]

### About This Menu

Identical to Pump Thermal Monitoring (*see page 465*).

## Section 7.50

### [Input/Output] - [I/O assignment]

#### What Is in This Section?

This section contains the following topics:

Topic	Page
[DI1 assignment] L 1 A - Menu	607
[DI2 assignment] L 2 A - Menu	609
[DI3 assignment] L 3 A - Menu	610
[DI4 assignment] L 4 A - Menu	611
[DI5 assignment] L 5 A - Menu	612
[DI6 assignment] L 6 A - Menu	613
[DI11 assignment] L 11 A - Menu	614
[DI12 assignment] L 12 A - Menu	615
[DI13 assignment] L 13 A - Menu	616
[DI14 assignment] L 14 A - Menu	617
[DI15 assignment] L 15 A - Menu	618
[DI16 assignment] L 16 A - Menu	619
[DI5 Pulse Input Assign] P 5 A - Menu	620
[DI6 Pulse Input Assign] P 6 A - Menu	621
[AI1 assignment] A 1 A - Menu	622
[AI2 assignment] A 2 A - Menu	623
[AI3 assignment] A 3 A - Menu	624
[AI4 assignment] A 4 A - Menu	625
[AI5 assignment] A 5 A - Menu	626
[AU1A assignment] A 1 A - Menu	627

**[DI1 assignment] L I R - Menu****Access**

[Complete settings] → [Input/Output] → [I/O assignment] → [DI1 assignment]

**[DI1 Low Assignment] L I L**

DI1 low assignment.

Setting	Code / Value	Description
[No]	<i>n o</i>	Not assigned
[Freewheel stop]	<i>n S t</i>	Freewheel stop
[Fast stop]	<i>F S t</i>	Fast stop
[External Error]	<i>E t F</i>	External error
[Drive Lock]	<i>L E S</i>	Drive lock assignment
[Switch source]	<i>o P P W</i>	Outlet pressure switch select
[Switch Source]	<i>S L P W</i>	Select an external condition to enter in sleep mode (for example. Flow switch)
[Source Activation]	<i>P F E C</i>	Pipe fill enable condition
[Source Selection]	<i>J E t C</i>	External Anti-Jam trigger condition
[Switch Select]	<i>d r Y W</i>	Dry run no flow switch selection
[Switch Selection]	<i>P L F W</i>	Pump low flow no flow switch selection

**[DI1 High Assignment] L I H**

DI1 high assignment.

Setting	Code / Value	Description
[No]	<i>n o</i>	Not assigned
[Run]	<i>r u n</i>	Run enable
[Forward]	<i>F r d</i>	Forward operation
[Reverse]	<i>r r S</i>	Reverse operation
[Ramp switching]	<i>r P S</i>	Ramp switching
[+Speed]	<i>u S P</i>	+ speed
[- speed]	<i>d S P</i>	- Speed
[2 preset speeds]	<i>P S 2</i>	2 preset speeds
[4 preset speeds]	<i>P S 4</i>	4 preset speeds
[8 preset speeds]	<i>P S 8</i>	8 preset speeds
[Ref. 2 switching]	<i>r F C</i>	Reference switching
[Freewheel stop]	<i>n S t</i>	Freewheel stop
[DC injection]	<i>d C i</i>	Injection DC stop
[Fast stop]	<i>F S t</i>	Fast stop
[Forced local]	<i>F L o</i>	Forced local mode
[Fault reset]	<i>r S F</i>	Fault reset
[Autotuning Assign]	<i>t u L</i>	Autotuning assignment
[Auto / manual]	<i>P R u</i>	PID auto-manu
[PID integral reset]	<i>P i S</i>	Integral shunting PID
[2 preset PID ref.]	<i>P r 2</i>	2 preset PID references
[4 preset PID ref.]	<i>P r 4</i>	4 preset PID references
[Torque limitation]	<i>t L R</i>	Permanent torque limitation
[External fault]	<i>E t F</i>	External fault
[2 parameter sets]	<i>C H R 1</i>	Parameter switching 1
[3 parameter sets]	<i>C H R 2</i>	Parameter switching 2
[Cmd switching]	<i>C C S</i>	Command channel switching

Setting	Code / Value	Description
[ErrorDetect Disable]	<i>i n H</i>	Error detection disable
[16 preset speeds]	<i>P S 1 6</i>	16 preset speeds
[Ref 1B switching]	<i>r C b</i>	Reference channel switching (1 to 1B)
[Drive Lock]	<i>L E S</i>	Drive lock assignment
[ProductRestart Assign]	<i>r P R</i>	Restart product
[Idle]	<i>i d L S</i>	Stop and go : idle mode enable condition
[R1]...[R3]	<i>r 1...r 3</i>	Relay output R1...R3
[R4]...[R6]	<i>r 4...r 6</i>	Relay output R4...R6, if VW3A3204 relay output option module has been inserted
[Analog output DQ11]...[Analog output DQ12]	<i>d o 1 1...d o 1 2</i>	Analog / digital output DO11...DO12, if VW3A3203 I/O extension module has been inserted
[Preset spd2]	<i>F P S 1</i>	Function key preset speed 1 assignment
[Preset spd3]	<i>F P S 2</i>	Function key preset speed 2 assignment
[PID ref. 2]	<i>F P r 1</i>	Function key preset PI 1 assignment
[PID ref. 3]	<i>F P r 2</i>	Function key preset PI 2 assignment
[+Speed]	<i>F u S P</i>	Function key faster assignment
[-Speed]	<i>F d S P</i>	Function key slower assignment
[T/K]	<i>F t</i>	Function key bumpless assignment
[VSP]	<i>v S P</i>	Variable speed pump selection
[Switch source]	<i>o P P W</i>	Outlet pressure switch select
[Switch Source]	<i>S L P W</i>	Select an external condition to enter in sleep mode (for example. Flow switch)
[Source Activation]	<i>P F E C</i>	Pipe fill enable condition
[Source Selection]	<i>J E t C</i>	External Anti-Jam trigger condition
[Switch Select]	<i>d r y W</i>	Dry run no flow switch selection
[Switch Selection]	<i>P L F W</i>	Pump low flow no flow switch selection



---

## [DI2 assignment] *L 2 R* - Menu

### Access

[Complete settings] → [Input/Output] → [I/O assignment] → [DI2 assignment]

### About This Menu

Identical to [DI1 assignment] *L 1 R* - menu (*see page 607*).

### [DI2 Low Assignment] *L 2 L*

DI2 low assignment.

### [DI2 High Assignment] *L 2 H*

DI2 high assignment.

## [DI3 assignment] L 3 R - Menu

### Access

[Complete settings] → [Input/Output] → [I/O assignment] → [DI3 assignment]

### About This Menu

Identical to [DI1 assignment] L 1 R - menu (*see page 607*).

### [DI3 Low Assignment] L 3 L

DI3 low assignment.

### [DI3 High Assignment] L 3 H

DI3 high assignment.

## [DI4 assignment] L 4 R - Menu

### Access

[Complete settings] → [Input/Output] → [I/O assignment] → [DI4 assignment]

### About This Menu

Identical to [DI1 assignment] L 1 R - menu (*see page 607*).

### [DI4 Low Assignment] L 4 L

DI4 low assignment.

### [DI4 High Assignment] L 4 H

DI4 high assignment.

## **[DI5 assignment] L 5 R - Menu**

### **Access**

**[Complete settings] → [Input/Output] → [I/O assignment] → [DI5 assignment]**

### **About This Menu**

Identical to **[DI1 assignment] L 1 R** - menu (*see page 607*).

### **[DI5 Low Assignment] L 5 L**

DI5 low assignment.

### **[DI5 High Assignment] L 5 H**

DI5 high assignment.

---

## [DI6 assignment] L B R - Menu

### Access

[Complete settings] → [Input/Output] → [I/O assignment] → [DI6 assignment]

### About This Menu

Identical to [DI1 assignment] L I R - menu (*see page 607*).

### [DI6 Low Assignment] L B L

DI6 low assignment.

### [DI6 High Assignment] L B H

DI6 high assignment.

## [DI11 assignment] L I IR - Menu

### Access

[Complete settings] → [Input/Output] → [I/O assignment] → [DI11 assignment]

### About This Menu

Identical to [DI1 assignment] L I R - menu (*see page 607*).

Following parameters can be accessed if VW3A3203 relay output option module has been inserted.

### [DI11 Low Assignment] L I IL ★

DI11 low assignment.

### [DI11 High Assignment] L I IH ★

DI11 high assignment.

## [DI12 assignment] L 12R - Menu

### Access

[Complete settings] → [Input/Output] → [I/O assignment] → [DI12 assignment]

### About This Menu

Identical to [DI1 assignment] L 1R - menu (*see page 607*).

Following parameters can be accessed if VW3A3203 relay output option module has been inserted.

### [DI12 Low Assignment] L 12L ★

DI12 low assignment.

### [DI12 High Assignment] L 12H ★

DI12 high assignment.

## [DI13 assignment] L I 3 R - Menu

### Access

[Complete settings] → [Input/Output] → [I/O assignment] → [DI13 assignment]

### About This Menu

Identical to [DI1 assignment] L I R - menu (*see page 607*).

Following parameters can be accessed if VW3A3203 relay output option module has been inserted.

### [DI13 Low Assignment] L I 3 L ★

DI13 low assignment.

### [DI13 High Assignment] L I 3 H ★

DI13 high assignment.



---

## [DI14 assignment] L 14R - Menu

### Access

[Complete settings] → [Input/Output] → [I/O assignment] → [DI14 assignment]

### About This Menu

Identical to [DI1 assignment] L 1R - menu (*see page 607*).

Following parameters can be accessed if VW3A3203 relay output option module has been inserted.

### [DI14 Low Assignment] L 14L ★

DI14 low assignment.

### [DI14 High Assignment] L 14H ★

DI14 high assignment.

## [DI15 assignment] L 15 R - Menu

### Access

[Complete settings] → [Input/Output] → [I/O assignment] → [DI15 assignment]

### About This Menu

Identical to [DI1 assignment] L 1 R - menu (*see page 607*).

Following parameters can be accessed if VW3A3203 relay output option module has been inserted.

### [DI15 Low Assignment] L 15 L ★

DI15 low assignment.

### [DI15 High Assignment] L 15 H ★

DI15 high assignment.

---

## [DI16 assignment] L I B R - Menu

### Access

[Complete settings] → [Input/Output] → [I/O assignment] → [DI16 assignment]

### About This Menu

Identical to [DI1 assignment] L I R - menu (*see page 607*).

Following parameters can be accessed if VW3A3203 relay output option module has been inserted.

### [DI16 Low Assignment] L I B L ★

DI16 low assignment.

### [DI16 High Assignment] L I B H ★

DI16 high assignment.

## [DI5 Pulse Input Assign] P , 5 R - Menu

### Access

[Complete settings] → [Input/Output] → [I/O assignment] → [DI5 Pulse Input Assign]

### About This Menu

Following parameters can be accessed on the Graphic Display Terminal by pressing the OK key on the [DI5 Frequency Measured] P F C 5 parameter.

### [DI5 Pulse Input Assign] P , 5 R

DI5 pulse input assignment.

It displays all the functions associated with the pulse input in order to verify, for example, for compatibility problems.

If no functions have been assigned, [No] n o is displayed.

Setting	Code / Value	Description
[No]	n o	Not assigned <b>Factory Setting</b>
[AQ1 assignment]	A o 1	Analog output AQ1
[AQ2 assignment]	A o 2	Analog output AQ2
[Ref Freq Channel 1]	F r 1	Reference frequency channel 1
[Ref Freq Channel 2]	F r 2	Reference frequency channel 2
[Ref Frequency 2 Summing]	S R 2	Reference frequency 2 summing
[PID Feedback]	P , F	PI controller feedback
[Subtract Ref Freq 2]	d R 2	Subtract reference frequency 2
[Manual PID Ref.]	P , π	Manual speed reference of the PID controller (auto-man)
[PID Ref Frequency]	F P ,	PID reference frequency
[Ref Frequency 3 Summing]	S R 3	Reference frequency 3 summing
[Ref Frequency 1B]	F r 1 b	Reference frequency 1B
[Subtract Ref Freq 2]	d R 3	Subtract reference frequency 3
[Forced local]	F L o C	Forced local reference source1
[Ref Frequency 2 multiplier]	π R 2	Reference frequency 2 multiplier
[Ref Frequency 3 multiplier]	π R 3	Reference frequency 3 multiplier
[Virtual AI1 Channel]	A , C 1	Virtual AI1 channel selector function
[InletPres Assign]	P S 1 R	Select the source of inlet pressure sensor
[OutletPres Assign]	P S 2 R	Select the source of outlet pressure sensor
[Inst Flow Assign]	F S 1 R	Select the source of installation flow sensor
[Pump Flow Assign]	F S 2 R	Select the source of pump flow sensor

## [DI6 Pulse Input Assign] P , 5 R - Menu

### Access

[Complete settings] → [Input/Output] → [I/O assignment] → [Pulse Input DI6 Assign]

### About This Menu

Identical to [DI5 Pulse Input Assign] P , 5 R - ([see page 131](#)).

Following parameters can be accessed on the Graphic Display Terminal by pressing the OK key on the [DI6 Frequency Measured] P F L 5 parameter.

### [Pulse Input DI6 Assign] P , 5 R

Pulse Input DI6 Assignment.

**[AI1 assignment] *R* , *IR* - Menu****Access**

[Complete settings] → [Input/Output] → [I/O assignment] → [AI1 assignment]

**[AI1 Assignment] *R* , *IR***

Analog input AI1 functions assignment.

Read-only parameter, cannot be configured. It displays all the functions associated with input AI1 in order to verify, for example, for compatibility problems.

If no functions have been assigned, **[No]** *n o* is displayed.

Setting	Code / Value	Description
[No]	<i>n o</i>	Not assigned
[AQ1 assignment]	<i>A o 1</i>	Analog output AQ1
[AQ2 assignment]	<i>A o 2</i>	Analog output AQ2
[Ref Freq Channel 1]	<i>F r 1</i>	Reference frequency channel 1 <b>Factory Setting</b>
[Ref Freq Channel 2]	<i>F r 2</i>	Reference frequency channel 2
[Ref Frequency 2 Summing]	<i>S R 2</i>	Reference frequency 2 summing
[PID Feedback]	<i>P , F</i>	PI controller feedback
[Subtract Ref Freq 2]	<i>d R 2</i>	Subtract reference frequency 2
[Manual PID Ref.]	<i>P , Π</i>	Manual speed reference of the PID controller (auto-man)
[PID Ref Frequency]	<i>F P ,</i>	PID reference frequency
[Ref Frequency 3 Summing]	<i>S R 3</i>	Reference frequency 3 summing
[Ref Frequency 1B]	<i>F r 1 b</i>	Reference frequency 1B
[Subtract Ref Freq 2]	<i>d R 3</i>	Subtract reference frequency 3
[Forced local]	<i>F L o C</i>	Forced local reference source1
[Ref Frequency 2 multiplier]	<i>Π R 2</i>	Reference frequency 2 multiplier
[Ref Frequency 3 multiplier]	<i>Π R 3</i>	Reference frequency 3 multiplier
[Virtual AI1 Channel]	<i>A , C 1</i>	Virtual AI1 channel selector function
[InletPres Assign]	<i>P S 1 R</i>	Select the source of inlet pressure sensor
[OutletPres Assign]	<i>P S 2 R</i>	Select the source of outlet pressure sensor
[Inst Flow Assign]	<i>F S 1 R</i>	Select the source of installation flow sensor
[Pump Flow Assign]	<i>F S 2 R</i>	Select the source of pump flow sensor

---

## [AI2 assignment] *R* , *2 R* - Menu

### Access

[Complete settings] → [Input/Output] → [I/O assignment] → [AI2 assignment]

### About This Menu

Identical to [AI1 assignment] *R* , *1 R* - menu (*see page 622*).

### [AI2 Assignment] *R* , *2 R*

AI2 assignment.

## [AI3 assignment] $R$ , $\exists R$ - Menu

### Access

[Complete settings] → [Input/Output] → [I/O assignment] → [AI3 assignment]

### About This Menu

Identical to [AI1 assignment]  $R$  ,  $I R$  - menu (*see page 622*).

### [AI3 assignment] $R$ , $\exists R$

AI3 assignment.



## [AI4 assignment] *R* , *4R* - Menu

### Access

[Complete settings] → [Input/Output] → [I/O assignment] → [AI4 assignment]

### About This Menu

Identical to [AI1 assignment] *R* , *1R* - menu (*see page 622*).

### [AI4 Assignment] *R* , *4R* ★

AI4 assignment.

This parameter can be accessed if VW3A3203 relay output option module has been inserted.

## [AI5 assignment] *R* , *5 R* - Menu

### Access

[Complete settings] → [Input/Output] → [I/O assignment] → [AI5 assignment]

### About This Menu

Identical to [AI1 assignment] *R* , *1 R* - menu (*see page 622*).

### [AI5 Assignment] *R* , *5 R* ★

AI5 assignment.

This parameter can be accessed if VW3A3203 relay output option module has been inserted.

---

## [AU1A assignment] *IR* - Menu

### Access

[Complete settings] → [Input/Output] → [I/O assignment] → [AU1A assignment]

### About This Menu

Identical to [AI1 assignment] *IR* - menu (*see page 622*).

## [AIV1 Assignment] *IR*

Virtual analog input 1 function assignment.

## Section 7.51

### [Input/Output] - [DI/DQ]

#### What Is in This Section?

This section contains the following topics:

Topic	Page
[DI1 Configuration] <i>d , 1</i> - Menu	629
[DI2 Configuration] <i>d , 2</i> - Menu	631
[DI3 Configuration] <i>d , 3</i> - Menu	632
[DI4 Configuration] <i>d , 4</i> - Menu	633
[DI5 Configuration] <i>d , 5</i> - Menu	634
[DI6 Configuration] <i>d , 6</i> - Menu	635
[DI11 Configuration] <i>d , 11</i> - Menu	636
[DI12 Configuration] <i>d , 12</i> - Menu	637
[DI13 Configuration] <i>d , 13</i> - Menu	638
[DI14 Configuration] <i>d , 14</i> - Menu	639
[DI15 Configuration] <i>d , 15</i> - Menu	640
[DI16 Configuration] <i>d , 16</i> - Menu	641
[DI5 Pulse Config] <i>PR , 5</i> - Menu	642
[DI6 Pulse Config] <i>PR , 6</i> - Menu	644
[DQ11 Configuration] <i>d q 11</i> - Menu	645
[DQ12 Configuration] <i>d q 12</i> - Menu	647

**[DI1 Configuration] d , l - Menu****Access**

[Complete settings] → [Input/Output] → [DI/DQ] → [DI1 Configuration]

**[DI1 Low Assignment] L / L**

DI1 low assignment.

Setting	Code / Value	Description
[No]	<i>n o</i>	Not assigned <b>Factory setting</b>
[Run]	<i>r u n</i>	Run enable
[Forward]	<i>F r d</i>	Forward operation
[Reverse]	<i>r r 5</i>	Reverse operation
[Ramp switching]	<i>r P 5</i>	Ramp switching
[+Speed]	<i>u 5 P</i>	+ speed
[- speed]	<i>d 5 P</i>	- Speed
[2 preset speeds]	<i>P 5 2</i>	2 preset speeds
[4 preset speeds]	<i>P 5 4</i>	4 preset speeds
[8 preset speeds]	<i>P 5 8</i>	8 preset speeds
[Ref. 2 switching]	<i>r F C</i>	Reference switching
[Freewheel stop]	<i>n 5 k</i>	Freewheel stop
[DC injection]	<i>d C ,</i>	Injection DC stop
[Fast stop]	<i>F 5 k</i>	Fast stop
[Forced local]	<i>F L o</i>	Forced local mode
[Fault reset]	<i>r 5 F</i>	Fault reset
[Autotuning Assign]	<i>t u L</i>	Autotuning assignment
[Auto / manual]	<i>P R u</i>	Auto / Manual switch
[PID integral reset]	<i>P , 5</i>	Integral shunting PID
[2 preset PID ref.]	<i>P r 2</i>	2 preset PID references
[4 preset PID ref.]	<i>P r 4</i>	4 preset PID references
[Torque limitation]	<i>t L R</i>	Permanent torque limitation
[External Error]	<i>E k F</i>	External error
[2 parameter sets]	<i>C H R 1</i>	Parameter switching 1
[3 parameter sets]	<i>C H R 2</i>	Parameter switching 2
[Cmd switching]	<i>C C 5</i>	Command channel switching
[ErrorDetect Disable]	<i>, n H</i>	Error Detection Disable
[16 preset speeds]	<i>P 5 16</i>	16 preset speeds
[Ref 1B switching]	<i>r C b</i>	Reference channel switching (1 to 1B)
[Drive Lock]	<i>L E 5</i>	Drive lock assignment
[ProductRestart Assign]	<i>r P R</i>	Restart product
[Idle]	<i>, d L 5</i>	Stop and go : idle mode enable condition
[R1]...[R3]	<i>r 1...r 3</i>	Relay output R1...R3
[R4]...[R6]	<i>r 4...r 6</i>	Relay output R4...R6 if VW3A3204 relay output option module has been inserted
[Analog output DQ11]...[Analog output DQ12]	<i>d o 11...d o 12</i>	Analog / digital output DO11...DO12 if VW3A3203 I/O extension module has been inserted
[Preset spd2]	<i>F P 5 1</i>	Function key preset speed 1 assignment
[Preset spd3]	<i>F P 5 2</i>	Function key preset speed 2 assignment
[PID ref. 2]	<i>F P r 1</i>	Function key preset PI 1 assignment
[PID ref. 3]	<i>F P r 2</i>	Function key preset PI 2 assignment
[+Speed]	<i>F u 5 P</i>	Function key faster assignment

Setting	Code / Value	Description
[Speed]	<i>F d S P</i>	Function key slower assignment
[T/K]	<i>F t</i>	Function key bumpless assignment
[VSP]	<i>V S P</i>	Variable speed pump selection
[Switch source]	<i>o P Pw</i>	Outlet pressure switch selects
[Switch Source]	<i>S L Pw</i>	Select an external condition to enter in sleep mode (for example. Flow switch)
[Source Activation]	<i>P F E C</i>	Pipe fill enable condition
[Source Selection]	<i>J E t C</i>	External Anti-Jam trigger condition
[Switch Select]	<i>d r Yw</i>	Dry run no flow switch selection
[Switch Selection]	<i>P L Fw</i>	Pump low flow no flow switch selection

**[DI1 High Assignment] L I H**

DI1 high assignment.

Identical to low assignment.

**[DI1 Delay] L I d**

DI1 delay.

**NOTE:** Commands received via this digital input are processed once the delay time set via this parameter has elapsed.

Setting	Description
0...200 ms	Setting range <b>Factory setting:</b> 0 ms

---

## [DI2 Configuration] *d , 2* - Menu

### Access

[Complete settings] → [Input/Output] → [DI/DQ] → [DI2 Configuration]

### About This Menu

Identical to [DI1 Configuration] *d , 1* - menu (*see page 629*).

### [DI2 Low Assignment] *L 2 L*

DI2 low assignment.

### [DI2 High Assignment] *L 2 H*

DI2 high assignment.

### [DI2 Delay] *L 2 d*

DI2 delay.

## [DI3 Configuration] *d , 3* - Menu

### Access

[Complete settings] → [Input/Output] → [DI/DQ] → [DI3 Configuration]

### About This Menu

Identical to [DI1 Configuration] *d , 1* - menu (*see page 629*).

### [DI3 Low Assignment] *L 3 L*

DI3 low assignment.

### [DI3 High Assignment] *L 3 H*

DI3 high assignment.

### [DI3 Delay] *L 3 d*

DI3 delay.



---

## [DI4 Configuration] *d , 4* - Menu

### Access

[Complete settings] → [Input/Output] → [DI/DQ] → [DI4 Configuration]

### About This Menu

Identical to [DI1 Configuration] *d , 1* - menu (*see page 629*).

### [DI4 Low Assignment] *L 4 L*

DI4 low assignment.

### [DI4 High Assignment] *L 4 H*

DI4 high assignment.

### [DI4 Delay] *L 4 d*

DI4 delay.

## [DI5 Configuration] *d* , *5* - Menu

### Access

[Complete settings] → [Input/Output] → [DI/DQ] → [DI5 Configuration]

### About This Menu

Identical to [DI1 Configuration] *d* , *1* - menu (*see page 629*).

### [DI5 Low Assignment] *L 5 L*

DI5 low assignment.

### [DI5 High Assignment] *L 5 H*

DI5 high assignment.

### [DI5 Delay] *L 5 d*

DI5 delay.

---

## [DI6 Configuration] *d* , *Б* - Menu

### Access

[Complete settings] → [Input/Output] → [DI/DQ] → [DI6 Configuration]

### About This Menu

Identical to [DI1 Configuration] *d* , *Г* - menu (*see page 629*).

### [DI6 Low Assignment] *Л Б Л*

DI6 low assignment.

### [DI6 High Assignment] *Л Б H*

DI6 high assignment.

### [DI6 Delay] *Л Б d*

DI6 delay.

## [DI11 Configuration] *d , / / - Menu*

### Access

[Complete settings] → [Input/Output] → [DI/DQ] → [DI11 Configuration]

### About This Menu

Identical to [DI1 Configuration] *d , / / - menu* (*see page 629*).

### [DI11 Low Assignment] *L / / L ★*

DI11 low assignment.

### [DI11 High Assignment] *L / / H ★*

DI11 high assignment.

### [DI11 Delay] *L / / d ★*

DI11 delay.

## [DI12 Configuration] *d , I2* - Menu

### Access

[Complete settings] → [Input/Output] → [DI/DQ] → [DI12 Configuration]

### About This Menu

Identical to [DI1 Configuration] *d , I* - menu (*see page 629*).

### [DI12 Low Assignment] *L I2L* ★

DI12 low assignment.

### [DI12 High Assignment] *L I2H* ★

DI12 high assignment.

### [DI12 Delay] *L I2d* ★

DI12 delay.

## [DI13 Configuration] *d , l 3* - Menu

### Access

[Complete settings] → [Input/Output] → [DI/DQ] → [DI13 Configuration]

### About This Menu

Identical to [DI1 Configuration] *d , l* - menu (*see page 629*).

### [DI13 Low Assignment] *L l 3 L* ★

DI13 low assignment.

### [DI13 High Assignment] *L l 3 H* ★

DI13 high assignment.

### [DI13 Delay] *L l 3 d* ★

DI13 delay.

## [DI14 Configuration] *d , 14* - Menu

### Access

[Complete settings] → [Input/Output] → [DI/DQ] → [DI14 Configuration]

### About This Menu

Identical to [DI1 Configuration] *d , 1* - menu (*see page 629*).

### [DI14 Low Assignment] *L 14L* ★

DI14 low assignment.

### [DI14 High Assignment] *L 14H* ★

DI14 high assignment.

### [DI14 Delay] *L 14d* ★

DI14 delay.

## [DI15 Configuration] *d , I 5* - Menu

### Access

[Complete settings] → [Input/Output] → [DI/DQ] → [DI15 Configuration]

### About This Menu

Identical to [DI1 Configuration] *d , I* - menu (*see page 629*).

### [DI15 Low Assignment] *L I 5 L* ★

DI15 low assignment.

### [DI15 High Assignment] *L I 5 H* ★

DI15 high assignment.

### [DI15 Delay] *L I 5 d* ★

DI15 delay.



## [DI16 Configuration] *d , I B* - Menu

### Access

[Complete settings] → [Input/Output] → [DI/DQ] → [DI16 Configuration]

### About This Menu

Identical to [DI1 Configuration] *d , I* - menu (*see page 629*).

### [DI16 Low Assignment] *L I B L* ★

DI16 low assignment.

### [DI16 High Assignment] *L I B H* ★

DI16 high assignment.

### [DI16 Delay] *L I B d* ★

DI16 delay.

## [DI5 Pulse Config] P R , 5 - Menu

### Access

[Complete settings] → [Input/Output] → [DI/DQ] → [DI5 Pulse Config]

### About This Menu

Following parameters can be accessed on the Graphic Display Terminal by pressing the **OK** key on the [DI5 Frequency Measured] P F C 5 parameter.

### [DI5 Pulse Input Assign] P , 5 R

Di5 pulse input assignment.

It displays all the functions associated with the pulse input in order to verify, for example, for compatibility problems.

If no functions have been assigned, [No] n o is displayed.

Setting	Code / Value	Description
[No]	n o	Not assigned <b>Factory Setting</b>
[AQ1 assignment]	R o 1	Analog output AQ1
[AQ2 assignment]	R o 2	Analog output AQ2
[Ref Freq Channel 1]	F r 1	Reference frequency channel 1
[Ref Freq Channel 2]	F r 2	Reference frequency channel 2
[Ref Frequency 2 Summing]	S R 2	Reference frequency 2 summing
[PID Feedback]	P , F	PI controller feedback
[Subtract Ref Freq 2]	d R 2	Subtract reference frequency 2
[Manual PID Ref.]	P , n	Manual speed reference of the PID controller (auto-man)
[PID Ref Frequency]	F P ,	PID reference frequency
[Ref Frequency 3 Summing]	S R 3	Reference frequency 3 summing
[Ref Frequency 1B]	F r 1 b	Reference frequency 1B
[Subtract Ref Freq 2]	d R 3	Subtract reference frequency 3
[Forced local]	F L o C	Forced local reference source1
[Ref Frequency 2 multiplier]	n R 2	Reference frequency 2 multiplier
[Ref Frequency 3 multiplier]	n R 3	Reference frequency 3 multiplier
[Virtual AI1 Channel]	R , C 1	Virtual AI1 channel selector function
[InletPres Assign]	P 5 1 R	Select the source of inlet pressure sensor
[OutletPres Assign]	P 5 2 R	Select the source of outlet pressure sensor
[Inst Flow Assign]	F 5 1 R	Select the source of installation flow sensor
[Pump Flow Assign]	F 5 2 R	Select the source of pump flow sensor

### [DI5 PulseInput Low Freq] P , L 5

DI5 pulse input low frequency.

Pulse input scaling parameter of 0% in Hz x 10 unit.

Setting	Description
0.00...30000.00 Hz	Setting range <b>Factory setting:</b> 0.00 Hz

**[DI5 PulseInput High Freq] P , H 5**

DI5 pulse input high frequency.

Pulse input scaling parameter of 100% in Hz x 10 unit.

Setting	Description
0.00...30.00 kHz	Setting range <b>Factory setting:</b> 30.00 kHz

**[DI5 Frequency Filter] P F , 5**

Interference filtering pulse input cut-off time of the low-filter.

Setting	Description
0...1,000 ms	Setting range <b>Factory setting:</b> 0 ms

## [DI6 Pulse Config] P R , 6 - Menu

### Access

[Complete settings] → [Input/Output] → [DI/DQ] → [DI6 Pulse Config]

### About This Menu

Following parameters can be accessed on the Graphic Display Terminal by pressing the **OK** key on the [DI6 Frequency Measured] P F 6 parameter.

### [DI6 Pulse Input Assign] P , 6 R

Filtered customer pulse input frequency reference.

Identical to [DI5 Pulse Input Assign] P , 5 R (see page 131).

### [DI6 PulseInput Low Freq] P , L 6

DI6 pulse input low frequency.

Identical to [DI5 PulseInput Low Freq] P , L 5 (see page 131).

### [DI6 PulseInput High Freq] P , H 6

DI6 pulse input high frequency.

Identical to [DI5 PulseInput High Freq] P , H 5 (see page 132).

### [DI6 Frequency Filter] P F , 6

Interference filtering pulse input cut-off time of the low-filter.

Identical to [DI5 Frequency Filter] P F , 5 (see page 132).

## [DQ11 Configuration] *d o l l* - Menu

### Access

[Complete settings] → [Input/Output] → [DI/DQ] → [DQ11 Configuration]

### About This Menu

Following parameters can be accessed if VW3A3203 I/O extension module has been inserted.

### [DQ11 Assignment] *d o l l* ★

Digital output 11 assignment.

Identical to [R1 Assignment] *r l* (see page 666) in addition to:

Setting	Code / Value	Description
[Mains Contactor]	<i>L L C</i>	Mains contactor control
[Jockey]	<i>J o c k e y</i>	Jockey
[Priming]	<i>P r i m</i>	Priming
[Pump 1 Cmd]	<i>П P o 1</i>	Pump 1 command
[Pump 2 Cmd]	<i>П P o 2</i>	Pump 2 command
[Pump 3 Cmd]	<i>П P o 3</i>	Pump 3 command
[Pump 4 Cmd]	<i>П P o 4</i>	Pump 4 command
[Pump 5 Cmd]	<i>П P o 5</i>	Pump 5 command
[Pump 6 Cmd]	<i>П P o 6</i>	Pump 6 command

### [DQ11 actv delay] *d l l d* ★

DO11 activation delay time.

The delay cannot be set for the [Operating State "Fault"] *F L E* and [Mains Contactor] *L L C* assignments, and remains at 0.

The change in state only takes effect once the configured time has elapsed when the information becomes true.

Setting	Description
0...60,000 ms	Setting range 0...9,999 ms then 10.00...60.00 s on the Graphic Display Terminal <b>Factory setting:</b> 0 ms

### [DQ11 status] *d l l s* ★

DO11 status (output active level).

Setting	Code / Value	Description
[1]	<i>P o 5</i>	State 1 when the information is true <b>Factory Setting</b>
[0]	<i>n E G</i>	State 0 when the information is true

The configuration [1] *P o 5* cannot be modified for the [Operating State "Fault"] *F L E*, [Brake Sequence] *b L C*, and [Mains Contactor] *L L C* assignments.

**[DQ11 hold delay]** *d I IH*★

DO11 holding delay time.

The holding time cannot be set for the **[Operating State "Fault"]** *F L E*, **[Brake Sequence]** *b L C*, and **[Mains Contactor]** *L L C* assignments, and remains at 0.

The change in state only takes effect once the configured time has elapsed when the information becomes false.

Setting	Description
0...9,999 ms	Setting range <b>Factory setting:</b> 0 ms

## [DQ12 Configuration] d o 12 - Menu

### Access

[Complete settings] → [Input/Output] → [DI/DQ] → [DQ12 Configuration]

### About This Menu

Identical to [DQ11 Configuration] d o 11 - Menu (see page 645).

Following parameters can be accessed if VW3A3203 I/O extension module has been inserted.

### [DQ12 Assignment] d o 12 ★

Digital output 12 assignment.

### [DQ12 actv delay] d 12 d ★

DO12 activation delay time.

### [DQ12 status] d 12 S ★

DO12 status (output active level).

### [DQ12 hold delay] d 12 H ★

DO12 holding delay time.

## Section 7.52

### [Input/Output] - [Analog I/O]

#### What Is in This Section?

This section contains the following topics:

Topic	Page
[AI1 configuration] <i>F</i> , 1 - Menu	649
[AI2 configuration] <i>F</i> , 2 - Menu	652
[AI3 configuration] <i>F</i> , 3 - Menu	654
[AI4 configuration] <i>F</i> , 4 - Menu	655
[AI5 configuration] <i>F</i> , 5 - Menu	657
[AQ1 configuration] <i>F</i> <i>a</i> 1 - Menu	658
[AQ2 configuration] <i>F</i> <i>a</i> 2 - Menu	662
[Virtual AI1] <i>F</i> <i>v</i> 1 - Menu	664



## [AI1 configuration] *R* , *I* - Menu

### Access

[Complete settings] → [Input/Output] → [AI/AQ] → [AI1 configuration]

### About This Menu

The input can be delinearized by configuring an intermediate point on the input/output curve of this input:

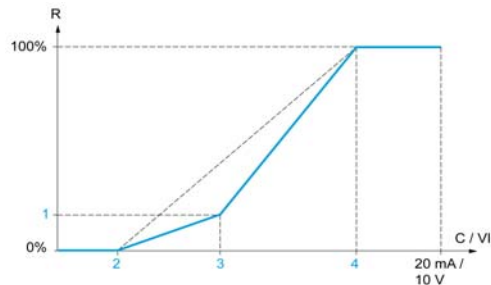

- R Reference
- C / VI Current or Voltage Input
- 1 [Y Interm. point]
- 2 [Min value] (0%)
- 3 [X Interm. point]
- 4 [Max value] (100%)

**NOTE:** For [X Interm. point], 0% corresponds to [Min value] and 100% to [Max value].

## [AI1 Assignment] *R* , *I* *R*

Analog input AI1 functions assignment.

Read-only parameter, cannot be configured. It displays all the functions associated with input AI1 in order to verify, for example, for compatibility problems.

If no functions have been assigned, [No] *n o* is displayed.

Setting	Code / Value	Description
[No]	<i>n o</i>	Not assigned
[AQ1 assignment]	<i>R a 1</i>	Analog output AQ1
[AQ2 assignment]	<i>R a 2</i>	Analog output AQ2
[Ref Freq Channel 1]	<i>F r 1</i>	Reference frequency channel 1 <b>Factory Setting</b>
[Ref Freq Channel 2]	<i>F r 2</i>	Reference frequency channel 2
[Ref Frequency 2 Summing]	<i>S R 2</i>	Reference frequency 2 summing
[PID Feedback]	<i>P , F</i>	PI controller feedback
[Subtract Ref Freq 2]	<i>d R 2</i>	Subtract reference frequency 2
[Manual PID Ref.]	<i>P , Π</i>	Manual speed reference of the PID controller (auto-man)
[PID Ref Frequency]	<i>F P , i</i>	PID reference frequency
[Ref Frequency 3 Summing]	<i>S R 3</i>	Reference frequency 3 summing
[Ref Frequency 1B]	<i>F r 1 b</i>	Reference frequency 1B
[Subtract Ref Freq 2]	<i>d R 3</i>	Subtract reference frequency 3
[Forced local]	<i>F L o C</i>	Forced local reference source1
[Ref Frequency 2 multiplier]	<i>Π R 2</i>	Reference frequency 2 multiplier
[Ref Frequency 3 multiplier]	<i>Π R 3</i>	Reference frequency 3 multiplier
[Virtual AI1 Channel]	<i>R , C 1</i>	Virtual AI1 channel selector function
[InletPres Assign]	<i>P 5 1 R</i>	Select the source of inlet pressure sensor
[OutletPres Assign]	<i>P 5 2 R</i>	Select the source of outlet pressure sensor
[Inst Flow Assign]	<i>F 5 1 R</i>	Select the source of installation flow sensor
[Pump Flow Assign]	<i>F 5 2 R</i>	Select the source of pump flow sensor

**[AI1 Type] R , I E**

Configuration of analog input AI1.

Setting	Code / Value	Description
[Voltage]	I 0 u	0-10 Vdc <b>Factory setting</b>
[Current]	0 R	0-20 mA

**[AI1 min value] u , L I ★**

AI1 voltage scaling parameter of 0%.

This parameter can be accessed if [AI1 Type] R , I E is set to [Voltage] I 0 u.

Setting	Description
0.0...10.0 Vdc	Setting range <b>Factory setting:</b> 0.0 Vdc

**[AI1 max value] u , H I ★**

AI1 voltage scaling parameter of 100%.

This parameter can be accessed if [AI1 Type] R , I E is set to [Voltage] I 0 u.

Setting	Description
0.0...10.0 Vdc	Setting range <b>Factory setting:</b> 10.0 Vdc

**[AI1 min. value] C r L I ★**

AI1 current scaling parameter of 0%.

This parameter can be accessed if [AI1 Type] R , I E is set to [Current] 0 R.

Setting	Description
0.0...20.0 mA	Setting range <b>Factory setting:</b> 0.0 mA

**[AI1 max. value] C r H I ★**

AI1 current scaling parameter of 100%.

This parameter can be accessed if [AI1 Type] R , I E is set to [Current] 0 R.

Setting	Description
0.0...20.0 mA	Setting range <b>Factory setting:</b> 20.0 mA

**[AI1 filter] R , I F**

AI1 cutoff time of the low filter.

Setting	Description
0.00...10.00 s	Setting range <b>Factory setting:</b> 0.00 s

**[AI1 X Interm. point]  $R_{IE}$** 

Input delinearization point coordinate. Percentage of the physical input signal.

0% corresponds to **[AI1 min value]** ( $\mu_{IL}$ )

100% corresponds to **[AI1 max value]** ( $\mu_{IH}$ )

Setting	Description
0...100%	Setting range <b>Factory setting:</b> 0%

**[AI1 Y Interm. point]  $R_{IS}$** 

Input delinearization point coordinate (frequency reference).

Percentage of the internal frequency reference corresponding to the **[AI1 X Interm. point]** ( $R_{IE}$ ) percentage of physical input signal.

Setting	Description
0...100%	Setting range <b>Factory setting:</b> 0%

## [AI2 configuration] *R , 2 - Menu*

### Access

[Complete settings] → [Input/Output] → [AI/AQ] → [AI2 configuration]

### [AI2 Assignment] *R , 2 R*

AI2 functions assignment.

Identical to [AI1 Assignment] *R , 1 R* (see page 649).

### [AI2 Type] *R , 2 E*

Configuration of analog input AI2.

Setting	Code / Value	Description
[Voltage]	<i>1 0 U</i>	0-10 Vdc <b>Factory setting</b>
[Current]	<i>0 R</i>	0-20 mA
[PTC Management]	<i>P E C</i>	1 to 6 PTC (in serial)
[KTY]	<i>K E Y</i>	1 KTY84
[PT1000]	<i>1 P E 3</i>	1 PT1000 connected with 2 wires
[PT100]	<i>1 P E 2</i>	1 PT100 connected with 2 wires
[Water Prob]	<i>L E U E L</i>	Water level
[3PT1000]	<i>3 P E 3</i>	3 PT1000 connected with 2 wires
[3PT100]	<i>3 P E 2</i>	3 PT100 connected with 2 wires

### [AI2 min value] *U , L 2 ★*

AI2 voltage scaling parameter of 0%.

This parameter can be accessed if [AI2 Type] *R , 2 E* is set to [Voltage] *1 0 U*.

Identical to [AI1 min value] *U , L 1* (see page 650).

### [AI2 max value] *U , H 2 ★*

AI2 voltage scaling parameter of 100%.

This parameter can be accessed if [AI2 Type] *R , 2 E* is set to [Voltage] *1 0 U*.

Identical to [AI1 max value] *U , H 1* (see page 650).

### [AI2 min. value] *C r L 2 ★*

AI2 current scaling parameter of 0%.

This parameter can be accessed if [AI2 Type] *R , 2 E* is set to [Current] *0 R*.

Identical to [AI1 min. value] *C r L 1* (see page 650).

### [AI2 max. value] *C r H 2 ★*

AI2 current scaling parameter of 100%.

This parameter can be accessed if [AI2 Type] *R , 2 E* is set to [Current] *0 R*.

Identical to [AI1 max. value] *C r H 1* (see page 650).

### [AI2 filter] *R , 2 F*

AI2 filter.

Identical to [AI1 filter] *R , 1 F* (see page 650).

### [AI2 X Interm. point] *R , 2 E*

AI2 delinearization input level.

Identical to [AI1 X Interm. point] *R , 1 E* (see page 651).

**[AI2 Y Interm. point] R , 2 5**

AI2 delinearization output level.

Identical to **[AI1 Y Interm. point] R , 1 5** (*see page 651*).

## [AI3 configuration] *R , 3 - Menu*

### Access

[Complete settings] → [Input/Output] → [AI/AQ] → [AI3 configuration]

### [AI3 Assignment] *R , 3 R*

AI3 functions assignment.

Identical to [AI1 Assignment] *R , 1 R* (see page 649).

### [AI3 Type] *R , 3 E*

Configuration of analog input AI3.

Identical to [AI2 Type] *R , 2 E* (see page 652) with factory setting: [Current] *0 R*.

### [AI3 min value] *u , L 3 ★*

AI3 voltage scaling parameter of 0%.

Identical to [AI1 min value] *u , L 1* (see page 650).

This parameter can be accessed if [AI3 Type] *R , 3 E* is set to [Voltage] *1 0 u*.

### [AI3 max value] *u , H 3 ★*

AI3 voltage scaling parameter of 100%.

Identical to [AI1 max value] *u , H 1* (see page 650).

This parameter can be accessed if [AI3 Type] *R , 3 E* is set to [Voltage] *1 0 u*.

### [AI3 min. value] *C r L 3 ★*

AI3 current scaling parameter of 0%.

Identical to [AI1 min. value] *C r L 1* (see page 650).

This parameter can be accessed if [AI3 Type] *R , 3 E* is set to [Current] *0 R*.

### [AI3 max. value] *C r H 3 ★*

AI3 current scaling parameter of 100%.

Identical to [AI1 max. value] *C r H 1* (see page 650).

This parameter can be accessed if [AI3 Type] *R , 3 E* is set to [Current] *0 R*.

### [AI3 filter] *R , 3 F*

AI3 cutoff time of the low filter.

Identical to [AI1 filter] *R , 1 F* (see page 650).

### [AI3 X Interm. point] *R , 3 E*

AI3 delinearization input level.

Identical to [AI1 X Interm. point] *R , 1 E* (see page 651).

### [AI3 Y Interm. point] *R , 3 S*

AI3 delinearization output level.

Identical to [AI1 Y Interm. point] *R , 1 S* (see page 651).

**[AI4 configuration] R , 4 - Menu****Access**

[Complete settings] → [Input/Output] → [AI/AQ] → [AI4 configuration]

**[AI4 Assignment] R , 4 R ★**

AI4 functions assignment.

This parameter can be accessed if VW3A3203 relay output option module has been inserted.

Identical to [AI1 Assignment] R , 1 R (see page 649).

**[AI4 Type] R , 4 E ★**

Configuration of analog input AI4.

This parameter can be accessed if VW3A3203 relay output option module has been inserted.

Setting	Code / Value	Description
[Voltage]	1 0 0	0-10 Vdc
[Current]	0 R	0-20 mA
[Voltage +/-]	n 1 0 0	-10/+10 Vdc <b>Factory setting</b>
[PTC Management]	P E C	1 to 6 PTC (in serial)
[KTY]	K E Y	1 KTY84
[PT1000]	1 P E 3	1 PT1000 connected with 2 wires
[PT100]	1 P E 2	1 PT100 connected with 2 wires
[3 PT1000]	3 P E 3	3 PT1000 connected with 2 wires
[3 PT100]	3 P E 2	3 PT100 connected with 2 wires
[PT1000 in 3 wires]	1 P E 3 3	1 PT1000 connected with 3 wires (AI4 & AI5 only)
[PT100 in 3 wires]	1 P E 2 3	1 PT100 connected with 3 wires (AI4 & AI5 only)
[3 PT1000 in 3 wires]	3 P E 3 3	3 PT1000 connected with 3 wires (AI4 & AI5 only)
[3 PT100 in 3 wires]	3 P E 2 3	3 PT100 connected with 3 wires (AI4 & AI5 only)

**[AI4 min value] 0 , L 4 ★**

AI4 voltage scaling parameter of 0%.

Identical to [AI1 min value] 0 , L 1 (see page 650).

**[AI4 max value] 0 , H 4 ★**

AI4 voltage scaling parameter of 100%.

Identical to [AI1 max value] 0 , H 1 (see page 650).

**[AI4 min. value] C r L 4 ★**

AI4 current scaling parameter of 0%.

Identical to [AI1 min. value] C r L 1 (see page 650).

**[AI4 max. value] C r H 4 ★**

AI4 current scaling parameter of 100%.

Identical to [AI1 max. value] C r H 1 (see page 650).

**[AI4 filter] R , 4 F ★**

AI4 cutoff time of the low filter.

This parameter can be accessed if VW3A3203 relay output option module has been inserted.

Identical to [AI1 filter] R , 1 F (see page 650).

**[AI4 X Interm. point] R , 4 E ★**

AI4 delinearization input level.

This parameter can be accessed if VW3A3203 relay output option module has been inserted.

Identical to **[AI1 X Interm. point] R , 1 E** (*see page 651*).

**[AI4 Y Interm. point] R , 4 S ★**

AI4 delinearization output level.

This parameter can be accessed if VW3A3203 relay output option module has been inserted.

Identical to **[AI1 Y Interm. point] R , 1 S** (*see page 651*).



**[AI5 configuration] R , 5 - Menu****Access**

[Complete settings] → [Input/Output] → [AI/AQ] → [AI5 configuration]

**[AI5 Assignment] R , 5 R ★**

AI5 functions assignment.

This parameter can be accessed if VW3A3203 relay output option module has been inserted.

Identical to [AI1 Assignment] R , 1 R (see page 649).

**[AI5 Type] R , 5 E ★**

Configuration of analog input AI5 .

This parameter can be accessed if VW3A3203 relay output option module has been inserted.

Identical to [AI4 Type] R , 4 E . (see page 655)

**[AI5 min value] U , L 5 ★**

AI5 voltage scaling parameter of 0%.

Identical to [AI1 min value] U , L 1 (see page 650).

**[AI5 max value] U , H 5 ★**

AI5 voltage scaling parameter of 100%.

Identical to [AI1 max value] U , H 1 (see page 650).

**[AI5 min. value] C r L 5 ★**

AI5 current scaling parameter of 0%.

Identical to [AI1 min. value] C r L 1 (see page 650).

**[AI5 max. value] C r H 5 ★**

AI5 current scaling parameter of 100%.

Identical to [AI1 max. value] C r H 1 (see page 650).

**[AI5 filter] R , 5 F ★**

AI5 cutoff time of the low filter.

This parameter can be accessed if VW3A3203 relay output option module has been inserted.

Identical to [AI1 filter] R , 1 F (see page 650).

**[AI5 X Interm. point] R , 5 E ★**

AI5 delinearization input level.

This parameter can be accessed if VW3A3203 relay output option module has been inserted.

Identical to [AI1 X Interm. point] R , 1 E (see page 651).

**[AI5 Y Interm. point] R , 5 S ★**

AI5 delinearization output level.

This parameter can be accessed if VW3A3203 relay output option module has been inserted.

Identical to [AI1 Y Interm. point] R , 1 S (see page 651).

## [AQ1 configuration] *R 0 1* - Menu

### Access

[Complete settings] → [Input/Output] → [AI/AQ] → [AQ1 configuration]

### Minimum and Maximum Output Values

The minimum output value, in volts, corresponds to the lower limit of the assigned parameter and the maximum value corresponds to its upper limit. The minimum value may be greater than the maximum value.

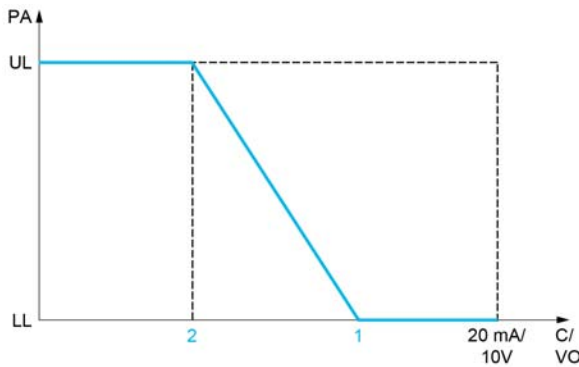
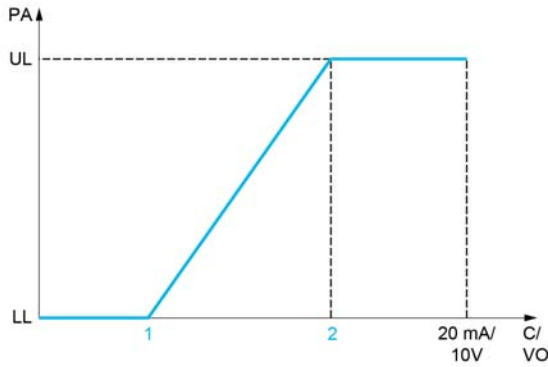

- PA Parameter assigned
- C / VO Current or voltage output
- UL Upper limit
- LL Lower limit
- 1 [Min Output] *R 0 L X* or *u 0 L X*
- 2 [Max Output] *R 0 H X* or *u 0 H X*

### Scaling of the Assigned Parameter

The scale of the assigned parameter can be adapted in accordance with the requirements by modifying the values of the lower and upper limits with 2 parameters for each analog output.

These parameters are given in %. 100% corresponds to the total variation range of the configured parameter, so: 100% = upper limit - lower limit.

For example, [Sign. torque] *5 L 9* which varies between -3 and +3 times the rated torque, 100% corresponds to 6 times the rated torque.

- The [Scaling AQx min] *R 5 L X* parameter modifies the lower limit: new value = lower limit + (range x *R 5 L X*). The value 0% (factory setting) does not modify the lower limit.
- The [Scaling AQx max] *R 5 H X* parameter modifies the upper limit: new value = lower limit + (range x *R 5 L X*). The value 100% (factory setting) does not modify the upper limit.
- [Scaling AQx min] *R 5 L X* must always be lower than [Scaling AQx max] *R 5 H X*.

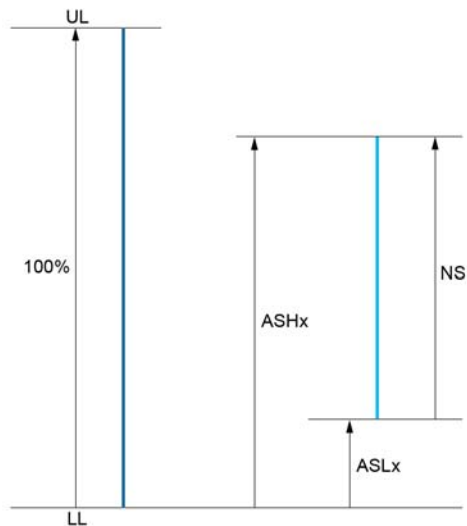

- UL** Upper limit of the assigned parameter  
**LL** Lower limit of the assigned parameter  
**NS** New scale  
**1** *ASHX*  
**2** *ASLX*

### Application Example

The value of the motor current at the AO1 output is to be transferred with 0...20 mA, range 2 in motor, In motor being the equivalent of a 0.8 In drive.

- The **[Motor Current]** *oCr* parameter varies from 0 to 2 times the rated drive current, or a range of 2.5 times the rated drive current.
- **[Scaling AQ1 min]** *ASL* must not modify the lower limit, which therefore remains at its factory setting of 0%.
- **[Scaling AQ1 max]** *ASH* must modify the upper limit by 0.5x the rated motor torque, or 100 - 100/5 = 80% (new value = lower limit + (range x **[Scaling AQ1 max]** *ASH*)).

### [AQ1 Assignment] *ASL*

AO1 assignment.

Setting	Code / Value	Description
<b>[Not Configured]</b>	<i>na</i>	Not assigned <b>Factory Setting</b>
<b>[Motor Current]</b>	<i>oCr</i>	Current in the motor, from 0 to 2 In (In = rated drive current indicated in the Installation manual and on the drive nameplate)
<b>[Motor Frequency]</b>	<i>oFr</i>	Output frequency, from 0 to <b>[Max Frequency]</b> <i>EFr</i>
<b>[Ramp out.]</b>	<i>orP</i>	From 0 to <b>[Max Frequency]</b> <i>EFr</i>
<b>[Motor torq.]</b>	<i>Erq</i>	Motor torque, from 0 to 3 times the rated motor torque
<b>[Sign. torque]</b>	<i>Stq</i>	Signed motor torque, between -3 and +3 times the rated motor torque. The + sign corresponds to the motor mode and the - sign to the generator mode (braking).
<b>[sign ramp]</b>	<i>orS</i>	Signed ramp output, between - <b>[Max Frequency]</b> <i>EFr</i> and + <b>[Max Frequency]</b> <i>EFr</i>
<b>[PID ref.]</b>	<i>oPS</i>	PID controller reference between <b>[Min PID reference]</b> <i>PiP1</i> and <b>[Max PID reference]</b> <i>PiP2</i>
<b>[PID feedbk]</b>	<i>oPF</i>	PID controller feedback between <b>[Min PID feedback]</b> <i>PiF1</i> and <b>[Max PID feedback]</b> <i>PiF2</i>
<b>[PID error]</b>	<i>oPE</i>	PID controller detected error between -5% and +5% of <b>[Max PID feedback]</b> <i>PiF2</i> - <b>[Min PID feedback]</b> <i>PiF1</i>
<b>[PID output]</b>	<i>oPi</i>	PID controller output between <b>[Low speed]</b> <i>LSP</i> and <b>[High speed]</b> <i>HSP</i>
<b>[Drive power]</b>	<i>oPr</i>	Motor power, between 0 and 2.5 times <b>[Nominal Motor Power]</b> <i>nPr</i>

Setting	Code / Value	Description
[Mot thermal]	<i>t H r</i>	Motor thermal state, from 0 to 200% of the rated thermal state
[Drv thermal]	<i>t H d</i>	Drive thermal state, from 0 to 200% of the rated thermal state
[Sig. o/p frq.]	<i>o F 5</i>	Signed output frequency, between <b>-[Max Frequency] t F r</b> and <b>+[Max Frequency] t F r</b>
[Motor volt.]	<i>u o P</i>	Voltage applied to the motor, between 0 and <b>[Nom Motor Voltage] u n 5</b> warning
[Inlet Pressure Value]	<i>P 5 1 u</i>	Inlet pressure value
[Outlet Pressure Value]	<i>P 5 2 u</i>	Outlet pressure value
[Installation Flow]	<i>F 5 1 u</i>	Installation flow value

**[AQ1 Type] R o I t**

AO1 type.

Setting	Code / Value	Description
[Voltage]	<i>1 0 u</i>	0-10 Vdc <b>Factory setting</b>
[Current]	<i>0 R</i>	0-20 mA

**[AQ1 min output] R o L I ★**

AO1 current scaling parameter of 0%.

This parameter can be accessed if **[AQ1 Type] R o I t** is set to **[Current] 0 R**.

Setting	Description
0.0...20.0 mA	Setting range <b>Factory setting:</b> 0.0 mA

**[AQ1 max output] R o H I ★**

AO1 current scaling parameter of 100%.

This parameter can be accessed if **[AQ1 Type] R o I t** is set to **[Current] 0 R**.

Setting	Description
0.0...20.0 mA	Setting range <b>Factory setting:</b> 20.0 mA

**[AQ1 min Output] u o L I ★**

AO1 voltage scaling parameter of 0%.

This parameter can be accessed if **[AQ1 Type] R o I t** is set to **[Voltage] 1 0 u**.

Setting	Description
0.0...10.0 Vdc	Setting range <b>Factory setting:</b> 0.0 Vdc

**[AQ1 max Output] u o H I ★**

AO1 voltage scaling parameter of 100%.

This parameter can be accessed if **[AQ1 Type] R o I t** is set to **[Voltage] 1 0 u**.

Setting	Description
0.0...10.0 Vdc	Setting range <b>Factory setting:</b> 10.0 Vdc

**[Scaling AQ1 min] R 5 L I**

AO1 scaling parameter of 0%.

Scaling of the lower limit of the assigned parameter, as a % of the maximum possible variation.

Setting	Description
0.0...100.0%	Setting range <b>Factory setting:</b> 0.0%

**[Scaling AQ1 max] R 5 H I**

AO1 scaling parameter of 100%.

Scaling of the upper limit of the assigned parameter, as a % of the maximum possible variation.

Setting	Description
0.0...100.0%	Setting range <b>Factory setting:</b> 100.0%

**[AQ1 Filter] R 0 I F**

AO1 cutoff time of the low-filter.

Setting	Description
0.00...10.00 s	Setting range <b>Factory setting:</b> 0.00 s

**[AQ2 configuration] *F 0 2* - Menu**

**Access**

[Complete settings] → [Input/Output] → [AI/AQ] → [AQ2 configuration]

**[AQ2 assignment] *F 0 2***

AO2 assignment.

Identical to [AQ1 assignment] *F 0 1* (see page 659).

**[AQ2 Type] *F 0 2 E***

AO2 type.

Setting	Code / Value	Description
[Voltage]	<i>I 0 U</i>	0-10 Vdc <b>Factory setting</b>
[Current]	<i>0 R</i>	0-20 mA
[PTC Management]	<i>P E C</i>	1 to 6 PTC (in serial)
[KTY]	<i>K E Y</i>	1 KTY84
[PT1000]	<i>I P E 3</i>	1 PT1000 connected with 2 wires
[PT100]	<i>I P E 2</i>	1 PT100 connected with 2 wires
[Water Prob]	<i>L E U E L</i>	Water level
[3PT1000]	<i>3 P E 3</i>	3 PT1000 connected with 2 wires
[3PT100]	<i>3 P E 2</i>	3 PT100 connected with 2 wires

**[AQ2 min output] *F 0 L 2* ★**

AO2 current scaling parameter of 0%.

This parameter can be accessed if [AQ2 Type] *F 0 2 E* is set to [Current] *0 R*.

Identical to [AQ1 min output] *F 0 L 1* (see page 660).

**[AQ2 max output] *F 0 H 2* ★**

AO2 current scaling parameter of 100%.

This parameter can be accessed if [AQ2 Type] *F 0 2 E* is set to [Current] *0 R*.

Identical to [AQ1 max output] *F 0 H 1* (see page 660).

**[AQ2 min Output] *U 0 L 2* ★**

AO2 voltage scaling parameter of 0%.

This parameter can be accessed if [AQ2 Type] *F 0 2 E* is set to [Voltage] *I 0 U*.

Identical to [AQ1 min Output] *U 0 L 1* (see page 660).

**[AQ2 max Output] *U 0 H 2* ★**

AO2 voltage scaling parameter of 100%.

This parameter can be accessed if [AQ2 Type] *F 0 2 E* is set to [Voltage] *I 0 U*.

Identical to [AQ1 max Output] *U 0 H 1* (see page 660).

**[Scaling AQ2 min] *F 5 L 2***

AQ2 scaling parameter of 0%.

Identical to [Scaling AQ1 min] *F 5 L 1* (see page 661).

**[Scaling AQ2 max] R 5 H 2**

AO2 scaling parameter of 100%.

Identical to **[Scaling AQ1 max] R 5 H 1** (*see page 661*).

**[AQ2 Filter] R 0 2 F**

AO2 cutoff time of the low-filter.

Identical to **[AQ1 Filter] R 0 1 F** (*see page 661*).

**[Virtual AI1] *R L I* - Menu****Access**

[Complete settings] → [Input/Output] → [AI/AQ] → [Virtual AI1]

**[AIV1 Assignment] *R L I A***

Virtual AI1 function assignment.

Setting	Code / Value	Description
[No]	<i>n o</i>	Not assigned
[AQ1 assignment]	<i>A o 1</i>	Analog output AQ1
[AQ2 assignment]	<i>A o 2</i>	Analog output AQ2
[Ref Freq Channel 1]	<i>F r 1</i>	Reference frequency channel 1 <b>Factory Setting</b>
[Ref Freq Channel 2]	<i>F r 2</i>	Reference frequency channel 2
[Ref Frequency 2 Summing]	<i>S R 2</i>	Reference frequency 2 summing
[PID Feedback]	<i>P , F</i>	PI controller feedback
[Subtract Ref Freq 2]	<i>d R 2</i>	Subtract reference frequency 2
[Manual PID Ref.]	<i>P , Π</i>	Manual speed reference of the PID controller (auto-man)
[PID Ref Frequency]	<i>F P ,</i>	PID reference frequency
[Ref Frequency 3 Summing]	<i>S R 3</i>	Reference frequency 3 summing
[Ref Frequency 1B]	<i>F r 1 b</i>	Reference frequency 1B
[Subtract Ref Freq 2]	<i>d R 3</i>	Subtract reference frequency 3
[Forced local]	<i>F L o C</i>	Forced local reference source1
[Ref Frequency 2 multiplier]	<i>Π R 2</i>	Reference frequency 2 multiplier
[Ref Frequency 3 multiplier]	<i>Π R 3</i>	Reference frequency 3 multiplier
[Virtual AI1 Channel]	<i>R , C 1</i>	Virtual AI1 channel selector function
[InletPres Assign]	<i>P S 1 A</i>	Select the source of inlet pressure sensor
[OutletPres Assign]	<i>P S 2 A</i>	Select the source of outlet pressure sensor
[Inst Flow Assign]	<i>F S 1 A</i>	Select the source of installation flow sensor
[Pump Flow Assign]	<i>F S 2 A</i>	Select the source of pump flow sensor

**[AIV1 Channel Assignment] *R , C 1***

Channel assignment for virtual analog input AIV1.

Setting	Code / Value	Description
[Not Configured]	<i>n o</i>	Not assigned <b>Factory setting</b>
[Ref. Freq-Modbus]	<i>Π d b</i>	Reference frequency via Modbus
[Ref. Freq-CANopen]	<i>C A n</i>	Reference frequency via CANopen if a CANopen module has been inserted
[Ref. Freq-Com. Module]	<i>n E t</i>	Reference frequency via fieldbus module if a fieldbus module has been inserted
[Embedded Ethernet]	<i>E t H</i>	Embedded Ethernet



---

## Section 7.53

### [Input/Output] - [Relay]

---

#### What Is in This Section?

This section contains the following topics:

Topic	Page
[R1 configuration] r 1 - Menu	666
[R2 configuration] r 2 - Menu	668
[R3 configuration] r 3 - Menu	669
[R4 configuration] r 4 - Menu	670
[R5 configuration] r 5 - Menu	671
[R6 configuration] r 6 - Menu	672

**[R1 configuration] *r / -* Menu****Access****[Complete settings] → [Input/Output] → [Relay] → [R1 configuration]****[R1 Assignment] *r /***

R1 assignment.

Setting	Code / Value	Description
[No]	<i>n o</i>	Not assigned <b>Factory setting</b>
[Operating State "Fault"]	<i>F L t</i>	Operating state fault
[Drive Running]	<i>r u n</i>	Drive running
[Mot Freq High Thd]	<i>F t R</i>	Motor frequency threshold ( <b>[Motor Freq Thd] <i>F t d</i></b> ) reached
[High Speed Reached]	<i>F L R</i>	High speed reached
[Current Thd Reached]	<i>C t R</i>	Motor current threshold ( <b>[High Current Thd] <i>C t d</i></b> ) reached
[Ref Freq Reached]	<i>S r R</i>	Frequency reference reached
[Motor Therm Thd Reached]	<i>t S R</i>	Motor thermal threshold ( <b>[Motor Therm Thd] <i>t t d</i></b> ) reached
[PID Error Warning]	<i>P E E</i>	PID error warning
[PID Feedback Warning]	<i>P F R</i>	PID feedback warning
[AI2 4-20 Loss Warning]	<i>R P 2</i>	AI2 4-20 mA loss warning
[2nd Freq Thd Reached]	<i>F 2 R</i>	Second frequency threshold ( <b>[Freq. threshold 2] <i>F 2 d</i></b> ) reached
[Drv Therm Thd Reached]	<i>t R d</i>	Drive thermal threshold reached
[Ref Freq High Thd Reached]	<i>r t R H</i>	Frequency reference high threshold reached
[Ref Freq Low Thd Reached]	<i>r t R L</i>	Frequency reference low threshold reached
[Mot Freq Low Thd]	<i>F t R L</i>	Frequency low threshold ( <b>[Low Freq.Threshold] <i>F t d L</i></b> ) reached
[Motor Freq Low 2]	<i>F 2 R L</i>	Second frequency low threshold ( <b>[2 Freq. Threshold] <i>F 2 d L</i></b> ) reached
[Low Current Reached]	<i>C t R L</i>	Current low threshold ( <b>[Low I Threshold] <i>C t d L</i></b> ) reached
[Process Undld Warning]	<i>u L R</i>	Underload warning
[Process Overload Warning]	<i>o L R</i>	Overload warning
[Forward]	<i>Π F r d</i>	Run forward
[Reverse]	<i>Π r r S</i>	Run reverse
[Neg Torque]	<i>R t S</i>	Actual torque sign
[Config. No.1]	<i>C n F 0</i>	Configuration 0 active
[set 1 active]	<i>C F P 1</i>	Parameter set 1 active
[set 2 active]	<i>C F P 2</i>	Parameter set 2 active
[set 3 active]	<i>C F P 3</i>	Parameter set 3 active
[DC Bus Charged]	<i>d b L</i>	DC bus charged
[Power removal state]	<i>P r Π</i>	Power removal state
[I present]	<i>Π C P</i>	Motor current present
[Warning Grp 1]	<i>R G 1</i>	Warning group 1
[Warning Grp 2]	<i>R G 2</i>	Warning group 2
[Warning Grp 3]	<i>R G 3</i>	Warning group 3
[Warning Grp 4]	<i>R G 4</i>	Warning group 4
[Warning Grp 5]	<i>R G 5</i>	Warning group 5
[External Error Warning]	<i>E F R</i>	External error warning
[Undervoltage Warning]	<i>u S R</i>	Undervoltage warning
[Preventive UnderV Active]	<i>u P R</i>	Undervoltage prevention warning
[Drive Thermal Warning]	<i>t H R</i>	Drive thermal state warning

Setting	Code / Value	Description
[IGBT Thermal Warning]	<i>£ J R</i>	Thermal junction warning
[AI3 4-20 Loss Warning]	<i>R P £</i>	AI3 4-20 mA loss warning
[Ready]	<i>r d Y</i>	Ready to start
[AI1 4-20 Loss Warning]	<i>R P I</i>	AI1 4-20 mA loss warning

**[R1 Delay time] *r I d***

R1 activation delay time.

The change in state takes effect once the configured time has elapsed when the information becomes true.

The delay cannot be set for the [Operating State "Fault"] *F L £* assignment; and remains at 0.

Setting	Description
0...60,000 ms	Setting range <b>Factory setting:</b> 0 ms

**[R1 Active at] *r I S***

R1 status (output active level).

Setting	Code / Value	Description
1	<i>P o S</i>	State 1 when the information is true <b>Factory setting</b>
0	<i>n E £</i>	State 0 when the information is true

Configuration [1] *P o S* cannot be modified for the [Operating State "Fault"] *F L £* assignment.

**[R1 Holding time] *r I H***

R1 holding delay time.

The change in state takes effect once the configured time has elapsed when the information becomes false.

The holding time cannot be set for the [Operating State "Fault"] *F L £* assignment, and remains at 0.

Setting	Description
0...9,999 ms	Setting range <b>Factory setting:</b> 0 ms

**[R2 configuration] r 2 - Menu****Access**

[Complete settings] → [Input/Output] → [Relay] → [R2 configuration]

**About This Menu**

Identical to [R1 configuration] r 1 - Menu (*see page 666*).

**[R2 Assignment] r 2**

R2 assignment.

Identical to [R1 Assignment] r 1 (*see page 666*) in addition to:

Setting	Code / Value	Description
[Mains Contactor]	L L C	Mains contactor control
[Jockey]	J o K y	Jockey
[Priming]	P r i m	Priming
[Pump 1 Cmd]	Π P o 1	Pump 1 command
[Pump 2 Cmd]	Π P o 2	Pump 2 command
[Pump 3 Cmd]	Π P o 3	Pump 3 command
[Pump 4 Cmd]	Π P o 4	Pump 4 command
[Pump 5 Cmd]	Π P o 5	Pump 5 command
[Pump 6 Cmd]	Π P o 6	Pump 6 command

**[R2 Delay time] r 2 d**

R2 activation delay time.

**[R2 Active at] r 2 5**

R2 status (output active level).

**[R2 Holding time] r 2 H**

R2 holding delay time.

## [R3 configuration] *r 3* - Menu

### Access

[Complete settings] → [Input/Output] → [Relay] → [R3 configuration]

### About This Menu

Identical to [R1 configuration] *r 1* - Menu (*see page 666*).

### [R3 Assignment] *r 3*

R3 assignment.

Identical to [R2 Assignment] *r 2* (*see page 668*).

### [R3 Delay time] *r 3 d*

R3 activation delay time.

### [R3 Active at] *r 3 5*

R3 status (output active level).

### [R3 Holding time] *r 3 H*

R3 holding delay time.

## [R4 configuration] r 4 - Menu

### Access

[Complete settings] → [Input/Output] → [Relay] → [R4 configuration]

### About This Menu

Identical to [R1 configuration] r 1 - Menu (*see page 666*).

Following parameters can be accessed if VW3A3204 relay output option module has been inserted.

### [R4 Assignment] r 4 ★

R4 assignment.

Identical to [R2 Assignment] r 2 (*see page 668*).

### [R4 Delay time] r 4 d ★

R4 activation delay time.

### [R4 Active at] r 4 5 ★

R4 status (output active level).

### [R4 Holding time] r 4 H ★

R4 holding delay time.

## [R5 configuration] r 5 - Menu

### Access

[Complete settings] → [Input/Output] → [Relay] → [R5 configuration]

### About This Menu

Identical to [R1 configuration] r 1 - Menu (see page 666).

Following parameters can be accessed if VW3A3204 relay output option module has been inserted.

### [R5 Assignment] r 5 ★

R5 assignment.

Identical to [R2 Assignment] r 2 (see page 668).

### [R5 Delay time] r 5 d ★

R5 activation delay time.

### [R5 Active at] r 5 s ★

R5 status (output active level).

### [R5 Holding time] r 5 H ★

R5 holding delay time.

## [R6 configuration] *r 6* - Menu

### Access

[Complete settings] → [Input/Output] → [Relay] → [R6 configuration]

### About This Menu

Identical to [R1 configuration] *r 1* - Menu (*see page 666*).

Following parameters can be accessed if VW3A3204 relay output option module has been inserted.

### [R6 Assignment] *r 6* ★

R6 assignment.

Identical to [R2 Assignment] *r 2* (*see page 668*).

### [R6 Delay time] *r 6 d* ★

R6 activation delay time.

### [R6 Active at] *r 6 5* ★

R6 status (output active level).

### [R6 Holding time] *r 6 H* ★

R6 holding delay time.



## Section 7.54

### [Error/Warning handling]

#### What Is in This Section?

This section contains the following topics:

Topic	Page
[Auto fault reset] <i>A E r</i> - Menu	674
[Fault reset] <i>r S E</i> - Menu	675
[Catch on the fly] <i>F L r</i> - Menu	677
[Error detection disable] <i>i n H</i> - Menu	678
[External error] <i>E E F</i> - Menu	679
[Output phase loss] <i>o P L</i> - Menu	681
[Input phase loss] <i>i P L</i> - Menu	682
[4-20mA loss] <i>L F L</i> - Menu	683
[Fallback speed] <i>L F F</i> - Menu	684
[Fieldbus monitoring] <i>C L L</i> - Menu	685
[Embedded Modbus TCP] <i>E n E C</i> - Menu	686
[Communication module] <i>C o m o</i> - Menu	687
[Undervoltage handling] <i>u S b</i> - Menu	689
[Ground Fault] <i>G r F L</i> - Menu	691
[Warn grp 1 definition] <i>A 1 C</i> - Menu	692
[Warn grp 2 definition] <i>A 2 C</i> - Menu	694
[Warn grp 3 definition] <i>A 3 C</i> - Menu	695
[Warn grp 4 definition] <i>A 4 C</i> - Menu	696
[Warn grp 5 definition] <i>A 5 C</i> - Menu	697

**[Auto fault reset] *A E r* - Menu**

**Access**

[Complete settings] → [Error/Warning handling] → [Auto fault reset]

**[Auto Fault Reset] *A E r*** 

Automatic restart.

This function can be used to automatically perform individual or multiple Fault Resets. If the cause of the error that has triggered the transition to the operating state Fault disappears within while this function is active, the drive resumes normal operation. While the Fault Reset attempts are performed automatically, the output signal **[Operating state Fault]** is not available. If the attempts to perform the Fault Reset are not successful, the drive remains in the operating state Fault and the output signal **[Operating state Fault]** becomes active.

<b> WARNING</b>
<p><b>UNANTICIPATED EQUIPMENT OPERATION</b></p> <ul style="list-style-type: none"> <li>• Verify that activating this function does not result in unsafe conditions.</li> <li>• Verify that the fact that the output signal "Operating state Fault" is not available while this function is active does not result in unsafe conditions.</li> </ul> <p><b>Failure to follow these instructions can result in death, serious injury, or equipment damage.</b></p>

The drive fault relay remains activated if this function is active. The speed reference and the operating direction must be maintained.

It is recommended to use 2-wire control (**[2/3-wire control] *E C C*** is set to **[2 wire] *2 C*** and **[2-wire type] *E C E*** is set to **[Level] *L E L***, refer to **[2/3-wire control] *E C C***.

If the restart has not taken place once the configurable time **[Fault Reset Time] *E R r*** has elapsed, the procedure is aborted and the drive remains locked until it is turned off and then on again.

The detected error codes, which permit this function, are listed in the Diagnostics part of the manual.

Setting	Code / Value	Description
<b>[No]</b>	<i>n o</i>	Function inactive <b>Factory setting</b>
<b>[Yes]</b>	<i>Y E 5</i>	Automatic restart, after locking in error state, if the detected error has disappeared and the other operating conditions permit the restart. The restart is performed by a series of automatic attempts separated by increasingly longer waiting periods: 1 s, 5 s, 10 s, then 1 minute for the following attempts.

**[Fault Reset Time] *E R r* ★**

Maximum time for automatic restart function.

This parameter appears if **[Auto Fault Reset] *A E r*** is set to **[Yes] *Y E 5***. It can be used to limit the number of consecutive restarts on a recurrent detected error.

Setting	Code / Value	Description
<b>[5 minutes]</b>	<i>5</i>	5 minutes <b>Factory setting</b>
<b>[10 minutes]</b>	<i>1 0</i>	10 minutes
<b>[30 minutes]</b>	<i>3 0</i>	30 minutes
<b>[1 hour]</b>	<i>1 h</i>	1 hour
<b>[2 hours]</b>	<i>2 h</i>	2 hours
<b>[3 hours]</b>	<i>3 h</i>	3 hours
<b>[Unlimited]</b>	<i>C E</i>	Continuous

**[Fault reset] r 5 E - Menu****Access**

[Complete settings] → [Error/Warning handling] → [Fault reset]

**[Fault Reset Assign] r 5 F**

Error reset input assignment.

Detected errors are cleared manually when the assigned input or bit changes to 1 if the cause of the detected error has disappeared.

The **STOP/RESET** key on the Graphic Display Terminal performs the same function.

Setting	Code / Value	Description
[Not Assigned]	n o	Not assigned <b>Factory setting</b>
[DI1]...[DI6]	L , / ... L , 6	Digital input DI1...DI6
[DI11]...[DI16]	L , / / ... L , / 6	Digital input DI11...DI16 if VW3A3203 I/O extension module has been inserted

**[Product Restart] r P ★**

The Restart function performs a Fault Reset and then restarts the drive. During this Restart procedure, the drive goes through the same steps as if it had been switched off and on again. Depending on the wiring and the configuration of the drive, this may result in immediate and unanticipated operation.

**⚠ WARNING****UNANTICIPATED EQUIPMENT OPERATION**

The Restart function performs a Fault Reset and restarts the drive.

- Verify that activating this function does not result in unsafe conditions.

**Failure to follow these instructions can result in death, serious injury, or equipment damage.**

Product restart.

This parameter can be accessed if [Access Level] *L R C* is set to [Expert] *E P r* mode.

This parameter can be used to reset all detected errors without having to disconnect the drive from the supply mains.

Setting	Code / Value	Description
[No]	n o	Function inactive <b>Factory setting</b>
[Yes]	Y E 5	Reinitialization. Press and hold down the OK key for 2 s. The parameter changes back to [No] <i>n o</i> automatically as soon as the operation is complete. The drive can only be reinitialized when locked.

**[Prod Restart Assign] r P A ★ ⏳**

Product restart assignment.

The Restart function performs a Fault Reset and then restarts the drive. During this Restart procedure, the drive goes through the same steps as if it had been switched off and on again. Depending on the wiring and the configuration of the drive, this may result in immediate and unanticipated operation. The Restart function can be assigned to a digital input

**⚠ WARNING****UNANTICIPATED EQUIPMENT OPERATION**

The Restart function performs a Fault Reset and restarts the drive.

- Verify that activating this function does not result in unsafe conditions.

**Failure to follow these instructions can result in death, serious injury, or equipment damage.**

This parameter can be accessed if **[Access Level] L R C** is set to **[Expert] E P r** mode.

Setting	Code / Value	Description
<b>[Not Assigned]</b>	<i>n o</i>	Not assigned <b>Factory setting</b>
<b>[DI1]...[DI6]</b>	<i>L , I...L , E</i>	Digital input DI1...DI6
<b>[DI11]...[DI16]</b>	<i>L , I I...L , I E</i>	Digital input DI11...DI16 if VW3A3203 I/O extension module has been inserted

## [Catch on the fly] *F L r* - Menu

### Access

[Complete settings] → [Error/Warning handling] → [Catch on the fly]

### [Catch On Fly] *F L r*

Catch on the fly.

Used to enable a smooth restart if the run command is maintained after the following events:

- Loss of line supply or disconnection.
- Clearance of current detected error or automatic restart.
- Freewheel stop.

The speed given by the drive resumes from the estimated speed of the motor at the time of the restart, then follows the ramp to the reference speed.

This function requires 2-wire level control.

When the function is operational, it activates at each run command, resulting in a slight delay of the current (0.5 s max).

[Catch On Fly] *F L r* is forced to [No] *n o* if [Auto DC Injection] *A d C* is set to [Continuous] *C t*.

Setting	Code / Value	Description
[No]	<i>n o</i>	Function inactive <b>Factory setting</b>
[Yes]	<i>y e s</i>	Function active

### [Catch on Fly Sensitivity] *u C b* ★

Catch on fly sensitivity.

This parameter can only be accessed if [Access Level] *L A C* is set to [Expert] *E P r*.

Setting	Description
0.10...100.00 V	Setting range <b>Factory setting:</b> 0.20 V

**[Error detection disable] *INH* - Menu**

**Access**

[Complete settings] → [Error/Warning handling] → [Error detection disable]

**About This Menu**

**⚠ DANGER**

**MONITORING FUNCTIONS DISABLED, NO ERROR DETECTION**

- Only use this parameter after a thorough risk assessment in compliance with all regulations and standards that apply to the device and to the application.
- Implement alternative monitoring functions for disabled monitoring functions that do not trigger automatic error responses of the drive, but allow for adequate, equivalent responses by other means in compliance with all applicable regulations and standards as well as the risk assessment.
- Commission and test the system with the monitoring functions enabled.
- During commissioning, verify that the drive and the system operate as intended by performing tests and simulations in a controlled environment under controlled conditions.

**Failure to follow these instructions will result in death or serious injury.**

**[ErrorDetect Disabled] *INH*★**

Disable error detection.

This parameter can be accessed if [Access Level] *LAC* is set to [Expert] *EP*.

Setting	Code / Value	Description
[Not Assigned]	<i>no</i>	Not assigned <b>Factory setting</b>
[DI1]...[DI6]	<i>L 1 L 15</i>	Digital input DI1...DI6
[DI11]...[DI16]	<i>L 11 L 16</i>	Digital input DI11...DI16 if VW3A3203 I/O extension module has been inserted
[CD00]...[CD10]	<i>C d 00 C d 10</i>	Virtual digital input CMD.0...CMD.10 in [I/O profile] <i>no</i> configuration
[CD11]...[CD15]	<i>C d 11 C d 15</i>	Virtual digital input CMD.11...CMD.15 regardless of configuration
[C100]...[C110]	<i>C 100 C 110</i>	Virtual digital input CMD1.0...CMD1.10 with integrated Modbus Serial in [I/O profile] <i>no</i> configuration
[C111]...[C115]	<i>C 111 C 115</i>	Virtual digital input CMD1.11...CMD1.15 with integrated Modbus Serial regardless of configuration
[C200]...[C210]	<i>C 200 C 210</i>	Virtual digital input CMD2.0...CMD2.10 with CANopen® fieldbus module in [I/O profile] <i>no</i> configuration
[C211]...[C215]	<i>C 211 C 215</i>	Virtual digital input CMD2.11...CMD2.15 with CANopen® fieldbus module regardless of configuration
[C300]...[C310]	<i>C 300 C 310</i>	Virtual digital input CMD3.0...CMD3.10 with a fieldbus module in [I/O profile] <i>no</i> configuration
[C311]...[C315]	<i>C 311 C 315</i>	Virtual digital input CMD3.11...CMD3.15 with a fieldbus module regardless of configuration
[C500]...[C510]	<i>C 500 C 510</i>	Virtual digital input CMD5.0...CMD5.10 with integrated Ethernet Modbus TCP in [I/O profile] <i>no</i> configuration
[C511]...[C515]	<i>C 511 C 515</i>	Virtual digital input CMD5.11...CMD5.15 with integrated Ethernet Modbus TCP regardless of configuration

**[External error] E E F - Menu****Access**

[Complete settings] → [Error/Warning handling] → [External error]

**[Ext Error Assign] E E F**

External error assignment.

If the assigned bit state is:

- 0: there is no external error.
- 1: there is an external error

Setting	Code / Value	Description
[Not Assigned]	n o	Not assigned <b>Factory setting</b>
[DI1]...[DI6]	L 1 L 1...L 1 6	Digital input DI1...DI6
[DI11]...[DI16]	L 1 1 1...L 1 1 6	Digital input DI11...DI16 if VW3A3203 I/O extension module has been inserted
[CD00]...[CD10]	C d 0 0...C d 1 0	Virtual digital input CMD.0...CMD.10 in <b>[I/O profile]</b> , o configuration
[CD11]...[CD15]	C d 1 1...C d 1 5	Virtual digital input CMD.11...CMD.15 regardless of configuration
[C100]...[C110]	C 1 0 0...C 1 1 0	Virtual digital input CMD1.0...CMD1.10 with integrated Modbus Serial in <b>[I/O profile]</b> , o configuration
[C111]...[C115]	C 1 1 1...C 1 1 5	Virtual digital input CMD1.11...CMD1.15 with integrated Modbus Serial regardless of configuration
[C200]...[C210]	C 2 0 0...C 2 1 0	Virtual digital input CMD2.0...CMD2.10 with CANopen® fieldbus module in <b>[I/O profile]</b> , o configuration
[C211]...[C215]	C 2 1 1...C 2 1 5	Virtual digital input CMD2.11...CMD2.15 with CANopen® fieldbus module regardless of configuration
[C300]...[C310]	C 3 0 0...C 3 1 0	Virtual digital input CMD3.0...CMD3.10 with a fieldbus module in <b>[I/O profile]</b> , o configuration
[C311]...[C315]	C 3 1 1...C 3 1 5	Virtual digital input CMD3.11...CMD3.15 with a fieldbus module regardless of configuration
[C500]...[C510]	C 5 0 0...C 5 1 0	Virtual digital input CMD5.0...CMD5.10 with integrated Ethernet Modbus TCP in <b>[I/O profile]</b> , o configuration
[C511]...[C515]	C 5 1 1...C 5 1 5	Virtual digital input CMD5.11...CMD5.15 with integrated Ethernet Modbus TCP regardless of configuration
[DI1 (Low level)]...[DI6 (Low level)]	L 1 L ...L 6 L	Digital input DI1...DI6 used at low level
[DI11 (Low level)]...[DI16 (Low level)]	L 1 1 L ...L 1 6 L	Digital input DI11...DI16 used at low level if VW3A3203 I/O extension module has been inserted

**[Ext Error Resp] E P L**

Drive response to external error.

Type of stop in the event of an external detected error.

Setting	Code / Value	Description
[Ignore]	n o	External detected error ignored
[Freewheel Stop]	4 E 5	Freewheel stop <b>Factory setting</b>
[Per STT]	5 E E	Stop according to configuration of <b>[Type of stop] 5 E E</b> ( <i>see page 542</i> ), without tripping. In this case, the detected error relay does not open and the drive is ready to restart as soon as the detected error disappears, according to the restart conditions of the active command channel (for example, according to <b>[2/3-wire control] E C C</b> and <b>[2-wire type] E C E</b> ( <i>see page 261</i> )) if control is via the terminals). Configuring a warning for this detected error is recommended (assigned to a digital output, for example) in order to indicate the cause of the stop.
[Fallback speed]	L F F	Change to fallback speed, maintained as long as the detected error persists and the run command has not been removed <sup>(1)</sup>
[Speed maintained]	r L 5	The drive maintains the speed being applied when the detected error occurred, as long as the detected error is active and the run command has not been removed <sup>(1)</sup>
[Ramp stop]	r P P	Stop on ramp
[Fast stop]	F 5 E	Fast stop
[DC Injection]	d C ,	DC injection stop. This type of stop cannot be used with some other functions.
(1) Because, in this case, the detected error does not trigger a stop, it is recommended to assign a relay or digital output to its indication.		





## [Output phase loss] $\alpha P L$ - Menu

### Access

[Complete settings] → [Error/Warning handling] → [Output phase loss]

### [OutPhaseLoss Assign] $\alpha P L$

Output phase loss assignment.

  **DANGER**

**HAZARD OF ELECTRIC SHOCK, EXPLOSION OR ARC FLASH**

If output phase monitoring is disabled, phase loss and, by implication, accidental disconnection of cables, are not detected.

- Verify that the setting of this parameter does not result in unsafe conditions.

**Failure to follow these instructions will result in death or serious injury.**

**NOTE:** [OutPhaseLoss Assign]  $\alpha P L$  is set to [Function Inactive]  $n \alpha$  when [Motor control type]  $C E E$  is set to [SYN\_U VC]  $S Y n u$ .

Setting	Code / Value	Description
[Function Inactive]	$n \alpha$	Function inactive
[OPF Error Triggered]	$Y E S$	Tripping on [OutPhaseLoss Assign] $\alpha P L$ with freewheel stop <b>Factory setting</b>
[No Error Triggered]	$\alpha R C$	No detected error triggered, but management of the output voltage in order to avoid an overcurrent when the link with the motor is re-established and catch on the fly performed (even if this function has not been configured). The drive switches to [Output cut] $S \alpha C$ state after [OutPhL Time] $\alpha d t$ time. Catch on fly is possible as soon as the drive is in stand by output cut [Output cut] $S \alpha C$ state.

### [OutPhaseLoss Delay] $\alpha d t$

Output (motor) phase loss detection time.

Time delay for taking the [OutPhaseLoss Assign]  $\alpha P L$  detected error into account.

Setting 	Description
0.5...10 s	Setting range <b>Factory setting:</b> 0.5 s

**[Input phase loss] , PL - Menu**

**Access**

[Complete settings] → [Error/Warning handling] → [Input phase loss]

**[InPhaseLoss Assign] , PL  **

Loss of input phase error response.

Setting	Code / Value	Description
[Ignore]	n o	Detected error ignored
[Freewheel Stop]	4 E 5	Freewheel stop <b>Factory setting</b>
[Per STT]	5 E E	Stop according to [Type of stop] 5 E E parameter but without an error triggered after stop
[Fallback Speed]	L F F	Change to fallback speed, maintained as long as the detected error persists and the run command has not been removed <sup>(1)</sup>
[Ramp stop]	r P P	Stop on ramp
<b>1</b> Because, in this case, the detected error does not trigger a stop, it is recommended to assign a relay or logic output to its indication.		

**[4-20mA loss] L F L - Menu****Access**

[Complete settings] → [Error/Warning handling] → [4-20mA loss]

**[AI1 4-20mA Loss] L F L I**

Response to 4-20mA loss on AI1.

Drive behavior on AI1 4-20 event.

Setting	Code / Value	Description
[Ignore]	n o	Detected error ignored. This is the only possible configuration if <b>[AI3 min. value] L r L 3</b> is not greater than 3 mA <b>Factory setting</b>
[Freewheel]	y e 5	Freewheel stop
[Per STT]	5 t t	Stop according to configuration of <b>[Type of stop] 5 t t</b> , without tripping. In this case, the error relay does not open and the drive is ready to restart as soon as the detected error disappears, according to the restart conditions of the active command channel (for example, according to <b>[2/3-wire control] t t t</b> and <b>[2-wire type] t t t</b> if control is via the terminals). Configuring a warning for this detected error is recommended (assigned to a digital output, for example) in order to indicate the cause of the stop
[fallback spd]	L F F	Change to fallback speed, maintained as long as the detected error persists and the run command has not been removed <sup>(1)</sup>
[Spd maint.]	r L 5	The drive maintains the speed being applied when the detected error occurred, as long as the detected error is active and the run command has not been removed <sup>(1)</sup>
[Ramp stop]	r P P	Stop on ramp
[Fast stop]	F 5 t	Fast stop
[DC injection]	d C i	DC injection stop. This type of stop cannot be used with some other functions

(1) Because, in this case, the detected error does not trigger a stop, it is recommended to assign a relay or digital output to its indication.

**[AI2 4-20mA loss] L F L 2**

Response to 4-20mA loss on AI2.

Drive behavior on AI2 4-20 event.

Identical to **[AI1 4-20mA Loss] L F L I**

**[AI3 4-20mA loss] L F L 3**

Response to 4-20mA loss on AI3.

Drive behavior on AI3 4-20 event.

Identical to **[AI1 4-20mA Loss] L F L I**

**[AI4 4-20mA loss] L F L 4★**

Response to 4-20mA loss on AI4.

Drive behavior on AI4 4-20 event.

Identical to **[AI1 4-20mA Loss] L F L I**

This parameter can be accessed if VW3A3203 I/O extension module has been inserted.

**[AI5 4-20mA loss] L F L 5★**

Response to 4-20mA loss on AI5.

Drive behavior on AI5 4-20 event.

Identical to **[AI1 4-20mA Loss] L F L I**

This parameter can be accessed if VW3A3203 I/O extension module has been inserted.

## [Fallback speed] L F F - Menu

### Access

[Complete settings] → [Error/Warning handling] → [Fallback speed]

### [Fallback Speed] L F F

Fall back speed.

Setting	Description
0.0...500.0 Hz	Setting range <b>Factory setting:</b> 0.0 Hz

**[Fieldbus monitoring] L L L - Menu****Access**

[Complete settings] → [Error/Warning handling] → [Fieldbus monitoring]

**[Modbus Error Resp] S L L**

Stop mode at Modbus SLF.

## ⚠ WARNING

**LOSS OF CONTROL**

If this parameter is set to **n o**, Modbus communication monitoring is disabled.

- Only use this setting after a thorough risk assessment in compliance with all regulations and standards that apply to the device and to the application.
- Only use this setting for tests during commissioning.
- Verify that communication monitoring has been re-enabled before completing the commissioning procedure and performing the final commissioning test.

**Failure to follow these instructions can result in death, serious injury, or equipment damage.**

Behavior of the drive in the event of a communication interruption with integrated Modbus.

Setting	Code / Value	Description
[Ignore]	<b>n o</b>	Detected error ignored
[Freewheel]	<b>Y E S</b>	Freewheel stop <b>Factory setting</b>
[Per STT]	<b>S E E</b>	Stop according to configuration of [Type of stop] <b>S E E</b> , without tripping. In this case, the error relay does not open and the drive is ready to restart as soon as the detected error disappears, according to the restart conditions of the active command channel (for example, according to [2/3-wire control] <b>E E E</b> and [2-wire type] <b>E E E</b> if control is via the terminals) <sup>(1)</sup>
[fallback spd]	<b>L F F</b>	Change to fallback speed, maintained as long as the detected error persists and the run command has not been removed <sup>(1)</sup>
[Spd maint.]	<b>r L S</b>	The drive maintains the speed being applied when the detected error occurred, as long as the detected error is active and the run command has not been removed <sup>(1)</sup>
[Ramp stop]	<b>r P P</b>	Stop on ramp
[Fast stop]	<b>F S E</b>	Fast stop
[DC injection]	<b>d C i</b>	DC injection stop. This type of stop cannot be used with some other functions
(1) Because, in this case, the detected error does not trigger a stop, it is recommended to assign a relay or digital output to its indication.		

**[Embedded Modbus TCP] E Π E C - Menu**

**Access**

[Complete settings] → [Error/Warning handling] → [Embedded Modbus TCP]

**[Eth Error Response] E E H L**

<b>⚠ WARNING</b>
<p><b>LOSS OF CONTROL</b></p> <p>If this parameter is set to <i>n o</i>, Ethernet communication monitoring is disabled.</p> <ul style="list-style-type: none"> <li>● Only use this setting after a thorough risk assessment in compliance with all regulations and standards that apply to the device and to the application.</li> <li>● Only use this setting for tests during commissioning.</li> <li>● Verify that communication monitoring has been re-enabled before completing the commissioning procedure and performing the final commissioning test.</li> </ul> <p><b>Failure to follow these instructions can result in death, serious injury, or equipment damage.</b></p>

Ethernet error response.

Setting	Code / Value	Description
<b>[Ignore]</b>	<i>n o</i>	Detected error ignored
<b>[Freewheel Stop]</b>	<i>Y E S</i>	Freewheel stop <b>Factory setting</b>
<b>[Per STT]</b>	<i>S E E</i>	Stop according to <b>[Type of stop] S E E</b> parameter but without an error triggered after stop
<b>[Fallback Speed]</b>	<i>L F F</i>	Change to fallback speed, maintained as long as the detected error persists and the run command has not been removed <sup>(1)</sup>
<b>[Ramp stop]</b>	<i>r P P</i>	Stop on ramp
<p><b>1</b> Because, in this case, the detected error does not trigger a stop, it is recommended to assign a relay or logic output to its indication.</p>		

## [Communication module] $\llcorner \square \Pi \square$ - Menu

### Access

[Complete settings] → [Error/Warning handling] → [Communication module]

### [Fieldbus Interrupt Resp] $\llcorner \llcorner \llcorner$

## WARNING

### LOSS OF CONTROL

If this parameter is set to  $n \square$ , fieldbus communication monitoring is disabled.

- Only use this setting after a thorough risk assessment in compliance with all regulations and standards that apply to the device and to the application.
- Only use this setting for tests during commissioning.
- Verify that communication monitoring has been re-enabled before completing the commissioning procedure and performing the final commissioning test.

**Failure to follow these instructions can result in death, serious injury, or equipment damage.**

Response to fieldbus module communication interruption.

Setting	Code / Value	Description
[Ignore]	$n \square$	Detected error ignored
[Freewheel Stop]	$Y E S$	Freewheel stop <b>Factory setting</b>
[Per STT]	$S E E$	Stop according to [Type of stop] $S E E$ parameter but without an error triggered after stop
[Fallback Speed]	$L F F$	Change to fallback speed, maintained as long as the detected error persists and the run command has not been removed <sup>(1)</sup>
[Ramp stop]	$r \Pi P$	Stop on ramp

**1** Because, in this case, the detected error does not trigger a stop, it is recommended to assign a relay or logic output to its indication.

[CANopen Error Resp] *L 0 L*

<b>⚠ WARNING</b>
<p><b>LOSS OF CONTROL</b></p> <p>If this parameter is set to <i>n 0</i>, CANopen communication monitoring is disabled.</p> <ul style="list-style-type: none"> <li>● Only use this setting after a thorough risk assessment in compliance with all regulations and standards that apply to the device and to the application.</li> <li>● Only use this setting for tests during commissioning.</li> <li>● Verify that communication monitoring has been re-enabled before completing the commissioning procedure and performing the final commissioning test.</li> </ul> <p><b>Failure to follow these instructions can result in death, serious injury, or equipment damage.</b></p>

Response to CANopen error.

Behavior of the drive in the event of a communication interruption with CANopen®.

Setting	Code / Value	Description
<b>[Ignore]</b>	<i>n 0</i>	Detected error ignored
<b>[Freewheel Stop]</b>	<i>5 E 5</i>	Freewheel stop <b>Factory setting</b>
<b>[Per STT]</b>	<i>5 E E</i>	Stop according to <b>[Type of stop]</b> <i>5 E E</i> parameter but without an error triggered after stop
<b>[Fallback Speed]</b>	<i>L F F</i>	Change to fallback speed, maintained as long as the detected error persists and the run command has not been removed <sup>(1)</sup>
<b>[Ramp stop]</b>	<i>r P P</i>	Stop on ramp
<p><b>1</b> Because, in this case, the detected error does not trigger a stop, it is recommended to assign a relay or logic output to its indication.</p>		



## [Undervoltage handling] ↪ 5 b - Menu

### Access

[Complete settings] → [Error/Warning handling] → [Undervoltage handling]

### [Undervoltage Resp] ↪ 5 b

Response to undervoltage.

Setting	Code / Value	Description
[Error Triggered]	0	The drive trips and the external detected error signal are triggered (the detected error relay assigned to <b>[Operating State Fault] F L E</b> will be opened) <b>Factory setting</b>
[Error Triggered w/o Relay]	1	The drive trips but the external detected error signal is not triggered (the detected error relay assigned to <b>[Operating State Fault] F L E</b> remains closed)
[Warning Triggered]	2	The warning and detected error relay remain closed. The warning can be assigned to a digital output or a relay

### [Mains Voltage] ↪ r E 5

Rated voltage of the mains supply in Vac.

Settings	Code / Value	Description
[200 Vac]	2 0 0	200 Vac
[220 Vac]	2 2 0	220 Vac
[230 Vac]	2 3 0	230 Vac
[240 Vac]	2 4 0	240 Vac
[380 Vac]	3 8 0	380 Vac
[400 Vac]	4 0 0	400 Vac
[415 Vac]	4 1 5	415 Vac
[440 Vac]	4 4 0	440 Vac
[460 Vac]	4 6 0	460 Vac
[480 Vac]	4 8 0	480 Vac
[525 Vac]	5 2 5	525 Vac
[575 Vac]	5 7 5	575 Vac
[600 Vac]	6 0 0	600 Vac
[690 Vac]	6 9 0	690 Vac <b>Factory setting</b>

### [Undervoltage Level] ↪ 5 L

Undervoltage level.

The factory setting is determined by the drive voltage rating.

Setting	Description
100...345 V	Setting range, according to drive rating <b>Factory setting:</b> According to drive rating

### [UnderVolt Timeout] ↪ 5 E

Undervoltage timeout.

Setting	Description
0.2...999.9 s	Setting range <b>Factory setting:</b> 0.2 s

**[CtrlStopPLoss] 5 E P**

Controlled stop on power loss.

Behavior in the event of the undervoltage prevention level being reached.

Setting	Code / Value	Description
[No]	n o	No action <b>Factory setting</b>
[DC Maintain]	π π 5	This stop mode uses the inertia of the application to maintain the control block powered, and thus to keep operational I/O state and fieldbus link as long as possible.
[Ramp stop]	r π P	Stop following an adjustable deceleration ramp <b>[Max stop time] 5 E π</b> in order to help to prevent from uncontrolled stop of the application.
[Freewheel Stop]	L n F	Lock (freewheel stop) without triggering an error

**[UnderV. Restart Tm] E 5 π ★**

Undervoltage restart time.

This parameter can be accessed if **[CtrlStopPLoss] 5 E P** is set to **[Ramp stop] r π P**.

The time delay before authorizing the restart after a complete stop for **[CtrlStopPLoss] 5 E P** is set to **[Ramp stop] r π P** if the voltage has returned to normal.

Setting ( )	Description
1.0...999.9 s	Setting range <b>Factory setting:</b> 1.0 s

**[Prevention Level] u P L ★**

Undervoltage prevention level.

This parameter can be accessed if **[CtrlStopPLoss] 5 E P** is set to **[No] n o**.

The adjustment range and factory setting are determined by the drive voltage rating and the **[Mains Voltage] u r E 5** value.

Setting	Description
141...414 V	Setting range <b>Factory setting:</b> According to drive rating

**[Max Stop Time] 5 E π ★**

Maximum stop time.

This parameter can be accessed if **[CtrlStopPLoss] 5 E P** is set to **[Ramp stop] r π P**.

This parameter defines the deceleration ramp time in case of mains loss. During this controlled stop, the drive is powered thanks to the inertia of the application, the motor is in generator mode. It is recommended to verify that the deceleration set is compatible with the application inertia.

Setting ( )	Description
0.01...60.00 s	Setting range <b>Factory setting:</b> 1.00 s

**[DC Bus Maintain Time] E b 5 ★**

DC bus maintain time.

This parameter can be accessed if **[CtrlStopPLoss] 5 E P** is set to **[DC Maintain] π π 5**.

Setting ( )	Description
1...9999 s	Setting range <b>Factory setting:</b> 9999 s

**[Ground Fault] *G r F L* - Menu****Access**

[Complete settings] → [Error/Warning handling] → [Ground Fault]

**About This Menu****[Ground Fault Activation] *G r F L***

Ground fault error response.

Setting	Code / Value	Description
[ErrorDetect Disable]	<i>i n H</i>	Disables error detection
[Yes]	<i>Y E 5</i>	Use product internal value <b>Factory setting</b>
0.0...100.0%	–	Setting range, in % of the drive nominal current

**[Warn grp 1 definition] R I C - Menu****Access**

**[Complete settings] → [Error/Warning handling] → [Warning groups config] → [Warn grp 1 definition]**

**About This Menu**

The following submenus group the warnings into 1 to 5 groups, each of which can be assigned to a relay or a digital output for remote signaling.

When one or a number of warnings selected in a group occur, this warning group is activated.

**List of Warnings**

Setting	Code / Value	Description
[Fallback Frequency]	<i>F r F</i>	Fallback frequency
[Speed Maintained]	<i>r L S</i>	Speed maintained
[Type of stop]	<i>S t t</i>	Type of stop
[Ref Frequency Warning]	<i>S r R</i>	Reference frequency warning
[Life Cycle Warn 1]	<i>L C R 1</i>	Life cycle warning 1
[Life Cycle Warn 2]	<i>L C R 2</i>	Life cycle warning 2
[Drive Running Warning]	<i>d r Y R</i>	Drive running warning
[Low Flow Warning]	<i>L F R</i>	Low flow warning
[High Flow Warning]	<i>H F P R</i>	High flow warning
[InPress Warning]	<i>i P P R</i>	Inlet pressure warning
[Low OutPres Warning]	<i>o P L R</i>	Low OutPres warning
[High OutPres Warning]	<i>o P H R</i>	High OutPres warning
[Pump Cycle warning]	<i>P C P R</i>	Pumpcycle warning
[Anti-Jam Warning]	<i>J A N R</i>	Anti-Jam warning
[Pump Low Flow Warn]	<i>P L F R</i>	Pump low flow warning
[LowPres Warning]	<i>L P R</i>	LowPres warning
[Flow Limit Activated]	<i>F S R</i>	Flow limit activated
[PID Error Warning]	<i>P E E</i>	PID error warning
[PID Feedback Warning]	<i>P F R</i>	PID feedback warning
[PID High Fdbck Warning]	<i>P F R H</i>	PID high warning
[PID Low Fdbck Warning]	<i>P F R L</i>	PID low warning
[Regulation Warning]	<i>P i S H</i>	Regulation warning
[AI2 Th Warning]	<i>t P 2 R</i>	AI2 thermal sensor warning
[AI3 Th Warning]	<i>t P 3 R</i>	AI3 thermal sensor warning
[AI4 Th Warning]	<i>t P 4 R</i>	AI4 thermal sensor warning
[AI5 Th Warning]	<i>t P 5 R</i>	AI5 thermal sensor warning
[AI1 4-20 Loss Warning]	<i>R P 1</i>	AI1 4-20 loss warning
[AI2 4-20 Loss Warning]	<i>R P 2</i>	AI2 4-20 loss warning
[AI3 4-20 Loss Warning]	<i>R P 3</i>	AI3 4-20 loss warning
[AI4 4-20 Loss Warning]	<i>R P 4</i>	AI4 4-20 loss warning
[AI5 4-20 Loss Warning]	<i>R P 5</i>	AI5 4-20 loss warning
[Drive Thermal Warning]	<i>t H R</i>	Drive thermal state warning
[IGBT Thermal Warning]	<i>t J R</i>	IGBT thermal warning
[Fan Counter Warning]	<i>F C t R</i>	Fan counter warning
[Fan Feedback Warning]	<i>F F d R</i>	Fan feedback warning
[Ext. Error Warning]	<i>E F R</i>	External error warning
[Undervoltage Warning]	<i>u S R</i>	Undervoltage warning
[Preventive UnderV Active]	<i>u P R</i>	Preventive undervoltage active

Setting	Code / Value	Description
[Motor Freq High Thd]	<i>F L R</i>	Motor frequency high threshold reached
[Motor Freq Low Thd]	<i>F L R L</i>	Motor frequency low threshold reached
[Motor Freq Low Thd 2]	<i>F 2 R L</i>	Motor frequency low threshold 2 reached
[High speed reached]	<i>F L R</i>	High speed reached
[Ref Freq High Thd]	<i>r L R H</i>	Ref freq high Thd
[Ref Freq Low Thd]	<i>r L R L</i>	Ref freq low Thd
[2nd Frequency Thd Reached]	<i>F 2 R</i>	Second frequency threshold reached
[Current Thd Reached]	<i>C L R</i>	Current threshold reached
[Low Current Reached]	<i>C L R L</i>	Low Current Reached
[Process Undld Warning]	<i>u L R</i>	Process underload warning
[Process Overload Warning]	<i>o L R</i>	Process overload warning
[Drv Therm Thd reached]	<i>t R d</i>	Drive thermal threshold reached
[Motor Therm Thd Reached]	<i>t S R</i>	Motor thermal threshold reached
[Power High Threshold]	<i>P L H R</i>	Power High Threshold
[Power Low Threshold]	<i>P L H L</i>	Power Low Threshold
[Cust Warning 1]	<i>C R S 1</i>	Customer Warning 1
[Cust Warning 2]	<i>C R S 2</i>	Customer Warning 2
[Cust Warning 3]	<i>C R S 3</i>	Customer Warning 3
[Cust Warning 4]	<i>C R S 4</i>	Customer Warning 4
[Cust Warning 5]	<i>C R S 5</i>	Customer Warning 5
[Power Cons Warning]	<i>P o W d</i>	Power consumption warning
[Switch OutPres Warning]	<i>o P S R</i>	Switch OutPres warning
[Ethernet Internal Warning]	<i>i n W n</i>	Ethernet internal warning
[MultiPump Capacity Warn]	<i>n P c R</i>	Multi-Pump available capacity warning
[Lead Pump Warn]	<i>n P L R</i>	Lead Pump not available
[High Level Warning]	<i>L c h R</i>	High level warning
[Low Level Warning]	<i>L c h R</i>	Low level warning
[Level Switch Warning]	<i>L c W R</i>	Level switch warning

## [Warn grp 2 definition] *A 2 C* - Menu

### Access

[Complete settings] → [Error/Warning handling] → [Warning groups config] → [Warn grp 2 definition]

### About This Menu

Identical to [Warn grp 1 definition] *A 1 C* (*see page 692*)

---

## [Warn grp 3 definition] *A 3 C* - Menu

### Access

[Complete settings] → [Error/Warning handling] → [Warning groups config] → [Warn grp 3 definition]

### About This Menu

Identical to [Warn grp 1 definition] *A 1 C* (*see page 692*)

## **[Warn grp 4 definition] *A 4 C* - Menu**

### **Access**

[Complete settings] → [Error/Warning handling] → [Warning groups config] → [Warn grp 4 definition]

### **About This Menu**

Identical to [Warn grp 1 definition] *A 1 C* (*see page 692*)



## [Warn grp 5 definition] *A 5 C* - Menu

### Access

[Complete settings] → [Error/Warning handling] → [Warning groups config] → [Warn grp 5 definition]

### About This Menu

Identical to [Warn grp 1 definition] *A 1 C* (*see page 692*)

## Section 7.55

### [Maintenance]

#### What Is in This Section?

This section contains the following topics:

Topic	Page
[Diagnostics] <i>dR u</i> - Menu	699
[Drive warranty mgnt] <i>dW nA</i> - Menu	700
[Customer event 1] <i>CE 1</i> - Menu	701
[Customer event 2] <i>CE 2</i> - Menu	702
[Customer event 3] <i>CE 3</i> - Menu	703
[Customer event 4] <i>CE 4</i> - Menu	704
[Customer event 5] <i>CE 5</i> - Menu	705
[Customer events] <i>CE V</i> - Menu	706
[Fan management] <i>F nA</i> - Menu	707
[Maintenance] <i>CS nA</i> - Menu	708

## [Diagnostics] *d R U* - Menu

### Access

[Complete settings] → [Maintenance] → [Diagnostics]

### About This Menu

This menu allows you to make simple test sequences for diagnostics.

### [FAN Diagnostics] *F n t*

Diagnostics of internal fan(s).

This starts a test sequence.

### [LED Diagnostics] *H L t*

Diagnostics of product LED(s).

This starts a test sequence.

### [IGBT Diag w motor] *i W t*

Diagnostics of internal fan(s).

This starts a test sequence with the motor (open circuit/short-circuit).

### [IGBT Diag w/o motor] *i W o t*

Diagnostics of product IGBT(s).

This starts a test sequence without the motor (short-circuit).

## [Drive warranty mgnt] *dWnR* - Menu

### Access

[Complete settings] → [Maintenance] → [Drive warranty mgnt]

### About This Menu

The product life cycle date is initialized during product manufacturing.

A [Life Cycle Warn 1] *L C R 1* is triggered 2 months before the end of the warranty period. At the end of the warranty period a [Life Cycle Warn 2] *L C R 2* is triggered. This function requires date and time data coming from Graphic Display Terminal or a time server configured trough Ethernet.

### [LifeCycle Warning] *L C R C*

Life cycle warning configuration.

Setting ( )	Code / Value	Description
[No]	<i>n o</i>	No
[YES]	<i>Y E S</i>	Yes Factory setting

### [Warranty Expired] *L C R d*

Life cycle date.

End of warranty date (YYYY/MM/DD).

Setting	Description
YYYY/MM/DD	Setting range Factory setting: _

## [Customer event 1] [ C E I - Menu

### Access

[Complete settings] → [Maintenance] → [Customer events] → [Customer event 1]

### About This Menu

This menu allows you to define customized customer events based on the time.

## [Config Warning 1] [ C C R I

Configuration of customer warning 1.

Setting	Code / Value	Description
[Not Configured]	n o	Not configured <b>Factory setting</b>
[Counter]	C P t	Counter
[Date And Time]	d t	Date and time

## [Counter Limit 1] [ C C L I

Configuration counter limit 1.

Setting	Description
0...4294967295 s	Setting range <b>Factory setting:</b> 0 s

## [Counter Source 1] [ C C S I

Configuration counter source 1.

Setting	Code / Value	Description
[Mains/Control ON]	0	Mains or control supply on
[Mains Supply ON]	1	Mains supply on
[Drv In Run State]	2	Drive in running state <b>Factory setting</b>

## [Current Counter 1] [ C C I

Current counter 1.

Setting	Description
0...4294967295 s	Setting range <b>Factory setting:</b> 0 s

## [Date Time Warn 1] [ C d t I ★

Date time warning 1.

This parameter can be accessed with the Graphic Display Terminal only.

Setting ( )	Description
hh:mm DD/MM/YYYY	Setting range <b>Factory setting:</b> 00:00 01/01/2000

## [Customer event 2] *CE2* - Menu

### Access

[Complete settings] → [Maintenance] → [Customer events] → [Customer event 2]

### About This Menu

Identical to [Customer event 1] *CE1* - menu (*see page 701*).

### [Config Warning 2] *CCR2*

Configuration of customer warning 2.

### [Counter Limit 2] *CLL2*

Configuration counter limit 2.

### [Counter Source 2] *CLS2*

Configuration counter source 2.

### [Current Counter 2] *CC2*

Current counter 2.

### [Date Time Warn 2] *DTW2* ★

Date time warning 2.

This parameter can be accessed with the Graphic Display Terminal only.

## [Customer event 3] [ E 3 ] - Menu

### Access

[Complete settings] → [Maintenance] → [Customer events] → [Customer event 3]

### About This Menu

Identical to [Customer event 1] [ E 1 ] - menu (*see page 701*).

### [Config Warning 3] [ C R 3 ]

Configuration of customer warning 3.

### [Counter Limit 3] [ C L 3 ]

Configuration counter limit 3.

### [Counter Source 3] [ C S 3 ]

Configuration counter source 3.

### [Current Counter 3] [ C 3 ]

Current counter 3.

### [Date Time Warn 3] [ D T 3 ] ★

Date time warning 3.

This parameter can be accessed with the Graphic Display TerminalGraphic display terminal only.

## [Customer event 4] *C E 4* - Menu

### Access

[Complete settings] → [Maintenance] → [Customer events] → [Customer event 4]

### About This Menu

Identical to [Customer event 1] *C E 1* - menu (*see page 701*).

### [Config Warning 4] *C C R 4*

Configuration of customer warning 4.

### [Counter Limit 4] *C C L 4*

Configuration counter limit 4.

### [Counter Source 4] *C C S 4*

Configuration counter source 4.

### [Current Counter 4] *C C 4*

Current counter 4.

### [Date Time Warn 4] *C D T 4* ★

Date time warning 4.

This parameter can be accessed with the Graphic Display Terminal/Graphic display terminal only.



## [Customer event 5] *CE5* - Menu

### Access

[Complete settings] → [Maintenance] → [Customer events] → [Customer event 5]

### About This Menu

Identical to [Customer event 1] *CE1* - menu (*see page 701*).

### [Config Warning 5] *CCR5*

Configuration of customer warning 5.

### [Counter Limit 5] *CLL5*

Configuration counter limit 5.

### [Counter Source 5] *CLS5*

Configuration counter source 5.

### [Current Counter 5] *CC5*

Current counter 5.

### [Date Time Warn 5] *DTL5* ★

Date time warning 5.

This parameter can be accessed with the Graphic Display Terminal only.

**[Customer events] [ E V - Menu****Access**

[Complete settings] → [Maintenance] → [Customer events]

**[Warning Clearing] [ R r**

Customer warning clearing.

Setting ( )	Code / Value	Description
[No Warning Clearing]	n o	No warning clearing <b>Factory setting</b>
[Clear Event 1 Warning]	r R 1	Clear event 1 warning
[Clear Event 2 Warning]	r R 2	Clear event 2 warning
[Clear Event 3 Warning]	r R 3	Clear event 3 warning
[Clear Event 4 Warning]	r R 4	Clear event 4 warning
[Clear Event 5 Warning]	r R 5	Clear event 5 warning

## [Fan management] *F A N A* - Menu

### Access

[Complete settings] → [Maintenance] → [Fan management]

### About This Menu

Fan speed and [Fan Operation Time] *F P b t* are monitored values.

An abnormal low speed or the fan trigger a warning [Fan Feedback Warning] *F F d A*. As soon as [Fan Operation Time] *F P b t* reach the predefined value of 45,000 hours, a warning [Fan Counter Warning] *F C t A* is triggered.

[Fan Operation Time] *F P b t* counter can be set to 0 by using the [Counter Reset] *r P r* parameter.

### [Fan Mode] *F F n*

Fan activation mode.

Setting ( )	Code / Value	Description
[Standard]	<i>S t d</i>	The fan is activated during the all run time of the motor. According to the drive rating, this could be the only available setting <b>Factory setting</b>
[Always]	<i>r u n</i>	The fan is always activated
[Economy]	<i>E c o</i>	The fan is activated only if necessary, according to the internal thermal state of the drive

**[Maintenance] C S P A - Menu****Access****[Complete settings] → [Maintenance]****[Counter Reset] r P r**

Counter reset.

Setting ( )	Code / Value	Description
[No]	n a	No <b>Factory setting</b>
[Run Time Reset]	r t H	Run time reset
[Power ON Time Reset]	P t H	Power ON time reset
[Reset Fan Counter]	F t H	Reset fan counter
[Clear NSM]	n S n	Number of motor starts
[Efficiency MAX]	E F y K	Efficiency max
[Efficiency MIN]	E F y J	Efficiency min
[Flow Rate MAX]	F S I K	Flow rate max
[Flow Rate MIN]	F S I J	Flow rate min
[Reset Total Quantity]	F S I C	Reset total quantity

---

# Chapter 8

## [Communication] C o N -

---

### Introduction



[Communication] C o N - menu presents the fieldbus submenus.

### What Is in This Chapter?

This chapter contains the following topics:

Topic	Page
[Modbus Fieldbus] M d I - Menu	710
[Com. scanner input] , C S - Menu	712
[Com. scanner output] o C S - Menu	713
[Modbus HMI] M d 2 - Menu	714
[Embd Eth Config] E t E - Menu	715
[Eth Module Config] E t o - Menu	716
[CANopen] C n o - Menu	717
[DeviceNet] d n C - Menu	718
[Profibus] P b C - Menu	719
[Profinet] P n C - Menu	720
[Communication] C o N - Menu	721

## [Modbus Fieldbus] *Π d l* - Menu

### Access

[Communication] → [Comm parameters] → [Modbus SL] → [Modbus Fieldbus]

### About This Menu

This menu is related to the Modbus serial communication port on the bottom of the control block. Refer to the Modbus serial manual.

### [Modbus Address] *Π d d*

Drive Modbus address.

Setting	Description
[OFF] <i>α F F</i> ...247	Setting range <b>Factory setting:</b> [OFF] <i>α F F</i>

### [Bd.RateModbus] *ε b r*

Baud rate Modbus.

Setting	Code / Value	Description
[4800 bps]	<i>4 K B</i>	4,800 Bauds
[9600 bps]	<i>9 K B</i>	9,600 Bauds
[19200 bps]	<i>1 9 K 2</i>	19,200 Bauds <b>Factory setting</b>
[38.4 Kbps]	<i>3 8 K 4</i>	38,400 Bauds

### [Term Word Order] *ε W α* ★

Terminal Modbus: word order.

This parameter can be accessed if [Access Level] *L R C* is set to [Expert] *E P r*.

Setting	Code / Value	Description
[OFF]	<i>α F F</i>	Low word first
[ON]	<i>α n</i>	High word first <b>Factory setting</b>

### [Modbus Format] *ε F α*

Modbus communication format.

Setting	Code / Value	Description
[8-O-1]	<i>B α l</i>	8 bits odd parity 1 stop bit
[8-E-1]	<i>B E l</i>	8 bits even parity 1 stop bit <b>Factory setting</b>
[8-N-1]	<i>B n l</i>	8 bits no parity 1 stop bit
[8-N-2]	<i>B n 2</i>	8 bits no parity 2 stop bits

### [Modbus Timeout] *ε ε α*

Modbus timeout.

Setting	Description
0.1 ...30.0 s	Setting range <b>Factory setting:</b> 10.s

**[Mdb Com Stat] *□ □ □ □***

Modbus communication status.

Setting	Code / Value	Description
[r0t0]	<i>r 0 t 0</i>	Modbus no reception, no transmission
[r0t1]	<i>r 0 t 1</i>	Modbus no reception, transmission
[r1t0]	<i>r 1 t 0</i>	Modbus reception, no transmission
[r1t1]	<i>r 1 t 1</i>	Modbus reception and transmission

**[Com. scanner input] , [ 5 - Menu**

**Access**

[Communication] → [Comm parameters] → [Modbus SL] → [Modbus Fieldbus] → [Com. scanner input]

**[Scan. IN1 address] n P A 1**

Address of the first input word.

Setting	Description
0...65535	Setting range Factory setting: 3201 (E L A)

**[Scan. IN2 address] n P A 2**

Address of the second input word.

Setting	Description
0...65535	Setting range Factory setting: 8604 (r F r d)

**[Scan. IN3 address] n P A 3**

Address of the third input word.

Setting	Description
0...65535	Setting range Factory setting: 0

**[Scan. IN4 address] n P A 4**

Address of the fourth input word.

Identical to [Scan. IN3 address] n P A 3.

**[Scan. IN5 address] n P A 5**

Address of the fifth input word.

Identical to [Scan. IN3 address] n P A 3.

**[Scan. IN6 address] n P A 6**

Address of the sixth input word.

Identical to [Scan. IN3 address] n P A 3.

**[Scan. IN7 address] n P A 7**

Address of the seventh input word.

Identical to [Scan. IN3 address] n P A 3.

**[Scan. IN8 address] n P A 8**

Address of the eighth input word.

Identical to [Scan. IN3 address] n P A 3.



## [Com. scanner output] ▢ [ 5 - Menu

### Access

[Communication] → [Comm parameters] → [Modbus SL] → [Modbus Fieldbus] → [Com. scanner output]

### [Scan.Out1 address] *n C R 1*

Address of the first output word.

Setting	Description
0...65535	Setting range Factory setting: 8501( <i>C P d</i> )

### [Scan.Out2 address] *n C R 2*

Address of the second output word.

Setting	Description
0...65535	Setting range Factory setting: 8602( <i>L F r d</i> )

### [Scan.Out3 address] *n C R 3*

Address of the third output word.

Setting	Description
0...65535	Setting range Factory setting: 0

### [Scan.Out4 address] *n C R 4*

Address of the fourth output word.

Identical to **[Scan.Out3 address]** *n C R 3*.

### [Scan.Out5 address] *n C R 5*

Address of the fifth output word.

Identical to **[Scan.Out3 address]** *n C R 3*.

### [Scan.Out6 address] *n C R 6*

Address of the sixth output word.

Identical to **[Scan.Out3 address]** *n C R 3*.

### [Scan.Out7 address] *n C R 7*

Address of the seventh output word.

Identical to **[Scan.Out3 address]** *n C R 3*.

### [Scan.Out8 address] *n C R 8*

Address of the eighth output word.

Identical to **[Scan.Out3 address]** *n C R 3*.

**[Modbus HMI] П д 2 - Menu**

**Access**

[Communication] → [Comm parameters] → [Modbus SL] → [Modbus HMI]

**About This Menu**

This menu is related to the Modbus serial communication port on the front of the control block. It is used by default for the Graphic Display Terminal. The Graphic Display Terminal is compliant with baud rate equal to or lower than 19,200 bps.

**[HMI Baud Rate] Ё б р 2**

Baud rate Modbus.

Setting	Code / Value	Description
[4800 bps]	4 K B	4,800 Bauds
[9600 bps]	9 K Б	9,600 Bauds
[19200 bps]	19 K 2	19,200 Bauds <b>Factory setting</b>
[38.4 Kbps]	38 K Ч	38,400 Bauds

**[Term 2 word order] Ё W о 2 ★**

Terminal Modbus 2: Word order.

This parameter can be accessed if [Access Level] L P C is set to [Expert] E P P .

Setting	Code / Value	Description
[LOW]	о F F	Low word first
[HIGH]	о n	High word first <b>Factory setting</b>

**[HMI Format] Ё F о 2**

HMI format.

Setting	Code / Value	Description
[8-O-1]	В о 1	8.o.1.
[8-E-1]	В E 1	8.E.1. <b>Factory setting</b>
[8-N-1]	В n 1	8.n.1.
[8-N-2]	В n 2	8.n.2.

**[Mdb com start] C о П 2**

Modbus communication status.

Setting	Code / Value	Description
[r0t0]	р 0 Ё 0	Modbus no reception, no transmission
[r0t1]	р 0 Ё 1	Modbus no reception, transmission
[r1t0]	р 1 Ё 0	Modbus reception, no transmission
[r1t1]	р 1 Ё 1	Modbus reception and transmission

## [Embd Eth Config] E E E - Menu

### Access

[Communication] → [Comm parameters] → [Embd Eth Config]

### About This Menu

Refer to the Ethernet embedded manual.

### [Device Name] P P n

The FDR (Fast Device Replacement) service is based on identification of the device by a "Device Name". In the case of the Altivar drive, this is represented by the **[Device Name] P P n** parameter. Check that all the network devices have different "Device Names".

### [IP Mode Ether. Embd] , n o o

IP mode Ethernet embedded.

Setting ( )	Code / Value	Description
[Fixed]	<i>n P n u</i>	Fixed address
[BOOTP]	<i>b o o t P</i>	BOOTP
[DHCP]	<i>d H C P</i>	DHCP <b>Factory setting</b>

### [IP address] , C o

IP Address ( , C o 1, , C o 2, , C o 3, , C o 4).

Setting	Description
0...255	Setting range <b>Factory setting:</b> 0.0.0.0

### [Mask] , n o

Subnet mask ( , n o 1, , n o 2, , n o 3, , n o 4).

Setting	Description
0...255	Setting range <b>Factory setting:</b> 0.0.0.0

### [Gateway] , G o

Gateway address ( , G o 1, , G o 2, , G o 3, , G o 4).

Setting	Description
0...255	Setting range <b>Factory setting:</b> 0.0.0.0

## **[Eth Module Config] E L D - Menu**

### **Access**

**[Communication] → [Comm parameters] → [Eth Module Config]**

### **About This Menu**

Refer to the Ethernet-IP Modbus TCP fieldbus module manual.

---

## [CANopen] [ n o ] - Menu

### Access

[Communication] → [Comm parameters] → [CANopen]

### About This Menu

Refer to the CANopen fieldbus module manual.

## [DeviceNet] d n C - Menu

### Access

[Communication] → [Comm parameters] → [DeviceNet]

### About This Menu

Refer to the DeviceNet fieldbus module manual.

## **[Profibus] P b C - Menu**

### **Access**

**[Communication] → [Comm parameters] → [Profibus]**

### **About This Menu**

Refer to the Profibus DP fieldbus module manual.

## [Profinet] P n C - Menu

### Access

[Communication] → [Comm parameters] → [Profinet]

### About This Menu

Refer to the PROFINET fieldbus module manual.



## [Communication] $\square$ $\square$ $\square$ - Menu

### Access

#### [Communication]

### [Go to Multipoint Screen] $\square$ $\square$ $\square$

Communication is possible between a Graphic Display Terminal and a number of drives connected on the same Modbus serial fieldbus. The addresses of the drives must be configured in advance in the **[Communication]  $\square$   $\square$   $\square$**  - menu using the **[Modbus Address]  $\square$   $\square$   $\square$**  parameter.

When a number of drives are connected to the same Graphic Display Terminal, the terminal automatically displays the list of the drives connected, sorted by Modbus addresses. It is possible to scroll the list and to display in full screen the selected drive by pressing the **OK** key. **ESC** key allows you to go back to the list of drives.

Selection of drives for multipoint dialog (select each address and verify the box by pressing **OK**).

All menus can be accessed in multipoint mode. Only drive control via the Graphic Display Terminal is not authorized, apart from the **Stop/Reset** key, which locks all the drives.

If there is a detected error on a drive, this drive is displayed.



---

# Chapter 9

## [File management] F Π Ε -

---

### Introduction



[File management] F Π Ε - menu presents the management of drive configuration files.

### What Is in This Chapter?

This chapter contains the following topics:

Topic	Page
[Transfer config file] Ε Λ F - Menu	724
[Factory settings] F Λ S - Menu	725
[Parameter group list] F ρ Υ - Menu	726
[Factory settings] F Λ S - Menu	727

## [Transfer config file] *⌘ C F* - Menu

### Access

[File management] → [Transfer config file]

### [OPEN] *⌘ P F*

This allows to select a previously saved drive configuration from the Graphic Display Terminal memory and transfer it to the drive.

### [SAVE AS] *⌘ S F F*

This allows to save the actual drive configuration into the Graphic Display Terminal memory.

## [Factory settings] F C 5 - Menu

### Access

[File management] → [Factory settings]

### About This Menu

This parameter allows to select the configuration to restore in case of factory setting operation.

### [Config. Source] F C 5 , ★

Setting	Code / Value	Description
[Macro-Conf]	1 0 1	Factory setting parameter set <b>Factory setting</b>
[Config 1]	C F G 1	Customer parameter set 1
[Config 2]	C F G 2	Customer parameter set 2
[Config 3]	C F G 3	Customer parameter set 3

## [Parameter group list] *F r Y* - Menu

### Access

[File management] → [Factory settings] → [Parameter group list]

### About This Menu

Selection of menus to be loaded.

**NOTE:** In factory configuration and after a return to "factory settings", [Parameter group list] *F r Y* will be empty.

### [All] *ALL*

All parameters in all menus.

### [Drive Configuration] *d r Π*

Load [Complete settings] *CSL* - menu.

### [Motor Param] *Π o t*

Load [Motor parameters] *Π P R* - menu.

### [Comm. Menu] *CSΠ* ★

Load [Communication] *CSΠ* - menu.

This parameter can be accessed if [Config. Source] *FLS* is set to [Macro-Conf] *in*.

### [Display Config.] *d , 5* ★

Load [Display screen type] *Π 5 C* - menu.

This parameter can be accessed if [Config. Source] *FLS* is set to [Macro-Conf] *in*.

**[Factory settings] F C 5 - Menu****Access**

[File management] → [Factory settings]

**[Go to Factory settings] G F 5****⚠ WARNING****UNANTICIPATED EQUIPMENT OPERATION**

Verify that restoring the factory settings is compatible with the type of wiring used.

**Failure to follow these instructions can result in death, serious injury, or equipment damage.**

It is only possible to revert to the factory settings if at least one group of parameters has previously been selected.

**[Save Configuration] S C 5 , ★**

Save configuration.

The active configuration to be saved does not appear for selection. For example, if it is **[Config 0] S E r 0**, only **[Save Config 1] S E r 1** and **[Config 2] S E r 2** appear. The parameter changes back to **[No] n o** as soon as the operation is complete.

Setting	Code / Value	Description
<b>[No]</b>	<i>n o</i>	No <b>Factory setting</b>
<b>[Config 0]</b>	<i>S E r 0</i>	Store customer parameter set 0
<b>[Save Config 1]</b>	<i>S E r 1</i>	Store customer parameter set 1
<b>[Config 2]</b>	<i>S E r 2</i>	Store customer parameter set 2
<b>[Config 3]</b>	<i>S E r 3</i>	Store customer parameter set 3





---

# Chapter 10

## [My preferences] ПУР -

---

### Introduction



[My preferences] ПУР - menu presents the possible settings for the user-defined HMI and parameter access.

### What Is in This Chapter?

This chapter contains the following sections:

Section	Topic	Page
10.1	[Language]	730
10.2	[Password]	731
10.3	[Parameter access]	732
10.4	[Customization]	736
10.5	[Date & Time settings]	742
10.6	[Access level]	743
10.7	[Webserver]	744
10.8	[Functions key mgnt]	745
10.9	[LCD settings]	746
10.10	[Stop and go]	747
10.11	[QR code]	748
10.12	[QR code] - [My link 1]	749
10.13	[QR code] - [My link 2]	750
10.14	[QR code] - [My link 3]	751
10.15	[QR code] - [My link 4]	752
10.16	[Pairing password]	753

## Section 10.1

### [Language]

---

#### [Language] L n G - Menu

##### Access

[My preferences] → [Language]

##### About This Menu

This menu allows to select the Graphic Display Terminal language.

## Section 10.2

### [Password]

#### [Password] $\text{C o d} - \text{Menu}$

##### Access

[My preferences] → [Password]

##### About This Menu

Enables the configuration to be protected with an access code or a password to be entered in order to access a protected configuration:

- The drive is unlocked when the password is set to **[No password defined]**  $n o$  or when the correct password has been entered. All menus can be accessed.
- Before protecting the configuration with a password, you must:
  - Define the **[Upload rights]**  $u L r$  and **[Download rights]**  $d L r$ .
  - Make a careful note of the password and keep it in a place where you are able to find it.

#### [Password status] $P S S t$

Password status.

Setting	Code / Value	Description
<b>[No password defined]</b>	$n o$	No password defined <b>Factory setting</b>
<b>[Password is unlocked]</b>	$u L$	Password is unlocked
<b>[Password is locked]</b>	$L o C$	Password is locked

#### [Password] $P W d$

6-digits password. The password must be entered in order to unlock the drive. Once the correct code has been entered, the drive is unlocked until the next time the supply mains is disconnected.

#### [Upload rights] $u L r$

Upload rights.

Setting 	Code / Value	Description
<b>[Permitted]</b>	$u L r 0$	Commissioning tools or the Graphic Display Terminal can save the whole configuration (password, monitoring, configuration) <b>Factory setting</b>
<b>[Not allowed]</b>	$u L r 1$	Commissioning tools or the Graphic Display Terminal cannot save the configuration

#### [Download rights] $d L r$

Download rights.

Setting 	Code / Value	Description
<b>[Locked drv]</b>	$d L r 0$	Lock drive: the configuration can be downloaded only in a locked drive which configuration has the same password
<b>[Unlock. drv]</b>	$d L r 1$	Unlock drive: the configuration can be downloaded only in a drive without active password <b>Factory setting</b>
<b>[Not allowed]</b>	$d L r 2$	The configuration can never be downloaded
<b>[Lock/unlock]</b>	$d L r 3$	Download is permitted according to case 0 or case 1

## Section 10.3

### [Parameter access]

---

#### What Is in This Section?

This section contains the following topics:

Topic	Page
[Restricted channels] <i>P C d</i> - Menu	733
[Restricted param] <i>P P R</i> - Menu	734
[Visibility] <i>V , S</i> - Menu	735

---

## [Restricted channels] *P C d* - Menu

### Access

[My preferences] → [Parameter access] → [Restricted access] → [Restricted channels]

### About This Menu

Following channels can be selected to disable the accessibility to the related parameters.

#### [HMI] *C o n*

Graphic Display Terminal.

#### [PC Tool] *P w S*

DTM-based commissioning software.

#### [Modbus] *M d b*

Embedded Modbus serial.

#### [CANopen] *C A n*

CANopen fieldbus module.

#### [Com. Module] *n E t*

Fieldbus option module.

## [Restricted param] P P R - Menu

### Access

[My preferences] → [Parameter access] → [Restricted access] → [Restricted param]

### About This Menu

In these screens, all parameters in the **[Complete settings] L 5 L** - menu can be protected and are displayed for selection, except for the Expert parameters.

Press the **All** key to select all the parameters. Press the **All** key again to deselect all the parameters.

Content of the **[Complete settings] L 5 L** - menu. No selections can be made in this screen if there are no parameters.

**[Visibility] V , 5 - Menu****Access**

[My preferences] → [Parameter access] → [Visibility]

**About This Menu**

Selection to display all parameters or only the active parameters.

**[Parameters] P V , 5**

Parameters.

Setting( )	Code / Value	Description
[Active]	<i>A C E</i>	Only active parameters can be accessed <b>Factory setting</b>
[All]	<i>A L L</i>	All parameters can be accessed

## Section 10.4 [Customization]

---

### What Is in This Section?

This section contains the following topics:

Topic	Page
[My menu config.] <i>MYC</i> - Menu	737
[Display screen type] <i>DSL</i> - Menu	738
[Param. Bar Select] <i>PBS</i> - Menu	739
[Customer parameters] <i>CYP</i> - Menu	740
[Service message] <i>SER</i> - Menu	741



---

## [My menu config.] ПУС - Menu

### Access

[My preferences] → [Customization] → [My menu config.]

### About This Menu

This menu allows to customize the [My Menu] ПУПН - menu (*see page 50*).

### [Parameter Selection] ППР

Content of the [Complete settings] ССЛ - menu.

No selection can be made in this screen if there are no parameters.

### [Selected List] ППЛ

This menu allows to sort the selected parameters.

### [My Menu] ПУПН

Used to define the name of the customized menu.

**[Display screen type] П 5 C - Menu****Access**

[My preferences] → [Customization] → [Display screen type]

**About This Menu**

This parameter allows to select the type of display for the default screen.

**[Display value type] П д E**

Type of screen display.

Setting ( )	Code / Value	Description
[Digital]	<i>d E C</i>	Digital values <b>Factory setting</b>
[Bar graph]	<i>b A r</i>	Bar graph
[List]	<i>L i S t</i>	List of values
[Vu Meter]	<i>V u M E t</i>	Vu meter

**[Parameter Selection] П P C**

Customized selection.

This view allows to select the parameters to display on the default screen.

## **[Param. Bar Select] P b 5 - Menu**

### **Access**

**[My preferences] → [Customization] → [Param. Bar Select]**

### **About This Menu**

This view allows to select the parameters to display on the top line of the Graphic Display Terminal screen.

## [Customer parameters] *CP* - Menu

### Access

[My preferences] → [Customization] → [Customer parameters]

### About This Menu

This menu allows to rename up to 15 parameters.

### [Parameter Selection] *SCP*

Parameter selection.

This view allows to select up to 15 parameters.

### [Custom Selection] *CPN*

Customized selection.

This view allows to set for each selected parameter:

- The name
- The unit if relevant (a custom unit is available)
- A multiplier (1...1000) if relevant
- A divisor (1...1000) if relevant
- An offset (-99.00...99.00) if relevant

## [Service message] 5 E r - Menu

### Access

[My preferences] → [Customization] → [Service message]

### About This Menu

This menu allows to define a user-defined service message (5 lines, 23 digits per line).

This message can be displayed in [theDiagnostics] *d i R* -, [Diag. data] *d d E* - menu and [Service message] 5 E r - submenus.

#### [LINE 1] 5 N L 0 1

Line 1.

#### [LINE 2] 5 N L 0 2

Line 2.

#### [LINE 3] 5 N L 0 3

Line 3.

#### [LINE 4] 5 N L 0 4

Line 4.

#### [LINE 5] 5 N L 0 5

Line 5.

## Section 10.5

### [Date & Time settings]

---

#### [Date/time settings] - Menu

##### Access

[My preferences] → [Date/time settings]

##### About This Menu

This view allows to set date and time. This information is used for the time stamping of all logged data.

If a time server is connected over Ethernet and configured in the webserver, date and time data are updated automatically according to the configuration.

Date and time information shall be available (time server available and configured, or Graphic Display Terminal plugged) at drive power up to enable the time stamping of the logged data.

Modifying these settings will modify previously logged data value in case of average data based on time.

## Section 10.6

### [Access level]

#### [Access level] L A C - Menu

##### Access

[My preferences] → [Access level]

##### About This Menu

### WARNING

#### UNINTENDED EQUIPMENT OPERATION

A single input can activate several functions at the same time (reverse and 2nd ramp for example).  
Verify that activating a digital input to several functions does not result in unsafe conditions.

**Failure to follow these instructions can result in death, serious injury, or equipment damage.**

#### [Access Level] L A C

Level of access control.

Setting ( )	Code / Value	Description
[Basic]	b A S	Access to the [Simply start] S Y S - , [Dashboard] d S H - , [Diagnostics] d , R - and [My preferences] M Y P - menus only.
[Standard]	S t d	Access to all menus. <b>Factory setting</b>
[Expert]	E P r	Access to all menus and to additional parameters.

## Section 10.7

### [Webserver]

#### [Webserver] *W b S* - Menu

##### Access

[My preferences] → [Webserver]

##### About This Menu

This menu allows to manage Web services.

#### [EnableWebserver] *E W E E*

Enable Web services for the embedded Ethernet Modbus TCP adapter.

Setting	Code / Value	Description
[No]	<i>n o</i>	Webserver disabled
[Yes]	<i>Y E S</i>	Webserver enabled <b>Factory setting</b>

#### [EnableWebserver] *E W E* ★

Enable Web services for the Ethernet based modules.

This parameter can be accessed if Ethernet-IP Modbus TCP or PROFINET fieldbus module has been inserted.

Setting	Code / Value	Description
[No]	<i>n o</i>	Webserver disabled
[Yes]	<i>Y E S</i>	Webserver enabled <b>Factory setting</b>

#### [Reset EmbWeb] *r W P E*

Reset the embedded Ethernet Modbus TCP webserver to its default configuration.

The default password is ADMIN.

Setting ( )	Code / Value	Description
[No]	<i>n o</i>	No <b>Factory setting</b>
[Yes]	<i>Y E S</i>	Yes

#### [Reset OptWeb Passwd] *r W P o* ★

Reset the password of the Ethernet-IP Modbus TCP fieldbus module webserver.

This parameter can be accessed if Ethernet-IP Modbus TCP fieldbus module has been inserted.

Setting ( )	Code / Value	Description
[No]	<i>n o</i>	No <b>Factory setting</b>
[Yes]	<i>Y E S</i>	Yes



## Section 10.8

### [Functions key mgnt]

#### [Functions key mgnt] *F K G* - Menu

##### Access

[My preferences] → [Functions key mgnt]

##### About This Menu

This menu allows to assign functions to the Graphic Display Terminal function keys.

##### [F1 key assignment] *F n 1*

Function key 1. Following possible assignments cannot be accessed in **[I/O profile]** *i o* configuration.

Setting	Code / Value	Description
[No]	<i>n o</i>	Not assigned <b>Factory setting</b>
[Preset Speed 1]	<i>F P S 1</i>	Function key preset speed 1 assignment
[Preset Speed 2]	<i>F P S 2</i>	Function key preset speed 2 assignment
[PID Ref Frequency 1]	<i>F P r 1</i>	Function key preset PID 1 assignment
[PID Ref Frequency 2]	<i>F P r 2</i>	Function key preset PID 2 assignment
[+Speed]	<i>F u S P</i>	Function key faster assignment
[-Speed]	<i>F d S P</i>	Function key slower assignment

##### [F2 key assignment] *F n 2*

Function key 2.

Identical to **[F1 key assignment]** *F n 1*.

##### [F3 key assignment] *F n 3*

Function key 3.

Identical to **[F1 key assignment]** *F n 1*.

##### [F4 key assignment] *F n 4*

Function key 4.

Identical to **[F1 key assignment]** *F n 1*.

## Section 10.9

### [LCD settings]

#### [LCD settings] *Ⓛ Ⓝ Ⓛ* - Menu

##### Access

[My preferences] → [LCD settings]

##### About This Menu

This menu allows to set the Graphic Display Terminal related parameters.

#### [Screen Contrast] *Ⓛ 5 Ⓛ*

Screen contrast setting.

Setting	Description
0...100%	Setting range <b>Factory setting:</b> 50%

#### [Standby] *5 Ⓟ 5*

Stand-by delay.

**NOTE:** Disabling the automatic standby function of the display terminal backlight will reduce the backlight service time.

Setting	Description
<i>Ⓝ Ⓟ</i> ...10 min	Automatic backlight OFF time <b>Factory setting:</b> 10 min

#### [Display Terminal locked] *Ⓚ Ⓛ Ⓛ Ⓚ*

Graphic Display Terminal key locked. Press **ESC** and **Home** keys to Lock manually & unlock the Graphic Display Terminal keys. The **Stop** key remains active when the Graphic Display Terminal is locked.

Setting <i>( )</i>	Description
<i>Ⓝ Ⓟ</i> ...10 min	Setting range <b>Factory setting:</b> 5 min

#### [Red Backlight] *Ⓟ Ⓛ Ⓚ Ⓛ ★*

Graphic Display Terminal red backlight function disabled in case or an error triggered.

Setting <i>( )</i>	Code / Value	Description
[No]	<i>Ⓝ Ⓟ</i>	Red backlight disabled
[Yes]	<i>5 Ⓛ 5</i>	Red backlight enabled <b>Factory setting</b>

## Section 10.10

### [Stop and go]

#### [Stop and go] *S E G* - Menu

##### Access

[My preferences] → [Stop and go]

##### About This Menu

This function is available for drives from frame size 4 to 7. When the function is active, the DC bus voltage is no longer maintained at operational level in order to save energy. When the drive is in energy saving state, the next run command shall be delayed up to 1 second during the DC bus charge.

#### [Energy Saving Delay] *, d L 7*

Wait time before going to energy saving (ESAV) mode after motor is stopped.

The value **[No]** *n o* deactivate the function.

Setting	Description
<b>[No]</b> <i>n o</i> ...32,400 s	Setting range Factory setting: <i>n o</i>

#### [Energy Saving Assign] *, d L 5*

Energy saving mode digital input assignment.

At active state rising edge, the drive switches to energy saving state if the motor is stopped without a run command active. A falling edge switch the drive to normal operation.

Setting	Code / Value	Description
<b>[Not Assigned]</b>	<i>n o</i>	Not assigned Factory setting
<b>[DI1]...[DI6]</b>	<i>L , l ... L , l 6</i>	Digital input DI1...DI6
<b>[DI11]...[DI16]</b>	<i>L , l l ... L , l 16</i>	Digital input DI11...DI16 if VW3A3203 I/O extension module has been inserted
<b>[CD00]...[CD10]</b>	<i>C d 0 0 ... C d 1 0</i>	Virtual digital input CMD.0...CMD.10 in <b>[I/O profile]</b> <i>, o</i> configuration
<b>[CD11]...[CD15]</b>	<i>C d 1 1 ... C d 1 5</i>	Virtual digital input CMD.11...CMD.15 regardless of configuration
<b>[C100]...[C110]</b>	<i>C 1 0 0 ... C 1 1 0</i>	Virtual digital input CMD1.0...CMD1.10 with integrated Modbus Serial in <b>[I/O profile]</b> <i>, o</i> configuration
<b>[C111]...[C115]</b>	<i>C 1 1 1 ... C 1 1 5</i>	Virtual digital input CMD1.11...CMD1.15 with integrated Modbus Serial regardless of configuration
<b>[C200]...[C210]</b>	<i>C 2 0 0 ... C 2 1 0</i>	Virtual digital input CMD2.0...CMD2.10 with CANopen® fieldbus module in <b>[I/O profile]</b> <i>, o</i> configuration
<b>[C211]...[C215]</b>	<i>C 2 1 1 ... C 2 1 5</i>	Virtual digital input CMD2.11...CMD2.15 with CANopen® fieldbus module regardless of configuration
<b>[C300]...[C310]</b>	<i>C 3 0 0 ... C 3 1 0</i>	Virtual digital input CMD3.0...CMD3.10 with a fieldbus module in <b>[I/O profile]</b> <i>, o</i> configuration
<b>[C311]...[C315]</b>	<i>C 3 1 1 ... C 3 1 5</i>	Virtual digital input CMD3.11...CMD3.15 with a fieldbus module regardless of configuration
<b>[C500]...[C510]</b>	<i>C 5 0 0 ... C 5 1 0</i>	Virtual digital input CMD5.0...CMD5.10 with integrated Ethernet Modbus TCP in <b>[I/O profile]</b> <i>, o</i> configuration
<b>[C511]...[C515]</b>	<i>C 5 1 1 ... C 5 1 5</i>	Virtual digital input CMD5.11...CMD5.15 with integrated Ethernet Modbus TCP regardless of configuration

## Section 10.11

### [QR code]

---

#### [QR code] 9 r C - Menu

##### Access

[My preferences] → [QR code]

##### About This Menu

This menu gives access to a QR Codes on the Graphic Display Terminal.

##### [QR Code] 9 C C

Scan of this QR code brings to a landing page on Internet with the information on:

- Technical product datasheet,
- Link for Schneider Electric App available for services.

## Section 10.12

### [QR code] - [My link 1]

---

#### [My link 1] 79 L 1 - Menu

##### Access

[My preferences] → [QR code] → [My link 1]

##### About This Menu

This menu gives access to a QR Code customized with the commissioning software.

#### [MyLink 1] 9 L 1

## Section 10.13

### [QR code] - [My link 2]

---

#### [My link 2] 14 L 2 - Menu

##### Access

[My preferences] → [QR code] → [My link 2]

##### About This Menu

This menu gives access to a QR Code customized with the commissioning software.

#### [MyLink 2] 9 L 2

## Section 10.14

### [QR code] - [My link 3]

---

#### [My link 3] 7 9 L 3 - Menu

##### Access

[My preferences] → [QR code] → [My link 3]

##### About This Menu

This menu gives access to a QR Code customized with the commissioning software.

#### [MyLink 3] 9 L 3

## Section 10.15

### [QR code] - [My link 4]

---

#### [My link 4] ПУЛ 4 - Menu

##### Access

[My preferences] → [QR code] → [My link 4]

##### About This Menu

This menu gives access to a QR Code customized with the commissioning software.

#### [MyLink 4] 9L 4



## Section 10.16

### [Pairing password]

#### [Pairing password] P P ,

##### Access

[My preferences] → [Pairing password]

##### About This Menu

This function can only be accessed in Expert mode. This function is used to detect whenever an option module has been replaced or the software has been modified in any way. When a pairing password is entered, the parameters of the option modules currently inserted are stored. On every subsequent power-up, these parameters are verified and, in the event of a discrepancy, the drive locks in **[Boards Compatibility] H C F**. Before the drive can be restarted, it is necessary to revert to the original situation or reenter the pairing password.

The following parameters are verified:

- The type of option modules.
- The software version of the drive and the option modules.
- The serial number for the control block boards.

#### [Pairing password] P P ,

Operation as a pair password.

Setting	Description
[OFF] 0 F F ...9,999	Setting range Factory setting: 0 F F

The **[OFF] 0 F F** value signifies that the pairing password function is inactive.

The **[ON] 0 n** value signifies that the pairing password function is active and that a password is required to start the drive in the event of a **[Boards Compatibility] H C F** detected error.

As soon as the password has been entered, the drive is unlocked and the code changes to **[ON] 0 n**.



---

## Part III

### Maintenance and diagnostics

---

#### What Is in This Part?

This part contains the following chapters:

Chapter	Chapter Name	Page
11	Maintenance	757
12	Diagnostics and Troubleshooting	759



# Chapter 11

## Maintenance

### Maintenance

#### Limitation of Warranty

The warranty does not apply if the product has been opened, except by Schneider Electric services.

#### Servicing

 <b>DANGER</b>
<p><b>HAZARD OF ELECTRIC SHOCK, EXPLOSION OR ARC FLASH</b></p> <p>Read and understand the instructions in <b>Safety Information</b> chapter before performing any procedure in this chapter.</p> <p><b>Failure to follow these instructions will result in death or serious injury.</b></p>

<b>NOTICE</b>
<p><b>RISK OF DAMAGE TO THE DRIVE</b></p> <p>Perform the following activities.</p> <p><b>Failure to follow these instructions can result in equipment damage.</b></p>

Environment	Part concerned	Action	Periodicity
Mechanical impact on the product	Housing - control block (led - display)	Verify the drive visual aspect	At least each year
Corrosion	Terminals - connector - screws - EMC plate	Inspect and clean if required	
Dust	Terminals - fans blowholes		
Temperature	Around the product	Verify and correct if required	
Cooling	Fan	Verify the fan operation	After 3 to 5 years, depending on the operating conditions
		Replace the fan	
Vibration	Terminal connections	Verify tightening at recommended torque	At least each year

#### Spares and Repairs

Serviceable product. Please contact your Schneider Electric representative.

## Long Time Storage

### CAUTION

#### **RISK OF DERATED PERFORMANCE DUE TO CAPACITOR AGING**

The product capacitor performances after a long time storage above 2 years can be degraded. In that case, before using the product, apply the following procedure:

- Use a variable AC supply connected between L1 and L2
- Increase AC supply voltage to have:
  - 80% of rated voltage during 30 min
  - 100% of rated voltage for another 30 min

**Failure to follow these instructions can result in injury or equipment damage.**

## Fan Replacement

It is possible to order a new fan for the drive maintenance, see the catalog numbers on [www.schneider-electric.com](http://www.schneider-electric.com).

---

# Chapter 12

## Diagnostics and Troubleshooting

---

### Overview

This chapter describes the various types of diagnostics and provides troubleshooting assistance.

### DANGER

#### HAZARD OF ELECTRIC SHOCK, EXPLOSION OR ARC FLASH

Read and understand the instructions in **Safety Information** chapter before performing any procedure in this chapter.

**Failure to follow these instructions will result in death or serious injury.**

### What Is in This Chapter?

This chapter contains the following sections:

Section	Topic	Page
12.1	Warning Codes	760
12.2	Error Codes	762
12.3	FAQ	854

## Section 12.1

### Warning Codes

#### Warning Codes

##### List of Available Warnings

Setting	Code / Value	Description
[AI1 4-20 Loss Warning]	<i>RP 1</i>	4-20 loss warning on analog input AI1
[AI2 4-20 Loss Warning]	<i>RP 2</i>	4-20 loss warning on analog input AI2
[AI3 4-20 Loss Warning]	<i>RP 3</i>	4-20 loss warning on analog input AI3
[AI4 4-20 Loss Warning]	<i>RP 4</i>	4-20 loss warning on analog input AI4
[AI5 4-20 Loss Warning]	<i>RP 5</i>	4-20 loss warning on analog input AI5
[Cust Warning 1]	<i>CRS 1</i>	Customer warning 1
[Cust Warning 2]	<i>CRS 2</i>	Customer warning 2
[Cust Warning 3]	<i>CRS 3</i>	Customer warning 3
[Cust Warning 4]	<i>CRS 4</i>	Customer warning 4
[Cust Warning 5]	<i>CRS 5</i>	Customer warning 5
[Current Thd Reached]	<i>CLR</i>	Motor current high threshold reached
[Low Current Reached]	<i>CLRL</i>	Motor current low threshold reached
[Dry Run Warning]	<i>DRRY</i>	Dry run monitoring function warning
[Ext. Error Warning]	<i>EFA</i>	External error warning
[2nd Frequency Thd Reached]	<i>F2R</i>	Second frequency threshold reached
[Motor Freq Low Thd 2]	<i>F2RL</i>	Motor frequency low threshold 2 reached
[Fan Counter Warning]	<i>FCLR</i>	Fan counter warning
[Fan Feedback Warning]	<i>FFdR</i>	Fan feedback warning
[High Speed Reached]	<i>FLR</i>	High speed reached
[Fallback Frequency]	<i>Frf</i>	Fallback frequency reaction
[Flow Limit Activated]	<i>FSR</i>	Flow limitation monitoring function is active
[Motor Freq High Thd]	<i>FLR</i>	Motor frequency high threshold reached
[Motor Freq Low Thd]	<i>FLRL</i>	Motor frequency low threshold reached
[High Flow Warning]	<i>HFPF</i>	High flow monitoring function warning
[InPres Warning]	<i>IPPR</i>	Inlet pressure monitoring function warning level reached
[Anti-Jam Warning]	<i>JARN</i>	Anti-Jam maximum cycle counter reached
[Life Cycle Warn 1]	<i>LCR 1</i>	Life cycle warning 1
[Life Cycle Warn 2]	<i>LCR 2</i>	Life cycle warning 2
[Low Flow Warning]	<i>LFR</i>	Low flow monitoring function warning level reached
[LowPres Warning]	<i>LPR</i>	Low pressure monitoring function warning level reached
[No Warning stored]	<i>noR</i>	No warning stored
[Process Overload Warning]	<i>oLR</i>	Process overload warning
[High OutPres Warning]	<i>oPHR</i>	High outlet pressure warning
[Low OutPres Warning]	<i>oPLR</i>	Low outlet pressure warning
[Switch OutPres Warning]	<i>oPSR</i>	High outlet pressure switch warning
[PumpCycle warning]	<i>PCPR</i>	Pumpcycle warning
[PID Error Warning]	<i>PEE</i>	PID error warning
[PID Feedback Warning]	<i>PFR</i>	PID feedback warning
[PID High Fdbck Warning]	<i>PFRH</i>	PID feedback high threshold warning
[PID Low Fdbck Warning]	<i>PFRl</i>	PID feedback low threshold warning
[Regulation Warning]	<i>PiSH</i>	PID feedback regulation warning



Setting	Code / Value	Description
[Pump Low Flow]	<i>P L F R</i>	Pump low flow warning level reached
[Power Cons Warning]	<i>P o W d</i>	Power consumption warning
[Power High Threshold]	<i>P t H R</i>	Power high threshold reached
[Power Low Threshold]	<i>P t H L</i>	Power low threshold reached
[Speed Maintained]	<i>r L S</i>	Speed maintained function is active
[Ref Freq High Thd reached]	<i>r t R H</i>	Reference frequency high threshold reached
[Ref Freq Low Thd reached]	<i>r t R L</i>	Reference frequency low threshold reached
[Ref Frequency Warning]	<i>S r R</i>	Reference frequency reached
[Type of stop]	<i>S t t</i>	Detected error without stop according to [Type of stop] <i>S t t</i>
[Drv Therm Thd Reached]	<i>t R d</i>	Drive thermal threshold reached
[Drive Thermal Warning]	<i>t H R</i>	Drive thermal state warning
[IGBT Thermal Warning]	<i>t J R</i>	IGBT thermal state warning
[AI2 Th Warning]	<i>t P 2 R</i>	Thermal sensor warning on analog input AI2
[AI3 Th Warning]	<i>t P 3 R</i>	Thermal sensor warning on analog input AI3
[AI4 Th Warning]	<i>t P 4 R</i>	Thermal sensor warning on analog input AI4
[AI5 Th Warning]	<i>t P 5 R</i>	Thermal sensor warning on analog input AI5
[Motor Therm Thd Reached]	<i>t S R</i>	Motor thermal threshold reached
[Process Undld Warning]	<i>u L R</i>	Process underload warning
[Preventive UnderV Active]	<i>u P R</i>	Preventive undervoltage active
[Undervoltage Warning]	<i>u S R</i>	Undervoltage warning
[Ethernet Internal Warning]	<i>i n W n</i>	Ethernet internal warning

## Section 12.2

### Error Codes

#### What Is in This Section?

This section contains the following topics:

Topic	Page
Overview	764
[Angle error] <i>R 5 F</i>	765
[Incorrect Configuration] <i>C F F</i>	766
[Invalid Configuration] <i>C F 1</i>	767
[Conf Transfer Error] <i>C F 1 2</i>	768
[Fieldbus Com Interrupt] <i>C n F</i>	769
[CANopen Com Interrupt] <i>C o F</i>	770
[Precharge Capacitor] <i>C r F</i>	771
[Channel Switch Error] <i>C S F</i>	772
[Dry Run Error] <i>d r Y F</i>	773
[EEPROM Control] <i>E E F 1</i>	774
[EEPROM Power] <i>E E F 2</i>	775
[External Error] <i>E P F 1</i>	776
[Fieldbus Error] <i>E P F 2</i>	777
[Embd Eth Com Interrupt] <i>E t H F</i>	778
[Boards Compatibility] <i>H C F</i>	779
[High Flow Error] <i>H F P F</i>	780
[Internal Link Error] <i>i L F</i>	781
[Internal Error 0] <i>i n F 0</i>	782
[Internal Error 1] <i>i n F 1</i>	783
[Internal Error 2] <i>i n F 2</i>	784
[Internal Error 3] <i>i n F 3</i>	785
[Internal Error 4] <i>i n F 4</i>	786
[Internal Error 6] <i>i n F 6</i>	787
[Internal Error 7] <i>i n F 7</i>	788
[Internal Error 8] <i>i n F 8</i>	789
[Internal Error 9] <i>i n F 9</i>	790
[Internal Error 10] <i>i n F A</i>	791
[Internal Error 11] <i>i n F b</i>	792
[Internal Error 12] <i>i n F C</i>	793
[Internal Error 13] <i>i n F d</i>	794
[Internal Error 14] <i>i n F E</i>	795
[Internal Error 15] <i>i n F F</i>	796
[Internal Error 16] <i>i n F G</i>	797
[Internal Error 17] <i>i n F h</i>	798
[Internal Error 18] <i>i n F i</i>	799
[Internal Error 20] <i>i n F K</i>	800
[Internal Error 21] <i>i n F L</i>	801
[Internal Error 25] <i>i n F P</i>	802
[Internal Error 27] <i>i n F r</i>	803
[Internal Error 30] <i>i n F W</i>	804
[Inlet Pressure Error] <i>i P P F</i>	805
[Anti Jam Error] <i>J A n F</i>	806

Topic	Page
[Input Contactor] <i>L C F</i>	807
[High Level Error] <i>L C H F</i>	808
[High Level Error] <i>L C L F</i>	809
[AI1 4-20mA loss] <i>L F F 1</i>	810
[AI2 4-20mA loss] <i>L F F 2</i>	811
[AI3 4-20mA loss] <i>L F F 3</i>	812
[AI4 4-20mA loss] <i>L F F 4</i>	813
[AI5 4-20mA loss] <i>L F F 5</i>	814
[Lead Pump Error] <i>Π P L F</i>	815
[DC Bus Overvoltage] <i>α b F</i>	816
[Overcurrent] <i>α C F</i>	817
[Drive Overheating] <i>α H F</i>	818
[Process Overload] <i>α L C</i>	819
[Motor Overload] <i>α L F</i>	820
[Single Output Phase Loss] <i>α P F 1</i>	821
[Output Phase Loss] <i>α P F 2</i>	822
[Out Pressure High] <i>α P H F</i>	823
[Out Pressure Low] <i>α P L F</i>	824
[Supply Mains Overvoltage] <i>α S F</i>	825
[PumpCycle Start Error] <i>P C P F</i>	826
[PID Feedback Error] <i>P F Π F</i>	827
[Program Loading Error] <i>P G L F</i>	828
[Program Running Error] <i>P G r F</i>	829
[Input phase loss] <i>P H F</i>	830
[Pump Low Flow Error] <i>P L F F</i>	831
[Safety Function Error] <i>S R F F</i>	832
[Motor short circuit] <i>S C F 1</i>	833
[Ground Short Circuit] <i>S C F 3</i>	834
[IGBT Short Circuit] <i>S C F 4</i>	835
[Motor Short Circuit] <i>S C F 5</i>	836
[Modbus Com Interruption] <i>S L F 1</i>	837
[PC Com Interruption] <i>S L F 2</i>	838
[HMI Com Interruption] <i>S L F 3</i>	839
[Motor Overspeed] <i>S α F</i>	840
[Motor Stall Error] <i>S ε F</i>	841
[AI2 Thermal Sensor Error] <i>ε 2 C F</i>	842
[AI3 Thermal Sensor Error] <i>ε 3 C F</i>	843
[AI4 Thermal Sensor Error] <i>ε 4 C F</i>	844
[AI5 Thermal Sensor Error] <i>ε 5 C F</i>	845
[AI2 Th Error Level] <i>ε H 2 F</i>	846
[AI3 Th Error Level] <i>ε H 3 F</i>	847
[AI4 Th Error Level] <i>ε H 4 F</i>	848
[AI5 Th Error Level] <i>ε H 5 F</i>	849
[IGBT Overheating] <i>ε J F</i>	850
[Autotuning Error] <i>ε n F</i>	851
[Process Underload] <i>υ L F</i>	852
[Supply Mains UnderV] <i>υ S F</i>	853

## Overview

### Clearing the Detected Error

This table presents the steps to follow if intervention on the drive system is required:

Step	Action
1	Disconnect all power, including external control power that may be present.
2	Lock that all power disconnects in the open position.
3	Wait 15 minutes to allow the DC bus capacitors to discharge (the drive LEDs are not indicators of the absence of DC bus voltage).
4	Measure the voltage of the DC bus between the PA/+ and PC/- terminals to ensure that the voltage is less than 42 Vdc.
5	If the DC bus capacitors do not discharge completely, contact your local Schneider Electric representative. Do not repair or operate the drive.
6	Find and correct the cause of the detected error.
7	Restore power to the drive to confirm that the detected error has been rectified.

After the cause has been removed, the detected error can be cleared by:

- Switching off the drive.
- Using the **[Product Restart]**  $r P$  parameter.
- Using the **[Auto Fault Reset]**  $f E r$  - function.
- A digital input or control bit set to the **[Fault reset]**  $r 5 E$  - function.
- Pressing the **STOP/RESET** key on the Graphic Display Terminal if the active command channel is set to **[Ref. Freq-Rmt.Term]**  $L C C$ .

**[Angle error] *r 5 F*****Probable Cause**

For the motor control type **[Sync. mot.] *5 Y n u***, wrong setting of the speed loop when the reference goes through 0.

**Remedy**

- Verify the speed loop parameters.
- Verify the motor phases and the maximum current allowed by the drive.

**Clearing the Error Code**

This detected error can be cleared manually with the **[Fault Reset Assign] *r 5 F*** parameter after the cause has disappeared.

## [Incorrect Configuration] *L F F*



### Probable Cause

- Option module changed or removed.
- Control block replaced by a control block configured on a drive with a different rating.
- The current configuration is inconsistent.



### Remedy

- Verify that there is no detected error on the option module.
- In the event of the control block being changed deliberately, see the remarks below.
- Return to factory settings or retrieve the backup configuration if it is valid.



### Clearing the Error Code

This detected error is cleared as soon as its cause disappears.

**[Invalid Configuration] [ F ]****Probable Cause**

Invalid configuration. The configuration loaded in the drive via the commissioning tool or fieldbus is inconsistent.

**Remedy**

- Verify the previously loaded configuration.
- Load a compatible configuration.

**Clearing the Error Code**

This detected error is cleared as soon as its cause disappears.

## [Conf Transfer Error] [ F 12 ]



### Probable Cause

- The configuration has not been transferred properly.
- The configuration loaded is not compatible with the drive.



### Remedy

- Check the configuration loaded previously.
- Load a compatible configuration.



### Clearing the Error Code

This detected error is cleared as soon as its cause disappears.



**[Fieldbus Com Interrupt]  $E n F$** **Probable Cause**

Communication interruption on fieldbus module.

**Remedy**

- Verify the environment (electromagnetic compatibility).
- Verify the wiring.
- Verify the timeout.
- Replace the option module.
- Contact your local Schneider Electric representative

**Clearing the Error Code**

This detected error can be cleared with the **[Auto Fault Reset]  $H E r$**  or manually with the **[Fault Reset Assign]  $r 5 F$**  parameter after the cause has disappeared.

## [CANopen Com Interrupt] *C 0 F*



### Probable Cause

Communication interruption on the CANopen® fieldbus



### Remedy

- Verify the communication fieldbus.
- Verify the timeout.
- Refer to the CANopen® user manual.



### Clearing the Error Code

This detected error can be cleared with the **[Auto Fault Reset] *AE r*** or manually with the **[Fault Reset Assign] *r 5 F*** parameter after the cause has disappeared.

**[Precharge Capacitor]  $C_r F$** **Probable Cause**

Charging circuit control detected error or charging resistor damaged.

**Remedy**

- Turn off the drive and then turn on again.
- Verify the internal connections.
- Contact your local Schneider Electric representative

**Clearing the Error Code**

This detected error requires a power reset.

## [Channel Switch Error] *L 5 F*



### Probable Cause

Switch to a not valid channel.



### Remedy

Verify the function parameters.



### Clearing the Error Code

This detected error is cleared as soon as its cause disappears.

## [Dry Run Error] *dr 9F*



### Probable Cause

The dry run monitoring function has detected an error.

**NOTE:** After the error has been triggered, even if the detected error has been cleared, it is not possible to restart the pump before the end of the **[DryRun Restart Delay]** *dr 9r*.



### Remedy

- Verify that the pump is well primed.
- Verify that there is no air leak in the suction line.
- Verify the settings of the monitoring function.



### Clearing the Error Code

This detected error can be cleared with the **[Auto Fault Reset]** *fl r* or manually with the **[Fault Reset Assign]** *r 5 F* parameter after the cause has disappeared.

## [EEPROM Control] E E F I



### Probable Cause

An error of the internal memory of the control block has been detected.



### Remedy

- Verify the environment (electromagnetic compatibility).
- Switch off the product.
- Return to factory settings.
- Contact your local Schneider Electric representative.



### Clearing the Error Code

This detected error requires a power reset.

**[EEPROM Power] E E F 2****Probable Cause**

An error of the internal memory of the power board has been detected.

**Remedy**

- Verify the environment (electromagnetic compatibility).
- Switch off the product.
- Return to factory settings.
- Contact your local Schneider Electric representative.

**Clearing the Error Code**

This detected error requires a power reset.

## [External Error] *E P F 1*



### Probable Cause

Event triggered by an external device, depending on user.



### Remedy

Remove the cause of the external error.



### Clearing the Error Code

This detected error can be cleared with the **[Auto Fault Reset] *R E r*** or manually with the **[Fault Reset Assign] *r 5 F*** parameter after the cause has disappeared.



**[Fieldbus Error]  $E P F 2$** **Probable Cause**

An external error has been triggered via fieldbus.

**Remedy**

Remove the cause of the external error.

**Clearing the Error Code**

This detected error can be cleared with the **[Auto Fault Reset]  $A E r$**  or manually with the **[Fault Reset Assign]  $r 5 F$**  parameter after the cause has disappeared.

## [Embd Eth Com Interrupt] *E L H F*



### Probable Cause

Communication interruption on the Ethernet ModbusTCP bus.



### Remedy

- Check the communication bus.
- Refer to the Ethernet user manual.



### Clearing the Error Code

This detected error can be cleared with the **[Auto Fault Reset] *R E r*** or manually with the **[Fault Reset Assign] *r 5 F*** parameter after the cause has disappeared.

**[Boards Compatibility] H C F****Probable Cause**

The **[Pairing password] P P** , parameter has been enabled and an option module has been changed.

**Remedy**

- Refit the original option module.
- Confirm the configuration by entering the **[Pairing password] P P** , if the module was changed deliberately.

**Clearing the Error Code**

This detected error is cleared as soon as its cause disappears.

## [High Flow Error] *H F P F*



### Probable Cause

The high flow monitoring function has detected an error.



### Remedy

- Verify that the system works in its flow capabilities.
- Verify that there is no pipe burst at the outlet of the system.
- Verify the settings of the monitoring function.



### Clearing the Error Code

This detected error can be cleared with the **[Auto Fault Reset]** *A F R* or manually with the **[Fault Reset Assign]** *r 5 F* parameter after the cause has disappeared.

**[Internal Link Error] , L F****Probable Cause**

Communication interruption between option module and the drive.

**Remedy**

- Verify the environment (electromagnetic compatibility).
- Verify the connections.
- Replace the option module.
- Contact your local Schneider Electric representative.

**Clearing the Error Code**

This detected error requires a power reset.

## [Internal Error 0] INF0



### Probable Cause

Communication interruption between microprocessors of the control board.



### Remedy

Contact your local Schneider Electric representative.



### Clearing the Error Code

This detected error requires a power reset.

**[Internal Error 1] INF 1****Probable Cause**

The power board rating is not valid.

**Remedy**

Contact your local Schneider Electric representative.

**Clearing the Error Code**

This detected error requires a power reset.

## [Internal Error 2] INF2



### Probable Cause

The power board is incompatible with the control block software.



### Remedy

Contact your local Schneider Electric representative.



### Clearing the Error Code

This detected error requires a power reset.



**[Internal Error 3] INF3****Probable Cause**

Internal communication detected error.

**Remedy**

- Verify the wiring on drive control terminals (internal 10V supply for analog inputs overloaded).
- Contact your local Schneider Electric representative.

**Clearing the Error Code**

This detected error requires a power reset.

## [Internal Error 4] INF4



### Probable Cause

Internal data inconsistent.



### Remedy

Contact your local Schneider Electric representative.



### Clearing the Error Code

This detected error requires a power reset.

**[Internal Error 6] INF6****Probable Cause**

The option module installed in the drive is not recognized.

**Remedy**

Verify the catalog number and compatibility of the option module.

**Clearing the Error Code**

This detected error requires a power reset.

## [Internal Error 7] INF 7



### Probable Cause

Communication interruption with CPLD component of Control board.



### Remedy

Contact your local Schneider Electric representative.



### Clearing the Error Code

This detected error requires a power reset.

**[Internal Error 8] INF B****Probable Cause**

The internal power switching supply is not correct.

**Remedy**

Contact your local Schneider Electric representative.

**Clearing the Error Code**

This detected error requires a power reset.

## [Internal Error 9] *INF9*



### Probable Cause

An error on the current circuit measurement has been detected.



### Remedy

Contact your local Schneider Electric representative.



### Clearing the Error Code

This detected error can be cleared with the **[Auto Fault Reset] *AR*** or manually with the **[Fault Reset Assign] *r5F*** parameter after the cause has disappeared.

**[Internal Error 10] INF A****Probable Cause**

The input stage is not operating correctly.

**Remedy**

Contact your local Schneider Electric representative.

**Clearing the Error Code**

This detected error requires a power reset.

## [Internal Error 11] *inFb*



### Probable Cause

The internal drive thermal sensor is not operating correctly.



### Remedy

Contact your local Schneider Electric representative.



### Clearing the Error Code

This detected error can be cleared with the **[Auto Fault Reset] *AEr*** or manually with the **[Fault Reset Assign] *r5F*** parameter after the cause has disappeared.



**[Internal Error 12] *INF*****Probable Cause**

Internal current supply error.

**Remedy**

Contact your local Schneider Electric representative.

**Clearing the Error Code**

This detected error requires a power reset.

## [Internal Error 13] *INF d*



### Probable Cause

Differential current deviation.



### Remedy

Contact your local Schneider Electric representative.



### Clearing the Error Code

This detected error requires a power reset.

**[Internal Error 14] INF E****Probable Cause**

Internal microprocessor detected error.

**Remedy**

- Verify that the error code can be cleared.
- Contact your local Schneider Electric representative.

**Clearing the Error Code**

This detected error requires a power reset.

## [Internal Error 15] *INF*



### Probable Cause

Serial memory flash format error.



### Remedy

Contact your local Schneider Electric representative.



### Clearing the Error Code

This detected error requires a power reset.

**[Internal Error 16] INF****Probable Cause**

Communication interruption with the Extension module of output relays module or internal error of the Extension module of output relays

**Remedy**

- Replace the option module.
- Contact your local Schneider Electric representative.

**Clearing the Error Code**

This detected error requires a power reset.

## [Internal Error 17] *INFh*



### Probable Cause

Communication interruption with the Extension module of digital & analog I/O or internal error of the Extension module of digital & analog I/O.



### Remedy

- Replace the option module.
- Contact your local Schneider Electric representative.



### Clearing the Error Code

This detected error requires a power reset.

**[Internal Error 18] INF 1****Probable Cause**

Communication interruption with Safety function module or internal error of the Safety function module.

**Remedy**

- Replace the option module.
- Contact your local Schneider Electric representative.

**Clearing the Error Code**

This detected error requires a power reset.

## [Internal Error 20] *INFK*



### Probable Cause

Option module interface board error.



### Remedy

Contact your local Schneider Electric representative.



### Clearing the Error Code

This detected error requires a power reset.



**[Internal Error 21] *inFL*****Probable Cause**

Internal Real Time Clock error.

**Remedy**

Contact your local Schneider Electric representative.

**Clearing the Error Code**

This detected error requires a power reset.

## [Internal Error 25] *INF P*



### Probable Cause

Incompatibility between Control Board hardware version and firmware version.



### Remedy

- Update the firmware package.
- Contact your local Schneider Electric representative.



### Clearing the Error Code

This detected error requires a power reset.

**[Internal Error 27] *INFR*****Probable Cause**

Diagnostics in CPLD have detected an error.

**Remedy**

Contact your local Schneider Electric representative.

**Clearing the Error Code**

This detected error requires a power reset.

## [Internal Error 30] *in FW*



### Probable Cause

Firmware update function has detected an error.



### Remedy

Contact your local Schneider Electric representative.



### Clearing the Error Code

This detected error requires a power reset.

**[Inlet Pressure Error] , P P F****Probable Cause**

The inlet pressure monitoring function has detected an error.

**Remedy**

- Search for a possible cause of low pressure at the inlet of system.
- Verify the settings of the monitoring function.

**Clearing the Error Code**

This detected error can be cleared with the **[Auto Fault Reset] F E r** or manually with the **[Fault Reset Assign] r 5 F** parameter after the cause has disappeared.

## [Anti Jam Error] *J A N F*



### Probable Cause

The Anti-Jam monitoring function has exceeded the maximum number of sequences allowed in the time window.



### Remedy

- Search for a clogging substance in the impeller.
- Verify the settings of the monitoring function.



### Clearing the Error Code

This detected error can be cleared with the **[Auto Fault Reset] *A E r*** or manually with the **[Fault Reset Assign] *r 5 F*** parameter after the cause has disappeared.

**[Input Contactor] L C F****Probable Cause**

The drive is not switched on even though **[Mains V. time out] L C E** timeout has elapsed.

**Remedy**

- Verify the input contactor and its wiring.
- Verify the **[Mains V. time out] L C E** timeout.
- Verify the supply mains/contactor/drive wiring.

**Clearing the Error Code**

This detected error can be cleared with the **[Auto Fault Reset] A E r** or manually with the **[Fault Reset Assign] r 5 F** parameter after the cause has disappeared.

## [High Level Error] *L C H F*



### Probable Cause

The maximum level switch is active during filling process.



### Remedy

- Verify the parameter **[Max Level Switch Assign] *L C W L***.
- Verify the state of the corresponding drive digital input and its wiring.



### Clearing the Error Code

This detected error can be cleared with the **[Auto Fault Reset] *R E r*** or manually with the **[Fault Reset Assign] *r 5 F*** parameter after the cause has disappeared.



**[High Level Error] L C L F****Probable Cause**

The minimum level switch is active during emptying process.

**Remedy**

- Verify the parameter **[Min Level Switch Assign] L C W H**.
- Verify the state of the corresponding drive digital input and its wiring.

**Clearing the Error Code**

This detected error can be cleared with the **[Auto Fault Reset] H E r** or manually with the **[Fault Reset Assign] r 5 F** parameter after the cause has disappeared.

## [AI1 4-20mA loss] L F F I



### Probable Cause

Loss of the 4-20 mA on analog input AI1.



### Remedy

Verify the connection on the analog inputs.



### Clearing the Error Code

This detected error can be cleared with the **[Auto Fault Reset] # L r** or manually with the **[Fault Reset Assign] r 5 F** parameter after the cause has disappeared.

**[AI2 4-20mA loss] L F F 2****Probable Cause**

Loss of the 4-20 mA on analog input AI2.

**Remedy**

Verify the connection on the analog inputs.

**Clearing the Error Code**

This detected error can be cleared with the **[Auto Fault Reset] # E r** or manually with the **[Fault Reset Assign] r 5 F** parameter after the cause has disappeared.

## [AI3 4-20mA loss] L F F 3



### Probable Cause

Loss of the 4-20 mA on analog input AI3.



### Remedy

Verify the connection on the analog inputs.



### Clearing the Error Code

This detected error can be cleared with the **[Auto Fault Reset] # L r** or manually with the **[Fault Reset Assign] r 5 F** parameter after the cause has disappeared.

**[AI4 4-20mA loss] L F F 4****Probable Cause**

Loss of the 4-20 mA on analog input AI4.

**Remedy**

Verify the connection on the analog inputs.

**Clearing the Error Code**

This detected error can be cleared with the **[Auto Fault Reset] # E r** or manually with the **[Fault Reset Assign] r 5 F** parameter after the cause has disappeared.

## [AI5 4-20mA loss] L F F 5



### Probable Cause

Loss of the 4-20 mA on analog input AI5.



### Remedy

Verify the connection on the analog inputs.



### Clearing the Error Code

This detected error can be cleared with the **[Auto Fault Reset] # L r** or manually with the **[Fault Reset Assign] r 5 F** parameter after the cause has disappeared.

**[Lead Pump Error]  $\Pi P L F$** **Probable Cause**

The selected lead pump is not available while in run.

**Remedy**

Verify the state of the corresponding drive digital input for the pump availability information (for example **[Pump 1 Ready Assign]  $\Pi P 1$**  for the pump 1).

**Clearing the Error Code**

This detected error can be cleared with the **[Auto Fault Reset]  $\Pi E r$**  or manually with the **[Fault Reset Assign]  $r 5 F$**  parameter after the cause has disappeared.

## [DC Bus Overvoltage] *o b F*



### Probable Cause

- Deceleration time too short or driving load.
- Supply mains voltage too high.



### Remedy

- Increase the deceleration time.
- Configure the **[Dec ramp adapt.]** *b r R* function if it is compatible with the application.
- Verify the supply mains voltage.



### Clearing the Error Code

This detected error can be cleared with the **[Auto Fault Reset]** *R E r* or manually with the **[Fault Reset Assign]** *r 5 F* parameter after the cause has disappeared.





## [Drive Overheating] □ HF



### Probable Cause

Drive temperature too high.



### Remedy

Verify the motor load, the drive ventilation, and the ambient temperature. Wait for the drive to cool down before restarting.



### Clearing the Error Code

This detected error can be cleared with the **[Auto Fault Reset] *r 5 r*** or manually with the **[Fault Reset Assign] *r 5 F*** parameter after the cause has disappeared.

## [Process Overload] $\square L \square$



### Probable Cause

Process overload.



### Remedy

- Verify and remove the cause of the overload.
- Verify the parameters of the **[Process overload]  $\square L d$**  - function.



### Clearing the Error Code

This detected error can be cleared with the **[Auto Fault Reset]  $\# E r$**  or manually with the **[Fault Reset Assign]  $r 5 F$**  parameter after the cause has disappeared.

## [Motor Overload] *o L F*



### Probable Cause

Triggered by excessive motor current.



### Remedy

Verify the setting of the motor thermal monitoring, verify the motor load. Wait for the motor to cool down before restarting.



### Clearing the Error Code

This detected error can be cleared with the **[Auto Fault Reset] *AE r*** or manually with the **[Fault Reset Assign] *r 5 F*** parameter after the cause has disappeared.

## [Single Output Phase Loss] $\square$ P F 1



### Probable Cause

Loss of one phase at drive output.



### Remedy

Verify the wiring from the drive to the motor.



### Clearing the Error Code

This detected error can be cleared with the **[Auto Fault Reset] # E r** or manually with the **[Fault Reset Assign] r 5 F** parameter after the cause has disappeared.

**[Output Phase Loss]  $\square P F 2$** **Probable Cause**

- Motor not connected or motor power too low.
- Output contactor opened.
- Instantaneous instability in the motor current.

**Remedy**

- Verify the wiring from the drive to the motor.
- If an output contactor is being used, set **[OutPhaseLoss Assign]  $\square P L$**  to **[No Error Triggered]  $\square H C$** .
- If the drive is connected to a low-power motor or not connected to a motor: In factory settings mode, motor phase loss detection is active **[Output Phase Loss]  $\square P L = [OPF Error Triggered] 5 E 5$** . Deactivate motor phase loss detection **[Output Phase Loss]  $\square P L = [Function Inactive] n o$** .
- Verify and optimize the following parameters: **[IR compensation]  $\mu F r$** , **[Nom Motor Voltage]  $\mu n 5$**  and **[Rated mot. current]  $n C r$**  and perform **[Autotuning]  $t u n$** .

**Clearing the Error Code**

This detected error can be cleared with the **[Auto Fault Reset]  $R E r$**  or manually with the **[Fault Reset Assign]  $r 5 F$**  parameter after the cause has disappeared.

**[Out Pressure High]  $\square$  P H F****Probable Cause**

The outlet pressure monitoring function has detected a high pressure error.

**Remedy**

- Search for a possible cause of high pressure at the outlet of system.
- Verify the settings of the monitoring function.

**Clearing the Error Code**

This detected error can be cleared with the **[Auto Fault Reset]  $\# E r$**  or manually with the **[Fault Reset Assign]  $r 5 F$**  parameter after the cause has disappeared.

## [Out Pressure Low] $\square$ *PLF*



### Probable Cause

The outlet pressure monitoring function has detected a low pressure error.



### Remedy

- Verify that there is no pipe broken at the outlet of the system.
- Search for a possible cause of low pressure at the outlet of system.
- Verify the settings of the monitoring function.



### Clearing the Error Code

This detected error can be cleared with the **[Auto Fault Reset]** *AFR* or manually with the **[Fault Reset Assign]** *r5F* parameter after the cause has disappeared.



## [Supply Mains Overvoltage] $\square$ 5 F



### Probable Cause

- Supply mains voltage too high.
- Disturbed supply mains.



### Remedy

Verify the supply mains voltage.



### Clearing the Error Code

This detected error can be cleared with the **[Auto Fault Reset]**  $r$  5 F or manually with the **[Fault Reset Assign]**  $r$  5 F parameter after the cause has disappeared.

## [PumpCycle Start Error] *P C P F*



### Probable Cause

The Pumpcycle monitoring function has exceeded the maximum number of start sequences allowed in the time window.



### Remedy

- Search for a possible cause of repetitive start of system.
- Verify the settings of the monitoring function.



### Clearing the Error Code

This detected error can be cleared with the **[Auto Fault Reset] *A F R*** or manually with the **[Fault Reset Assign] *r S F*** parameter after the cause has disappeared.

**[PID Feedback Error] P F Π F****Probable Cause**

The PID feedback error was out of the allowed range around the set point during the time window.

**Remedy**

- Check for mechanical breakdown of pipes.
- Check for water leakage.
- Check for open discharge valve.
- Check for fire hydrant opened.
- Verify the settings of the monitoring function.

**Clearing the Error Code**

This detected error can be cleared with the **[Auto Fault Reset] # E r** or manually with the **[Fault Reset Assign] r 5 F** parameter after the cause has disappeared.

## [Program Loading Error] P G L F



### Probable Cause

Verify that the error code can be cleared.



### Remedy

Contact your local Schneider Electric representative.



### Clearing the Error Code

This detected error is cleared as soon as its cause disappears.

**[Program Running Error] P G r F****Probable Cause**

Verify that the error code can be cleared.

**Remedy**

Contact your local Schneider Electric representative.

**Clearing the Error Code**

This detected error requires a power reset.

## [Input phase loss] PHF



### Probable Cause

- Drive incorrectly supplied or a tripped fused.
- One phase missing.
- 3-phase drive used on a single-phase supply mains.
- Unbalanced load.



### Remedy

- Check the power connection and the fuses.
- Use a 3-phase supply mains.
- Disable the detected error by **[Input phase loss] rPL = [No]** if single phase supply mains is used.



### Clearing the Error Code

This detected error is cleared as soon as its cause disappears.

## [Pump Low Flow Error] *P L F F*



### Probable Cause

The pump low flow monitoring function has detected an error.



### Remedy

- Check valve is closed on discharge.
- Pipes are damaged on the discharge.
- Search for a possible cause of low flow at the outlet of system.
- Verify the settings of the monitoring function.



### Clearing the Error Code

This detected error can be cleared with the **[Auto Fault Reset] *A F R*** or manually with the **[Fault Reset Assign] *r 5 F*** parameter after the cause has disappeared.

## [Safety Function Error] *S R F F*



### Probable Cause

- Debounce time exceeded.
- Internal hardware error.



### Remedy

- Verify the wiring of the digital inputs STOA and STOB.
- Contact your local Schneider Electric representative.



### Clearing the Error Code

This detected error requires a power reset.



**[Motor short circuit] 5CF1****Probable Cause**

Short-circuit or grounding at the drive output.

**Remedy**

- Verify the cables connecting the drive to the motor, and the motor insulation.
- Reduce the switching frequency.
- Connect chokes in series with the motor.
- Verify the adjustment of speed loop and brake.
- Increase the **[Time to restart] t<sub>tr</sub>**
- Increase the switching frequency.

**Clearing the Error Code**

This detected error requires a power reset.

## [Ground Short Circuit] 5 C F 3



### Probable Cause

Significant ground leakage current at the drive output if several motors are connected in parallel.



### Remedy

- Verify the cables connecting the drive to the motor, and the motor insulation.
- Reduce the switching frequency.
- Connect chokes in series with the motor.
- Verify the adjustment of speed loop and brake.
- Increase the **[Time to restart] t<sub>tr</sub>**
- Increase the switching frequency.



### Clearing the Error Code

This detected error requires a power reset.

**[IGBT Short Circuit] 5 C F 4****Probable Cause**

Power component detected error.

**Remedy**

Contact your local Schneider Electric representative.

**Clearing the Error Code**

This detected error can be cleared with the **[Auto Fault Reset] # E r** or manually with the **[Fault Reset Assign] r 5 F** parameter after the cause has disappeared.

## [Motor Short Circuit] 5 L F 5



### Probable Cause

Short-circuit at drive output.



### Remedy

- Verify the cables connecting the drive to the motor, and the motor's insulation.
- Contact your local Schneider Electric representative.



### Clearing the Error Code

This detected error can be cleared with the **[Auto Fault Reset] *r 5 L r*** or manually with the **[Fault Reset Assign] *r 5 F*** parameter after the cause has disappeared.

**[Modbus Com Interruption] 5 L F I****Probable Cause**

Communication interruption on the Modbus port.

**Remedy**

- Verify the communication bus.
- Verify the timeout.
- Refer to the Modbus user manual.

**Clearing the Error Code**

This detected error can be cleared with the **[Auto Fault Reset] *AE r*** or manually with the **[Fault Reset Assign] *r 5 F*** parameter after the cause has disappeared.

## [PC Com Interruption] 5 L F 2



### Probable Cause

Communication interruption with the commissioning software.



### Remedy

- Verify the commissioning software connecting cable.
- Verify the timeout.



### Clearing the Error Code

This detected error can be cleared with the **[Auto Fault Reset] R E r** or manually with the **[Fault Reset Assign] r 5 F** parameter after the cause has disappeared.

**[HMI Com Interruption] 5 L F 3****Probable Cause**

Communication interruption with the Display Terminal.

**Remedy**

- Verify the Display Terminal connection.
- Verify the timeout.

**Clearing the Error Code**

This detected error can be cleared with the **[Auto Fault Reset] R E r** or manually with the **[Fault Reset Assign] r 5 F** parameter after the cause has disappeared.

## [Motor Overspeed] 5 □ F



### Probable Cause

- Instability or driving load too high.
- If a downstream contactor is used, the contacts between the motor and the drive have not been closed before applying a Run command.



### Remedy

- Verify the motor parameter settings.
- Verify the size of the motor/drive/load.
- Verify and close the contacts between the motor and the drive before applying a Run command.



### Clearing the Error Code

This detected error requires a power reset.



## [Motor Stall Error] 5 L F



### Probable Cause

The stall monitoring function has detected an error.



### Remedy

- Search for a mechanical blocking of the motor.
- Search for a possible cause of motor overload.
- Verify the settings of the monitoring function.



### Clearing the Error Code

This detected error can be cleared with the **[Auto Fault Reset] A L r** or manually with the **[Fault Reset Assign] r 5 F** parameter after the cause has disappeared.

## [AI2 Thermal Sensor Error] *E 2 C F*



### Probable Cause

The thermal sensor monitoring function has detected a thermal sensor error on analog input AI2:

- Open circuit, or
- Short circuit.



### Remedy

- Verify the sensor and its wiring.
- Replace the sensor.



### Clearing the Error Code

This detected error can be cleared with the **[Auto Fault Reset] *A E r*** or manually with the **[Fault Reset Assign] *r 5 F*** parameter after the cause has disappeared.

**[AI3 Thermal Sensor Error] E 3 C F****Probable Cause**

The thermal sensor monitoring function has detected a thermal sensor error on analog input AI3:

- Open circuit, or
- Short circuit.

**Remedy**

- Verify the sensor and its wiring.
- Replace the sensor.

**Clearing the Error Code**

This detected error can be cleared with the **[Auto Fault Reset] P E r** or manually with the **[Fault Reset Assign] r 5 F** parameter after the cause has disappeared.

## [AI4 Thermal Sensor Error] *E 4 C F*



### Probable Cause

The thermal sensor monitoring function has detected a thermal sensor error on analog input AI4:

- Open circuit, or
- Short circuit.



### Remedy

- Verify the sensor and its wiring.
- Replace the sensor.



### Clearing the Error Code

This detected error can be cleared with the **[Auto Fault Reset] *R E r*** or manually with the **[Fault Reset Assign] *r 5 F*** parameter after the cause has disappeared.

**[AI5 Thermal Sensor Error] E 5 C F****Probable Cause**

The thermal sensor monitoring function has detected a thermal sensor error on analog input AI5:

- Open circuit, or
- Short circuit.

**Remedy**

- Verify the sensor and its wiring.
- Replace the sensor.

**Clearing the Error Code**

This detected error can be cleared with the **[Auto Fault Reset] P E r** or manually with the **[Fault Reset Assign] r 5 F** parameter after the cause has disappeared.

## [AI2 Th Error Level] *E H 2 F*



### Probable Cause

The thermal sensor monitoring function has detected a high temperature error on analog input AI2.



### Remedy

- Search for a possible cause of overheating.
- Verify the settings of the monitoring function.



### Clearing the Error Code

This detected error can be cleared with the **[Auto Fault Reset] *R E r*** or manually with the **[Fault Reset Assign] *r 5 F*** parameter after the cause has disappeared.

**[AI3 Th Error Level]  $\text{E H } \exists F$** **Probable Cause**

The thermal sensor monitoring function has detected a high temperature error on analog input AI3.

**Remedy**

- Search for a possible cause of overheating.
- Verify the settings of the monitoring function.

**Clearing the Error Code**

This detected error can be cleared with the **[Auto Fault Reset]  $\text{A F R}$**  or manually with the **[Fault Reset Assign]  $\text{r 5 F}$**  parameter after the cause has disappeared.

## [AI4 Th Error Level] *E H 4 F*



### Probable Cause

The thermal sensor monitoring function has detected a high temperature error on analog input AI4.



### Remedy

- Search for a possible cause of overheating.
- Verify the settings of the monitoring function.



### Clearing the Error Code

This detected error can be cleared with the **[Auto Fault Reset] *R E r*** or manually with the **[Fault Reset Assign] *r 5 F*** parameter after the cause has disappeared.



**[AI5 Th Error Level] *E H 5 F*****Probable Cause**

The thermal sensor monitoring function has detected a high temperature error on analog input AI5.

**Remedy**

- Search for a possible cause of overheating.
- Verify the settings of the monitoring function.

**Clearing the Error Code**

This detected error can be cleared with the **[Auto Fault Reset] *R E r*** or manually with the **[Fault Reset Assign] *r 5 F*** parameter after the cause has disappeared.

## [IGBT Overheating] *E J F*



### Probable Cause

Drive power stage overheating.



### Remedy

- Verify the size of the load/motor/drive according to environment conditions.
- Reduce the switching frequency.



### Clearing the Error Code

This detected error can be cleared with the **[Auto Fault Reset] *AE r*** or manually with the **[Fault Reset Assign] *r 5 F*** parameter after the cause has disappeared.

## [Autotuning Error] $t n F$



### Probable Cause

- Special motor or motor whose power is not suitable for the drive.
- Motor not connected to the drive.
- Motor not stopped.



### Remedy

- Verify that the motor/drive are compatible.
- Verify that the motor is connected to the drive during autotuning.
- If an output contactor is being used, verify that it is closed during autotuning.
- Verify that the motor is stopped during autotuning.



### Clearing the Error Code

This detected error can be cleared manually with the **[Fault Reset Assign]  $r 5 F$**  parameter after the cause has disappeared.

## [Process Underload] $\cup L F$



### Probable Cause

Process underload.



### Remedy

- Verify and remove the cause of the underload.
- Verify the parameters of the **[PROCESS UNDERLOAD]**  $\cup L d$  - function



### Clearing the Error Code

This detected error can be cleared with the **[Auto Fault Reset]**  $R E r$  or manually with the **[Fault Reset Assign]**  $r 5 F$  parameter after the cause has disappeared.

## [Supply Mains UnderV] $\cup$ 5 F



### Probable Cause

- supply mains too low.
- Transient voltage dips.



### Remedy

Verify the voltage and the parameters of **[Undervoltage handling]**  $\cup$  5 b.



### Clearing the Error Code

This detected error is cleared as soon as its cause disappears.

## Section 12.3

### FAQ

---

#### FAQ

##### Introduction

If the display does not light up, verify the supply mains to the drive.

The assignment of the fast stop or freewheel functions help to prevent the drive starting if the corresponding digital inputs are not switched on. The drive then displays **[Freewheel] n 5 E** in freewheel stop and **[Fast stop] F 5 E** in fast stop. This is a normal behavior since these functions are active at zero so that the drive is stopped if there is a wire break.

Verify that the run command input is activated in accordance with the selected control mode (**[2/3-wire control] E C C** and **[2-wire type] E C E** parameters).

If the reference channel or command channel is assigned to a fieldbus, when the supply mains is connected, the drive displays **[Freewheel] n 5 E**. It remains in stop mode until the fieldbus gives a command.

##### Option Module Changed or Removed

When an option module is removed or replaced by another, the drive locks in **[Incorrect configuration] C F F** error mode at power-on. If the option module has been deliberately changed or removed, the detected error can be cleared by pressing the **OK** key twice, which causes the factory settings to be restored for the parameter groups affected by the option module.

##### Control Block Changed

When a control block is replaced by a control block configured on a drive with a different rating, the drive locks in **[Incorrect configuration] C F F** fault mode at power-on. If the control block has been deliberately changed, the detected error can be cleared by pressing the **OK** key twice, which **causes all the factory settings to be restored**.



